

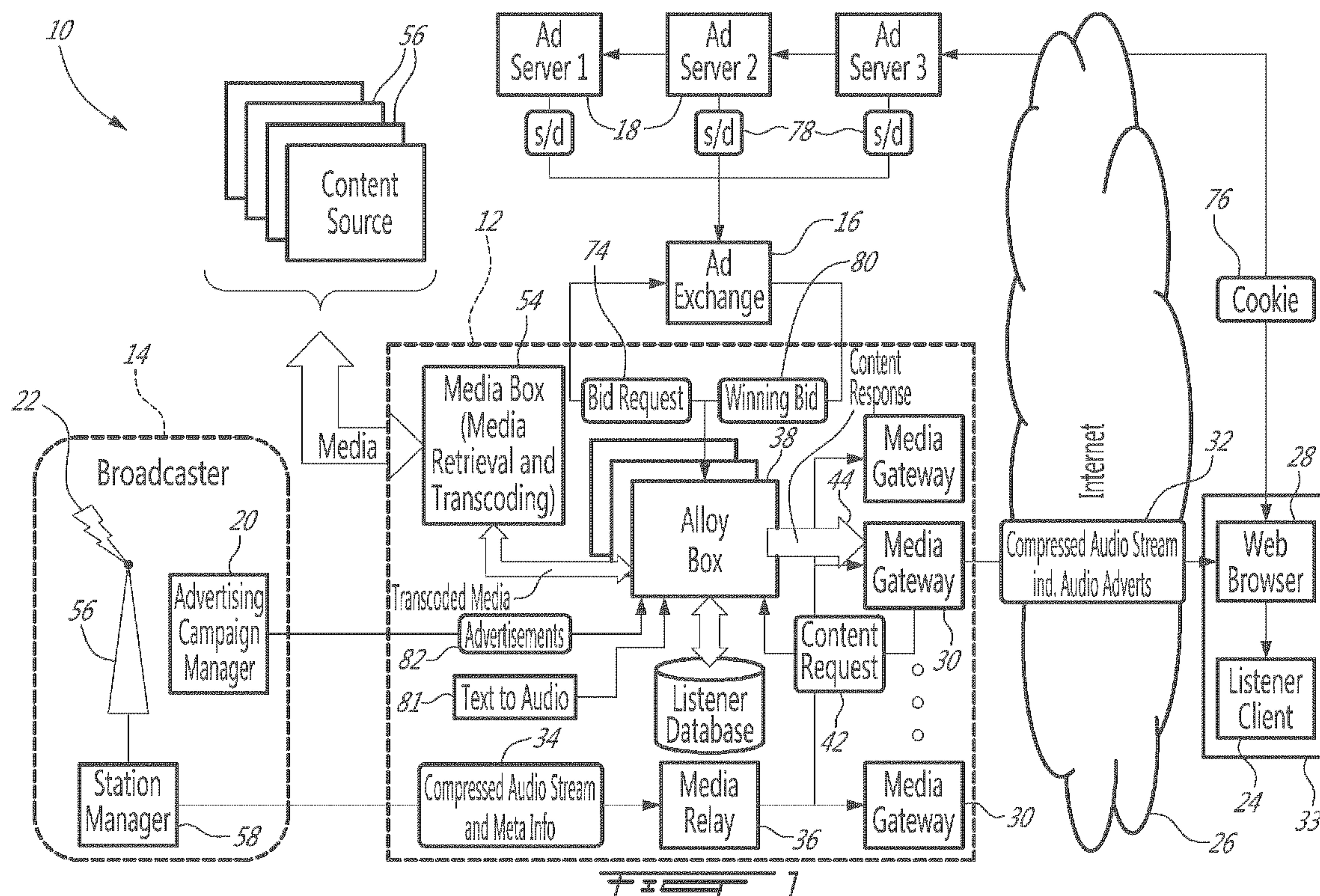

(86) **Date de dépôt PCT/PCT Filing Date:** 2014/01/09
 (87) **Date publication PCT/PCT Publication Date:** 2014/07/17
 (85) **Entrée phase nationale/National Entry:** 2015/07/08
 (86) **N° demande PCT/PCT Application No.:** CA 2014/050010
 (87) **N° publication PCT/PCT Publication No.:** 2014/107807
 (30) **Priorité/Priority:** 2013/01/09 (US61/750,523)

(51) **Cl.Int./Int.Cl. H04H 60/06** (2009.01),
G06Q 30/02 (2012.01), **H04H 60/07** (2009.01),
H04H 60/46 (2009.01), **H04H 60/73** (2009.01),
H04H 60/81 (2009.01), **H04H 60/82** (2009.01)
 (71) **Demandeur/Applicant:**
 ANDO MEDIA LLC, CA
 (72) **Inventeurs/Inventors:**
 GADOURY, JEAN-FRANCOIS, CA;
 ARGUE, JEREMY R., US
 (74) **Agent:** GOUDREAU GAGE DUBUC

(54) **Titre : SYSTEME ET PROCEDE DE PERSONNALISATION D'ANNONCES AUDIO**
 (54) **Title: SYSTEM AND METHOD FOR CUSTOMIZING AUDIO ADVERTISEMENTS**



(57) **Abrégé/Abstract:**

A system and method for streaming customized audio is disclosed. The system and method allow for the selection of advertisements based on at least one feature of a listener and insertion of the selected advertisements into a customized digital audio stream subsequently transmitted to a particular listener. In a particular embodiment, the advertisement is provided as a text string which is converted into audio for insertion into customized digital audio stream.

(12) INTERNATIONAL APPLICATION PUBLISHED UNDER THE PATENT COOPERATION TREATY (PCT)

(19) World Intellectual Property
Organization
International Bureau(10) International Publication Number
WO 2014/107807 A1(43) International Publication Date
17 July 2014 (17.07.2014)

(51) International Patent Classification:

H04H 60/06 (2008.01) H04H 60/73 (2008.01)
G06Q 30/02 (2012.01) H04H 60/81 (2008.01)
H04H 60/07 (2008.01) H04H 60/82 (2008.01)
H04H 60/46 (2008.01)

(21) International Application Number:

PCT/CA2014/050010

(22) International Filing Date:

9 January 2014 (09.01.2014)

(25) Filing Language:

English

(26) Publication Language:

English

(30) Priority Data:

61/750,523 9 January 2013 (09.01.2013) US

(71) Applicant: ANDO MEDIA LLC [CA/CA]; 1440 Ste-Catherine West, Suite 1200, Montréal, Québec H3G 1R8 (CA).

(72) Inventor: GADOURY, Jean-François; 486 Avenue Curzon, St-Lambert, Québec J4P 2V7 (CA).

(74) Agent: GOUDREAU GAGE DUBUC; 2000, McGill College, Suite 2200, Montréal, Québec H3A 3H3 (CA).

(81) Designated States (unless otherwise indicated, for every kind of national protection available): AE, AG, AL, AM, AO, AT, AU, AZ, BA, BB, BG, BH, BN, BR, BW, BY, BZ, CA, CH, CL, CN, CO, CR, CU, CZ, DE, DK, DM, DO, DZ, EC, EE, EG, ES, FI, GB, GD, GE, GH, GM, GT, HN, HR, HU, ID, IL, IN, IR, IS, JP, KE, KG, KN, KP, KR, KZ, LA, LC, LK, LR, LS, LT, LU, LY, MA, MD, ME, MG, MK, MN, MW, MX, MY, MZ, NA, NG, NI, NO, NZ, OM, PA, PE, PG, PH, PL, PT, QA, RO, RS, RU, RW, SA, SC, SD, SE, SG, SK, SL, SM, ST, SV, SY, TH, TJ, TM, TN, TR, TT, TZ, UA, UG, US, UZ, VC, VN, ZA, ZM, ZW.

(84) Designated States (unless otherwise indicated, for every kind of regional protection available): ARIPO (BW, GH, GM, KE, LR, LS, MW, MZ, NA, RW, SD, SL, SZ, TZ, UG, ZM, ZW), Eurasian (AM, AZ, BY, KG, KZ, RU, TJ, TM), European (AL, AT, BE, BG, CH, CY, CZ, DE, DK, EE, ES, FI, FR, GB, GR, HR, HU, IE, IS, IT, LT, LU, LV, MC, MK, MT, NL, NO, PL, PT, RO, RS, SE, SI, SK, SM, TR), OAPI (BF, BJ, CF, CG, CI, CM, GA, GN, GQ, GW, KM, ML, MR, NE, SN, TD, TG).

Published:

— with international search report (Art. 21(3))

(54) Title: SYSTEM AND METHOD FOR CUSTOMIZING AUDIO ADVERTISEMENTS

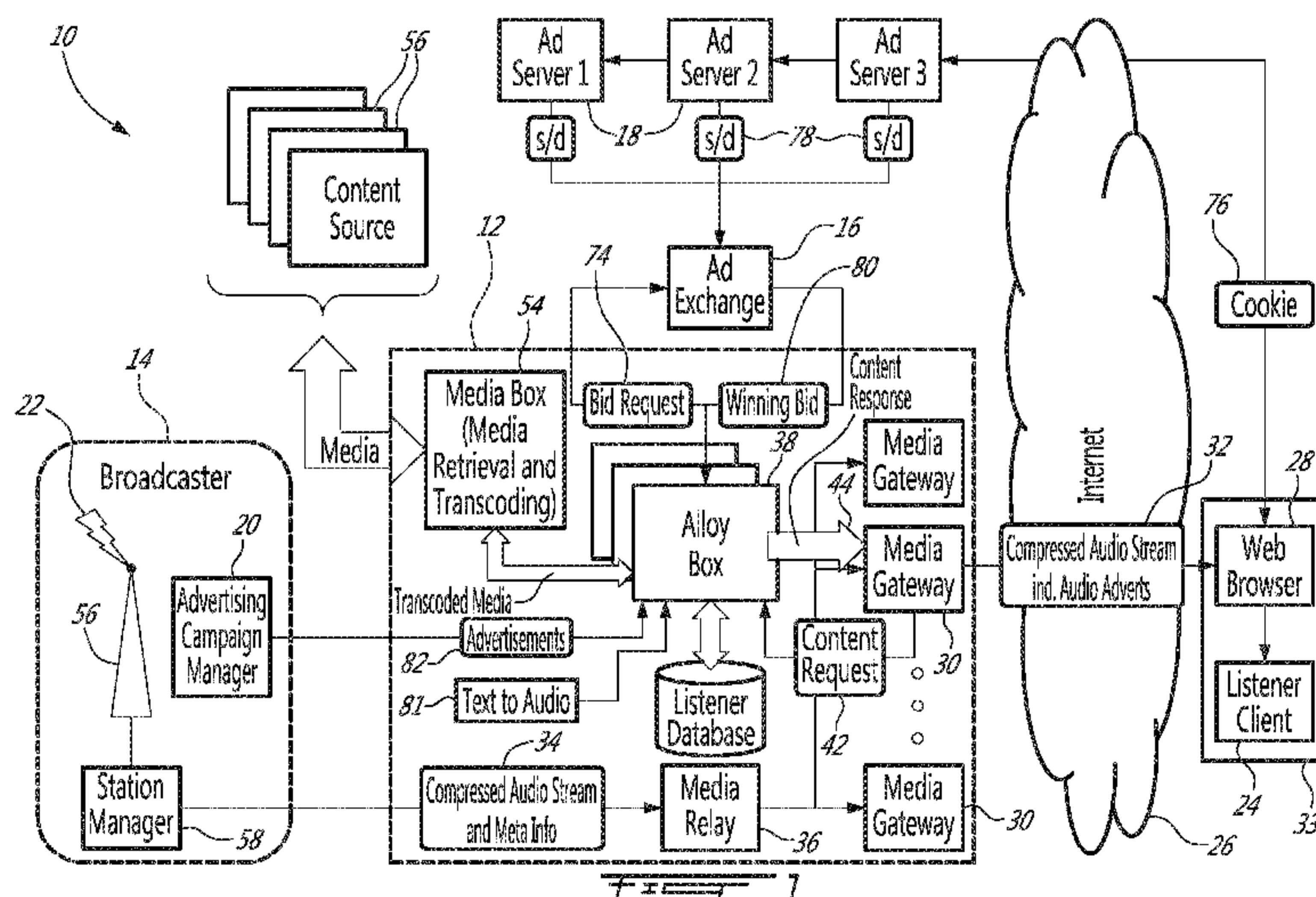

(57) Abstract: A system and method for streaming customized audio is disclosed. The system and method allow for the selection of advertisements based on at least one feature of a listener and insertion of the selected advertisements into a customized digital audio stream subsequently transmitted to a particular listener. In a particular embodiment, the advertisement is provided as a text string which is converted into audio for insertion into customized digital audio stream.

TITLE OF THE INVENTION

SYSTEM AND METHOD FOR CUSTOMIZING AUDIO ADVERTISEMENTS

5 CROSS REFERENCE TO RELATED APPLICATIONS

[0001] This application is claims benefit of U.S. provisional application Serial No. 61/750,523 filed on January 9th, 2013 which is incorporated herein in its entirety by reference.

10

FIELD OF THE INVENTION

[0002] The present invention relates to a system and method for customizing audio advertisements. In particular, the present invention relates to a system and method
15 for customizing and inserting converted-to-audio text advertisements into streaming audio such as an online radio station.

BACKGROUND OF THE INVENTION

20 [0003] The prior art reveals digital online streaming audio systems which allow for the insertion of digitized audio advertising segments into digital broadcast radio streams in order to generate digital broadcast audio streams wherein the selection of advertisements are customized for a particular market or user. One drawback of such prior art systems is that, although the selection of advertisements is customized
25 for a particular market or user, customization of the content of advertisements is not carried out.

[0004] The prior art also reveals systems which collect information on a listener's features, such as their browsing habits, use this information to generate
30 demographic and other information, and then provide this information to potential advertisers such that they can develop marketing campaigns. In particular, the information is used to display particular advertisements to a user during web browsing based on selection of such demographic and other information thereby

improving the chances that the advertisements reach an intended group of users. One drawback of such prior art systems is that advertisements are largely in text format and therefore suitable for display only on web pages.

5 SUMMARY OF THE INVENTION

[0005] In order to address the above and other drawbacks there is provided a system for customizing an audio broadcast and delivering a customized audio stream to a particular listener. The system comprises a listener client associated with
10 the particular listener and comprising an audio stream decoder and an audio player, a broadcast audio stream in a digital format and divided into a plurality of segments therefrom at least one advertising segment, at least one advertisement selected from a source of advertisements based on at least one feature of the listener, a server for receiving the digital broadcast audio stream and the at least one advertisement,
15 wherein the server customizes the digital audio stream by inserting each of the at least one advertisement into a respective one of the at least one advertising segments, the server subsequently streaming the customized digital audio stream to the listener client alone for playing to the particular listener.

20 [0006] There is also disclosed a method of customizing a plurality of broadcast audio streams with advertising from at least one advertiser, each of the streams for streaming to a particular one of a plurality of listener clients, the broadcast audio stream divided into a plurality of segments therefrom at least one advertising segment. The method comprises receiving a digital broadcast audio stream from a
25 broadcaster, receiving an advertising text from the at least one advertiser for each of the listeners, each of the advertising text selected based on at least one feature of the respective listener, generating an audio advertisement from each of the selected advertising text, for each particular listener, inserting the selected audio advertisement into the at least one advertising segment and streaming the
30 customized broadcast audio stream to the particular listener client.

[0007] Also, there is provided a server system for customizing an audio broadcast and delivering a customized audio stream to a plurality of listener clients each

comprising an audio stream decoder and an audio player and associated with a particular one of a plurality of listeners. The system comprises a media relay for receiving a broadcast audio stream in a digital format and divided into a plurality of segments therefrom at least one advertising segment, a plurality of media gateways, each of the media gateways interconnected to a respective one of the listener clients, for each of the particular listeners, at least one audio advertisement selected based on at least one feature of the listener and an associated one of the plurality of media gateways, the associated media gateway customizing the digital broadcast audio stream by inserting the at least one audio advertisement into a respective one of the at least one advertising segments and subsequently streaming the customized digital audio stream to the listener client alone for playing to the particular listener.

[0008] Additionally, there is disclosed a system for customizing an audio broadcast and delivering a customized audio stream to each of a plurality of listeners. The system comprises a broadcast audio stream in a digital format and divided into a plurality of segments therefrom at least one advertising segment, for each listener, a listener client comprising an audio stream decoder and an audio player, for each listener, at least one advertisement selected from a source of advertisements based on at least one feature of the listener, a server for receiving the digital broadcast audio stream and the at least one advertisements, wherein for each particular listener the server customizes the digital audio stream by inserting each of the at least one advertisement into a respective one of the at least one advertising segments, the server subsequently streaming the customized digital audio stream to the listener client for playing to the particular listener.

25

BRIEF DESCRIPTION OF THE DRAWINGS

[0009] In the appended drawings:

30 [0010] Figure 1 is a block diagram of a system for customizing audio advertisements in accordance with an illustrative embodiment of the present invention;

[0011] Figure 2 is detailed block diagram of the server side system of the system of

Figure 1;

[0012] Figure 3 is a block diagram of the alloy box of the system of Figure 1;

5 [0013] Figure 4 is a block diagram of the media gateway of the system of Figure 1;
and

[0014] Figure 5 provides a schematic diagram of a sequence of processing for a
customized audio stream in accordance with an illustrative embodiment of the
10 present invention.

DESCRIPTION OF ILLUSTRATIVE EMBODIMENTS

[0015] Referring to Figure 1, a system for customizing audio advertisements,
15 generally referred to using the reference number 10 and in accordance with an
illustrative embodiment of the present invention, will now be described. As will be
discussed in detail below, the system 10 comprises a server side portion 12 which
interacts with a broadcaster 14 and an ad exchange server 16 in order to provide ad
servers as in 18 as well as a broadcaster's campaign manager 20 with customizable
20 advertising access to broadcast audio streams as in 22 which are destined for
transfer to a listener client as in 24, illustratively via the Internet 26 and the listener's
web browser 28 or smartphone or the like.

[0016] Referring to Figure 2, the server side of the system 12 comprises a plurality of
25 media gateways 30 which provide digital streaming audio as in 32 to the listener
client 24 via the Internet 26. In order to successfully play the streaming audio 32 to
the listener, the listener client 24 typically comprises an audio stream decoder, for
example comprising one or more codecs which are compatible with a format of the
digital streaming audio 32, and an audio player, attached for example to a speaker
30 on the listener's media device 33, such as a tablet, smartphone, netbook, desktop
PC or the like. The streaming audio 32 can comprise any type of conventional radio
broadcast including music, news, sports and the like interspersed with commercial
advertisements and intervals. Of note is that the streaming audio 32 is fully

customizable as the media gateways 30 are able to prepare and transmit streams individually to each of the listeners, including into one of a plurality of different formats compatible with the listener's media device 33. The broadcast audio 34 is received by a media relay 36 which distributes the broadcast audio 34 to respective
5 ones of the media gateways 30 for advertising insert and subsequent streaming to the particular listeners. The media relay 36 may also provide some reformatting of the broadcast audio 34 if required. As will be discussed in more detail below, the broadcast audio 34 typically includes meta data indicating locations within the broadcast audio 34 which are either empty or may be overwritten and therefore can
10 be used for insertion of advertisements and the like.

[0017] Still referring to Figure 2, a plurality of alloy boxes as in 38 are provided which support the media gateways as in 30 in providing customized advertisements for the listeners. When a listener connects to a stream via a media gateway as in 30, the
15 media gateway 30 sends targeting information about the listener ("in band" information) to the alloy box 38. The alloy box 38 then creates or updates the listener's information as a listener profile in the listener database 40. The listener database 40 can comprise a local part and a global part which is used to share listener profiles or portions of listener profiles with other devices, such as alloy
20 boxes, located elsewhere. The listener database 40 is also used to store a content history for each listener, in order to implement frequency caps and optionally impression (i.e. content/advertisement) logging.

[0018] Frequency caps are used to limit the frequency at which a particular content,
25 identified for example using a unique content ID, is played back to the listener, for example limiting a specific advertisement to play back once every hour, or the like. In one embodiment frequency caps are interlocks between schedulable content items and a listener's content history. Different types of frequency caps are foreseen, for example:

30

- Content - prevents duplicate scheduling of the same content item;
- Campaign- prevents content from the same campaign being scheduled too close

together;

- Industry – prevents content from competing advertisers in the same industry being scheduled too close together; and
- Advertiser – prevents content from a single advertiser from being scheduled too close together.

5

[0019] Frequency caps are typically associated with a single specific listener ID. Frequency caps may also include a time stamp indicating a time until which they are valid following which they will be removed from the content history.

10

[0020] The alloy box 38 logs impressions (e.g. playback of an advertisement) in the listener database 40. Impression reports are generated for all advertisements that are played to a particular listener. The impression reports contain the advertisement or content that was played and the time the impression occurred.

15

[0021] Content is requested by the media gateway 30 by illustratively transmitting a content request 42 to the alloy box 38, for example using an HTTP connection or the like. Content, such as an advertisement, is provided by the alloy box 38 to the media gateway 30 in a content response 44 and in the form of a media file which is suitable for injection into the media audio stream 32. Illustratively, the content is identified using a content ID which provides a reference to the media file. In a particular embodiment, a given content ID may reference one of a plurality of different formats of the same media file. Additionally, more than one content ID may reference the same media file.

20

[0022] Referring now to Figure 3, the alloy box 38 comprises a controller 45 and illustratively serves as a caching proxy for all media files which are retrieved with the proper encoding from the media box via the media box client 46 and made available for injection when the retrieval is successful. Other features, such as cache cleanup and expiration are also provided by a media manager 48. The alloy box 38 also comprises an ad scheduler 50 which selects the best advertisements for a given listener, and given a series of rules including:

25

30

- Schedule;
- Target audience;
- Frequency caps
- Excluded items;
- 5 • Optimization by dollar value;
- Etc.

[0023] A listener handler 52 provides listener management for the alloy box 38. This includes:

10

- Fetching listener information;
- Fetching listener content history;
- Updating listener information;
- Updating listener content history (based on impression reports);
- 15 • Listener database maintenance;
- Etc.

20

[0024] This information can be retrieved, for example, as in band information from the listener during login, from a cookie installed on the media device 33 on which the listener client 24 is installed or from listener databases as in 40 located on other similar servers.

25

[0025] Additionally, when a listener disconnects from the media gateway 30 the alloy box 38 is notified.

30

[0026] Referring back to Figure 1, under control of the alloy box 38, a media box 54 retrieves media files from one or more content sources 56 and transcodes the media files to the target stream format. Each alloy box 38 is able to access a media box 54, which comprises a bank of transcoders for retrieving and converting audio clips to one of a plurality different digital audio formats suitable for streaming and dependent on the format which is being used by the media gateway 30 to stream audio to the listener. This format is typically dictated by the capabilities of the listener's audio

client 24. The media box 54 may also include a data store for storing media files.

[0027] Still referring to Figure 1, as discussed above, a media gateway as in 30 which is streaming an audio broadcast to a listener receives a compressed audio stream of the broadcast 34 and illustratively meta data via the media relay 36 from a receiving apparatus such as an antenna 56 and station manager 58. In a particular embodiment the compressed audio stream of the broadcast 34 as well as some or all of the meta data may be received via a broadband network such as the Internet. Using the meta data, the media gateway 30 determines portions of the audio stream suitable for insertion of audio advertisements. A system for carrying out such insertion is described in US Patent Application published with No. 2012/0166289, which is incorporated in its entirety herein by reference.

[0028] Referring now to Figure 4, the media gateway 30 comprises a plurality of queues 60, including a group of global queues 62 and a group of listener specific queues 64. Global queues 62 include sweeper, Public Service Announcement (PSA) and pre-roll queues and listener specific queues 64 include priority spot (or priority advertisement), spot (or normal advertisement) and PSA queues. As known in the art, a sweeper is a promotional item used by the provider of the broadcast (or customized) stream. Typically media from the listener specific queues is used before the global queues as the content of the listener specific queues is generally of greater value. The pre-roll queue is typically used at the commencement of streaming to a listener when the listener specific queues 64 are not yet ready for injection. In this regards, the global queues 62 are typically kept "topped up" to ensure the availability of fall back media. Each of the queues has a configurable low water mark, such that when the media held within the queue drops below this level, new media is acquired, for example by the ad manager 66 and/or media manager 68. The low water mark takes into account rate of consumption as well as latency in receiving new media in order to ensure that an empty queue is never encountered. The media manager 68 also manages a media cache 70 for storing media files whose entries form part of the media queues as in 60.

[0029] Referring back to Figure 2 in addition to Figure 4, in order to populate the

queues as in 60 which are in turn used to populate portions of the audio stream identified as suitable for insertion of audio advertisements, the ad manager 66 requests audio advertisements 44 from its corresponding alloy box 38, illustratively using an HTTP request. The alloy box 38 is also provided with the format in which the advertisement should be provided back to the ad manager 30, for example as it is provided as part of the request 42, such that the advertisement can be readily injected into the audio stream. Additionally, as discussed above, the request 42 includes a coded identifier or other information such that the request can be associated with the listener 24 for which the requested advertisement is destined.

10

[0030] Still referring to Figure 4, selected content such as advertisements, pre-rolls or the like is inserted into predetermined spots within the audio broadcast stream 34 by the stream injector 72, and illustratively in response to meta data transmitted with the broadcast stream 34, to form the streaming audio 32.

15

[0031] Referring back to Figure 1, in an illustrative embodiment, when the alloy box 38 receives a request for an audio advertisement from the media gateway, the alloy box 38 transmits a bid request 74 to the ad exchange server 16. In one embodiment, the ad exchange server 16 enters into a bidding process with the plurality of ad servers as in 18 in order to fulfill the bid request 46. In this regard, the ad servers as in 18 sell “advertising inventory”, i.e, those portions of the audio stream identified as suitable for insertion of audio advertisements, to advertisers in real-time and based on the value the advertisers ascribe to the particular listener. As such, the bid request 46 will typically include information regarding the audio broadcast being listened to and may include in band information collected directly from the listener 24. In band information can be anything sent by the listener’s client application, typically at connection time, such as a unique listener’s ID, device type, IP address, HTTP headers, HTTP query parameters, HTTP cookies or geo-location information (which typically can be derived from the IP address).

20
25
30

[0032] In an alternative embodiment, the ad servers as in 18 are typically aware of certain features of the listener 24 through the use of a cookie 76, or the like which includes a coded identifier such that the listener 24 for which the advertisement is

being bid on can be identified. The cookie 76 will typically provide access to “out of band” information including for example demographic information such as age, civil status, race, profession, sport, hobbies, mother tongue (language), gender and the like and other information either entered by the listener 24 and associated with the cookie, or derived from the listener’s listening and browsing habits. Depending, for example, on the demographic data associated with the listener 24, each ad server as in 18 might provide a bid 78 for fulfilling the bid request 74. The ad exchange 16 illustratively selects the highest (or most valuable) bid as the winning bid 80.

10 [0033] Still referring to Figure 1, the winning bid 80 illustratively includes, and as will be discussed in more detail below could include a text string representation of the advertisement including one or more wild card fields which can be customized using the attributes of the listener 24, such as listener’s name and the like. Some sample text strings are provided following:

15

- Hello \$name\$. I know you were looking for an iPhone, come back to greatdeals dot com and use the displayed code for 5% off.
- Hello \$name\$. If you want a PS3, please visit our web site at greatdeals dot com.
- 20 • Hello \$name\$. If you want a new flat screen TV, please visit our web site at greatdeals dot com.

[0034] In this regard, the alloy boxes as in 38 are able to access a text to audio converter 81 comprising an audio bank which stores a plurality of prerecorded audio clips or segments, illustratively in MP3 format, which can be used to fabricate customized audio advertisements. In this regard, on receiving the text string the alloy box would retrieve one or more audio clips corresponding to the text string and attributes of the listener which are used to fill any wild card fields.

30 [0035] Other aspects of the advertisement may also be customized by the winning bid 80. For example, a particular language, gender, accent (e.g. British, American) or voice (e.g. a prominent person) might be selected by the winning bid 80. These may

also be selected as the listener as an attribute. Using the text string and sound clips from the audio bank of the text to audio converter 81, the alloy box 38 prepares an audio advertisement which fulfills the requirements of the winning bid 80. As necessary the alloy box 38 may transcode the prepared audio advertisement using
5 the media box 54 such that it matches the encoding of the compressed audio stream 32 being streamed to the listener 24.

[0036] Alternatively, the winning bid 80 illustratively includes a link to an audio asset, such as an MP3 audio file stored, for example, in one of the content sources as in 56
10 or elsewhere on the Internet, which can be retrieved by the alloy box 38.

[0037] In still another embodiment, the alloy box 38 might receive advertisements 82 for insertion directly from the broadcaster's advertising campaign manager 20 which can be used to fulfill a request for audio advertisement 42. Again, the campaign
15 manager 20 will typically have access to user information, for example out of band information via a cookie or the like, such that advertisements can be customized to the particular listener.

[0038] The prepared audio advertisement 44 is then provided to the media gateway
20 30 which requested the audio advertisement.

[0039] Referring now to Figure 5 in addition to Figure 1, as discussed above the media relay 36 provides a broadcast audio stream 34 to one or more of the media gateways 30 for transmission to the listener 24. The broadcast audio stream 34
25 illustratively comprises a plurality of different song segments $S_1...S_N$, hosted segments $H_1...H_N$, news segments $N_1...N_N$, advertisements segments, $A_1...A_N$, etc., whose start and end points are typically indicated by meta tags, or markers, as in 84. In this regard, the broadcast audio stream 34 is illustratively in an mpeg audio format or the like and the markers are coded into the mpeg audio stream, for example in
30 appropriate control headers (not shown) or the like, or as meta data. Selected adverts are retrieved from the queues 60 and according to their relative priority and inserted by the stream injector 72 into an indicated spot within the broadcast audio stream 34. The resultant customized audio stream 32 is subsequently transmitted to

the listener's audio client 24.

[0040] Although the present invention has been described hereinabove by way of non-restrictive illustrative embodiments and examples thereof, it should be noted that
5 it will be apparent to persons skilled in the art that modifications may be made to the illustrative embodiments without departing from the spirit and the scope of the present invention.

CLAIMS:

1. A system for customizing an audio broadcast and delivering a customized audio stream to a particular listener, the system comprising:

- 5 a listener client associated with the particular listener and comprising an audio stream decoder and an audio player;
- a broadcast audio stream in a digital format and divided into a plurality of segments therefrom at least one advertising segment;
- 10 at least one advertisement selected from a source of advertisements based on at least one feature of the listener;
- a server for receiving said digital broadcast audio stream and said at least one advertisement and interconnected with said listener client;
- wherein said server customizes said digital audio stream by inserting each of said at least one advertisement into a respective one of said at least one advertising segments, said server subsequently streaming said customized digital audio stream to said listener client alone for playing to the particular listener.
- 15

2. The system of Claim 1, wherein the said broadcast audio stream comprises meta data indicating locations of said advertising segments within the broadcast audio stream.

20

3. The system of Claim 1, wherein the said advertising segments comprise locations within the broadcast audio stream which are empty.

25

4. The system of Claim 1, wherein the said advertising segments comprise locations within the broadcast audio stream which comprise content but may be overwritten.

5. The system of Claim 1, wherein said broadcast audio stream is in a format incompatible with said listener client and further wherein said server converts said broadcast audio stream into a format compatible with said listener client.

30

6. The system of Claim 1, wherein said server comprises a plurality of digital audio stream customizing media gateways and wherein the listener client is interconnected with said server via a dedicated one of said media gateways.

5 7. The system of Claim 6, wherein each of said media gateways comprises a queue for temporarily storing said at least one advertisement, said at least one advertisement removed from said queue on insertion into said respective one of said at least one advertising segments.

10 8. The system of Claim 7, wherein a minimum number of said at least one advertisement are temporarily stored in said queue and further wherein said media gateway retrieves additional ones of said at least one advertisement when said queue reaches said number.

15 9. The system of Claim 7, wherein said queue always stores at least one of said at least one advertisement.

20 10. The system of Claim 7, comprising a plurality of said at least one advertisement, at least one of said advertisements being a priority advertisement and at least one of said advertisements being a normal advertisement, and further comprising at least a high priority queue and a low priority queue, said high priority advertisements stored temporarily in said high priority queue and said low priority advertisements stored temporarily in said low priority queue, and further wherein said low priority advertisements are inserted into said at least one advertising segments only when said high priority queue is empty.

30 11. The system of Claim 7, wherein each of said media gateways comprises at least one global queue, wherein one of said at least one global queue is for storing a pre-roll and further wherein said pre-roll is inserted at a beginning of said digital audio stream when said listener client initially connects to said server.

12. The system of Claim 1, wherein the audio broadcast comprises a conventional radio broadcast comprising one of music, news, sports and combinations

thereof and advertisements and further comprising a station manager for receiving the conventional radio broadcast and converting the conventional radio broadcast into said digital broadcast audio stream.

5 13. The system of Claim 12, wherein said station manager provides meta data indicating positions of said advertisements within said digital broadcast audio stream.

10 14. The system of Claim 1, wherein said source of at least one advertisement is one of a plurality of online advertisers and further comprising an electronic advertisement exchange offering said at least one advertising segment to the plurality of online advertisers, the online advertisers bidding against one another for said at least one advertising segment and based on said at least one feature of the listener, wherein a winning bid of said online advertisers is awarded said at least one advertising segment and provides said at least one advertisement to said server for
15 insertion into said at least one advertising segment.

20 15. The system of Claim 1, wherein a source of the audio broadcast is a broadcaster and said source of at least one advertisement is an advertising campaign manager of the broadcaster, said campaign manager selecting at least one of a plurality of advertisements based on said at least one feature of the listener and providing said at least one selected advertisement to said server for insertion into a respective one of said at least one advertising segment.

25 16. The system of Claim 1, wherein said at least one feature of the listener is selected from a group comprising a unique listener ID, a listener device type, a listener IP address, an HTTP header, an HTTP query parameter, an HTTP cookie, a listener browsing history, geo-location information, an age of the listener, a gender of the listener, a civil status of the listener, a location of the listener, a race of the listener, a profession of the listener, a sport of the listener, a language of the listener, a hobby
30 of the listener and combinations thereof.

17. The system of Claim 1, wherein said at least one feature of the listener is provided to the electronic advertisement exchange using at least one cookie

registered on a media device of the listener and on which said listener client is installed.

18. The system of Claim 14, wherein said at least one feature of the listener is
5 known to said server and further wherein said server provides said at least one feature to said electronic advertisement exchange.

19. The system of Claim 18, wherein said at least one feature of the listener is
known to said listener client and provided to said server by said listener client as in
10 band data.

20. The system of Claim 18, wherein said server further comprises a listener database for storing said at least one feature of the listener.

21. The system of Claim 20, wherein said listener database comprises a local
15 part which is used only by said server and a global part which is used to share at least portions of listener features with other similar servers located elsewhere.

22. The system of Claim 20, wherein said listener database stores a content
20 history for each listener in order to implement frequency caps and/or impression logging.

23. The system of Claim 1, wherein said server further comprises a database for logging advertisements streamed to the listener.

24. The system of Claim 23, wherein said logged advertisements are used to
25 implement frequency caps.

25. The system of Claim 23, wherein each of said advertisements has unique
ID and further wherein said logging comprises collecting a time stamp indicating
30 when said advertisement was inserted into said customized digital audio stream streamed to said listener client.

26. The system of Claim 24, wherein said frequency caps comprises limiting the frequency at which an advertisement is inserted into said customized digital audio stream streamed to said listener.

5 27. The system of Claim 24, wherein said frequency caps comprises limiting an advertisement from a particular advertiser being inserted in said customized digital audio stream streamed to said listener.

10 28. The system of Claim 23, wherein said logged advertisements are used to implement impression logging and generate impression reports.

29. The system of Claim 1, wherein said at least one advertisement comprises a text string and further wherein said server comprises a text to audio convertor for converting said text string into a digital audio clip.

15 30. The system of Claim 29, wherein said text to audio convertor comprises a database comprising a plurality of said digital audio clip prerecorded therein, wherein said server receives said text string from said source of at least one advertisement, retrieves said prerecorded digital audio clip corresponding to said text string and
20 inserts said retrieved prerecorded digital audio clip into said advertising segment.

31. The system of Claim 29, wherein said text string comprises at least one wildcard field and further wherein each of said at least one wildcard field is replaced with an attribute of the listener.

25 32. The system of Claim 31, wherein said wildcard field is a name wildcard and further wherein said attribute of the listener is a name of the listener.

30 33. The system of Claim 30, wherein said retrieved prerecorded audio clip is further selected according to at least one listener preference.

34. The system of Claim 33, wherein said at least one listener preference is one of a particular language, a particular gender, a particular accent, a particular voice and combinations thereof.

5 35. The system of Claim 1, wherein said at least one advertisement comprises a digital audio clip and said server inserts said digital audio clip into said advertising segment.

10 36. The system of Claim 1, wherein prior to said server customizing said digital audio stream, said particular client logs onto said server and sends in band information about the particular listener to the server.

15 37. The system of Claim 36, wherein said server stores said in band information about the particular listener in a listener database.

38. The system of Claim 1, wherein said server comprises a listener handler and a listener database and further wherein said listener handler fetches listener information and updates said listener information in said listener database.

20 39. The system of Claim 38, wherein said listener information is retrieved from said listener client as in band information.

25 40. The system of Claim 38, wherein said listener information is retrieved from a cookie registered on a media device of the listener and on which said listener client is installed.

30 41. The system of Claim 1, further comprising a media box for retrieving additional content files from one or more content sources and comprising a bank of transcoders wherein, if required, said media box transcodes said retrieved content files using one of said transcoders to a format compatible with said customized digital audio stream.

42. The system of Claim 41, wherein said server further comprises a controller which serves as a caching proxy for caching media files retrieved and transcoded by said media box to a format compatible with said customized digital audio stream and makes said retrieved and transcoded media files available to said media gateway.

43. The system of Claim 1, wherein said server further comprises an ad scheduler applying at least one rule for selecting a best one of said at least one advertisement for the listener.

44. The system of Claim 43, wherein said at least one rule comprises one of a predetermined schedule, a target audience, a frequency cap, an excluded item, an optimization by dollar value and combinations thereof.

45. The system of Claim 1, wherein said server and said listener client are interconnected via a broadband connection such as the Internet.

46. A method of customizing a plurality of broadcast audio streams with advertising from at least one advertiser, each of said streams for streaming to a particular one of a plurality of listener clients, each of the plurality of listener clients associated with a particular listener, the broadcast audio stream divided into a plurality of segments therefrom at least one advertising segment, the method comprising:

receiving a digital broadcast audio stream from a broadcaster;

for each particular listener, receiving an advertising text in electronic format from the at least one advertiser for each of the listeners, each of said advertising text selected based on at least one feature of the particular listener;

converting said selected advertising text into an audio advertisement;

for each particular listener, inserting said audio advertisement into the at least one advertising segment and streaming said customized broadcast audio stream to the listener client associated with the particular listener.

47. The method of Claim 46, wherein said digital broadcast audio stream is in a format incompatible with the listener client associated with the particular listener and further wherein said broadcast audio stream is converted into a format compatible with the listener client associated with the particular listener.

5

48. The method of Claim 46, wherein receiving a digital broadcast audio stream comprises receiving a conventional radio broadcast via an antenna and converting the conventional radio broadcast into said digital broadcast audio stream.

10

49. The method of Claim 46, further comprising providing meta data with said broadcast audio stream, said meta data indicating a position of said at least one advertising segment within said digital broadcast audio stream.

15

50. The method of Claim 46, wherein converting said selected advertising text includes converting said selected advertising text according to one of a particular language, a particular gender, a particular accent, a particular voice and combinations thereof selected according to a preference of the respective listener.

20

51. The method of Claim 46, further comprising prerecording a plurality of digital audio clips, each of said clips representing an audio version of said audio advertisements and wherein said converting said selected advertising text comprises retrieving a prerecorded audio clip corresponding to said selected advertising text.

25

52. The method of Claim 51, wherein said prerecording comprises storing said plurality of digital audio clips in a database.

30

53. The method of Claim 46, wherein said advertising text comprises at least one customizable field and further wherein at least one attribute of the particular listener is used to customize said at least one customizable field.

54. The method of Claim 53, wherein said customizable field comprise a name field and said least one attribute of the listener comprises a name of the particular listener.

55. The method of Claim 46, wherein said receiving an advertising text comprises offering the at least one advertising segment to a plurality of advertisers, the advertisers bidding against one another for the advertising segment on an electronic ad exchange and based on at least one feature of the particular listener wherein said electronic ad exchange awards the advertising segment to a winning advertiser, and receiving from the winning advertiser said advertising text.

56. A server system for customizing an audio broadcast and delivering a customized audio stream to a plurality of listener clients each comprising an audio stream decoder and an audio player and associated with a particular one of a plurality of listeners, the server system comprising:

15 a media relay for receiving a broadcast audio stream in a digital format and divided into a plurality of segments therefrom at least one advertising segment;

a plurality of media gateways, one of said media gateways interconnected to each of said listener clients;

20 for each particular listener, at least one audio advertisement selected based on at least one feature of the particular listener and an associated one of said plurality of media gateways, said associated media gateway customizing said digital broadcast audio stream for streaming to the listener client associated with the particular listener by inserting said at least one audio advertisement into a respective one of said at least one advertising segments and subsequently streaming said customized digital audio stream to the associated listener client alone for playing to the particular listener.

57. The server system of Claim 56, wherein the said broadcast audio stream comprises meta data indicating locations of said advertising segments within the broadcast audio stream.

58. The server system of Claim 56, wherein the said advertising segments comprise locations within the broadcast audio stream which are empty.

59. The server system of Claim 56, wherein the said advertising segments comprise locations within the broadcast audio stream which comprise content but may be overwritten.

5

60. The server system of Claim 56, wherein said broadcast audio stream is in a format incompatible with the associated listener client and further wherein said server converts said broadcast audio stream into a format compatible with the associated listener client.

10

61. The server system of Claim 56, wherein each of said media gateways comprises a queue for temporarily storing said at least one advertisement, said at least one advertisement removed from said queue on insertion into said respective one of said at least one advertising segments.

15

62. The server system of Claim 61, wherein a minimum number of said at least one advertisement are temporarily stored in said queue and further wherein said media gateway retrieves additional ones of said at least one advertisement when said queue reaches said number.

20

63. The server system of Claim 61, wherein said queue always stores at least one of said at least one advertisement.

25

64. The server system of Claim 61, comprising a plurality of said at least one advertisement, at least one of said advertisements being a priority advertisement and at least one of said advertisements being a normal advertisement, and further comprising at least a high priority queue and a low priority queue, said high priority advertisements stored temporarily in said high priority queue and said low priority advertisements stored temporarily in said low priority queue, and further wherein said low priority advertisements are inserted into said at least one advertising segments only when said high priority queue is empty.

30

65. The server system of Claim 61, wherein each of said media gateways comprises at least one global queue, wherein one of said at least one global queue is for storing a pre-roll and further wherein said pre-roll is inserted at a beginning of said digital audio stream when the associated listener client initially logs on to the
5 server system.

66. The server system of Claim 56, wherein the audio broadcast comprises a conventional radio broadcast comprising one of music, news, sports and combinations thereof and advertisements and further comprising a station manager for receiving the
10 conventional radio broadcast and converting the conventional radio broadcast into said digital broadcast audio stream.

67. The server system of Claim 66, wherein said station manager provides meta data indicating positions of said advertisements within said digital broadcast audio
15 stream.

68. The server system of Claim 56, wherein said at least one feature of the listener is selected from a group comprising a unique listener ID, a listener device type, a listener IP address, an HTTP header, an HTTP query parameter, an HTTP cookie, a
20 listener browsing history, geo-location information, an age of the listener, a gender of the listener, a civil status of the listener, a location of the listener, a race of the listener, a profession of the listener, a sport of the listener, a language of the listener, a hobby of the listener and combinations thereof.

69. The server system of Claim 56, wherein said at least one feature of the listener is known to each of the plurality of listener clients listener client and provided to said server by the plurality of listener clients as in band data.
25

70. The server system of Claim 56, wherein said server further comprises a
30 listener database for storing said at least one feature of each of the listeners.

71. The server system of Claim 70, wherein said listener database comprises a local part which is used only by said server system and a global part which is used to share at least portions of listener features with other similar servers located elsewhere.

5 72. The server system of Claim 70, wherein said listener database stores a content history for each of the plurality of listeners in order to implement frequency caps and/or impression logging.

10 73. The server system of Claim 56, further comprising a database for logging advertisements streamed to each of the listeners.

74. The server system of Claim 73, wherein said logged advertisements are used to implement frequency caps.

15 75. The server system of Claim 74, wherein each of said advertisements has unique ID and further wherein said logging comprises collecting a time stamp indicating when said advertisement was inserted into said customized digital audio stream streamed to associated listener client.

20 76. The server system of Claim 74, wherein said frequency caps comprises limiting the frequency at which an advertisement is inserted into said customized digital audio stream streamed to the particular listener.

25 77. The server system of Claim 74, wherein said frequency caps comprises limiting an advertisement from a particular advertiser being inserted in said customized digital audio stream streamed to the particular listener.

78. The server system of Claim 73, wherein said logged advertisements are used to implement impression logging and generate impression reports.

30

79. The server system of Claim 56, wherein said at least one advertisement comprises a text string and further and further comprising a text to audio convertor for converting said text string into a digital audio clip.

80. The server system of Claim 79, wherein said text to audio convertor comprises a database comprising a plurality of said digital audio clip prerecorded therein, wherein said text string is received from said source of at least one advertisement, said prerecorded digital audio clip corresponding to said text string is retrieved from said database and said retrieved prerecorded digital audio clip inserted into said advertising segment.

81. The server system of Claim 79, wherein said text string comprises at least one wildcard field and further wherein each of said at least one wildcard field is replaced with an attribute of the particular listener.

82. The server system of Claim 81, wherein said wildcard field is a name wildcard and further wherein said attribute of the listener is a name of the particular listener.

83. The server system of Claim 82, wherein said retrieved prerecorded audio clip is further selected according to at least one preference of the particular listener.

84. The server system of Claim 83, wherein said at least one listener preference is one of a particular language, a particular gender, a particular accent, a particular voice and combinations thereof.

85. The server system of Claim 56, wherein said at least one advertisement comprises a digital audio clip which is inserted into said advertising segment.

86. The server system of Claim 56, wherein prior to customizing said digital audio stream, said respective one of the listener clients logs onto the server system and sends in band information about the particular listener to the server system.

87. The server system of Claim 86, further comprising a listener database and wherein said in band information about each of the plurality of listeners is stored in said listener database.

88. The server system of Claim 56, further comprising a listener handler and a listener database and further wherein said listener handler fetches listener information and updates said listener information in said listener database.

5

89. The server system of Claim 88, wherein said listener information is retrieved from said listener client as in band information.

90. The server system of Claim 88, wherein said listener information is retrieved from a cookie registered on a media device of the listener and on which said listener client is installed.

91. The server system of Claim 56, further comprising a media box for retrieving additional content files from one or more content sources and comprising a bank of transcoders wherein, if required, said media box transcodes said retrieved content files using one of said transcoders to a format compatible with said customized digital audio stream.

92. The server system of Claim 91, further comprising a controller which serves as a caching proxy for caching media files retrieved and transcoded by said media box to a format compatible with said customized digital audio stream and makes said retrieved and transcoded media files available to said associated media gateway.

93. The server system of Claim 56, further comprising an ad scheduler applying at least one rule for selecting a best one of said at least one advertisement for the particular listener.

94. The server system of Claim 93, wherein said at least one rule comprises one of a predetermined schedule, a target audience, a frequency cap, an excluded item, an optimization by dollar value and combinations thereof.

95. The server system of Claim 56, wherein each of said media gateways is interconnected to said respective one of the listener clients via a broadband connection such as the Internet.

5 96. A system for customizing an audio broadcast and delivering a customized audio stream to each of a plurality of listeners, the system comprising:
a broadcast audio stream in a digital format and divided into a plurality of segments therefrom at least one advertising segment;
for each listener, a listener client comprising an audio stream decoder and an
10 audio player;
for each listener, at least one advertisement selected from a source of advertisements based on at least one feature of the listener;
a server for receiving said digital broadcast audio stream and said at least one advertisements;
15 wherein for each particular listener said server customizes said digital audio stream by inserting each of said at least one advertisement into a respective one of said at least one advertising segments, said server subsequently streaming said customized digital audio stream to said listener client for playing to the particular listener.

20

97. The system of Claim 96, wherein each of said listener clients is capable of receiving a digital audio stream in at least one of a plurality of different formats and further wherein said server is capable of converting said digital audio stream into each of said plurality of different formats.

25

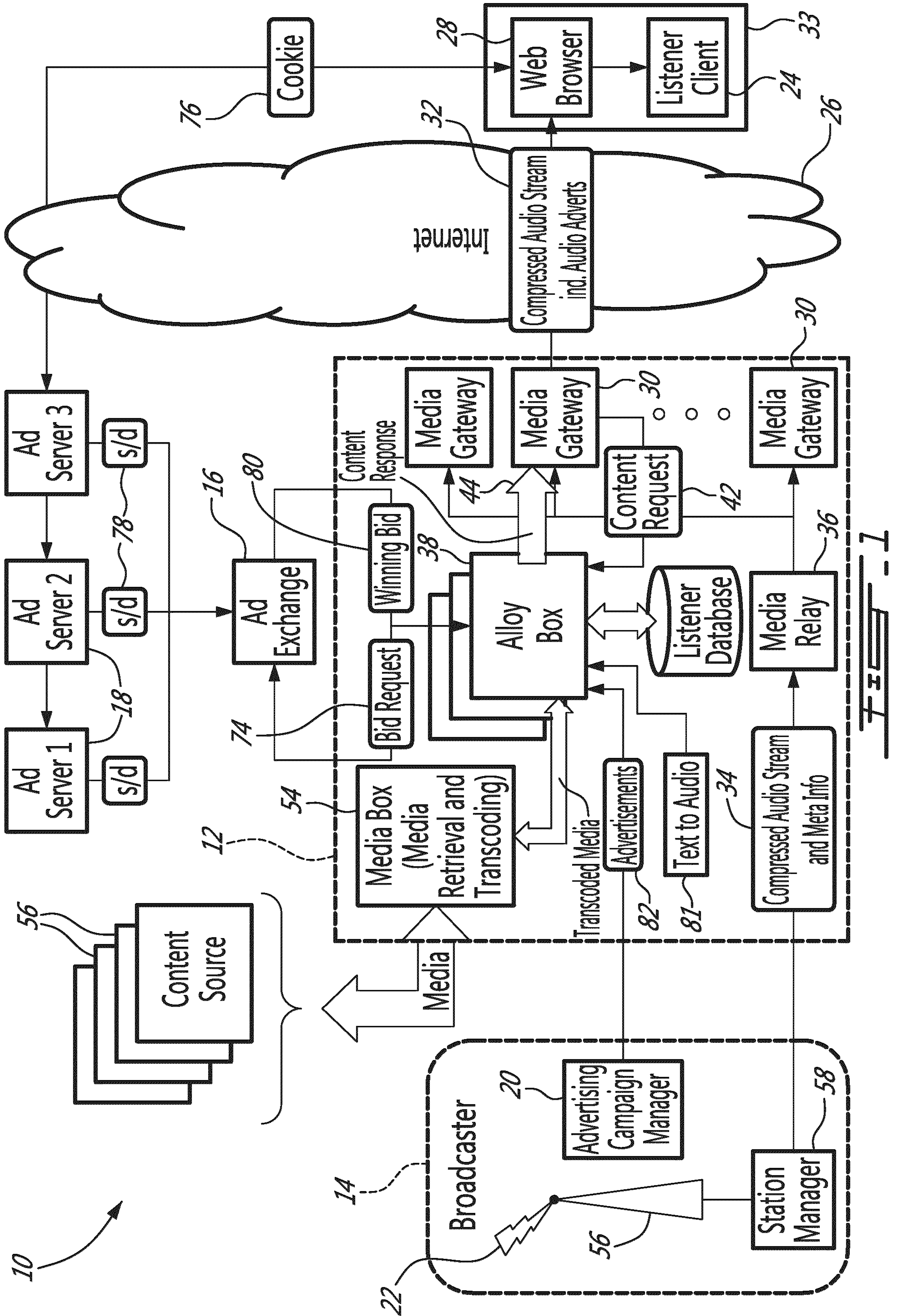

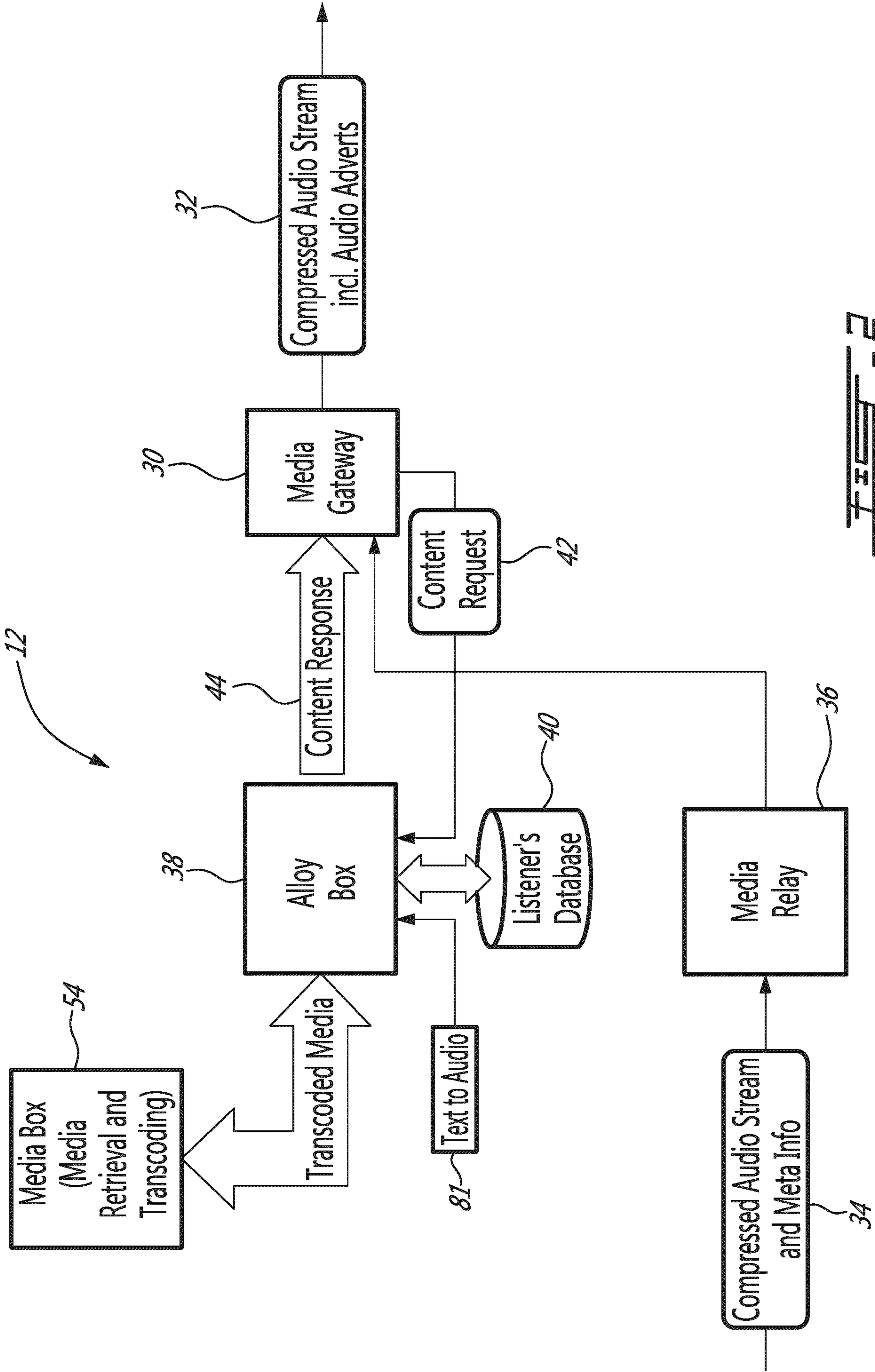

FIG. 2

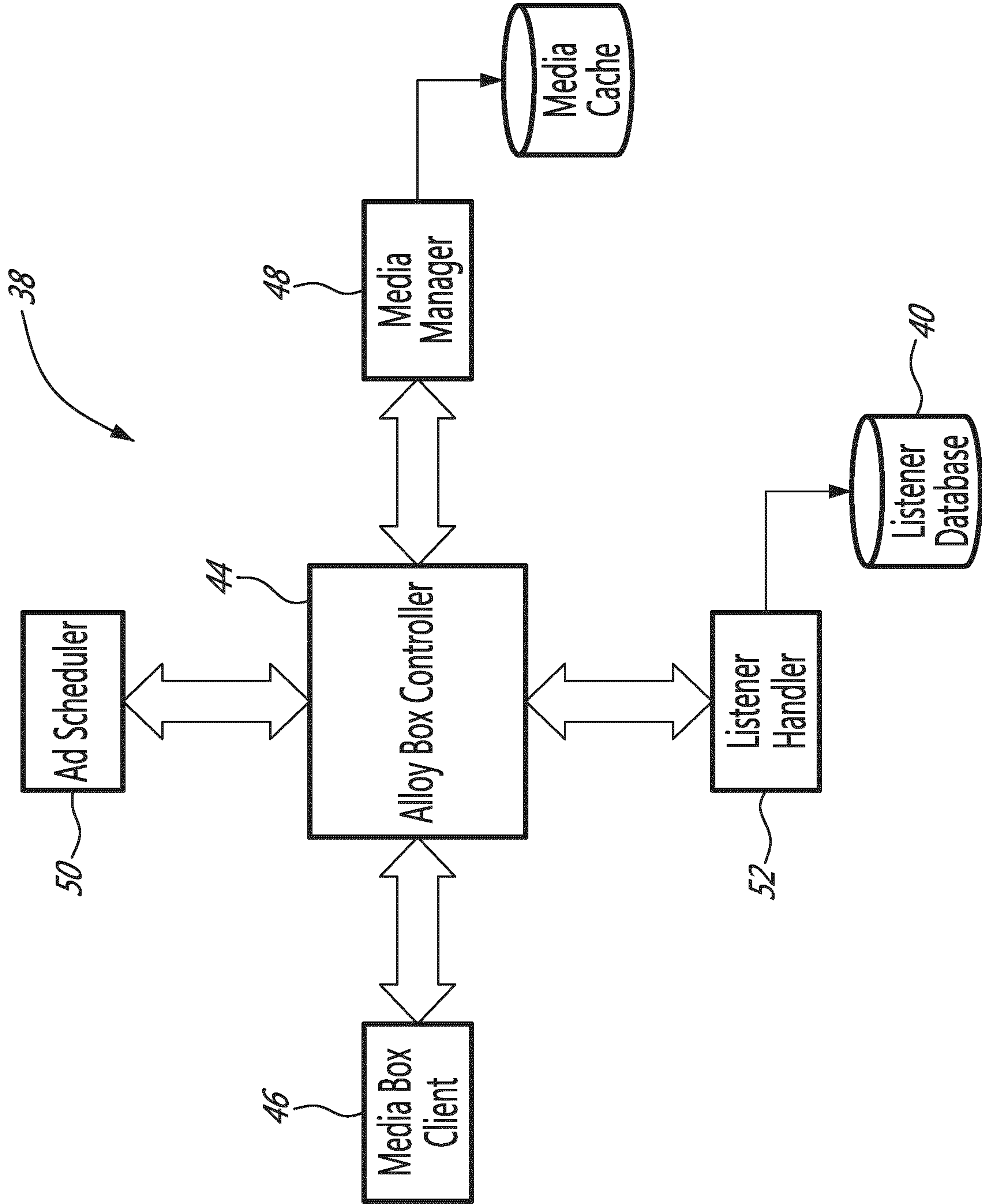

FIG. 3

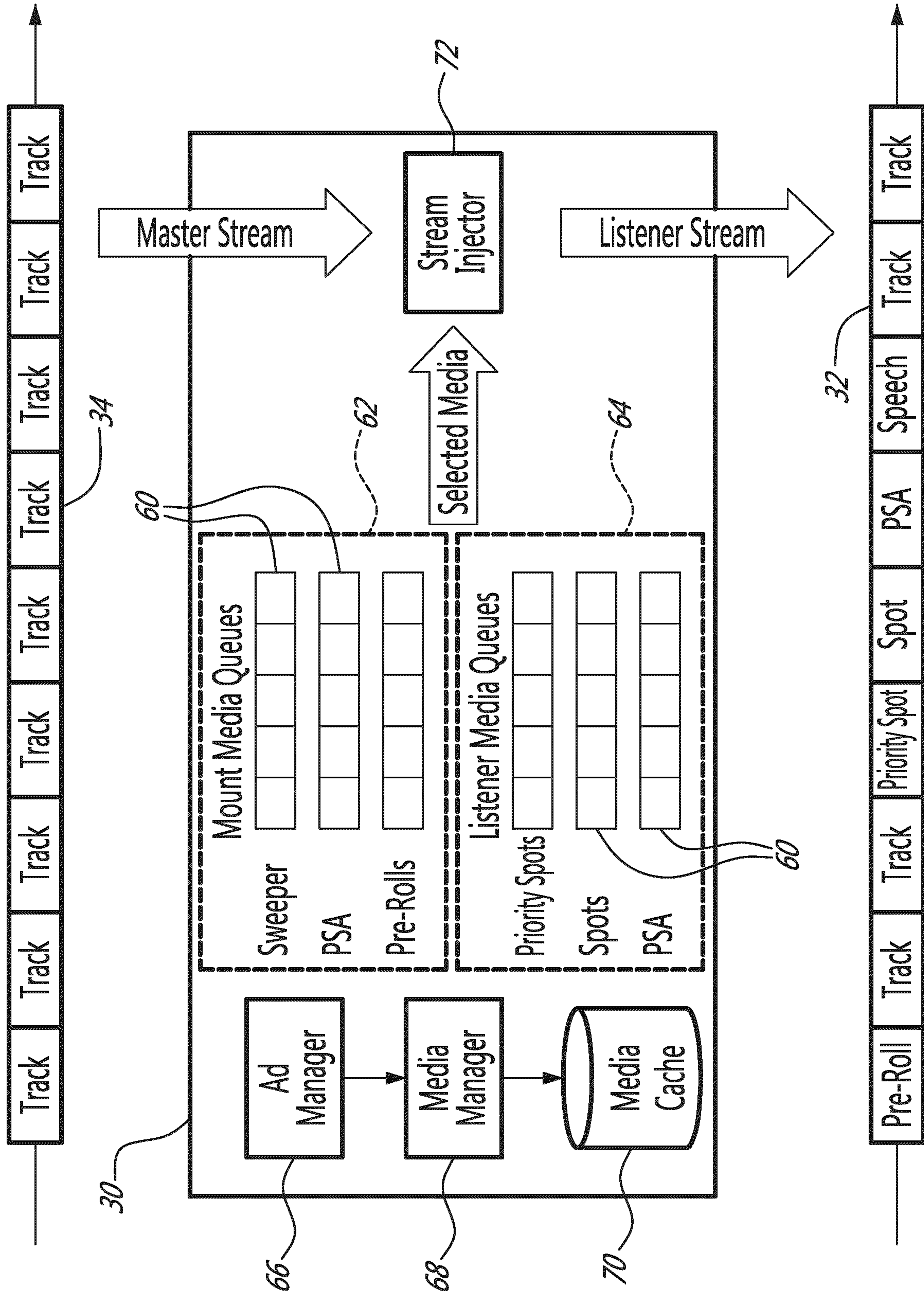
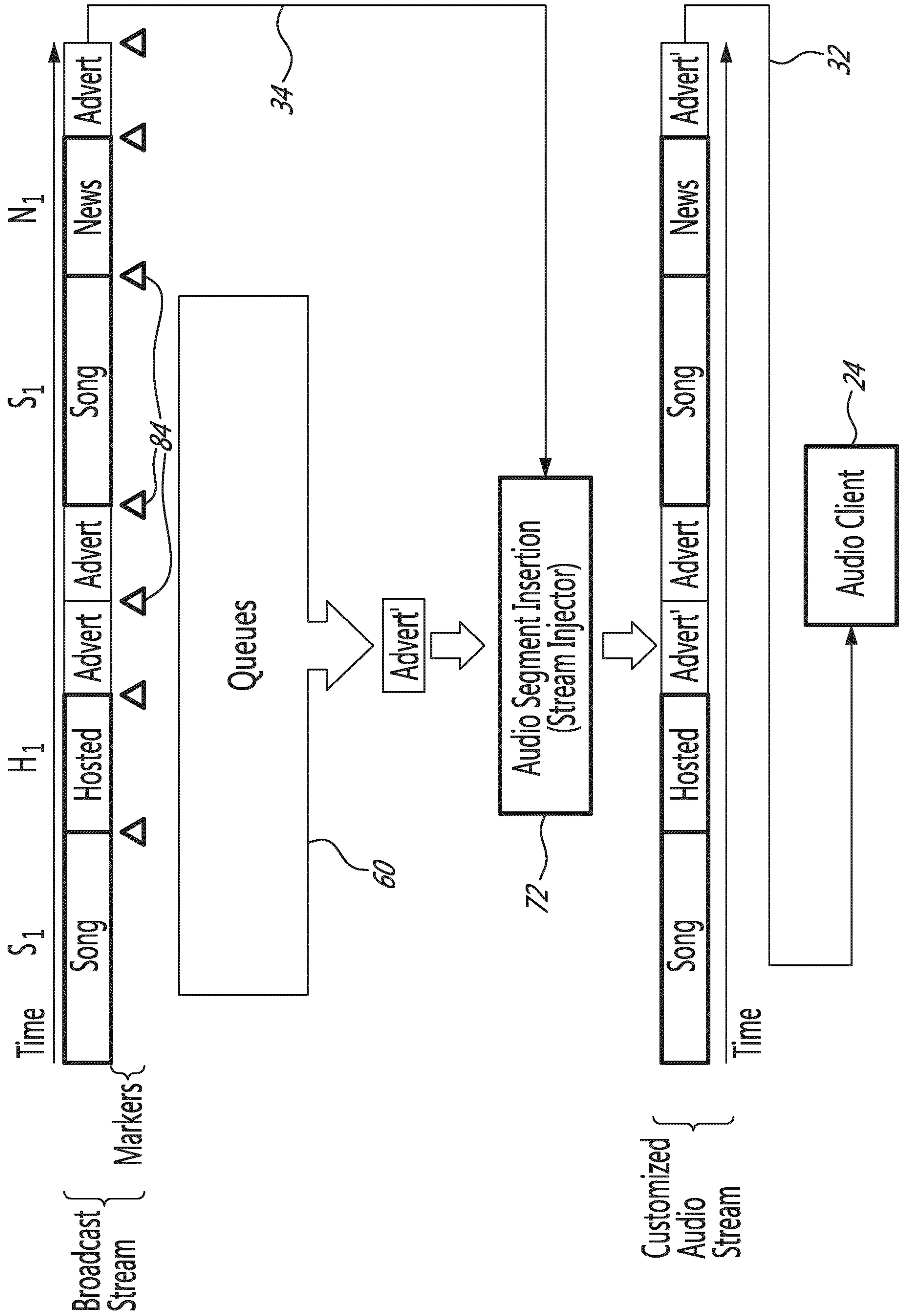

FIG. 4



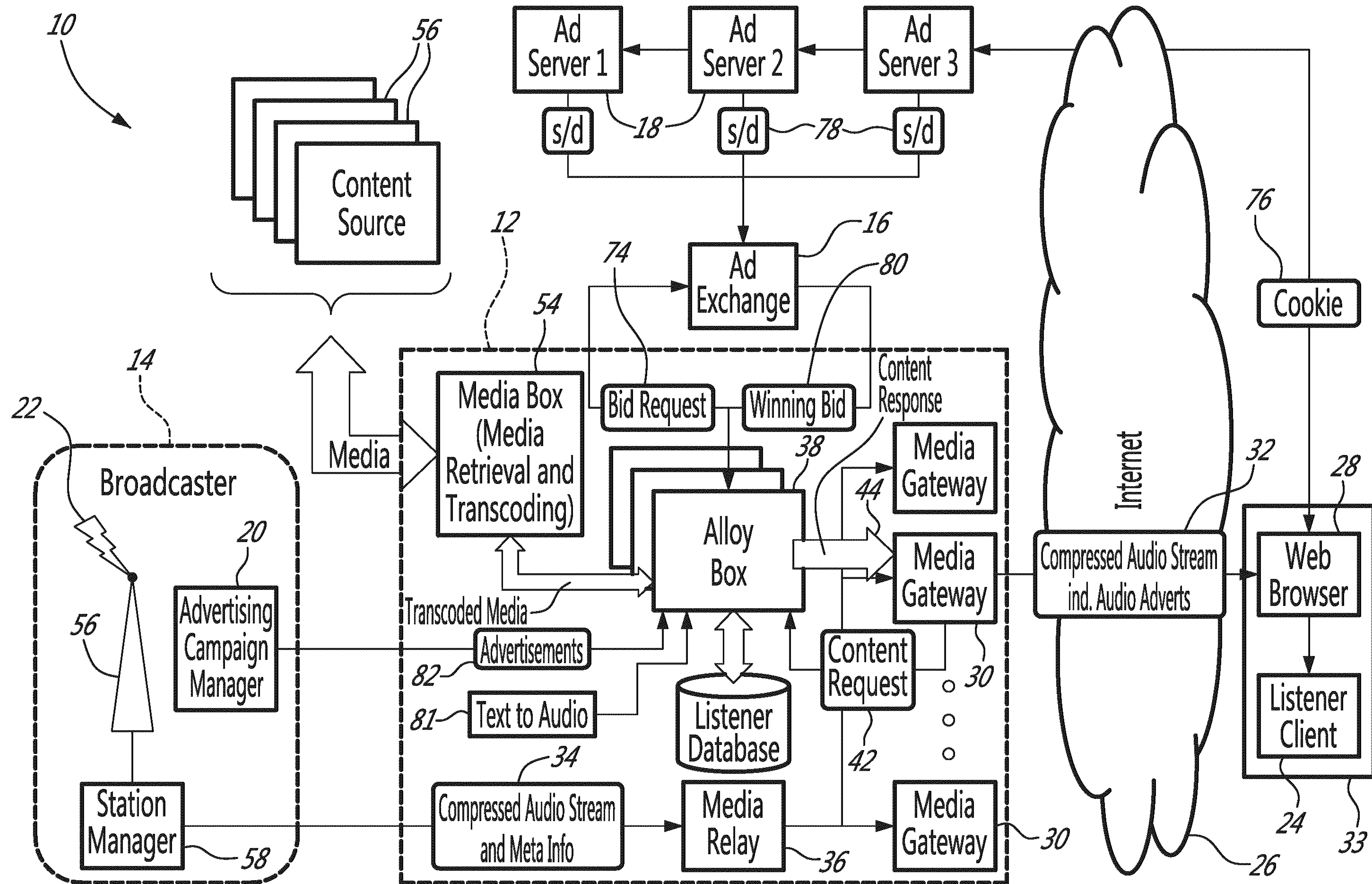

FIG. 1