

104487

2 Sheets Sheet: I.

W. B. Oglesby. Grain Binder.

Fig. 1. PATENTED JUN 21 1870

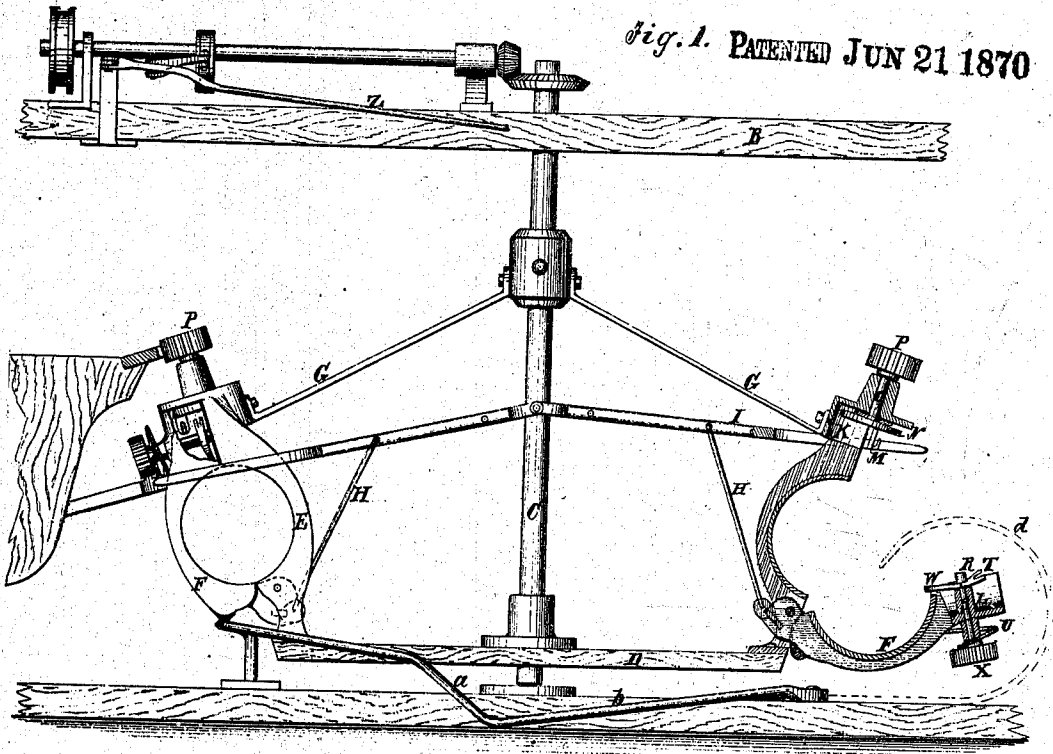
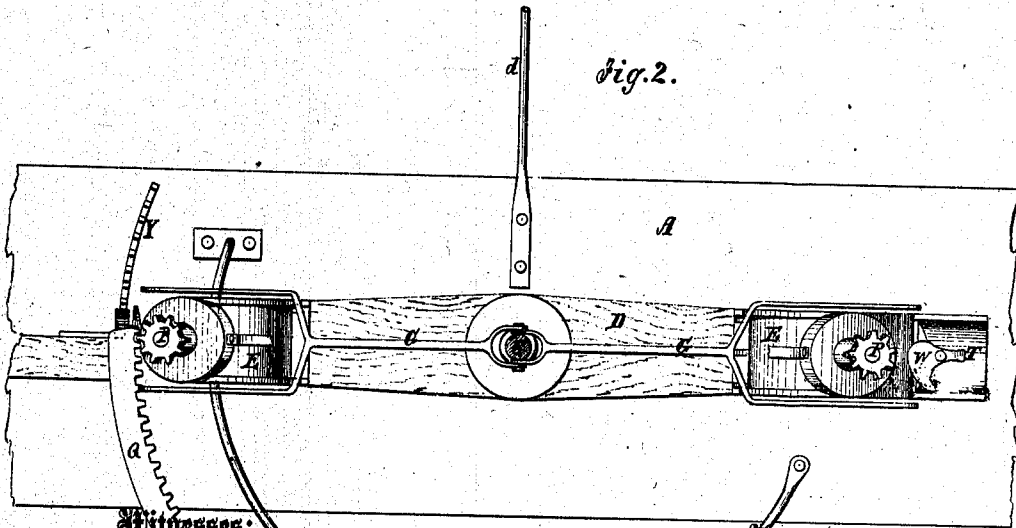

Fig. 2.



Witnesses:

A. Penneker
 S. S. Mabley
 Alex. H. Roberts

Inventor:

W. B. Oglesby

PER *Munn*
 Attorneys

W. B. Oglesby. Grain Binder.

104487

Fig. 3.

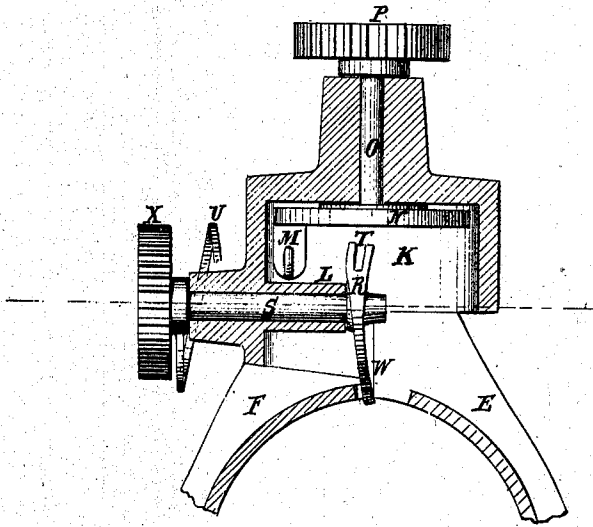
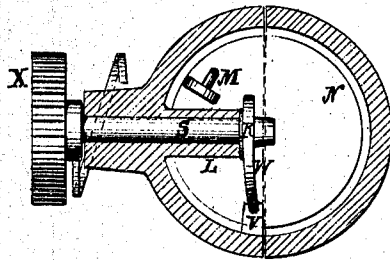

Fig. 4.



Witnesses:

A. Bismeyer
S. S. Mabee
Alex. S. Roberts

Inventor:

W. B. Oglesby

PER

M. M. C.

Attorneys.

UNITED STATES PATENT OFFICE.

WILLIAM B. OGLESBY, OF RIDGE PRAIRIE, ILLINOIS.

IMPROVEMENT IN GRAIN-BINDERS.

Specification forming part of Letters Patent No. 104,487, dated June 21, 1870.

To all whom it may concern:

Be it known that I, WILLIAM B. OGLESBY, of Ridge Prairie, in the county of St. Clair and State of Illinois, have invented new and useful Improvements in Grain-Binders; and I do hereby declare that the following is a full, clear, and exact description thereof, which will enable others skilled in the art to make and use the same, reference being had to the accompanying drawings, forming part of this specification.

This invention relates to improvements in grain-binding attachments to reaping-machines; and consists in one or more pairs of clamps mounted on a horizontally-revolving support, and provided with a twisting device and a tucking device, and arranged to be held open for reception of the gavel by the weight of one of the jaws, which is closed up by a fixed bent rod or cam after reception of the gavel, and the twister and tucker are set in motion by toothed racks gearing with pinions attached to them as they are moved past the said racks, twisting the band of straw previously placed in the clamps by hand, and securing it by tucking the end under, as in hand-binding, after which the hinged jaw falls open and the bundle is ejected by a fixed rod, having one end arranged to stand in the path of the bundle when carried by the open jaws, all as hereinafter more fully specified.

Figure 1 is a side elevation of my improved binder attachment, some parts being sectioned. Fig. 2 is a plan of the same. Fig. 3 is a vertical section through the upper ends of the clamping-jaws, showing the twisting and tucking devices; and Fig. 4 is a horizontal section of the same.

A is a platform, and B a beam above, suitably attached to the reaper-frame, to support the vertical shaft C, on which the plate D, carrying the clamps, twisters, and tuckers, is mounted; also, to support suitable driving mechanism gearing with some moving part of the reaper, and imparting rotary motion to the said shaft. In this example two pairs of clamping-jaws are attached, one of which, E, is permanently connected to the end of the plate D, and to a brace, G, projecting from the shaft; the other, F, is hinged to E near the bottom, and is connected thereat by a brace, H, with a forked compressor-arm, I, jointed

to the shaft C, and projecting at the forked ends past the sides of the jaws to be forced down, when the jaw F is raised up, upon the gavel, and prevent any of the straws being clamped between the meeting parts of the jaws. The upper end of the jaws have semicircular hollow spaces K L, which, when the jaws are closed, constitute a circular space, in which the bands are twisted together and tucked under. The jaw E carries the twister, consisting of a hook, M, projecting downward from the disk N, or it may be an arm on the short spindle O journaled in the top of the jaw E, and provided with a pinion, P, at the upper end, by which it is to be turned when in the course of the revolution around the shaft C it comes in contact with the fixed rack Q. R is a tucker mounted on the spindle S in the cavity L of the jaw F. It has a notched projection, T, which is held in the position represented in the drawings by a spring, U, and a stud, V, and the opposite part consists of a broad flat plate, W, on one side of which is a point bearing against the stop. The spindle of this tucker is arranged in suitable bearings in the top of the jaw, and has at the outer end a pinion, X, for turning it when coming in contact with the rack Y. The bands of straw are made by the attendant and placed in the jaws previous to the reception of the gavel, one end being pressed into the hook M so as to be confined by friction, and the other in the notched end T of the tucker in the same way.

It is designed to place the gavel in the jaws when in the open position, by any suitable raking or other apparatus, which I have not here shown, except as indicated by the vibrating arm Z at the top of the beam B, to which a to-and-fro motion is communicated by the eccentric on the shaft and a rod, the said vibrating arm being such as might be made available for the attachment of a rake to rake the gavels off a platform or apron into the jaws previous to their arrival at the elevation *a* of the rod *b*, by which the swinging jaw F is closed up against the fixed jaw, after which the pinion P comes into gear with the rack Q, and is set in motion, twisting the end of the band held by the hook M around the other end and around the tucker. At the time the pinion P passes beyond the rack Q the pinion M comes into gear with the rack Y, which gives it a half, or

it may be about three-quarters, of a turn, by which both the ends of the band, now twisted together are passed down into the bundle and tucked under the band, where they are left by the return of the tucker after escaping from the rack, the said return movement being caused by the spring M. After the bundle is thus bound the jaws pass beyond the termination of the rod *b*, by which the jaw F is upheld, and it falls down ready for the discharge of the bundle, which is accomplished by the rod *d*, one end of which stands in the path of the bundle, as shown in dotted lines, Fig. 1.

I design to so gear the shaft C that it shall rotate the jaws E F sufficiently slow to allow the person standing on the platform A to securely insert the bands in the tucker and twister.

Having thus described my invention, I claim as new and desire to secure by Letters Patent—

1. The combination of the jaws E F, twister P M, tucker W T X, plate D, cam-rod *a b*, and toothed racks Q Y, when arranged as shown and described.

2. The compressor-arms I, arranged to be operated by the jaws F, as shown and described.

3. The arrangement of the discharger *d*, with reference to the jaws E F and platform A, as and for the purpose specified.

WM. B. OGLESBY.

Witnesses:

THEOPH. HARRISON,
STEPHEN E. OGLESBY.