

F. L. CORTRIGHT & H. HOLMES.
 AUTOMATIC TRAIN STOP.
 APPLICATION FILED NOV. 3, 1916.

1,281,908.

Patented Oct. 15, 1918.
 2 SHEETS—SHEET 1.

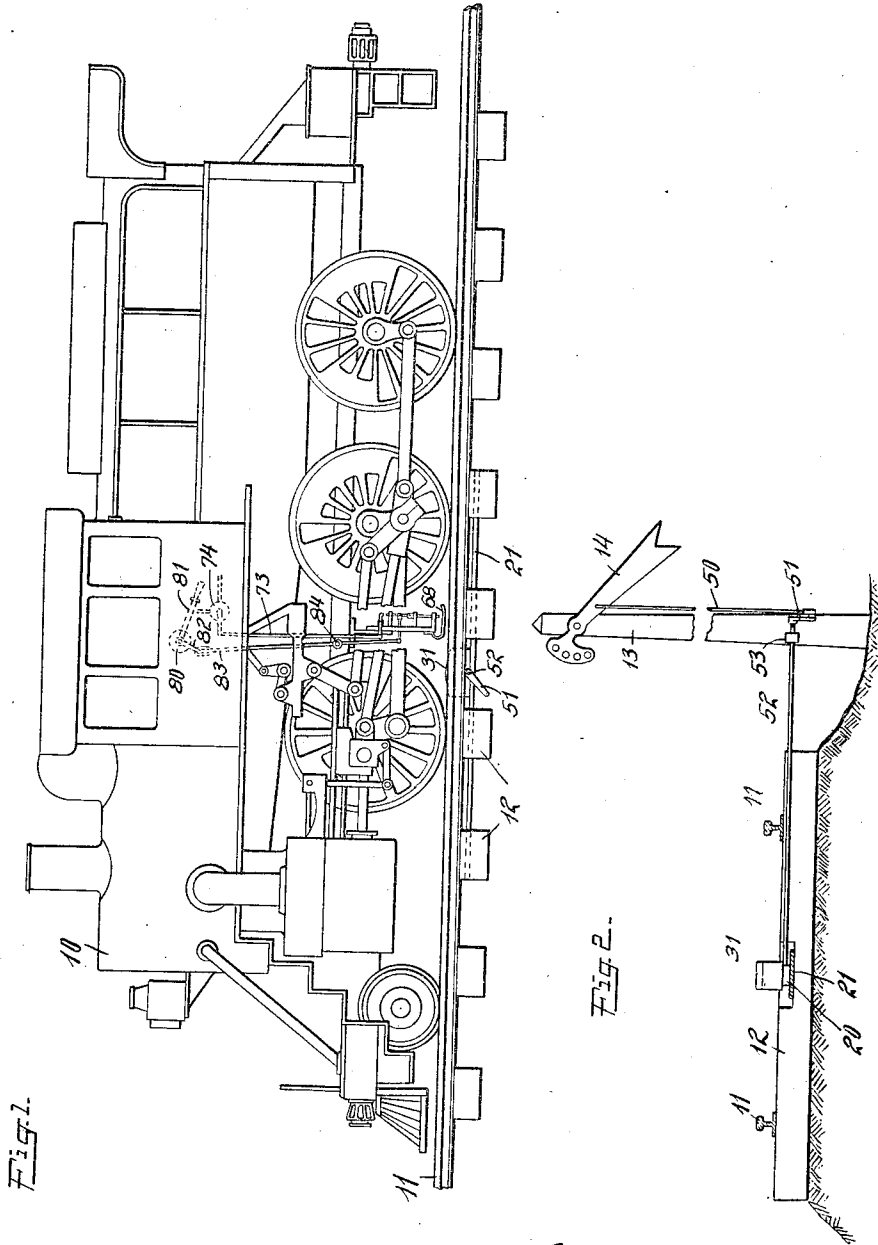

Fred L. Cortright Inventors
and Harold Holmes
 By their Attorney
E. M. Marshall

F. L. CORTRIGHT & H. HOLMES.
 AUTOMATIC TRAIN STOP.
 APPLICATION FILED NOV. 3, 1916.

1,281,908.

Patented Oct. 15, 1918.
 2 SHEETS—SHEET 2.

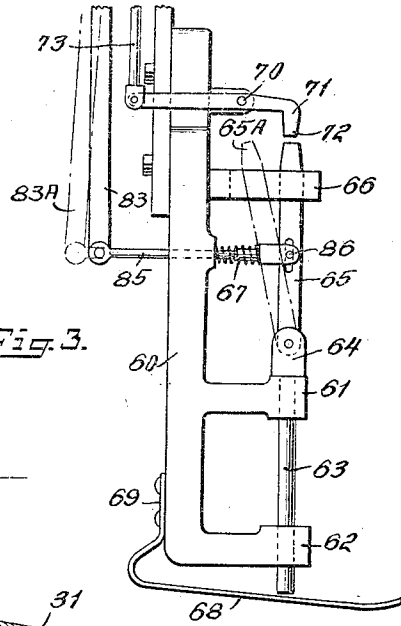

Fig. 3.

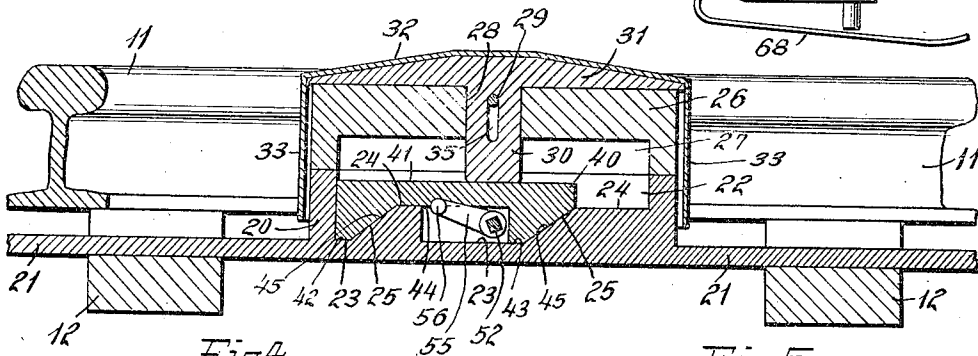

Fig. 4.

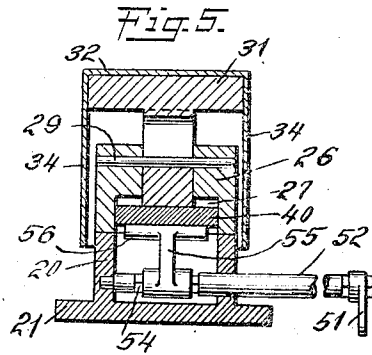
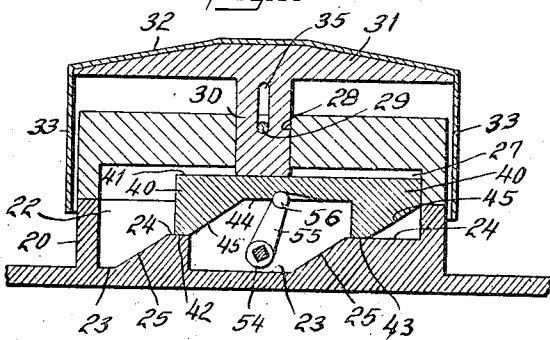

Fig. 5.

Fred L. Cortright Inventors
 and Harold Holmes
 By their Attorney
 E. W. Marshall

UNITED STATES PATENT OFFICE.

FRED L. CORTRIGHT AND HAROLD HOLMES, OF MIDDLETOWN, NEW YORK.

AUTOMATIC TRAIN-STOP.

1,281,908.

Specification of Letters Patent.

Patented Oct. 15, 1918.

Application filed November 3, 1916. Serial No. 129,263.

To all whom it may concern:

Be it known that we, FRED L. CORTRIGHT, a citizen of the United States of America, and a resident of Middletown, Orange county, and State of New York, and HAROLD HOLMES, a citizen of the United States of America, and a resident of Middletown, Orange county, and State of New York, have invented certain new and useful Improvements in Automatic Train-Stops, of which the following is a specification, reference being had to the accompanying drawings, forming a part thereof.

Our invention relates to new and useful improvements in automatic train stops of that type which cause brakes to be applied independently of any act of the driver or motorman if attempt is made to pass a predetermined point at which a stop device has been set to actuate the other parts of the automatic stop mechanism.

The primary object of the invention is to provide a device of this character which is extremely simple in construction.

Another object is to provide a rugged construction capable of readily withstanding any and all strains which may be put upon it.

A further object is to so arrange the apparatus that it will not act except in case of necessity and will perform its function only when the driver or motorman has failed to apply the brakes when he should.

In order that our invention may be thoroughly understood, we will now proceed to describe the same in the following specification, and will then point out the novel features thereof in appended claims.

Referring to the drawings:

Figure 1 is an outline of a steam locomotive with our improvement thereon and on its track.

Fig. 2 is a sectional view of a track and a block signal semaphore and the track device of our apparatus.

Fig. 3 is a side elevation of a preferred form of the train device which forms a part of our invention, together with the track device shown in section and a portion of one of the rails of a track.

Fig. 4 is a side elevation of the track device with the parts thereof shown in a different operative position than that in which they are shown in Fig. 3.

Fig. 5 is a sectional end elevation of the track device with the parts shown in the positions in which they are shown in Fig. 4.

Like characters of reference designate corresponding parts in all the figures.

10 designates a locomotive and 11 the rails of its track on cross ties 12. At one side of the track is shown a block signal post 13 and its pivoted semaphore arm 14.

Between the rails is the track device which comprises a base 20 having an elongated base or flange 21 which is adapted to be secured to the ties 12 by bolts or other suitable means. The base is constructed to form a longitudinal trough-like cavity 22 having two horizontal surfaces 24 between which are inclined surfaces 25. 26 is a cover or casing which fits over this base portion and this is constructed with an inverted longitudinal trough-like cavity 27 which aligns with the cavity 22. A central vertical opening 28, preferably of square cross section, passes through this cover casing.

30 is a post of proper cross-section and size to form a sliding fit in the vertical opening 28. This is an integral part of a cap 31 which fits over the cover casing and extends over it slightly on all sides. This is covered downwardly from all sides of the cap as at 33—34, to form an apron over the cover casing, and the base down to the flange 21 so that it completely covers all the aforesaid parts of the track device except the flange. A slot 35 is formed in the post 30 and a pin 29 affixed to the cover casing and passing through this slot limits the vertical movement of the post and its attached parts.

In the cavity between the base portion and the cover casing is a slidable block 40, the upper surface 41 of which is horizontal, but the under part of which has two lower horizontal surfaces 42—43, an intermediate higher surface 44, and two inclined surfaces 45. This block when at the left hand end of its path of travel, as viewed in Figs. 3 and 4, seats in the lower part of the base with its surfaces 42 and 43 resting upon the surfaces 23—23 as shown in Fig. 3. When it is moved to the right its inclined surfaces 45 ride up the inclines 25 and the block will be raised up into the position in which it is shown in Fig. 4, with its surfaces 42—43 resting solidly upon the surfaces 24 of the base. In doing this the post 30 and its connected parts will be raised and held rigidly in their raised positions, but this vertical movement will not be great enough to raise the lower edge of the apron 33—34 above the parts

which it covers. Thus even when the track device is in its raised position, it is completely protected from rain, snow, sleet and all other extraneous matter.

5 The block 40 is actuated by the following mechanism: A rod 50 is connected with the semaphore arm 14 and to a lever 51 affixed to the end of a shaft 52 which is rotatively supported in a bearing 53. The shaft 52
10 extends into the base 20 and its outer end is supported thereby. It is constructed with a square portion 54 onto which is fitted the hub of an actuator 55 which is a T-shaped lever, the outer end of which is a short bar
15 56 parallel with the shaft 52. This bar fits into a groove in the surface 44 of the slidable block 40. It is obvious that when the semaphore is moved from its safety to danger position, the shaft 52 will be rotated thereby and the slidable block moved to its
20 raised position, thereby raising the cap 31 into position to be engaged by the train device and we shall describe it presently.

The train device, shown somewhat in detail in Fig. 3, comprises a frame 60 which forms bearings 61—62 for a vertically slidable plunger 63, the upper end of which is enlarged as at 64 to limit its downward movement. 65 is a flat arm the lower end
30 of which is pivoted to the head 64 of the plunger, and this arm is guided by a part 66 of frame 60. A compression spring 67 tends to push this arm outward against the guide 66 into a position in alinement with plunger 63. 68 is a shoe of spring metal
35 affixed to the frame 60 at 69 and passing under the lower end of the plunger 63 which projects below the bearing 62. The frame 60 is so placed on the locomotive 10 or other
40 railway car and the parts carried thereby are in such relative positions that they will pass clear of the track device when the latter is not in its raised position as the locomotive or car passes over it, but so that the
45 spring shoe 68 will engage the track device if the latter is in its raised position, and by reason of such engagement will push the plunger 63 and arm 65 upward. This operation will be performed without any shock
50 on the parts regardless of the speed of the locomotive or car.

Pivoted at 70 to the frame 60 is a lever 71, one end of which carries a lip 72 which projects downwardly in line with the upper
55 end of arm 65. The other end of lever 71 is connected by a rod 73 with an auxiliary air brake valve 74. If the parts are in the positions described, the upward movement which will be imparted to the arm 65
60 if the signal is set against the train, will actuate this valve 74 to apply the brakes and stop the train.

If the engineer or motorman performs his duty there is no need of this automatic
65 application of the brakes. For this reason

we have supplied means for cutting off the automatic brake actuating mechanism which work without the engineer or motorman giving any thought to the matter, whenever he applies the brakes in the usual
70 manual manner.

80 is the main air brake valve and 81 the hand lever by means of which it is actuated. Connected with this hand lever is an arm 82
75 which, when the hand lever is raised to apply the brakes, pushes the upper end of a rod 83 which is pivoted at 84, backward and the part thereof below its pivot forward. The lower end of rod 83 is connected with a slide 85 in frame 60, the other end of
80 which is forked and carries a pin 86 which passes through a slot in the arm 65. The forward movement of the lower end of rod 83 into the position indicated by dotted lines at 83^A will move arm 65 into its dotted
85 line position 65^A against the action of spring 67. When in this position any upward movement imparted to it by the train device will have no effect upon the lever 71 or upon the auxiliary air brake valve 74.
90

Thus, it may be seen that if the brakes have been applied at the time the locomotive reaches the track device, the latter will only move the shoe 68 and the plunger 63 with its connected arm 65, without affect-
95 ing the train brakes.

This structure which we have described as illustrative of invention is extremely simple and reliable. We do not however intend to limit ourselves to the specific form
100 or construction described, but intend only such limitations as are imposed by the appended claims.

What we claim is:

1. An automatic train stop comprising a
105 track device having a base having two internal inclined surfaces and a vertically movable cap supported thereby, an apron extending downwardly from the edges of the cap, said apron being of sufficient
110 length to extend over the base when the cap is in its raised position, and a slidable actuating block for the cap having inclined surfaces arranged to ride up on the inclined surfaces of the base when said block
115 is moved in one direction.

2. An automatic train stop comprising a
track device having a base having two internal inclined surfaces and two horizontal surfaces joined to the upper end thereof
120 and a vertically movable cap supported thereby, an apron extending downwardly from the edges of the cap, said apron being of sufficient length to extend over the base when the cap is in its raised position, and
125 a slidable actuating block having two horizontal under surfaces and two inclined surfaces joined thereto, said inclined surfaces of the block being arranged to ride up on the inclined surfaces of the base when said
130

block is moved in one direction and the horizontal under surfaces of the block being arranged to rest on said horizontal surfaces of the base when said block has been thus moved.

3. An automatic train stop comprising a track device having a base having two internal inclined surfaces and a vertical movable cap supported thereby, an apron extending downwardly from the edges of the cap, said apron being of sufficient length to extend over the base when the cap is in its raised position, and a slidable actuating block for the cap having inclined surfaces arranged to ride up on the inclined surfaces of the base when said block is moved in one direction, said cap having a downwardly projecting post arranged to extend to the upper surface of the block.

4. An automatic train stop comprising a track device having a base having two internal inclined surfaces and two horizontal surfaces joined to the upper end thereof and a vertically movable cap supported thereby, an apron extending downwardly from the edges of the cap, said apron being of sufficient length to extend over the base when the cap is in its raised position, and a slidable actuating block having two horizontal under surfaces and two inclined surfaces joined thereto, said inclined surfaces of the block being arranged to ride up on the inclined surfaces of the base when said block is moved in one direction and the horizontal under surfaces of the block being arranged to rest on said horizontal surfaces of the base when said block has been thus moved, said cap having a downwardly projecting post arranged to extend to the upper surface of the block.

5. An automatic train stop comprising a track device having a base having two internal inclined surfaces, a cover casing constructed with a vertical opening and a vertical movable cap supported thereby, an apron extending downwardly from the edges of the cap, said apron being of sufficient length to extend over the base when the cap is in its raised position, and a slidable actuating block for the cap having inclined surfaces arranged to ride up on the inclined surfaces of the base when said block is moved in one direction, said cap having a downwardly projecting post arranged to extend through the cover casing opening.

6. An automatic train stop comprising a track device having a base having two internal inclined surfaces, a cover casing having a central vertical opening of polygonal cross-section, and two horizontal surfaces joined to the upper end thereof and a ver-

tically movable cap supported thereby, an apron extending downwardly from the edges of the cap, said apron being of sufficient length to extend over the base when the cap is in its raised position, and a slidable actuating block having two horizontal under surfaces and two inclined surfaces joined thereto, said inclined surfaces of the block being arranged to ride up on the inclined surfaces of the base when said block is moved in one direction and the horizontal under surfaces of the block being arranged to rest on said horizontal surfaces of the base when said block has been thus moved, said cap having a downwardly projecting post of similar cross-section to that of the cover casing opening arranged to extend through said cover casing opening to the upper surface of the block.

7. An automatic train stop comprising a track device having a base having two internal inclined surfaces and a vertically movable cap supported thereby, an apron extending downwardly from the edges of the cap, said apron being of sufficient length to extend over the base when the cap is in its raised position, a slidable actuating block for the cap having inclined surfaces arranged to ride up on the inclined surfaces of the base when said block is moved in one direction, a shaft rotatively mounted in the base and a lever attached to the shaft and arranged to move the block when said shaft is rotated.

8. An automatic train stop comprising a track device having a base having two internal inclined surfaces and two horizontal surfaces joined to the upper end thereof and a vertically movable cap supported thereby, an apron extending downwardly from the edges of the cap, said apron being of sufficient length to extend over the base when the cap is in its raised position, a slidable actuating block having two horizontal under surfaces and two inclined surfaces joined thereto, said inclined surfaces of the block being arranged to ride up on the inclined surfaces of the base when said block is moved in one direction and the horizontal under surfaces of the block being arranged to rest on said horizontal surfaces of the base when said block has been thus moved, a shaft rotatively mounted in the base and a lever attached to the shaft and having a T-shaped head adapted to fit in a transverse groove in the under side of the block and to move said block when said shaft is rotated.

In witness whereof we have hereunto set our hands this 11th day of October, 1916.

FRED L. CORTRIGHT.
HAROLD HOLMES.