

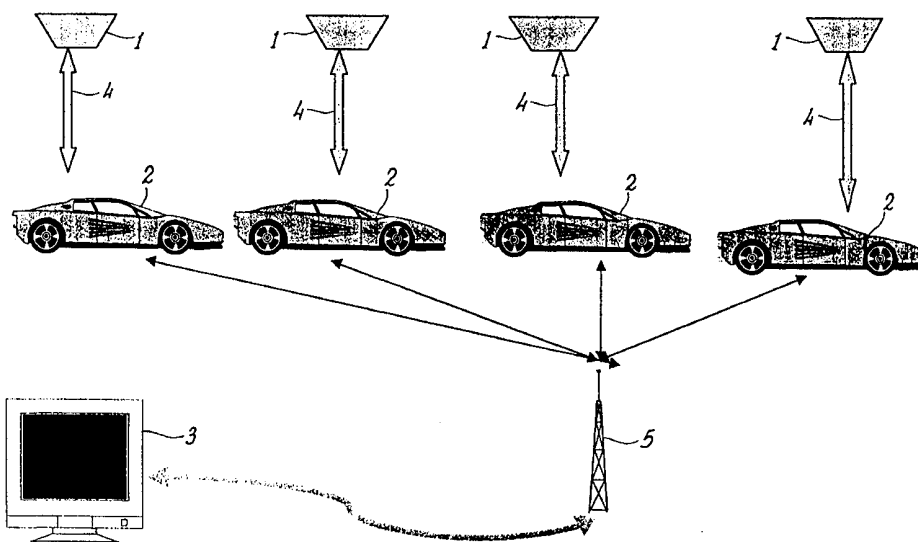

INTERNATIONAL APPLICATION PUBLISHED UNDER THE PATENT COOPERATION TREATY (PCT)

<p>(51) International Patent Classification ⁷ : G07B 15/00</p>	<p>A1</p>	<p>(11) International Publication Number: WO 00/45343 (43) International Publication Date: 3 August 2000 (03.08.00)</p>
<p>(21) International Application Number: PCT/IT00/00024 (22) International Filing Date: 25 January 2000 (25.01.00) (30) Priority Data: RM99A000061 27 January 1999 (27.01.99) IT (71)(72) Applicant and Inventor: FEDERICI, Marcello [IT/IT]; Via A. da Rothweill, 2, I-67100 L'Aquila (IT). (74) Agents: BANCHETTI, Marina et al.; Ing. Barzanò & Zanardo Roma S.p.A., Via Piemonte, 26, I-00187 Roma (IT).</p>		<p>(81) Designated States: AE, AL, AM, AT, AU, AZ, BA, BB, BG, BR, BY, CA, CH, CN, CR, CU, CZ, DE, DK, DM, EE, ES, FI, GB, GD, GE, GH, GM, HR, HU, ID, IL, IN, IS, JP, KE, KG, KP, KR, KZ, LC, LK, LR, LS, LT, LU, LV, MA, MD, MG, MK, MN, MW, MX, NO, NZ, PL, PT, RO, RU, SD, SE, SG, SI, SK, SL, TJ, TM, TR, TT, TZ, UA, UG, US, UZ, VN, YU, ZA, ZW, ARIPO patent (GH, GM, KE, LS, MW, SD, SL, SZ, TZ, UG, ZW), Eurasian patent (AM, AZ, BY, KG, KZ, MD, RU, TJ, TM), European patent (AT, BE, CH, CY, DE, DK, ES, FI, FR, GB, GR, IE, IT, LU, MC, NL, PT, SE), OAPI patent (BF, BJ, CF, CG, CI, CM, GA, GN, GW, ML, MR, NE, SN, TD, TG).</p> <p>Published <i>With international search report.</i> <i>In English translation (filed in Italian).</i></p>

(54) Title: AUTOMATIC CHARGING SYSTEM FOR VEHICLES



(57) Abstract

An automatic debiting system for transport means comprising a plurality of ground stationary stations (1), mobile apparatuses installed on board of the transportation means (2) and a central data processing apparatus (3), characterized in that each stationary station (1) includes a radio transmitter (8), which sends a signal on a channel (4) that can be received by the mobile apparatuses, in that said mobile apparatuses include a processing unit (14, 16, 17, 18, 23, 24, 25, 26) connected to a radio receiver (19) tuned on said channel (4), to a memory device (15) and to a telecommunications device (20, 21, 22) for carrying out communications with the data processing central apparatus (3), said processing central apparatus (3) being provided with a telecommunication apparatus (5).

FOR THE PURPOSES OF INFORMATION ONLY

Codes used to identify States party to the PCT on the front pages of pamphlets publishing international applications under the PCT.

AL	Albania	ES	Spain	LS	Lesotho	SI	Slovenia
AM	Armenia	FI	Finland	LT	Lithuania	SK	Slovakia
AT	Austria	FR	France	LU	Luxembourg	SN	Senegal
AU	Australia	GA	Gabon	LV	Latvia	SZ	Swaziland
AZ	Azerbaijan	GB	United Kingdom	MC	Monaco	TD	Chad
BA	Bosnia and Herzegovina	GE	Georgia	MD	Republic of Moldova	TG	Togo
BB	Barbados	GH	Ghana	MG	Madagascar	TJ	Tajikistan
BE	Belgium	GN	Guinea	MK	The former Yugoslav Republic of Macedonia	TM	Turkmenistan
BF	Burkina Faso	GR	Greece	ML	Mali	TR	Turkey
BG	Bulgaria	HU	Hungary	MN	Mongolia	TT	Trinidad and Tobago
BJ	Benin	IE	Ireland	MR	Mauritania	UA	Ukraine
BR	Brazil	IL	Israel	MW	Malawi	UG	Uganda
BY	Belarus	IS	Iceland	MX	Mexico	US	United States of America
CA	Canada	IT	Italy	NE	Niger	UZ	Uzbekistan
CF	Central African Republic	JP	Japan	NL	Netherlands	VN	Viet Nam
CG	Congo	KE	Kenya	NO	Norway	YU	Yugoslavia
CH	Switzerland	KG	Kyrgyzstan	NZ	New Zealand	ZW	Zimbabwe
CI	Côte d'Ivoire	KP	Democratic People's Republic of Korea	PL	Poland		
CM	Cameroon	KR	Republic of Korea	PT	Portugal		
CN	China	KZ	Kazakstan	RO	Romania		
CU	Cuba	LC	Saint Lucia	RU	Russian Federation		
CZ	Czech Republic	LI	Liechtenstein	SD	Sudan		
DE	Germany	LK	Sri Lanka	SE	Sweden		
DK	Denmark	LR	Liberia	SG	Singapore		
EE	Estonia						

AUTOMATIC CHARGING SYSTEM FOR VEHICLES

5 This invention relates to an automatic charging system for public transport means.

 More particularly, this invention relates to a system of the above said kind for monitoring in simple, reliable and inexpensive way the road traffic and for charging or debiting in dynamic and customized way the
10 costs connected with toll services, such as high way tolls and toll parking places as well as fines connected with some infractions.

 It is known that the number of road vehicles is extremely high and that, particularly in most industrialized countries, the roadway network is capillary distributed all over the territory. This development entailed an
15 increase in the number of available toll services, such as toll highways, urban areas the access to or the permanence in which is connected with payment of a toll determined on a time or transit base, hourly toll parking places. In view of the above, an increasing necessity has arisen to reduce and speed-up the actions that the vehicle drivers have to perform for
20 effecting the payments, thereby facilitating the utilization of such services.

 In recent year, some telematic approaches have been developed in respect of payment of highway tolls, in the frame of the so-called Intelligent Transportation System (or ITS). Such approaches include the Automatic Debiting System (ADS) or the more advanced Automatic
25 Dynamic Debiting System (ADDS), which, compared to the ADS systems enable the payment to be effected without requiring the involved vehicle to stop.

 By way of exemplification, an ADDS system has been developed and is being utilized in Italy under the name "Telepass", which
30 provides a network of stationary ground based stations, arranged in positions corresponding to the inlet and outlet gates of highways and connected to a data processing central unit, which stations being in radio communication relationship with transceiver devices mounted upon vehicles and acting therefore as mobile apparatuses; in particular, the
35 mobile apparatuses are substantially transponder apparatuses. The stationary stations perform detection and classification tasks for the involved vehicles, identify the category allotted to the client, communicate the vehicle data received from the mobile apparatus to the data

processing central apparatus, in order to ascertain whether they match the data detected by the sensors. The central processing apparatus selects the rate to be applied, checks the solvency of the user and then transmits the results of these checks to the interested stationary station. The stationary station, upon receiving the results of the checks, carries out possible suitable procedures for handling the possible infractions, by operating, for instance, photographic cameras, in order to identify the infracting vehicle. Since, errors could be introduced during the initial communication stage between the stationary station and the mobile apparatus, provisions are made to reactivate the communication and to check the results of the data transfer, which should correctly be completed in a maximum time delay, beyond which the above said infraction handling procedures are started. Typically, the systems as presently available are adapted to handle vehicles travelling at a speed up to 80 Km/h, in the case of traffic channelled in single gangway passages, and up to 110 Km/h, in the case of unchannelled traffic in multiple gangway passages, based upon utilization of time division multiple access (TDMA) or frequency division multiple access (FDMA) techniques for signal transmission.

The requirements all ADDS systems, such as the Telepass system, should fulfil are rather severe and, therefore, they have some drawbacks.

In the first place, a sophisticated sensor system for vehicle classification is to be installed in each gangway of the passage monitored by the stationary station.

Furthermore, the radio bi-directional communication between stationary stations and mobile apparatuses should be realized by high performances radio systems, in order to reduce the disturbances connected with the reflection losses and with interferences.

In addition, the concerned stationary stations should be connected to the central data processing apparatus by means of a connection based upon very high performance lines and the central processing apparatus should be extremely powerful, in order to effect the data exchange and the check process in real time with the passage of the detected vehicle and in order to enable the whole network of stationary station to be suitably managed even in conditions of high traffic peaks.

Furthermore, it is necessary that the vehicle flow be unidirectional.

Furthermore, the vehicle flow should fulfil specific geometrical requirements, such as a minimum distance between the vehicles and a
5 minimum width of the gangways.

In addition, in the case of unchannelled traffic with multiple gangway passages, suitable procedures are needed to handle concurrent communications between stationary stations and multiple mobile
10 apparatuses.

Furthermore, a supplementary identification system, based upon photographic apparatuses, is needed to handle infraction cases.

Lastly, the Telepass type ADDS systems are so-called closed systems, under which term it is meant that, upon defining the stationary station, the characteristics of the mobile apparatuses are uniquely defined,
15 without any operation possibility between different systems or different protocols.

In addition to the above mentioned drawbacks, the ADDS systems above described in connection with payment of highway tolls cannot be adapted to operating as automatic debiting systems for
20 payment of tolls relating to different services, such as the toll access to urban areas and toll parking places.

Particularly in the case of un-guarded toll parking systems suitable ADDS approaches have not been suggested as yet, due to the difficult problem to check the parking of a very high number of vehicles in
25 areas with very high density of parking boxes for vehicles and/or motorcycles. All adopted solutions are based upon installation of specific apparatuses, so-called "parcometers", for advance payment of the parking toll for the expected duration. The parcometers are rather complex apparatuses, since they are provided with checking devices and money
30 counters as well as with printing machines for issuing the payment receipts to be arranged in visible position on the concerned vehicle.

The drawbacks of said parcometers are known : since they ought to be accessible, they are easily subject to tampering; the boxes collecting the money are to be emptied once or twice a day, with additional
35 costs for the related personnel; they require frequent maintenance intervets fort the components that are subject to all weather conditions; they need a suitable electric mains supply or a frequent battery substitution; since it is not economically feasible to have a parcometer

installed at each parking box, they cannot be easily utilized because the users are obliged to walk the distance from the vehicle to the parcometer a first time to make the due payment and a second time to place the payment receipt in the vehicle; it is necessary to employ a noticeable
5 number of dedicated personnel in order to check the payment receipts placed in the parked vehicles so as to ascertain whether the payment was duly made; the duration of the parking time should be beforehand evaluated by the users and, and, also in view of this requirement, the payment is made for extended time spans, generally for durations of hours
10 or half-hours; the rate applied cannot be easily modified; for the sake of practicity, the concerned parcometers should be very densely distributed and easily available, which means that their number should be high.

It is the object of this invention, therefore, to provide in simple, reliable and economic way an automatic charging or debiting system
15 adapted to be utilized for handling the distribution of various toll services and/or fines for infractions in connection with transportation means.

It is still an object of this invention to propose a system having component apparatuses that are scarcely cumbersome and can be easily installed and maintained.

20 A further object of this invention is to provide a debiting system of the abovesaid kind that can be easily up-dated.

Specific subject-matter of this invention is an automatic debiting system for transportation means, comprising a plurality of ground stationary stations, mobile apparatuses installed on board of the
25 transportation means and a central data processing apparatus, characterized in that each stationary station includes a radio transmitter, preferably of low power type, which sends a signal on a channel that can be received by the mobile apparatuses, in that said mobile apparatuses include a processing unit connected to a radio receiver tuned on said
30 channel, to a memory device and to a telecommunications device for carrying out communications with the data processing central apparatus, said processing central apparatus being provided with a telecommunication apparatus.

Preferably according to this invention, each stationary station
35 includes a radio receiver tuned to receive a broadcast signal that provides a unique sample time base.

According again to this invention, each stationary station can additionally include a sensor for detecting the presence of a transportation means.

5 Still according to this invention, the processing unit of said mobile apparatuses can include a microprocessor device, a non-volatile memory device, having the program executed by said microprocessor device stored therein, and a volatile memory device, said microprocessor device handling the operation of the mobile apparatus, said memory device including a non-volatile, at least partially re-programmable memory,
10 said radio receiver including a transit or buffer memory for storing the received data, as well as a comparator, said telecommunications device including a GSM radio-telephone and/or a PCN network terminal.

Further according to this invention, said processing unit is additionally connected to an alphanumeric display or to a keyboard.

15 Further features of this invention will be recited in the dependant claims.

This invention will be now described by way of illustration not by way of limitation according to its preferred embodiment, by particularly referring to the Figures of the enclosed drawings, in which :

20 Figure 1 schematically shows the system according to this invention;

Figure 2a shows a detail of a stationary station of the system according to this invention;

25 Figure 2b shows another detail of a stationary station of the system according to this invention; and

Figure 3 shows the preferred embodiment of the mobile apparatus of the system according to this invention.

30 By referring now to Figure 1, the system according to this invention includes a set of insulated or stand-alone stationary or fixed ground stations 1, mobile apparatuses installed on vehicles 2 and a data processing central apparatus 3. Even if the vehicles 2 are illustrated in the Figure as automobiles, it should be understood that they can be autovehicles and motor vehicles of any kind.

35 Each stationary station 1 includes a radio transmitter that transmits a signal on a channel 4 that can be received by said mobile apparatuses, such signal including data relating to the service supplier, to the service kind and to the current time and date; in particular, said radio transmitter can be activated by passage of a vehicle 2 and, in this case,

each stationary station 1 is provided with suitable detection sensors, but the radio transmitter can also be of a continuously operating type. The devices of the stationary stations 1 are preferably positioned at some meter altitude from the soil.

5 All mobile apparatuses include a radio receiver, a processing unit, that handles the whole mobile apparatus and stores the data furnished by the stationary station 1, as well as a telecommunications device for handling all communications with the data processing central apparatus 3.

10 Said data processing central apparatus 3 is provided with a telecommunications apparatus 5 by which it dialogues with said mobile apparatuses so as to receive the data stored therein since the last communication and to process them in order to debit the costs connected with the services utilized by vehicles 2. These communications are
15 activated by said data processing central apparatus 3 under such a schedule as to minimize their costs as well as the involved times, thereby fulfilling also possible specifications set forth by the suppliers of the various services and/or by the users in respect of the frequency such communications.

20 By referring to Figure 2a, a stationary station 1 includes a radio receiver 6, tuned for receiving a radio broadcast signal that furnishes a unique sample time base, for instance the signal transmitted by GPS satellites. A process and control unit 7 includes a microprocessor, a non-volatile memory device, that stores data relating to the stationary station 1
25 and the program executed by the microprocessor as well as a volatile memory device that stores the processing temporary data; said unit 7 manages the operation of all devices included in said stationary station 1 and obviously connected thereto and generates the signal transmitted by a low power radio transmitter 8 on said channel 4 adapted to be received by
30 said mobile apparatuses. In particular, such a signal can include codes relating to each specific stationary station 1 and/or to the service supplier and/or to the prevailing rate and data relating to the date and to the time of transmission.

35 Each stationary station 1 additionally includes an infrared sensor 9 aimed at detecting the presence of a vehicle 2; such a sensor 9 is not needed in all those cases in which transmitter 8 is of a continuously operating type. Lastly, a telecommunications device 10 is provided for connection to a central equipment designed for handling said stationary

station 1, related to the same service supplier, so as to enable a remote control of the stationary station 1 to be performed and/or the program executed by said process and control unit 7 to be up-dated. Telecommunications device 10 can also include a GSM and/or DECT radio telephone and/or a PCN network terminal and/or a cable based network terminal.

By referring now to Figure 2b, each stationary station 1 receives its power supply from one or more batteries 11 which are fed in turn by a mains supply 12 and/or by a solar panel device 12. On the other hand, it is to be remarked that the power requirements of a power supply needed for operation of a stationary station are not very severe, since the surface area to be covered by radiation from transmitter 8 is extremely restricted.

By referring now to Figure 3, the processing unit 14 provided in each mobile apparatus includes a microprocessor device, a non-volatile memory device, having the program executed by said microprocessor device stored therein, as well as a volatile memory device; said microprocessor device manages the operation of the whole mobile apparatus.

The above mentioned processing unit 14 is connected to a non-volatile memory device 15 that is at least partially re-programmable and includes, for instance an Electrically Erasable Programmable Read Only Memory (EEPROM) having all data of the vehicle stored therein, such as the registration data, as well as all possibly encrypted data relating to utilization of the services handled by the concerned automatic debiting system. The above mentioned non-volatile memory device is buried within the framework of the vehicle, so as to be unremovable and mechanically protected, and it is additionally provided with external connections to the power supply and to processing unit 14, which performs therein all data read and write operations relating to the utilization of the concerned services. The above mentioned device 15 is additionally protected against any undue data tampering attempt, like the protections exploited in connection with the so-called fiscal memories of the cash registers in public commercial shops.

The above said processing unit 14 is further connected to an alphanumeric visual screen or display 16 and to a keyboard 17 for displaying and entering data and/or for selecting the operation mode of the mobile apparatus.

The processing unit 14 is also connected to a communication channel or bus 18 by which it can dialogate with any further device as provided by said mobile apparatus and hereinbelow described.

5 A receiver 19, tuned on the transmission frequencies of transmitters 8 of said stationary stations 1, includes a transit memory or buffer, for storing the received data, as well as a comparator.

10 A telecommunications device 20 designed for dialogating with said data processing central apparatus 3 can include a GSM radio telephone and/or PCN network terminal. Preferably, said device 20 includes a card reader and it can be utilized also as a conventional telephone device.

An interface device 21 allows an external radio telephone to be utilized for communicating with the data processing central apparatus 3.

15 A first removable unit 22 includes a non-volatile at least partially re-programmable memory device which stores the same data as the memory device 15, as well as a telephonic modem. The first removable unit 22 can also be disconnected from the mobile apparatus and connected to a ground telephone network, thereby offering a further data transmission mode to the processing central apparatus 3.

20 A credit card reader 23 enables the costs connected with utilization of services to be directly debited to a credit card.

25 A second removable unit 24 includes a non-volatile at least partially re-programmable memory device, in which the same data as the memory device 15 are stored, as well as an interface device that enables the connections to external apparatuses for immediate payments, such as sale points with bancomat card readers.

30 A reader/writer 25 for pre-paid magnetic cards and a reader/writer 26 for pre-paid micro-chip cards enable the costs connected with utilization of services to be immediately debited, by subtracting those costs from the credit amounts stored on the corresponding pre-paid cards.

For a better comprehension of the present invention, the operation modes of the preferred embodiment of the automatic debiting system will be hereinbelow described.

35 At any place where a vehicle 2 is subject to a cost connected with utilization of a service, a stationary station 1 is installed for transmitting to the restricted underlying area all data relating to the service and to the date and time of utilization. When the concerned vehicle passes near said stationary station 1, the associated mobile apparatus receives

the signal transmitted from the gate and stores the data relating to the service into said non-volatile memory device 15 (as well as into similar devices of the first and second removable units 22 and 24). The data processing central apparatus 3 provides for establishing a communication link with the telecommunications device 20 of the mobile apparatus, thereby receiving the data stored in said memory device 15 in respect of all services utilized since the last communication and debiting their costs to the account of the user who is the owner of the mobile apparatus. In particular, said communications can be scheduled so as to be activated in the time bands in which the costs and/or the communications traffic are minimum, for instance during the night hours and at a rate established by the service suppliers and/or by the users.

When a credit card is inserted into reader 23 of the mobile apparatus, the above mentioned processing unit 14 also stores the data relating to the credit card inserted into said memory device 15 so that, when such data is read from the data processing central apparatus 3, the costs can be debited to the account corresponding to the concerned credit card. Similarly, when a pre-paid magnetic card or a pre-paid microchip card is inserted into said reader/writer 25 or into said reader/writer 26, respectively, the above said processing unit 14, upon ascertaining its solvency, subtracts the due costs from the amount stored in the inserted card and also stores a suitable indication of end of transaction in the above mentioned memory device 15.

As above outlined, it is also possible for the user to disconnect the first removable unit 22 by connecting it to a ground telephone network or to connect a radio telephone to said interface device 21 in order to activate the communication link and the exchange of data with the processing central apparatus 3. It is also possible for the user to disconnect the second removable unit 24 by connecting it to an external counter window for effecting an immediate payment.

By way of exemplification, when the service utilized is the transit on a toll highway, a stationary station 1 is provided at each access/exit gangway of the highway. When a vehicle 2 moves near to said stationary station 1, an infrared sensor 9 detects its presence and activates transmitter 8 for an a priori established time duration, for transmitting the signal including the data relating to the highway access/exit gangway as well as to the passage date and time, for storing such data in the mobile apparatus. Such an operation is repeated both on

accessing to and on exiting from the highway, in particular, even if it is possible to arrange a stationary station 1 for the access and a stationary station 1 for the exit in the same gangway, a single stationary station 1 will be sufficient, since its operation is independent of the movement directions of the vehicles, according to the above description. In fact, by suitably sizing the stationary station 1 so as to guarantee the coverage of the whole service area, both the access and the exit data are the same and they are processed by said mobile apparatus and/or by said data processing central apparatus 3.

Obviously, in all circumstances of high traffic density, it is convenient that the transmitters 8 of the stationary stations 1 be in continuous operation condition.

The feasibility of a correct data transmission from the stationary station 1 to the mobile apparatus can be evidenced by considering the conventional technical data of the involved component devices. In the assumption of a transfer rate B of 2 megabits per second, a length Q of 400 bits for the data string to be transmitted, a speed v of 200 km/h for vehicle 2 and a useful length L needed for transmission of 1 m, corresponding to the area covered by radiation from a low power transmitter at some meter altitude from the soil, it appears that the time t needed for transmitting a string is equal to

$$t = \frac{Q}{B} = \frac{400}{2 * 10^6} = 20 * 10^{-4} \text{ sec};$$

the distance D travelled by vehicle 2 in a time t is given by

$$D = v * t = 200 * \frac{1000}{3600} * 2 * 10^{-4} = 1,1cm;$$

in the assumption that, in the worst case, the transmission of the first string is considered as failed due to lack of the first bit, the number N of 400 bit strings received by vehicle 2, travelling at a speed of 200 km/h, in a distance of 1 m, is given by

$$N = \frac{100}{1.1} - 1 = 89.9;$$

in other words, the mobile apparatus installed on vehicle 2 will receive 89 times the complete string; when it is desired to eliminate any possibility of transmission error, in addition to the possibility to provide the transmitted strings with error correction codes, it is sufficient that said device 14 store the first string stored in the buffer section of receiver 19 which is detected by the comparator as constant for two or three consecutive transmissions. Obviously, when vehicle 2 travels at lower speeds, the situation is even more favourable, since the number N of 400 bit strings received by vehicle 2 is higher.

10 The operation mode for access and/or permanence services regulated on the base of a hourly determined toll or on a transit base in respect of specific urban areas is similar to the already described one.

When the toll service utilized is a parking service based upon a hourly determined rate, a stationary station 1 installed at the access to and/or at the exit from the parking area will be sufficient.

When all parking areas of a designated urban area are subject to toll payment, it will be sufficient to install the stationary stations in the perimetral roads of said urban area and to suitably program the mobile apparatus which is provided with an internal clock that is synchronized with the time in the stationary stations 1 each time it receives their signal, so that, when the engine of the vehicle is switched off, the parking begin time is recorded in the memory device 15 and, when the engine is re-started, the parking end time is recorded. The data processing central apparatus 3 can also be provided with control means that exclude particular users from payment of specific services, such as the access and parking services for all users domiciled in specific urban areas subject to payment of access and parking tolls.

25 The costs recorded in a mobile apparatus can be made visible on a display 16 and also a visual signal generator, such as light emitting diode or LED, can be provided for signalling the correct operation of the mobile apparatus to the control personnel.

30 Furthermore, the system according to this invention can also be utilized for recording the fines that become due in connection with infractions of the circulation rules; in this case the urban police men can be equipped with suitable transmitter provided with a keyboard for selecting the specific fine comminated.

35

In addition, it is also possible to provide stationary stations 1 connected to the fuel distributing columns for transmitting the refuelling costs.

5 The data processing central apparatus 3 is adapted to up-date the programs stored in the mobile apparatuses and to activate the management of further services that could become available.

10 It is also to be contemplated the possibility to install stationary stations along the roads in order to provide the drivers with suitable information, for instance the existence of a scarce visibility situation or information on the traffic conditions on the roads.

The mobile apparatuses can also be provided with a low power radio transmitter, for instance, an infrared transmitter, in order to transmit to a corresponding receiver arranged in the stationary station an information signal indicating the correct receipt (acknowledgement signal) of the signal transmitted by the stationary station and/or to operate as an interface unit for transmission to various external ITS systems, thereby making the mobile apparatus capable to dialogate both with ADDS systems and with ITS systems, that in presently available implementations are separate.

20 Since the communication between stationary stations 1 and mobile apparatuses is of simplex type, it is less complex than the presently available ADDS systems, such as Telepass, and consequently it is less likely than error occur in the transmission.

25 Obviously, the management of the debiting operations connected to different services can be distributed on a number of data processing central apparatuses 3.

Since all devices incorporated in the stationary stations are installed at some meter altitude from the soil, they are not easily accessible for tampering.

30 As far as the toll parking service is concerned, the stationary stations 1 allow a more comfortable utilization of the service, because it is no more necessary to look for a parcometer for advance payment of the parking toll, without jeopardizing the debiting operation activation. Furthermore, it is possible to debit a money amount strictly corresponding to the parking exact duration and it is also possible to modify the rate as a function of the hour bands and/or of the days in which the service is utilized.

35

It is also possible to encourage the utilization of particular roads and/or parking places by causing the data processing central apparatus 3 to credit rather than debiting corresponding money amounts to vehicles travelling in such roads and/or parking in such parking places.

5 This invention has been hereinbefore explained by way of illustration, but not by way of limitation, according to its preferred embodiment, but it should be understood that those skilled in the art can made variations and/or changes therein without departing from the scope of this invention, as defined in the attached claims.

10

CLAIMS

1.- An automatic debiting system for transport means comprising a plurality of ground stationary stations (1), mobile apparatuses installed on board of the transportation means (2) and a central data processing apparatus (3), characterized in that each stationary station (1) includes a radio transmitter (8), which sends a signal on a channel (4) that can be received by the mobile apparatuses, in that said mobile apparatuses include a processing unit (14, 16, 17, 18, 23, 24, 25, 26) connected to a radio receiver (19) tuned on said channel (4), to a memory device (15) and to a telecommunications device (20, 21, 22) for carrying out communications with the data processing central apparatus (3), said processing central apparatus (3) being provided with a telecommunication apparatus (5).

2.- A system according to claim 1, characterized in that the radio transmitters (8) of the stationary stations (1) are of low power.

3.- A system according to claim 1 or 2, characterized in that each stationary station (1) includes a radio receiver (6) tuned in order to receive a radio broadcast signal that furnishes a unique sample time base.

4.- A system according to any one of the preceding claims, characterized in that each stationary station (1) also includes a control and processing unit (7) including a microprocessor, a non-volatile memory device, that stores all data relating to said stationary station (1) as well as the program executed by said microprocessor, and a volatile memory device, said control and processing unit (7) managing the operation of said stationary station (1).

5.- A system according to any one of the preceding claims, characterized in that each stationary station (1) further includes a sensor (9) for detecting the presence of a transport means (2).

6.- A system according to any one of the preceding claims, characterized in that said stationary stations (1) are connected to a central control apparatus by means of a telecommunications device (10).

7.- A system according to claim 6, characterized in that said telecommunications device (10) includes a GSM and/or DECT radio telephone and/or a PCN network terminal and/or a cable based network terminal.

8.- A system according to claim 4 and any one of claims 6 or 7, characterized in that said central control apparatus is adapted to up-date

the program executed by the microprocessor of said processing and control unit (7).

5 9.- A system according to any one of the preceding claims, characterized in that said processing unit (14) includes a microprocessor, a non-volatile memory device, having the program executed by said microprocessor device stored therein, and a volatile memory device, said microprocessor device handling the operation of the mobile apparatus, said memory device (15) including a non-volatile, at least partially re-
10 programmable memory, said radio receiver (19) including a transit or buffer memory for storing the received data, as well as a comparator, said telecommunications device (20) including a GSM radio-telephone and/or a PCN network terminal.

15 10.- A system according to claim 9, characterized in that said non-volatile memory device (15) includes an Electrically Erasable Programmable Read Only Memory (EEPROM).

20 11.- A system according to claim 9 or 10, characterized in that said non-volatile memory device (15) is buried within the framework of the vehicle, so as to be unremovable and mechanically protected, and it is additionally provided with external connections to the power supply and to said processing unit (14) and it is protected against any undue data tampering attempt.

25 12.- A system according to any one of the preceding claims 9 to 11, characterized in that said processing unit (14) is further connected to an alphanumeric visual screen or display (16) and to a keyboard (17).

30 13.- A system according to any one of the preceding claims 9 to 12, characterized in that said telecommunications device (20) further includes a card reader.

35 14.- A system according to any one of the preceding claims 9 to 13, characterized in that said processing unit (14) is further connected to an interface device (21) to an external radiotelephone.

40 15.- A system according to any one of the preceding claims 9 to 14, characterized in that said processing unit (14) is further connected to a first removable unit (22) including a non-volatile at least partially re-programmable memory device, as well as a telephonic modem.

45 16.- A system according to any one of the preceding claims 9 to 15, characterized in that said processing unit (14) is further connected to a credit card reader (23).

17.- A system according to any one of the preceding claims 9 to 16, characterized in that said processing unit (14) is further connected to a second removable unit (24) including a non-volatile at least partially re-programmable memory device, as well as an interface device.

5 18.- A system according to any one of the preceding claims 9 to 17, characterized in that said processing unit (14) is further connected to a reader/writer (25) for pre-paid magnetic cards and/or to a reader/writer (26) for pre-paid micro-chip cards.

10 19.- A system according to any one of the preceding claims, characterized in that said mobile apparatuses are further provided with a radio transmitter that communicates with a correspondent receiver of the stationary stations (1).

15 20.- An automatic debiting system for transport means, according to any one of the preceding claims, substantially as illustrated and described.

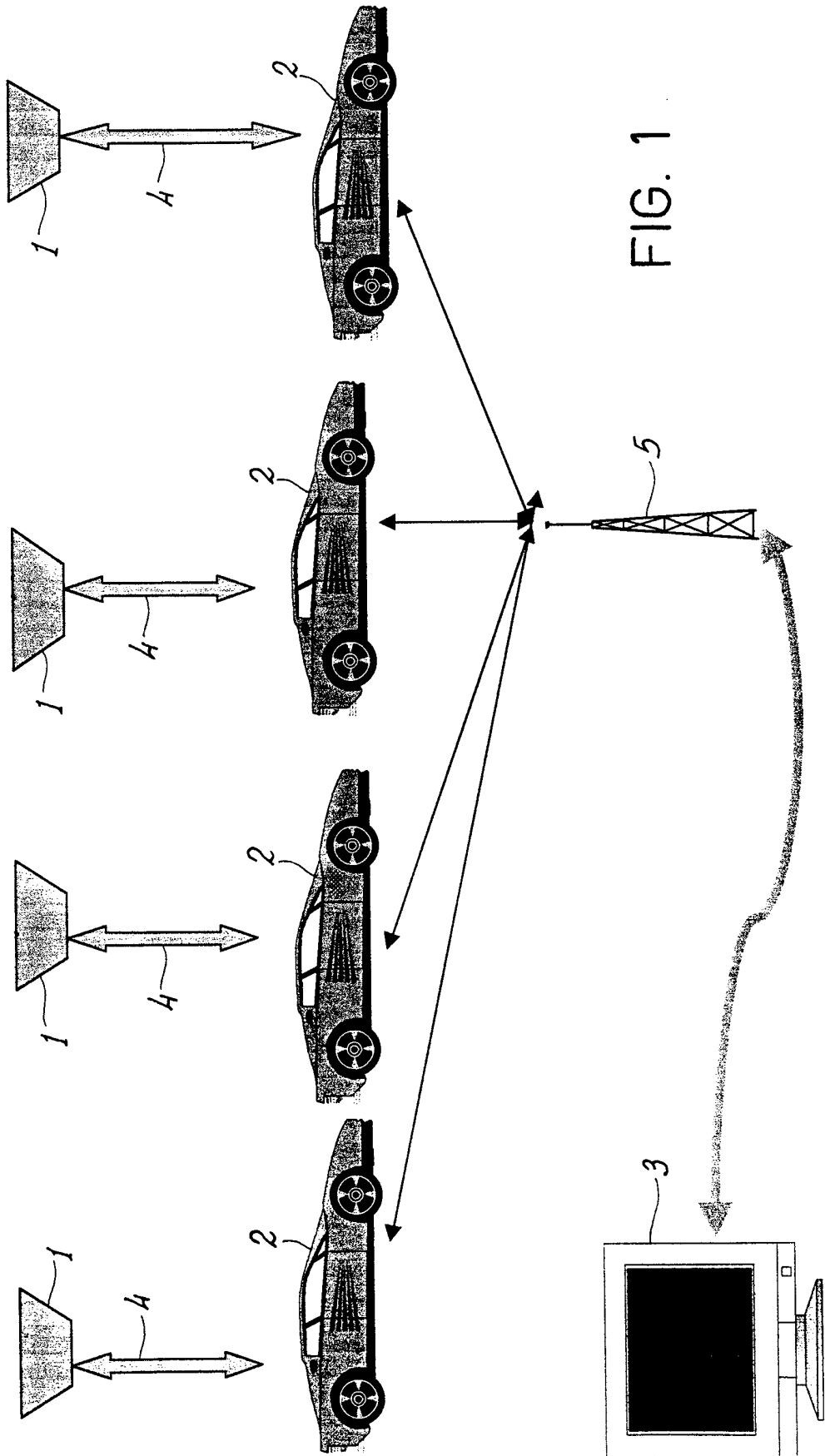

FIG. 1

FIG. 2a

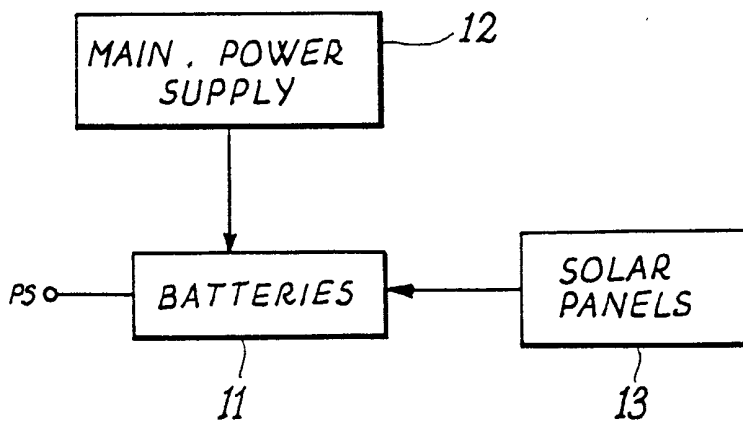
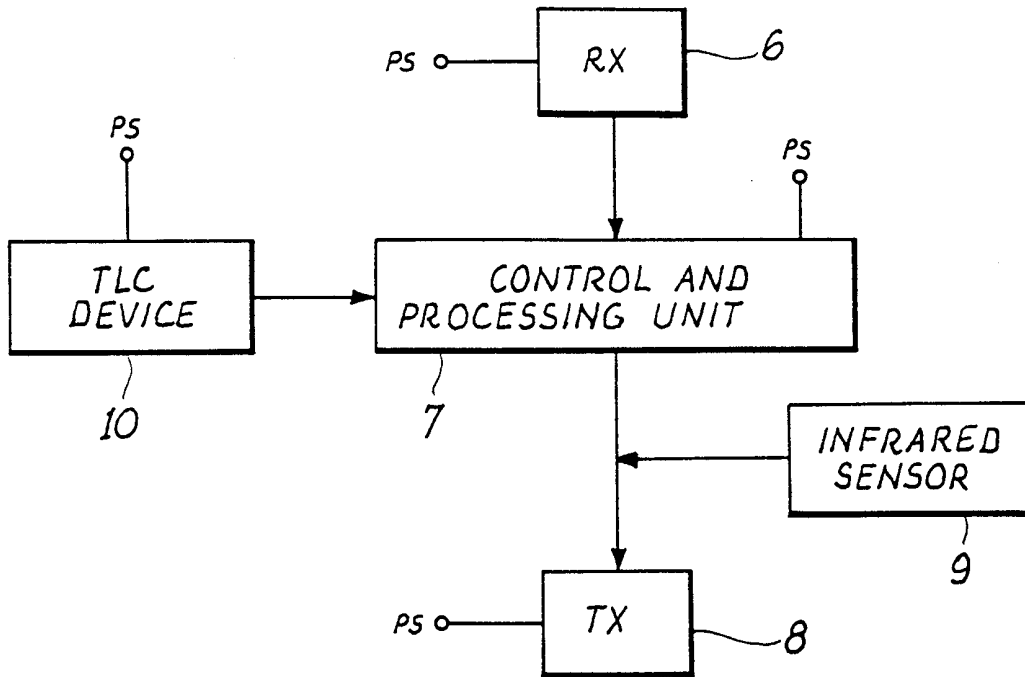
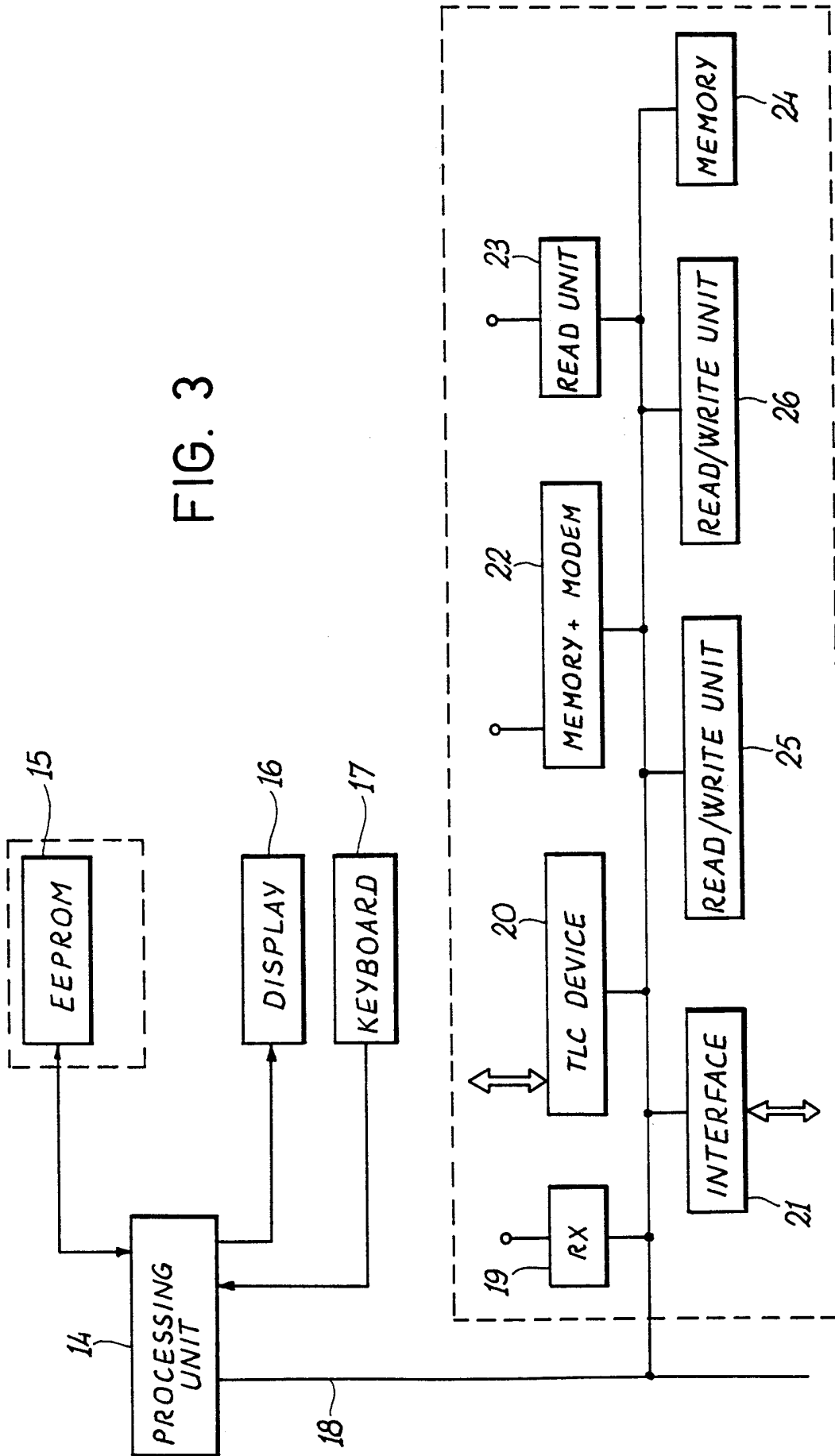

FIG. 2b

FIG. 3



INTERNATIONAL SEARCH REPORT

Int'l Application No
PCT/IT 00/00024

A. CLASSIFICATION OF SUBJECT MATTER IPC 7 G07B15/00 According to International Patent Classification (IPC) or to both national classification and IPC		
B. FIELDS SEARCHED Minimum documentation searched (classification system followed by classification symbols) IPC 7 G07B G07C Documentation searched other than minimum documentation to the extent that such documents are included in the fields searched Electronic data base consulted during the international search (name of data base and, where practical, search terms used)		
C. DOCUMENTS CONSIDERED TO BE RELEVANT		
Category *	Citation of document, with indication, where appropriate, of the relevant passages	Relevant to claim No.
X	US 5 289 183 A (KOWAL KEITH E ET AL) 22 February 1994 (1994-02-22) abstract; figures column 2, line 32 - line 53 column 3, line 25 -column 5, line 41 column 5, line 64 -column 7, line 44	1,2,4-6, 8,19,20
Y	---	9,13,14, 16,18
X	US 5 694 322 A (KENNEDY III WILLIAM C ET AL) 2 December 1997 (1997-12-02) abstract; figures 1,9,10 column 3, line 8 -column 5, line 32 column 7, line 30 - line 37 column 16, line 20 -column 19, line 17 --- -/--	1-3,9, 12,14,20
<input checked="" type="checkbox"/> Further documents are listed in the continuation of box C. <input checked="" type="checkbox"/> Patent family members are listed in annex.		
* Special categories of cited documents : *A* document defining the general state of the art which is not considered to be of particular relevance *E* earlier document but published on or after the international filing date *L* document which may throw doubts on priority claim(s) or which is cited to establish the publication date of another citation or other special reason (as specified) *O* document referring to an oral disclosure, use, exhibition or other means *P* document published prior to the international filing date but later than the priority date claimed *T* later document published after the international filing date or priority date and not in conflict with the application but cited to understand the principle or theory underlying the invention *X* document of particular relevance; the claimed invention cannot be considered novel or cannot be considered to involve an inventive step when the document is taken alone *Y* document of particular relevance; the claimed invention cannot be considered to involve an inventive step when the document is combined with one or more other such documents, such combination being obvious to a person skilled in the art. *&* document member of the same patent family		
Date of the actual completion of the international search		Date of mailing of the international search report
12 May 2000		19/05/2000
Name and mailing address of the ISA European Patent Office, P.B. 5818 Patentlaan 2 NL - 2280 HV Rijswijk Tel. (+31-70) 340-2040, Tx. 31 651 epo nl, Fax: (+31-70) 340-3016		Authorized officer Buron, E

INTERNATIONAL SEARCH REPORT

Int'l Patent Application No

PCT/IT 00/00024

C.(Continuation) DOCUMENTS CONSIDERED TO BE RELEVANT		
Category °	Citation of document, with indication, where appropriate, of the relevant passages	Relevant to claim No.
X,P	WO 99 33027 A (COMBITECH TRAFFIC SYST AB ;ERIKSSON KENT (SE)) 1 July 1999 (1999-07-01) abstract; figures page 4, line 14 -page 10, line 11 ---	1,6-9, 12-14, 16,18-20
Y	GB 2 326 009 A (FRESHFIELD COMMUNICATIONS LIMI) 9 December 1998 (1998-12-09) abstract; figures 1,2 page 3, line 11 -page 8, line 7 page 10, line 17 -page 13, line 19 ---	9,13,14, 16,18
A	WO 97 13208 A (SCIENTIFIC ATLANTA ;HOUSER PETER B (US)) 10 April 1997 (1997-04-10) abstract; figures 1,3,4 page 17, line 7 -page 19, line 13 ---	9-14, 16-19
A	DE 93 20 758 U (MANNESMANN AG) 5 January 1995 (1995-01-05) claims 1,2 ---	1,9,20
A	DE 43 35 317 A (DETECON GMBH) 20 April 1995 (1995-04-20) -----	

INTERNATIONAL SEARCH REPORT

Information on patent family members

International Application No

PCT/IT 00/00024

Patent document cited in search report		Publication date	Patent family member(s)	Publication date
US 5289183	A	22-02-1994	US 5805082 A US 5751973 A US 5347274 A	08-09-1998 12-05-1998 13-09-1994
US 5694322	A	02-12-1997	AU 5488196 A EP 0824731 A WO 9636018 A US 5970481 A	29-11-1996 25-02-1998 14-11-1996 19-10-1999
WO 9933027	A	01-07-1999	SE 510080 C AU 1988399 A SE 9704853 A	19-04-1999 12-07-1999 19-04-1999
GB 2326009	A	09-12-1998	NONE	
WO 9713208	A	10-04-1997	NONE	
DE 9320758	U	05-01-1995	DE 4332883 A AT 149718 T AU 6645194 A WO 9428513 A DE 59401962 D EP 0700550 A ES 2098937 T	08-12-1994 15-03-1997 20-12-1994 08-12-1994 10-04-1997 13-03-1996 01-05-1997
DE 4335317	A	20-04-1995	NONE	