

(No Model.)

2 Sheets—Sheet 1.

R. A. L. SNYDER & A. F. TINNERHOLM.

ELECTRIC HEATING APPARATUS.

No. 566,545.

Patented Aug. 25, 1896.

Fig. 1.

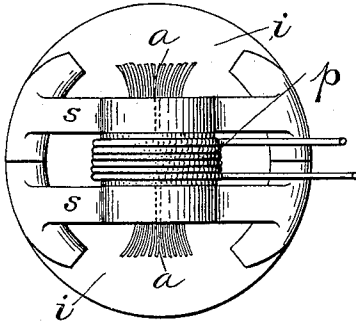

Fig. 2.

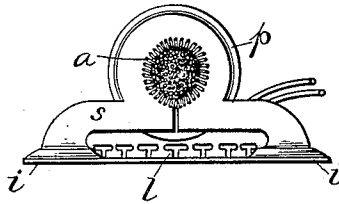

Fig. 3.

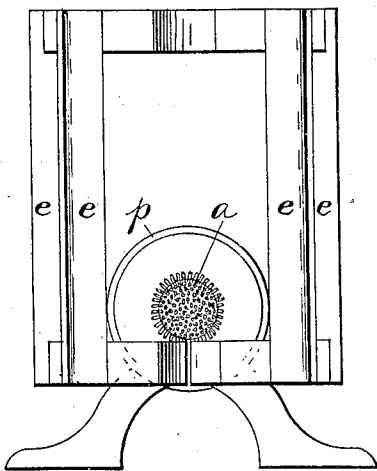
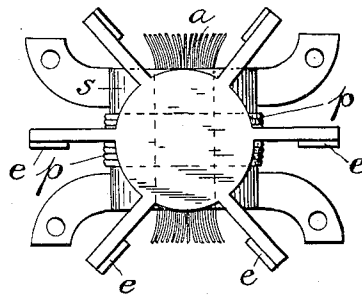

Fig. 4.



Witnesses:

James Blackwood
W. P. Doolittle

Inventors

Richard A. L. Snyder
& August F. Tinnerholm
 by *W. P. Doolittle & Son*
 Attorneys

R. A. L. SNYDER & A. F. TINNERHOLM.

ELECTRIC HEATING APPARATUS.

No. 566,545.

Patented Aug. 25, 1896.

Fig. 6.

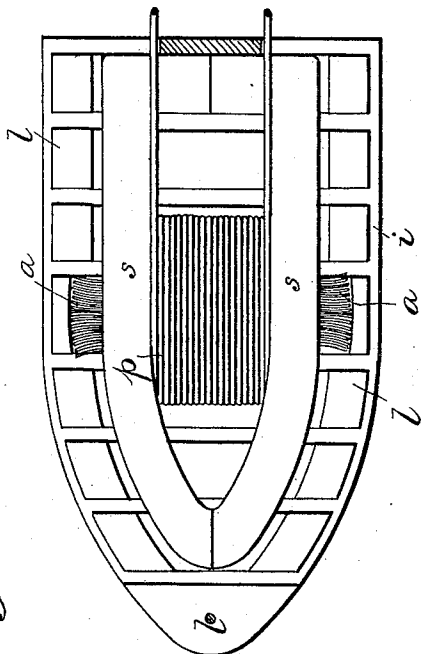

Fig. 5.

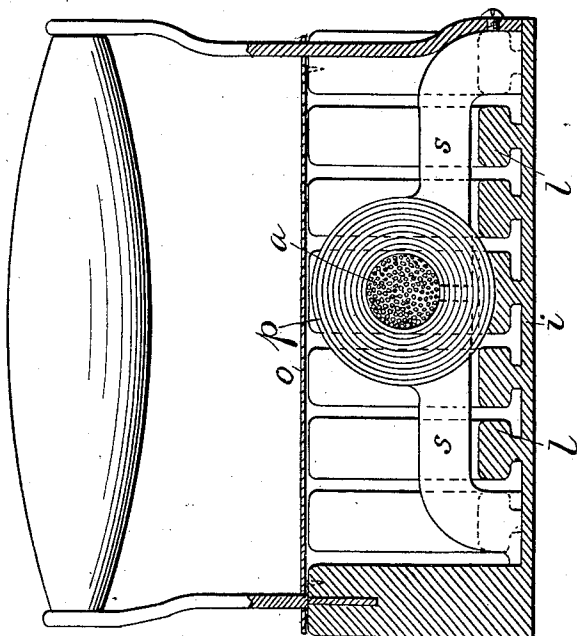
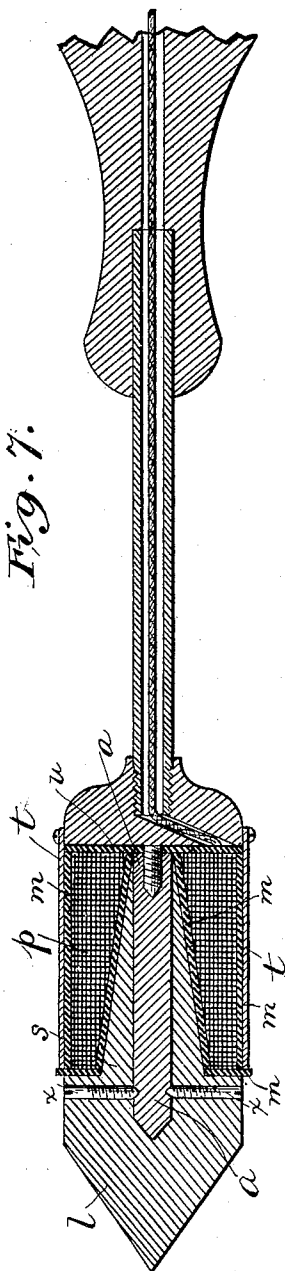

Fig. 7.



Witnesses:

Just H. Glaetwood
W. P. Doolittle.

Inventors:
Richard A. L. Snyder
& August F. Tinnerholm
by W. P. Doolittle & Son
 Attorneys

UNITED STATES PATENT OFFICE.

RICHARD A. L. SNYDER AND AUGUST F. TINNERHOLM, OF PITTSBURG,
PENNSYLVANIA, ASSIGNORS TO THE AMERICAN ELECTRICAL HEATER
COMPANY, OF DETROIT, MICHIGAN.

ELECTRIC HEATING APPARATUS.

SPECIFICATION forming part of Letters Patent No. 566,545, dated August 25, 1896.

Application filed July 23, 1895. Serial No. 556,908. (No model.)

To all whom it may concern:

Be it known that we, RICHARD A. L. SNYDER and AUGUST F. TINNERHOLM, citizens of the United States, residing at Pittsburg, in the county of Allegheny and State of Pennsylvania, have invented certain new and useful Improvements in Electric Heating Apparatus; and we do hereby declare the following to be a full, clear, and exact description of the invention, such as will enable others skilled in the art to which it appertains to make and use the same.

Our invention relates to improvements in electric heating apparatus, and more especially to that class of electric heating apparatus in which an induced current of electricity is employed.

In electric heating apparatus of this class heretofore generally employed great difficulty has been encountered by reason of the primary coil becoming too hot and frequently burning out. The prime objects of our invention are to obviate this serious difficulty, to concentrate the heat at the point where required, and at the same time to produce a simple and durable apparatus. These objects we attain by the construction and arrangement of parts, as more fully hereinafter described and particularly claimed.

Our invention is illustrated in the accompanying drawings, in which we have shown our invention as applied to various forms of heating devices.

Figure 1 is a plan view of our invention as applied to heating a flat plate; Fig. 2, an end view of same; Fig. 3, an end view of a radiator embodying our invention; Fig. 4, a plan view showing arms of radiator; Fig. 5, a sectional view of a flat-iron; Fig. 6, a plan view of same, and Fig. 7 a cross-section of a soldering-iron.

Like letters of reference indicate like parts throughout the several figures.

Referring to the drawings, *a* indicates a soft-iron core, either solid or made up of wires.

s is made of copper, iron, or other suitable material, and constitutes the short-circuited secondary surrounding the iron core *a*.

l are metal lugs attached to the secondary

in such a manner as to collect the heat from the secondary, store it up when not being utilized, and give it out when and where required without materially lowering the resistance of the secondary.

p is the primary coil, placed either on the outside of the secondary *s* or between it or partly over it, as is shown by the drawings. By the use of this construction we are enabled to prevent the primary from burning out, part of its surface being exposed for radiation. As a further safeguard, we wind the primary coil with asbestos-covered wire.

Suitable insulating material is employed in the construction of the various styles of apparatus to which our invention is adapted.

To enable our invention to be better understood, we have thought it best to show it applied to various forms of heating apparatus, and we will refer to these forms in detail.

In Figs. 1 and 2 we have shown a construction adapted for heating a flat plate *i* for use in connection with various cooking utensils, &c. Here we have shown the primary coil *p* placed between the secondary, by which construction it is impossible for the primary to become too hot and burn out. The plate *i* and the heavy parts *s* constitute the short-circuited secondary. Plate *i* is made of iron or other suitable material and provided with lugs *l*. The resistance of the plate *i* should be relatively high compared with the other parts of the secondary, and at the same time have some capacity for storing up heat when the current is on and the heater not in use. The form of the secondary *s* is made of one turn, and is of as little resistance as possible without being too bulky. It has been proven that a full-loaded hedgehog-transformer is more efficient than a full-loaded transformer with a closed magnetic circuit. For this reason we simply insert an iron core *a*, as shown.

Figs. 3 and 4 show a radiator for heating rooms. Instead of the plate *i* of Figs. 1 and 2 we employ long strips of iron *e* in the secondary circuit, as shown in Figs. 3 and 4. These strips are attached to a spider-casting at the top, so as to hold the strips apart and

permit their heat to radiate. In other respects the radiator is like the heater shown in Figs. 1 and 2.

In Figs. 5 and 6 we show our invention applied to a flat-iron, in which a is the iron core; i , the plate to be heated, and which also forms part of the secondary circuit. p is the primary coil placed between the secondary s , but with part of its surface exposed. The lugs l serve to collect the heat when the current is on and the flat-iron not in use, but when the flat-iron is in use the heat is given up very rapidly by the plate i , and as the temperature of the plate falls below that of the lugs the heat commences to flow through the necks of the lugs back into the plate, thus helping it keep up the heat of the plate i , or, in other words, the lugs act as a heat-reservoir. Just over the top of the heating apparatus is placed some good non-heat-conducting substance o , as asbestos, for the purpose of turning all the heat possible down through the face of the flat-iron.

Fig. 7 shows a longitudinal cross-section of a soldering-iron. a is the iron core held in the secondary s by soft-iron screws x , which constitute part of the magnetic circuit. On the forward end of the secondary s is an enlarged projection or lug l , made of copper or other suitable material, which also serves as the tip for the soldering-iron. It may be made integral with the secondary or may be a separate piece and suitably attached thereto. The cross-section of the secondary s is increased in area as it approaches the part or projection l for the purpose of more readily delivering its heat to said lug or tip l . Practically nearly all the heat will be developed in the secondary s , which is tapered to a very small section toward the end farthest from the tip, so as to offer as little surface for heat radiation in that direction as possible. p is the primary coil, wound on the outside of the secondary and insulated therefrom by a thin layer of mica or other suitable insulation, by which arrangement the primary will be kept comparatively cool, its inner surface only being exposed to a source of heat. Over the primary and around the ends is placed some good non-heat-conducting substance m , and over this is placed a thin metal shell t for mechanical protection. The shell t is split down one side, so that it will not form a second short-circuited conductor that would radiate its heat to the air. w is a washer made of

mica or some other non-heating material, placed between the iron and its handle to prevent the heat from going in the direction of the handle.

Having thus fully described our invention, 60 what we claim is—

1. In an electric heating apparatus, an open magnetic core, a short-circuited secondary entirely surrounding the said core, a primary coil wound on the outside of the said short-circuited secondary, substantially as described. 65

2. In an electric heating apparatus, a short-circuited divided secondary formed of the heavy parts of low resistance and one or more plates or strips of comparatively high resistance provided with heat-storing lugs, a soft-iron core running through the heavy parts of said secondary circuit, a primary coil wound on the outside of the core and placed between the heavy parts of the said secondary, but insulated therefrom, substantially as described. 70 75

3. In an electric heating apparatus, a conductor, consisting of a plate or strips, provided with lugs or projections so attached as to greatly increase the heat capacity of the conductor without very much increasing the conductivity, thereby allowing the heat to be stored up in said lugs or projections and given out as needed, substantially as described. 80 85

4. In an electric heating apparatus, a short-circuited secondary provided with a projection, the cross-section of said secondary increasing in area as it approaches the projection, an iron core embedded in said secondary, iron screws passing through the said projection to hold the core in place, a primary coil wound on and surrounding the secondary, but insulated therefrom, substantially as described. 90 95

5. In an electric heating apparatus, a short-circuited secondary, the cross-section of said secondary increasing in area toward the point to be heated, an iron core embedded in said secondary, a primary coil, said primary coil wound on and surrounding the secondary, but insulated therefrom, substantially as described. 100

In testimony whereof we affix our signatures in presence of two witnesses.

RICHARD A. L. SNYDER.

AUGUST F. TINNERHOLM.

Witnesses:

JOHN M. PRESCOTT, Jr.,
W. G. DOOLITTLE.