



US00D720327S

(12) **United States Design Patent**
Kishita et al.

(10) **Patent No.:** **US D720,327 S**

(45) **Date of Patent:** **** Dec. 30, 2014**

(54) **PROCESS CONTROL INSTRUMENT**

(56) **References Cited**

(71) Applicant: **Mitsubishi Heavy Industries, Ltd.**,
Tokyo (JP)

(72) Inventors: **Koichi Kishita**, Tokyo (JP); **Kazuyuki Misawa**, Tokyo (JP); **Kenichi Morimoto**, Tokyo (JP); **Yuichi Yakushiji**, Tokyo (JP); **Sumiko Takeda**, Tokyo (JP)

(73) Assignee: **Mitsubishi Heavy Industries, Ltd.**,
Tokyo (JP)

U.S. PATENT DOCUMENTS

D339,102	S	*	9/1993	Boyd	D13/110
D372,017	S	*	7/1996	Suematsu et al.	D13/110
D374,861	S	*	10/1996	Mousa	D13/110
D376,347	S	*	12/1996	Mousa	D13/110
D506,976	S	*	7/2005	Dechene et al.	D13/110
D511,137	S	*	11/2005	Tuomola et al.	D13/110
D553,564	S	*	10/2007	Kuo	D13/110
D561,095	S	*	2/2008	Sakai et al.	D13/110
D606,937	S	*	12/2009	Brookshire et al.	D13/110
D621,350	S	*	8/2010	Huang et al.	D13/110
D657,310	S	*	4/2012	Fahrendorff et al.	D13/110
D705,162	S	*	5/2014	Mueller et al.	D13/110

* cited by examiner

Primary Examiner — Caron D Veynar
Assistant Examiner — Holly E Thurman
(74) *Attorney, Agent, or Firm* — Birch, Stewart, Kolasch & Birch, LLP

(**) Term: **14 Years**

(21) Appl. No.: **29/461,934**

(22) Filed: **Jul. 29, 2013**

(57) **CLAIM**
The ornamental design for a process control instrument, as shown and described.

(30) **Foreign Application Priority Data**

Jan. 30, 2013 (JP) 2013-001742

(51) **LOC (10) Cl.** **14-03**

(52) **U.S. Cl.**
USPC **D14/140.2**

(58) **Field of Classification Search**
CPC H02B 1/056; H02B 1/28; H02B 1/32;
H02B 11/24; H01R 13/447
USPC D14/140.1, 140.2, 140.3, 144, 147, 148,
D14/149, 150, 151, 300, 301, 302, 308, 311,
D14/312, 349, 353, 354, 356, 357, 358;
D10/49, 123; D13/110, 139.1, 162,
D13/162.1, 164, 177; 174/50; 361/600, 622;
455/128, 347

DESCRIPTION

FIG. 1 is a perspective view of a process control instrument. FIG. 2 is a front elevation view thereof. FIG. 3 is a rear elevation view thereof. FIG. 4 is a left side elevation view thereof. FIG. 5 is a right side elevation view thereof. FIG. 6 is a top plan view thereof. FIG. 7 is a bottom plan view thereof. FIG. 8 is a cross-sectional view taken along the line 8-8 in FIG. 2, which omits the internal structure; and, FIG. 9 is a cross-sectional view taken along the line 9-9 in FIG. 2, which omits the internal structure. The portions of the process control instrument shown in broken lines are for the purpose of showing environmental structure only and form no part of the claimed design. The dash-dot-dash line represents the boundary of the claimed design and forms no part thereof.

See application file for complete search history.

1 Claim, 9 Drawing Sheets

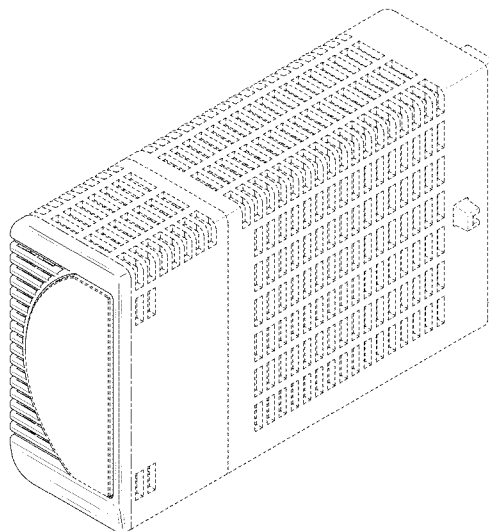

FIG. 1

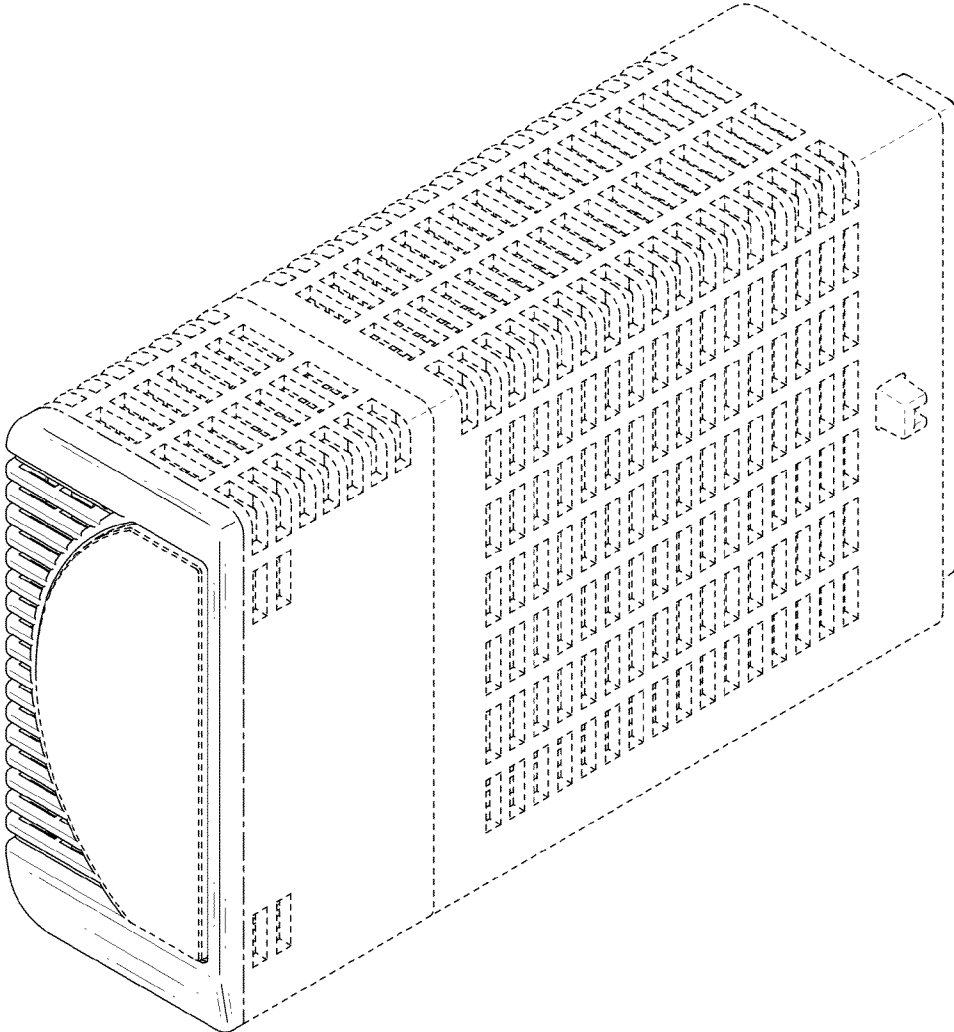

FIG. 2

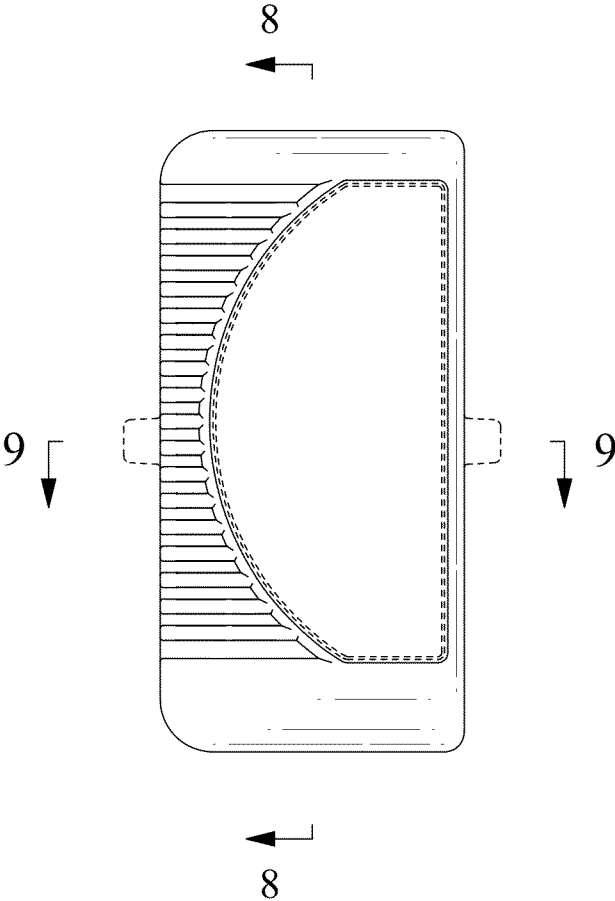

FIG. 3

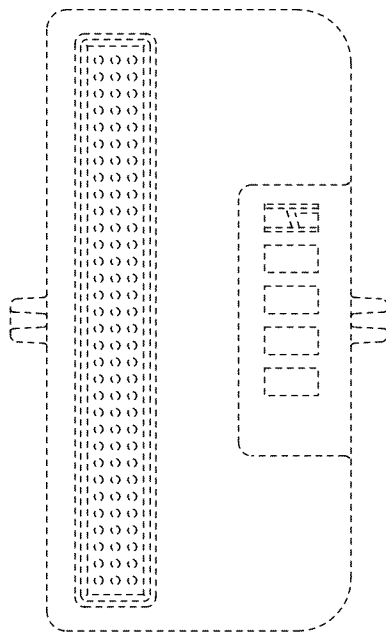

FIG. 4

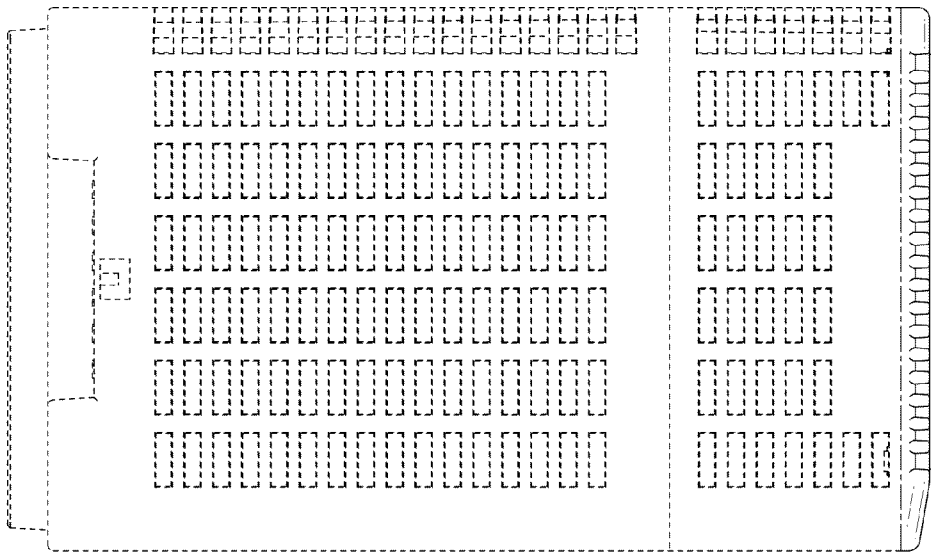

FIG. 5

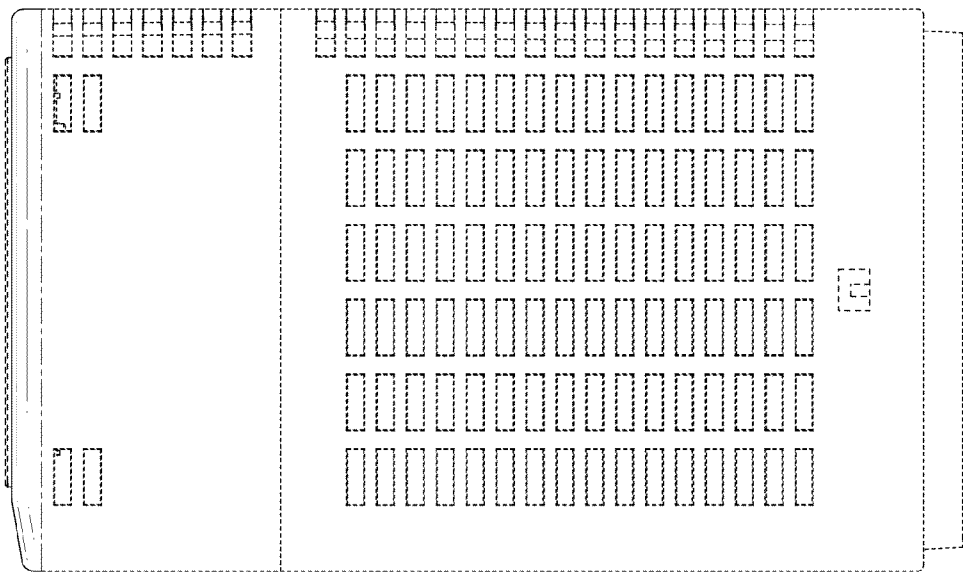

FIG. 6

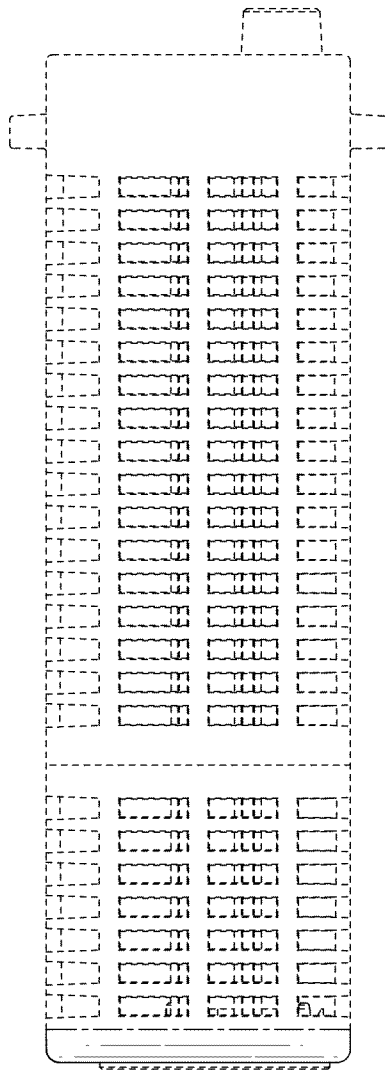

FIG. 7

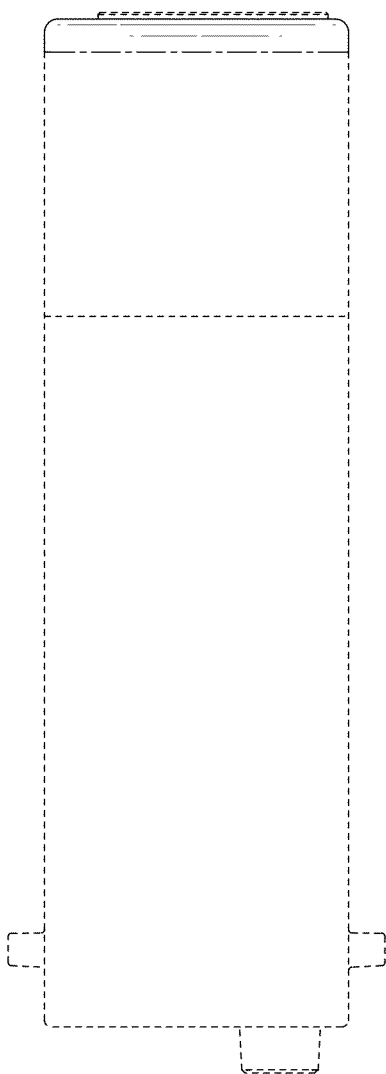

FIG. 8

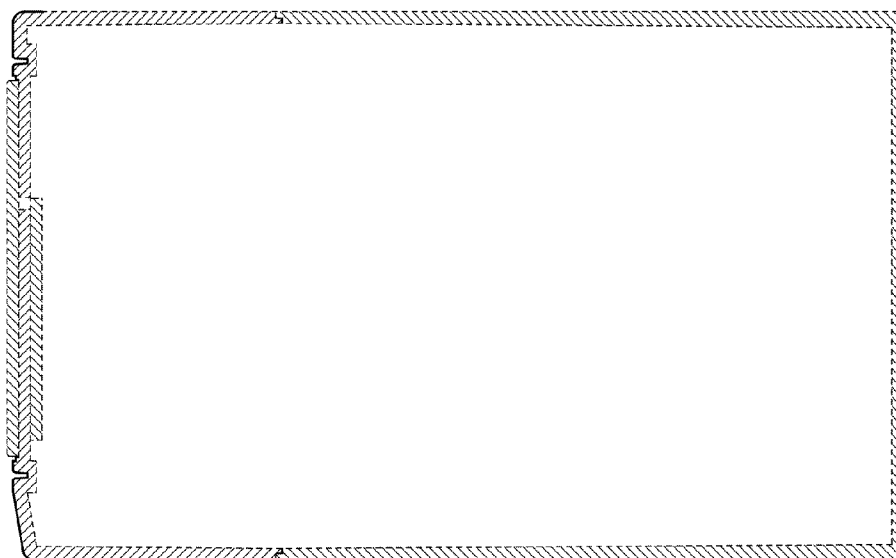

FIG. 9

