

19



ORGANISATION AFRICAINE DE LA PROPRIETE INTELLECTUELLE

51

Inter. Cl.⁸ B42F 1/00 (06.01)

11

N° 17559

FASCICULE DE BREVET D'INVENTION

21

Numéro de dépôt : 1201500351

22

Date de dépôt : 27/08/2015

30

Priorité(s) :

US n° 62/043,963 du 29/08/2014

24

Délivré le : 30/06/2016

45

Publié le : 13.02.2017

73

Titulaire(s) :

ESCO Corporation,
2141 NW 25th Avenue,
PORTLAND 97210-2578, OR (US)

72

Inventeur(s) :

Paul, HEAPHY (AU)
DARE, Michael (AU)
QIAN, Junbo (AU)

74

Mandataire : SCP AKKUM, AKKUM & Associates,
Quartier Mballa II, Dragages,
B.P. 4966, YAOUNDE (CM).

54

Titre : Hammerless pin assembly.

57

Abrégé :

A pinned rigging component providing relative movement for a connected rigging component includes an integrated hammerless lock. An integral lock is retained in the body of the rigging component and releasably retains the pin in the component. The lock is recessed in the body and is not subject to significant wear during operation.

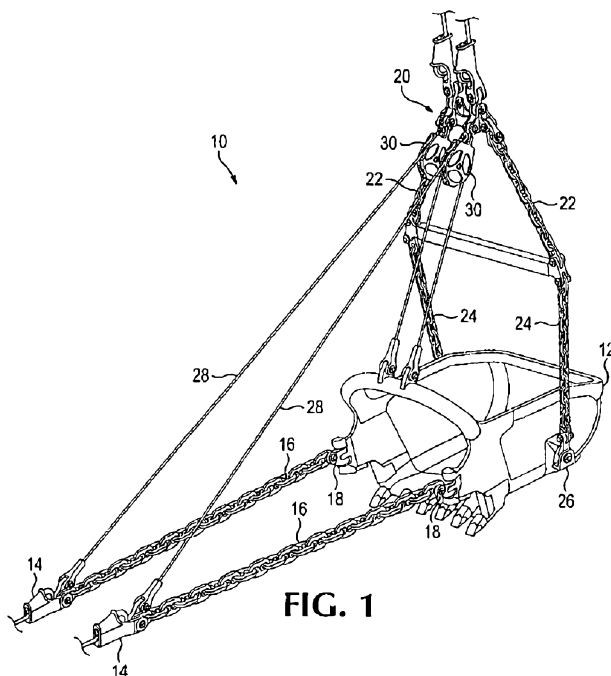

FIG. 1

HAMMERLESS PIN ASSEMBLY

Field of the Invention

[1] The present invention relates to pinned connections used to join components that rotate about the pin axis relative to each other for earth working applications.

Background of the Invention

[2] Pins are commonly used to join components that rotate in relation to each other. A pin passes through openings in each of the components and is retained by mechanical means such as friction or by use of a retainer(s) on the pin or component. The openings and the pin surface form bearing surfaces as the component pivots.

[3] Mining equipment uses pins extensively to join very large components used in highly abrasive environments. Figure 1 shows a dragline bucket system used in open pit mining operations with rigging for moving the bucket. The rigging handles extreme loads in pulling the bucket to collect earthen material and lifting the filled bucket. The bucket 12 is pulled forward by drag chain 16 attached to hitch 18 on the front of the bucket by drag links 14. Teeth on the lower lip engage and initially gather the earthen materials into the bucket.

[4] Once filled, the bucket is lifted by cables connected to an upper hoist rigging assembly 20 connected to the bucket by upper hoist chains 22 and lower hoist chains 24 to trunnions 26 of the bucket. Once lifted off the ground the bucket can be repositioned to a dump site for spoiling material. When tension is released on the drag link, the dump cable 28 passing through the dump block 30 releases allowing the bucket to rotate about the trunnion point well back of the center of gravity and tip forward so that the earthen materials are dumped from the bucket. The connections between the cables, chains and the bucket include one or several pins to secure the components to adjacent components.

[5] In aggressive environments, the pins and the components wear quickly and require frequent replacement. Dirt, rocks, and other debris abrade the dragline bucket and the rigging as they contact or slide against the ground. Connections between the various elements also experience wear in areas where surfaces of the elements bear against each other and are subjected to tensile, compressive, or various other forces. Following a period of use, therefore, portions of the dragline excavating system are subjected to maintenance to permit worn or otherwise damaged elements to be inspected, repaired, or replaced.



[6] Rigging components for dragline mining vary in size and weight. The dump block can weigh several thousand pounds, and the pins and links of the chain can each weigh several hundred pounds. Replacing the pins can require heavy lifting equipment for each component and each component has to be aligned for the pin to be removed or installed. The installation operation can be hazardous for the installers. Cutting away and reattaching retention plates that often retain the pins can be time consuming and expensive.

[7] A pin assembly that can be installed with less handling and processing while incurring fewer hazards to the operators would be advantageous.

10

SUMMARY

[8] Pinned connections are used in a wide variety of excavating equipment, but may be used in a variety of earth working environments, including a wide range of mining, dredging, forestry, and construction equipment as well. The pin assembly of the present invention reduces the handling of the components, the time required for installing and removing pins from equipment, and the downtime required for maintenance.

[9] In one example, pinned connections or pin assemblies are used in mining. Mining equipment operates in extremely abrasive environments with dust and debris that penetrate every crevice. Even components that are not intended to contact the earthen materials are affected by the sand and dust generated during processing.

[10] In an alternative embodiment, a pin assembly component for earth working equipment comprises a body including at least one opening into which a pin is received to couple the pin assembly component to at least one other part. A hole extends transverse to and communicating with the opening. A hammerless lock is secured in the hole. The lock is adjustable to alternatively retain the pin in the opening and release the pin to permit installation and removal of the pin from the opening. The lock is retained to the body in the hole when holding the pin and when releasing the pin.

[11] In an alternative embodiment, a pin assembly component for earth working equipment comprises a body including a pair of arms each of which includes an opening where the openings are aligned with each other to define a passage for receiving a pin to couple the pin assembly component to another part. A hole extends transverse to the passage communicating with one of said openings. A lock including a threaded collar is secured within the hole. A threaded lock pin is threadedly received

35



into the collar such that the pin can be advanced to contact the pin to retain the pin in the openings and retracted to permit installation and removal of the pin.

[12] In an alternative embodiment, a pin assembly component for earthworking equipment comprises first and second arms each with an opening where the openings
5 are aligned. A hole defined by a wall extends through the arm from an exterior arm surface to the opening to receive a lock to hold a pin in the openings, the wall defining the hole including a retaining structure between the arm surface and the opening. The retaining structure has an upper shoulder and a lower shoulder for contacting corresponding bearing surfaces on the lock to positively hold the lock in the hole
10 against inward and outward forces on the lock.

[13] In an alternative embodiment, a pin assembly component for use with excavating equipment comprises an arm with an aperture and a hole defined by a wall extending through the arm and opening in both a surface of the arm and the aperture
15 to receive a lock to hold a pin in the aperture. The wall defining the hole includes a retaining structure between the arm surface and the aperture. The retaining structure has an upper bearing surface and a lower bearing surface for contacting corresponding bearing surfaces on the lock to positively hold the lock in the hole against inward and outward forces on the lock. The wall defines a slot adjacent the retaining structure and extending along the length of the hole from the arm surface
20 toward the aperture to permit a lock component of a unified construction to be installed in the hole and contact the upper shoulder and the lower shoulder.

[14] In an alternative embodiment, a pin assembly component for earthworking equipment comprises a body with a pair of extending arms, each arm having an opening, the openings being aligned to receive a pin. A hole in one arm extends from
25 an exterior arm surface to the opening with a lock installed in the hole. The lock includes a one-piece mounting component mechanically secured in the hole to resist movement of the mounting component in both inward and outward directions in the hole. The lock also includes a holding component movable in the mounting component between a release position where the pin can be received in the openings
30 and removed from the openings of the coupling body and a locked position where the pin is secured to the coupling body.

[15] In an alternative embodiment, a pin assembly component for earthworking equipment comprises a structure for receiving a pin and a hole defined by a wall. The wall includes a retaining structure having an upper shoulder and a lower shoulder. A
35 collar in the hole includes lugs to straddle the retaining structure and contact the upper



and lower shoulders to resist movement of the collar in both inward and outward direction in the hole, and a threaded opening. A threaded lock pin is received in the threaded opening for movement between a release position where the pin can be installed in and removed from the structure, and a locked position where the pin is
5 secured to the structure.

[16] The pin assembly reduces the risk to the operator installing the pin to the components, provides for reduced wear of the components during operation, and limits wear.

[17] In one inventive concept of the present invention, the lock is integral to the component and remains in a passage of the component during removal and
10 installation of the pin.

[18] In another inventive concept of the present invention, the body includes an aperture for receiving a pin and a hole through the body opening to the aperture. The hole retains an integrated lock that moves between a locked position extending into the pin opening and an unlocked position retracted from the pin opening.
15

[19] In another inventive concept of the present invention, a component incorporates a lock that extends from a hole into a recess of a pin to retain the pin in the component. The lock is retained in the body of the component in both the extended and retracted positions.

[20] In another inventive concept of the present invention, a pin is secured by a lock that includes a detent to positively secure the lock in a retained position where the pin is held in the assembly and a release position where the pin can be installed or removed from the assembly.
20

[21] In another inventive concept of the present invention, a pin is secured by a lock that includes a threaded collar mechanically fixed to one component and a threaded lock pin received within the collar and movable between a retained position and a release position.
25

[22] The different inventive concepts can be used independently without the other inventive concepts in a pin assembly to achieve one or more of the various
30 benefits of the present invention.

List of Figures

[23] Figure 1 is a perspective view of rigging for a dragline bucket.

[24] Figure 2 is a perspective exploded view of a rigging wear component as a y-link with a pin received by the link.
35



- [25] Figure 3 is a detail view of a lock of Figure 2.
- [26] Figure 4 is a top view of the link of Fig. 2.
- [27] Figure 5 is a side view of the link of Fig. 2.
- [28] Figure 6 is a perspective cross section view of the lock assembly.
- 5 [29] Figure 7 is a perspective exploded view of the lock.
- [30] Figure 8 is a cross-sectional view from section 8-8 in Fig. 4 of the lock installed in the link.
- [31] Figure 9 is a partial perspective view of the lock passage in the arm of the link.
- 10 [32] Figure 10 is a partial perspective view of the lock passage of Fig. 9 with the mounting component of the lock partially installed.
- [33] Figure 11 is a partial perspective view of the lock passage of Fig. 9 with the mounting component installed in the link.
- [34] Figure 12 is an exploded perspective view of a retainer, the lock and lock
15 passage.

Detailed Description of the Preferred Embodiments of the Invention

- [35] Mining operations require large and heavy rigging to handle drag buckets and other equipment used in open pit mines. The rigging uses pins extensively to hold
20 many of the components together. In operation, these pins are exposed to abrasive particles that infiltrate any gap in the assemblies. These particles, combined with the extreme loads seen by the pins, limit the service life of the components by eroding exposed and mating surfaces until the components are not serviceable. Refurbishing the rigging requires handling parts weighing tons and aligning combinations of parts to
25 accommodate the assembly and disassembly of the pins from the components. Handling these large parts can be dangerous for the operators and can take the equipment out of service for long periods. The mining application is used as an example to describe preferred embodiments of the invention. Pin assembly embodiments of the invention are usable in other earth working operations.
- 30 [36] A pin assembly that provides more efficient installation and extraction of the pin is generally shown in Figures 2-12. A Y-link is a common rigging wear component for connecting different components as shown in Fig. 2 and is used herein as an example. Y-link 100 includes a body with arms 100A and 100B extending in the same general direction. Each arm has an opening or aperture 106 and 110.. In this example,
35 another rigging component is received between arms 100A and 100B. An opening of

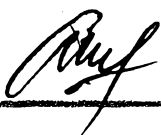

another rigging component to be coupled to link 100 is generally aligned with and between openings 106 and 110. The aligned openings accept a pin 102 with a shaft or body 102B and a head 104 to join the components. The pin head 104 as shown is square and is received in recess 106A, though other shapes are possible. Head 104 can be flush or recessed from the outer face of the arm when installed. Pin 104 with a square head received in a recess is fixed and does not rotate freely in the openings during operation.

[37] Link 100 includes an opening 112 for connecting another adjacent rigging component. Arm 100B includes a lock passage 108 extending generally transversely to the axis of the aligned openings 106, 110. The axis of the pin 102 aligns with this opening axis when inserted. Lock passage 108 includes retention features and the passage receives and retains lock 200.

[38] Lock 200 is generally shown in Figures 6-12. Lock 200 is integrally installed in lock passage 108 so that it is retained in both the released position and the locked position. This allows the pin 102 to be maintained or replaced without handling the lock separately from the link. The rigging wear component can be disassembled and assembled without the lock being dropped or lost. This can significantly improve maintenance procedures and reduce downtime for excavating equipment. The inventive assembly reduces the need for separate handling of the lock. Moreover, searching for a dropped component at night can be difficult and can put personnel in a hazardous situation underneath heavy components.

[39] Lock 200 is retained in lock passage 108 and when engaged to the pin 102 restrains axial movement of the pin in openings 106 and 110 to prevent loss of the pin. The lock includes a lock pin 220 received in a collar 222 mechanically retained in the link 100. The collar contains features supportive of integrated shipment, load transmission, lock installation and lock removal. The lock pin 220 and collar are preferably threaded so that pin 220 helically advances through the center of the collar 222 between two low energy positions created by an elastomer backed latching mechanism. The first position, (e.g., with a 1/2 turn of thread engaged between the collar and the pin) is a release position where the pin is preferably retained during shipment, storage, installation and removal. The lock pin 220 advances into the second low energy position after rotating (e.g., 2 1/2 turns) ending preferably in a hard stop signaling that the system is locked. When the link pin 102 requires removal, the lock pin 220 is rotated counter-clockwise to retract the lock pin. In a preferred construction, pin 102 includes a recess 102A in pin shaft 102B that receives at least a



portion of the lock pin to hold the pin in place, and from which the lock pin is retracted to allow the pin 102 to slide free from openings 106 and 110 in link 100. Other arrangements to facilitate effective engagement of the lock pin and the pin could be used.

5 [40] Lock 200 includes a mounting component or collar 222 and a retaining component or lock pin 220 (Figs. 6, 7, 8 and 12). Collar 222 fits in passage 108 of link 100 and includes a bore or opening 223 with threads 258 for receiving lock pin 220 with matching threads 254. A retainer 224, preferably in the form of a retaining clip, is inserted in passage 108 with collar 222 to prevent disengagement of the collar
10 222 from link 100. Preferably, retainer 224 is inserted during manufacture of link 100 so that lock 200 is integrally coupled with link 100 (i.e., to define a link that integrally includes a lock) for shipping, storage, installation and/or use of the link. Such a construction reduces inventory and storage needs, eliminates dropping the lock during installation (which can be particularly problematic at night), ensures the proper lock is
15 always used, and eases the installation of the link. Although the lock is preferably always retained in the component, retainer 224 could be made to be removable to permit removal at any time so as to effect removal of lock 200.

[41] Collar 222 has a cylindrical body 225 with lugs 236, 237 that project outward to contact and bear against bearing surfaces of retaining structure 202 to hold
20 lock 200 in place in link 100. To install collar 222, body 225 is inserted into passage 108 from within opening 106 such that lugs 236, 237 are slid along passage 108. Collar 222 is preferably translated into passage 108 until flange 241 is received in passage 108. Collar 222 is then rotated until lugs 236, 237 straddle retaining structure 202. The rotation of collar 222 is preferably approximately 30 degrees so
25 that lugs 236, 237 move into upper reliefs 204, 206. The engagement of lugs 236, 237 against both sides of retaining structure 202 hold collar 222 in passage 108 even under load during digging. Further, the cooperation of outer lug 236 and flange 241 provide a resistive couple against cantilever loads applied to lock pin 220 during use.

[42] Once collar 222 is in place, a retainer or clip 224 is inserted into passage
30 108 from outside link 100. Preferably, retainer 224 is snap-fit into a slot 210 along passage 108, thereby preventing rotation of collar 222 so that lugs 236, 237 are retained in reliefs 204, 206. Retainer 224 is preferably formed of sheet steel with a bent tab 242 that snaps into a receiving notch 244 on an outer surface 246 of collar 222 to retain retainer 224 in link 100. The retainer allows collar 222 to be locked in
35 link 100 for secure storage, shipping, installation and/or use, and thereby define an



integral part of link 100. A flange 267 is preferably provided to abut lug 236 and prevent over-insertion of the retainer.

[43] The engagement of lugs 236, 237 against retaining structure 202 mechanically hold collar 222 in passage 108 and effectively prevent inward and outward movement during shipping, storage, installation and/or use of link 100 (Figs. 9-11). A mechanical attachment is preferred because the hard, low alloy steel commonly used to manufacture links for earth working equipment generally lacks sufficient weldability. Collar 222 is preferably a single unit (one piece or assembled as a unit), and preferably a one piece construction for strength and simplicity. Retainer 224 is preferably formed of sheet steel as it does not resist the heavy loads applied during operations. Retainer 224 is used only to prevent undesired rotation of collar 222 in passage 108 so as to prevent release of lock 200 from link 100. Nevertheless, other means for securing collar 222 in passage 108 could be used.

[44] Lock pin 220 includes a head 247 and a shank 249. Shank 249 is formed with threads 254 along at least a portion of its length from head 247. Pin end 230 is preferably unthreaded for receipt into a hole 102A in pin 102. Lock pin 220 is preferably installed into collar 222 from outside link 100 so that pin end 230 is the leading end and pin threads 254 engage collar threads 258. A hex socket (or other tool-engaging formation) 248 is formed in (or on) head 247, at the trailing end, for receipt of a tool to turn lock pin 220 in collar 222.

[45] Locks 200 are preferably used to secure pin 102 to link 100. In the preferred construction, one lock 200 holds pin 102 to link 100. Alternatively, two locks could be used to secure the pin to the wear component. Alternatively, the lock could engage the end surface of the pin to restrain the axial movement of the pin in only one axial direction. The other end could be blocked by conventional means or a second inventive lock. The locking system can retain a floating pin that is free to move in the openings. Pin 102 can be a cylindrical pin without a head. An annular recess can be machined near the end of the cylindrical pin that accepts the pin of the lock and limits movement of the pin axially in the opening but allows the pin to rotate axially. Other configurations can be used as well. One example of a lock 200 is illustrated here. The lock could have a wide variety of constructions that perform a similar function of limiting movement of the pin.

[46] A Y-link is depicted here as an example only for the purpose of illustration. The inventive concept can be applied to a range of pinned components in addition to a Y-link. Pin102 preferably includes a recess 102A that receives a portion of lock 200 to



limit axial movement of pin 102 in the openings during operation. The recess to receive a portion of the lock can be located in the shaft 102B of the pin or in the head 104.

[47] In one preferred embodiment, threaded lock pin 220 includes a biased latching tooth or detent 252, biased to protrude beyond the surrounding thread 254. A corresponding outer pocket or recess 256 is formed in the thread 258 of collar 222 to receive detent 252, so that threaded lock pin 220 latches into a specific position relative to collar 222 when latching detent 252 aligns and connects with outer pocket 256. The engagement of latching detent 252 in outer pocket 256 holds threaded lock pin 220 in a release position relative to collar 222, which holds lock pin 220 with sufficient clearance outside of recess 102A on pin 104. The lock pin is preferably shipped and stored in the release position so that link 100 is ready to install. Preferably, latching detent 252 is located at the start of the thread on threaded lock pin 220. Outer pocket 256 is located preferably approximately 1/2 rotation from the start of the thread on collar 222. As a result, lock pin 220 will latch into shipping position after approximately 1/2 turn of lock pin 220 within collar 222. Other arrangements are, of course, possible. The detent could alternatively be supported by the collar and fit into a recess in the locking pin.

[48] Further application of torque to lock pin 220 will squeeze latching detent 252 out of outer pocket 256. An inner pocket or recess 260 is formed at the inner end of the thread of collar 222. When lock pin 220 is installed into collar 222, it is preferably rotated 1/2 turn to the release position for shipping, storage and/or installation of link 100. Lock pin 220 is then preferably rotated 2 1/2 turns until pin end 230 is fully received into recess 102A in the locked or service position. More or fewer rotations of threaded lock pin 220 may be needed, depending on the pitch of the threads, and on whether more than one start is provided for the threads. The use of a particularly coarse thread requiring, e.g., only three full rotations of threaded lock pin 220 for full locking of a pin 102 to link 100 has been found to be easy to use in field conditions, and reliable for use under the extreme conditions of excavation. Furthermore, the use of a coarse helical thread is better in installations where the lock assembly will become surrounded by compacted fines during use.

[49] Preferably, lock 200 is recessed in passage 108 so that it remains shielded from moving earthen material over the life of the link. Earthen material will tend to accumulate in passage 108 above lock 200 and protect the lock from undue wear



even as link 100 wears. Further, the lock is generally centrally located in link 100 with pin end 230 located at or proximate the center of recess 102A in the locked position.

[50] Pin 102 may be released using a ratchet tool or other tool to unscrew lock pin 220 from collar 222. While lock pin 220 can be removed from collar 222, it need
5 only be backed up to the release position. Pin 102 can then be removed from link 100. The torque of unscrewing lock pin 220 may exert substantial torsion loads on collar 222, which loads are resisted by engagement with retaining structure 202, providing a strong and reliable stop for lugs 236 and 237.

[51] The mounting component or collar 222 of lock 200 defines a threaded bore
10 223 for receiving the threaded securing lock pin 220 that is used to releasably hold pin 102 to link 100. The separate mounting component 222 can be easily machined or otherwise formed with threads, and secured within the link for less expense and higher quality threads as compared to forming the threads directly in the link. The steel used for link 100 is very hard and it is difficult to cast or otherwise form screw
15 threads into passage 108 for the intended locking operation. The relatively large size of link 100 also makes it more difficult to cast or otherwise form screw threads in passage 108. The mounting component 222 can be mechanically held within the passage in the link to resist axial movement in either direction (i.e., that is in and out of passage 108) during use so as to better resist unintended loss of the lock during
20 shipping, storage, installation and use. On account of the hard steel typically used for link 100, mounting component 222 could not be easily welded into passage 108. Nevertheless, threads or partial threads could be formed in channel 108 or the collar could be welded in channel 108.

[52] The use of a lock in accordance with the present invention provides many
25 benefits: (i) a lock integrated into a link so that the lock ships and stores in a ready to install position for less inventory and easier installation; (ii) a lock that requires only common drive tools such as a hex tool or ratchet driver for operation, and requires no hammer; (iii) a new lock provided with each wear part; (iv) a lock that is positioned for easy access; (v) a lock with a simple, intuitive and commonly understood operation;
30 (vi) a lock integration system built around simple castable feature where the integration supports high loads, requires no special tools or adhesives and creates a permanent assembly.

[53] While the application has described the invention primarily in terms of pins
35 for joining components, the invention could also be employed in other applications where pins are used. It is believed that the disclosure set forth herein encompasses



multiple distinct inventions with independent utility. While a lock for a pin has been disclosed in its preferred form, the specific embodiments thereof as disclosed and illustrated herein are not to be considered in a limiting sense as numerous variations are possible. While different configurations have been described to achieve a specific functionality, combinations of these configurations may be used and still fall within the scope of this disclosure. Where the description recites "a" or "a first" element or the equivalent thereof, such description includes one or more such elements, neither requiring nor excluding two or more such elements. Further, ordinal indicators, such as first, second or third, for identified elements are used to distinguish between the elements, and do not indicate a required or limited number of such elements, and do not indicate a particular position or order of such elements unless otherwise specifically stated.

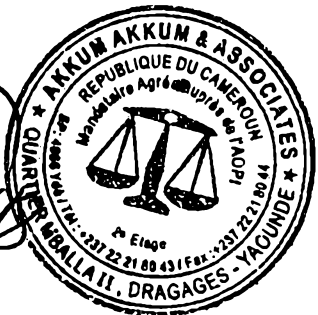
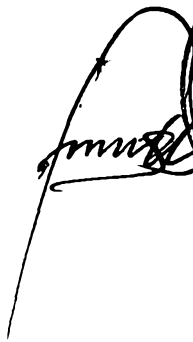

27/08/2015

Claims

1. A pin assembly component for earth working equipment comprising:
 - a body including at least one opening into which a pin is received to couple the pin assembly component to at least one other part, and a hole extending transverse to and communicating with the opening; and
 - a hammerless lock secured in the hole and adjustable to alternatively retain the pin in the opening and release the pin to permit installation and removal of the pin from the opening, the lock being retained to the body in the hole when holding the pin and when releasing the pin.
2. A pin assembly component in accordance with claim 1 wherein the lock defines a pre- established hold position and pre-established release position and stops to releasably hold the lock in both positions.
3. A pin assembly component in accordance with claim 2 wherein the stops are defined by a biased latch received into latch openings.
4. A pin assembly component in accordance with any of the previous claims wherein the lock includes a threaded collar and a threaded lock pin threadedly received into the collar.
5. A pin assembly component in accordance with claim 4 wherein one of the collar and lock pin include at least one biased latch and the other of the collar and lock pin include at least one latch opening to receive the latch to releasably retain the lock pin in each of the hold and release positions.
6. A pin assembly component in accordance with any of the previous claims wherein the lock includes a threaded collar and a threaded lock pin threadedly received into the collar.
7. A pin assembly component in accordance with any of the previous claims wherein the body includes a pair of arms each of which includes one of said openings where the openings are aligned with each other.



8. A pin assembly component for earth working equipment comprising:

a body including a pair of arms each of which includes an opening where the openings are aligned with each other to define a passage for receiving a pin to couple the pin assembly component to another part, and a hole extending
5 transverse to the passage and communicating with one of said openings; and

a lock including a threaded collar secured within the hole and threaded lock pin threadedly received into the collar such that the pin can be advanced to contact the pin to retain the pin in the openings and retracted to permit installation and removal of the pin.

10 9. A pin assembly component in accordance with claim 8 wherein one of the collar and lock pin include at least one biased latch and the other of the collar and lock pin include at least one latch opening to receive the latch to releasably retain the lock pin when advanced and when retracted.

15 10. A pin assembly component for earthworking equipment comprising first and second arms each with an opening where the openings are aligned, a hole defined by a wall extending through the arm from an exterior arm surface to the opening to receive a lock to hold a pin in the openings, the wall defining the hole including a retaining structure between the arm surface and the opening, and the retaining structure having an upper shoulder and a lower shoulder for contacting corresponding
20 bearing surfaces on the lock to positively hold the lock in the hole against inward and outward forces on the lock.

25 11. A pin assembly component in accordance with claim 10 wherein the wall defining the hole defines a passage adjacent the retaining structure and extending along the length of the hole from the arm surface toward the opening to permit a lock component of a unified construction to be installed in the hole and contact the upper shoulder and the lower shoulder.

30 12. A pin assembly component in accordance with claim 10 or 11 wherein the retaining structure is a continuation of the wall defining the hole surrounded on three sides by a relief in the wall to receive a lock component into the hole to contact the upper and lower shoulders.

13. A pin assembly component for use with excavating equipment comprising an arm with an aperture and a hole defined by a wall extending through the arm and



opening in both a surface of the arm and the aperture to receive a lock to hold a pin in the aperture, the wall defining the hole including a retaining structure between the arm surface and the aperture, the retaining structure having an upper bearing surface and a lower bearing surface for contacting corresponding bearing surfaces on the lock to positively hold the lock in the hole against inward and outward forces on the lock, and the wall defining a slot adjacent the retaining structure and extending along the length of the hole from the arm surface toward the aperture to permit a lock component of a unified construction to be installed in the hole and contact the upper shoulder and the lower shoulder.

10 14. A pin assembly component in accordance with claim 13 wherein the assembly includes two arms with aligned apertures.

15 15. A pin assembly component in accordance with claim 13 or 14 wherein the retaining structure is a continuation of the wall defining the hole surrounded by a relief in the wall above and below the retaining structure and the slot on an end of the retaining structure, and the relief and slot are interconnected to receive a lock component into the hole to contact the upper and lower bearing surfaces.

16. A pin assembly component for earthworking equipment comprising:

20 a body with a pair of extending arms, each arm having an opening, the openings being aligned to receive a pin, and a hole in one arm extending from an exterior arm surface to the opening; and

25 a lock installed in the hole, the lock including a one-piece mounting component mechanically secured in the hole to resist movement of the mounting component in both inward and outward directions in the hole, and a holding component movable in the mounting component between a release position where the pin can be received in the openings and removed from the openings of the coupling body and a locked position where the pin is secured to the coupling body.

30 17. A pin assembly component in accordance with claim 16 wherein the mounting component and the holding component have complementary threads to effect movement of the holding component between the release and locked positions.

18. A pin assembly component in accordance with claim 16 or 17 wherein the hole in the coupling body includes a retaining structure with upper and lower oppositely-



facing bearing surfaces, and the mounting component includes complementary bearing surfaces to contact the upper bearing surface and the lower bearing surface on the retaining structure.

19. A pin assembly component for earthworking equipment comprising:

- 5 a structure for receiving a pin,
a hole defined by a wall, the wall including a retaining structure having an upper shoulder and a lower shoulder,
a collar in the hole including lugs to straddle the retaining structure and contact the upper and lower shoulders to resist movement of the collar in both
10 inward and outward direction in the hole, and a threaded opening, and
a threaded lock pin received in the threaded opening for movement between a release position where the pin can be installed in and removed from the structure, and a locked position where the pin is secured to the structure.

20. A pin assembly component for earthworking equipment comprising:

- 15 a structure for receiving a pin,
a hole defined by a wall, the wall including a retaining structure having an upper shoulder and a lower shoulder,
a collar in the hole including lugs to straddle the retaining structure and contact the upper and lower shoulders to resist movement of the collar in both
20 inward and outward direction in the hole, and a threaded opening, and
a threaded lock pin received in the threaded opening for movement between a release position where the pin can be installed in and removed from the structure, and a locked position where the pin is secured to the structure.

21. A pin assembly according to claim 20 wherein the wall defining the hole in the
25 wear member includes a retaining structure between the component surface and the aperture, and the retaining structure having an upper shoulder and a lower shoulder for contacting corresponding bearing surfaces on the lock to positively hold the lock in the hole against inward and outward forces on the lock.



Abstract

A pinned rigging component providing relative movement for a connected rigging component includes an integrated hammerless lock. An integral lock is retained in the body of the rigging component and releasably retains the pin in the component. The lock is recessed in the body and is not subject to significant wear during operation.

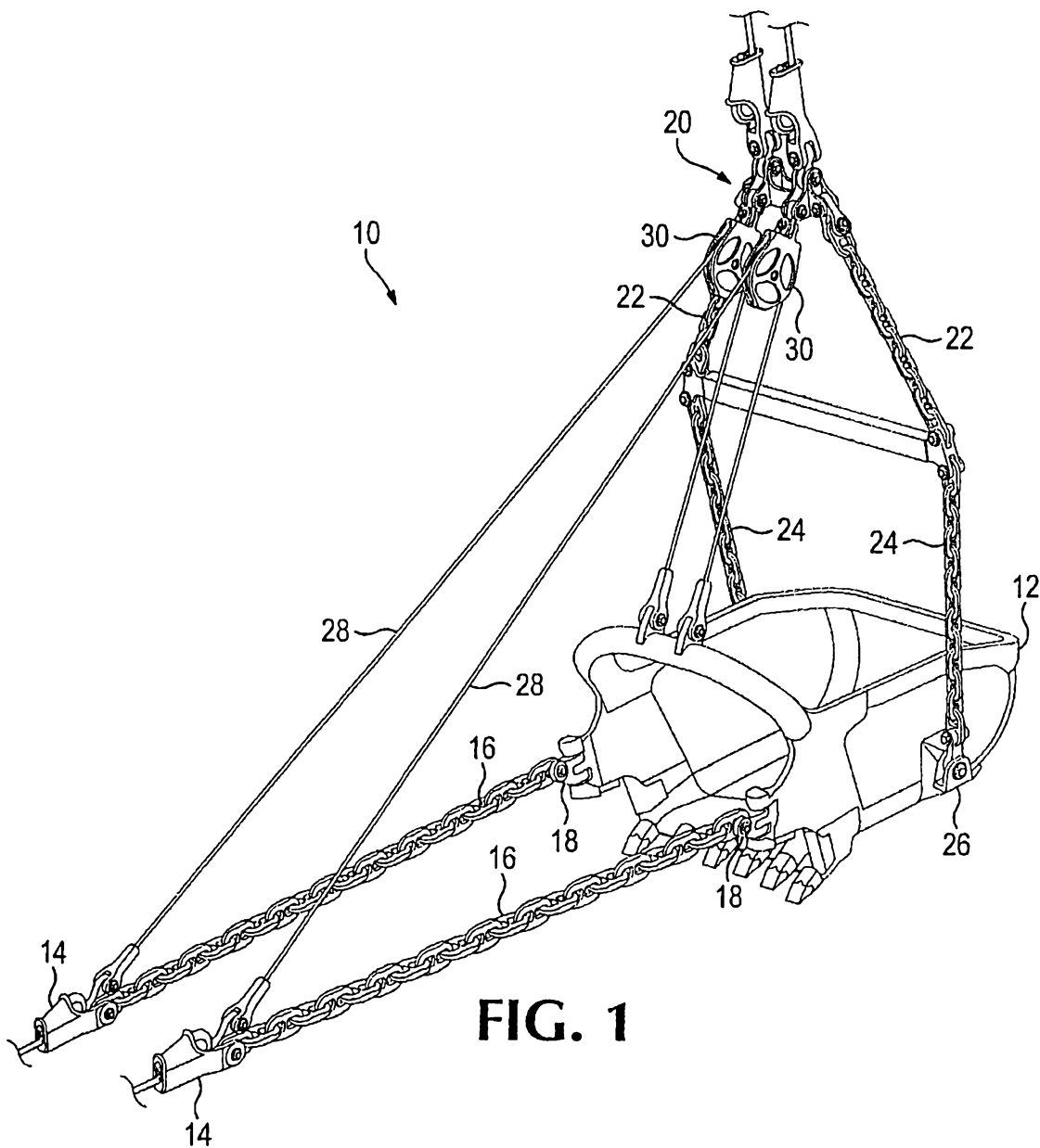

FIG. 1

2/7

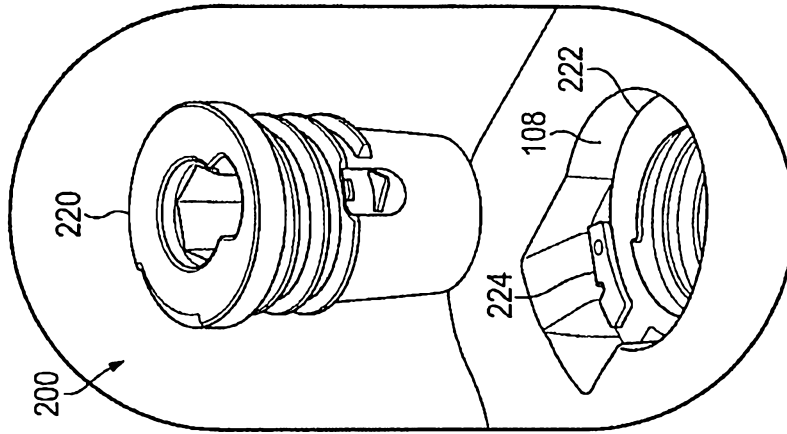

FIG. 3

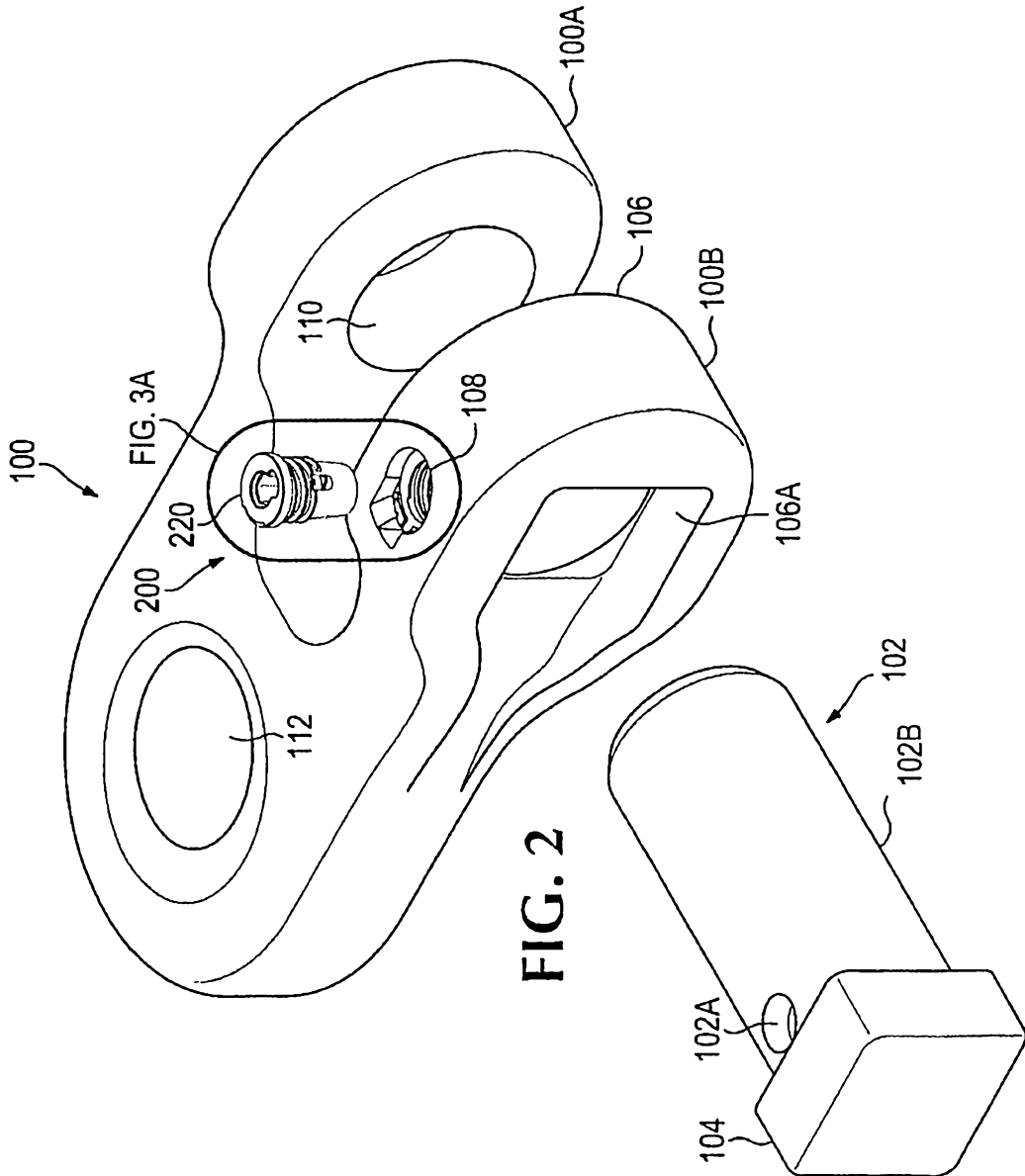

FIG. 2

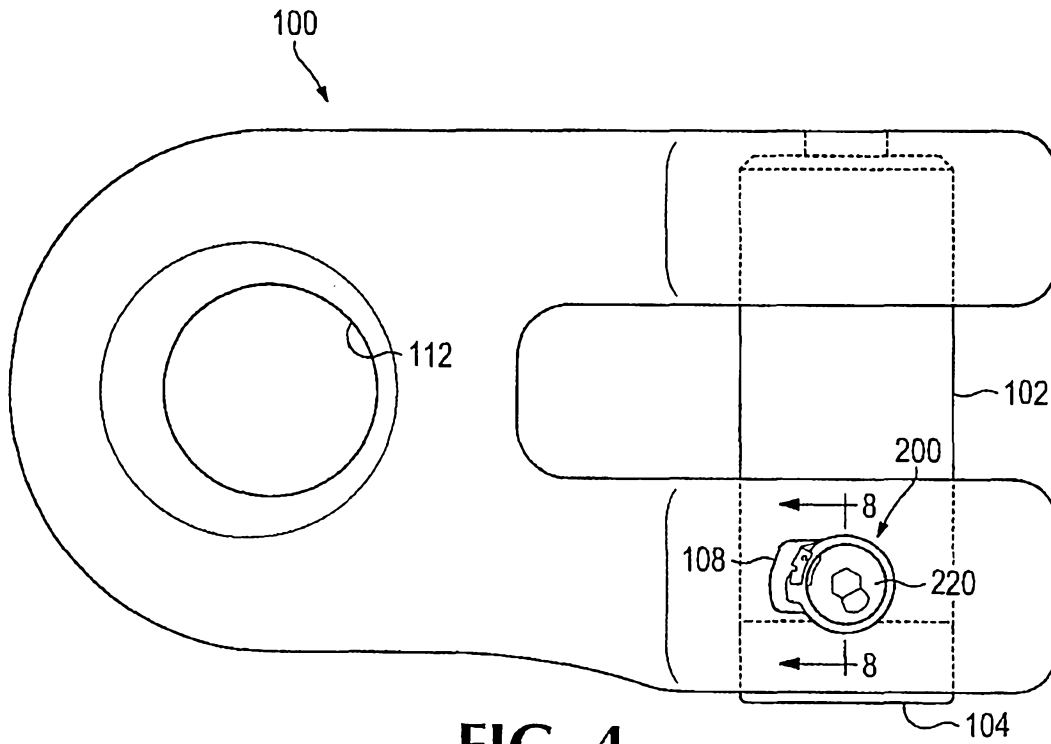

FIG. 4

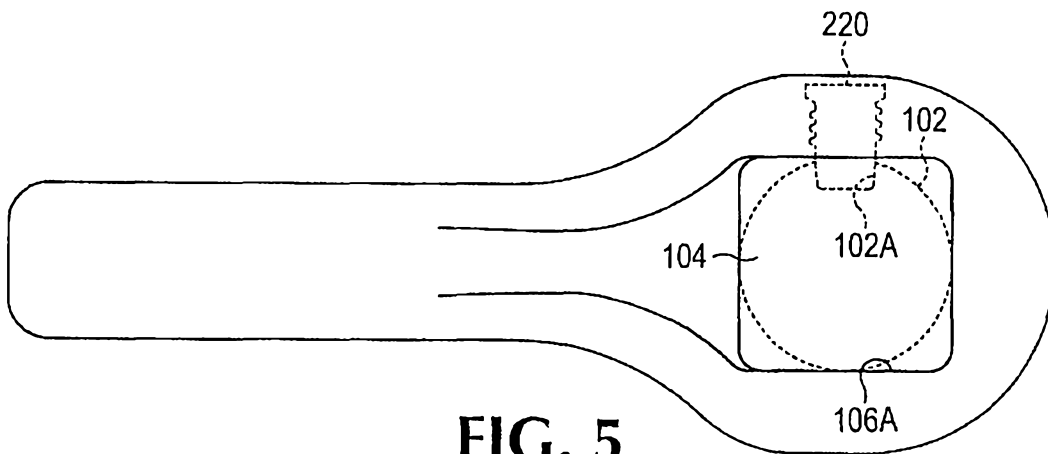

FIG. 5

4/7

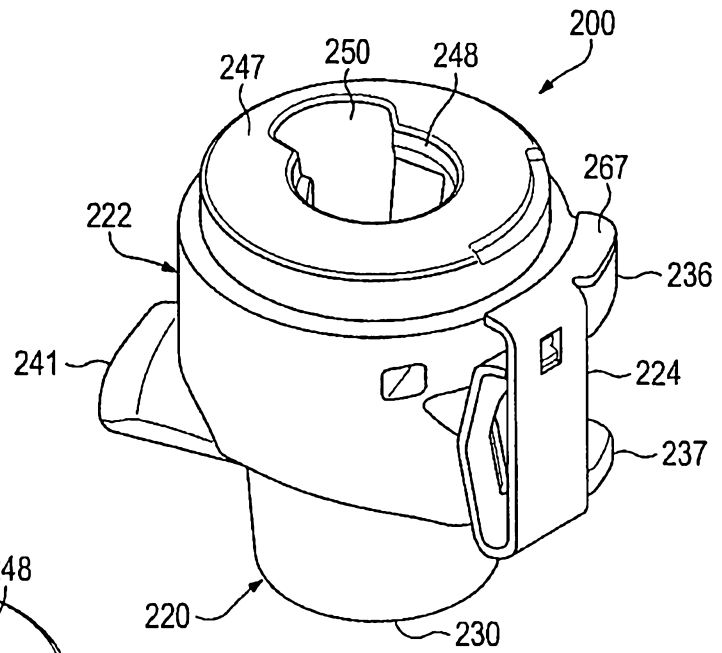

FIG. 6

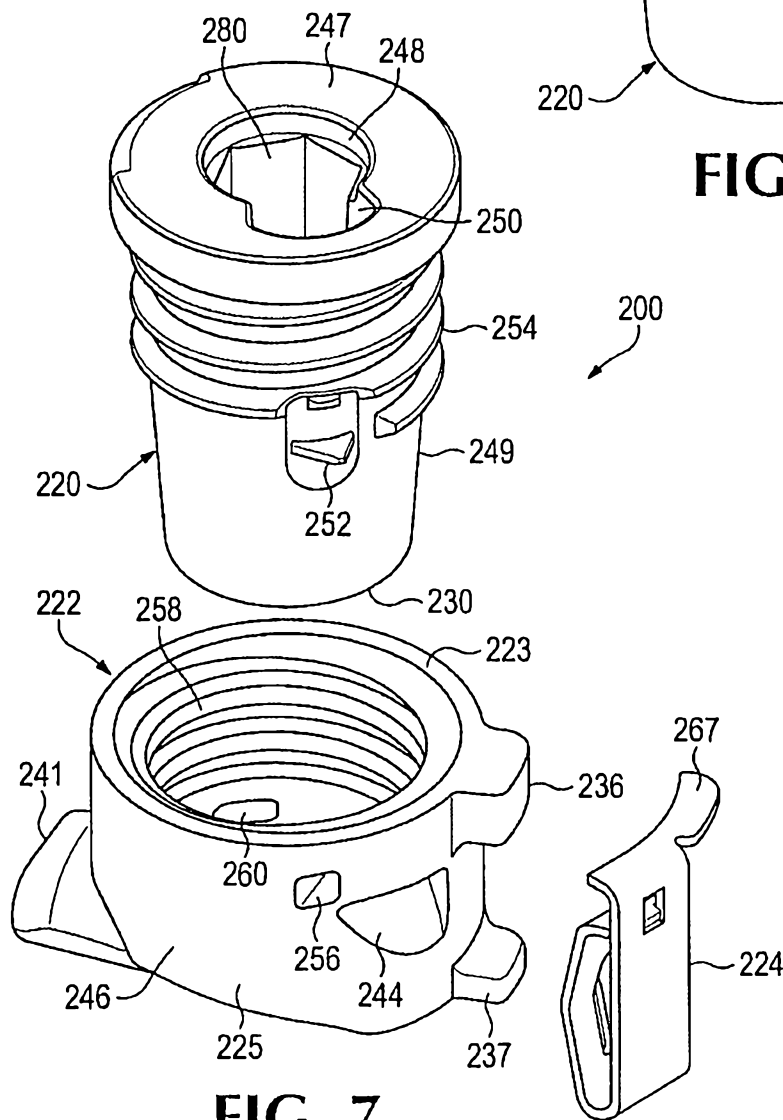

FIG. 7

5/7

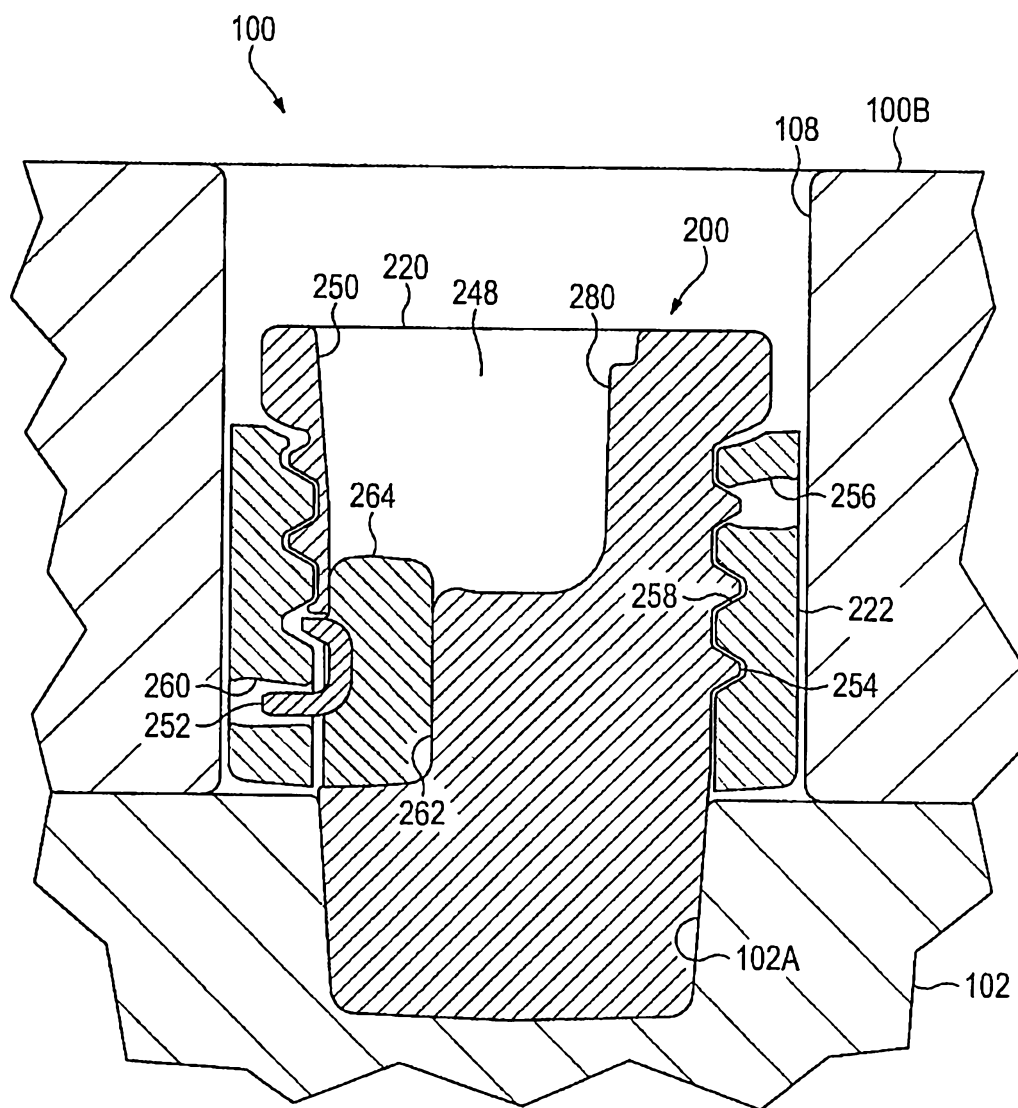

FIG. 8

6/7

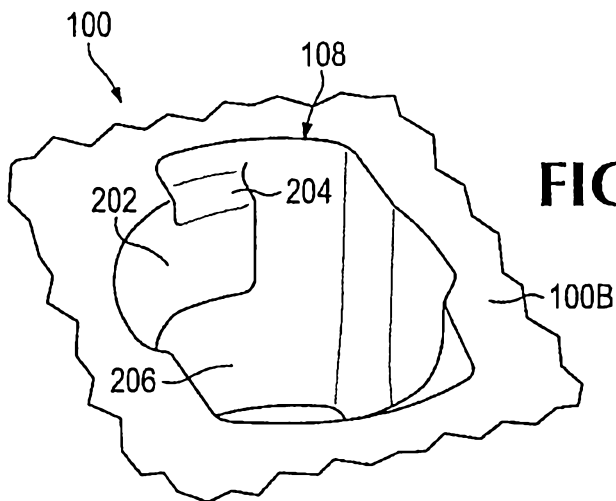

FIG. 9

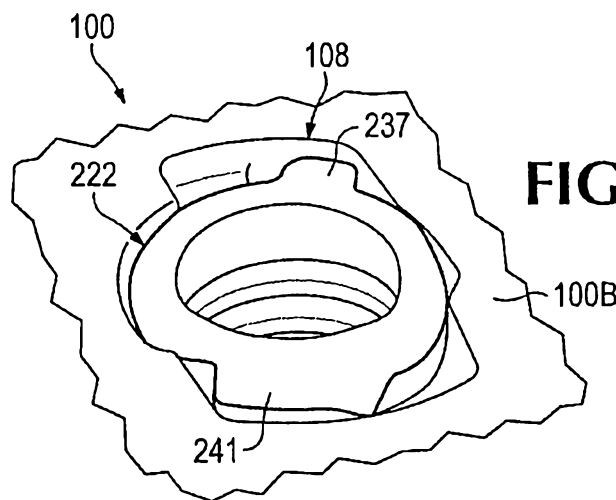

FIG. 10

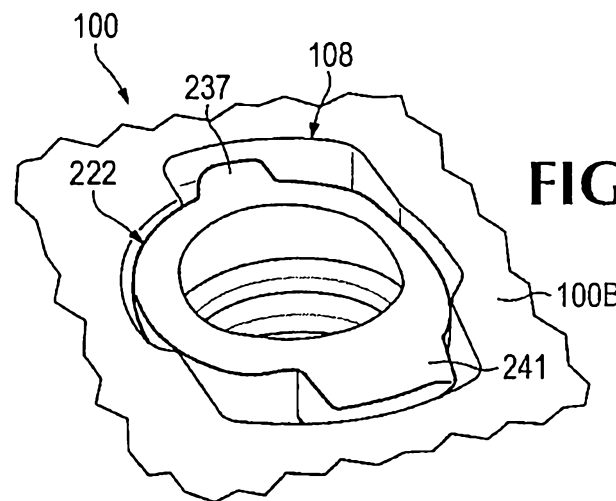

FIG. 11

717

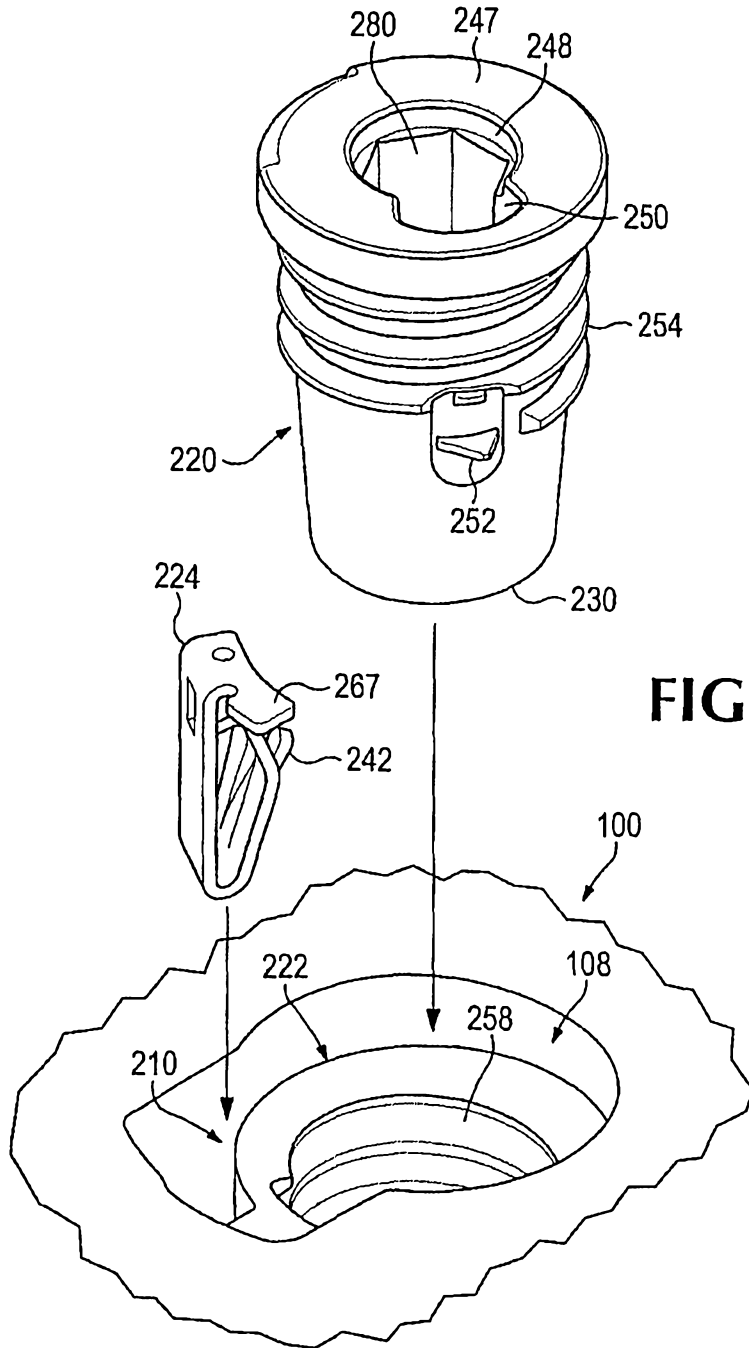

FIG. 12