

(No Model.)

A. TROMBLEE.  
ADJUSTABLE ANGLE SHEAVE.

No. 315,090.

Patented Apr. 7, 1885.

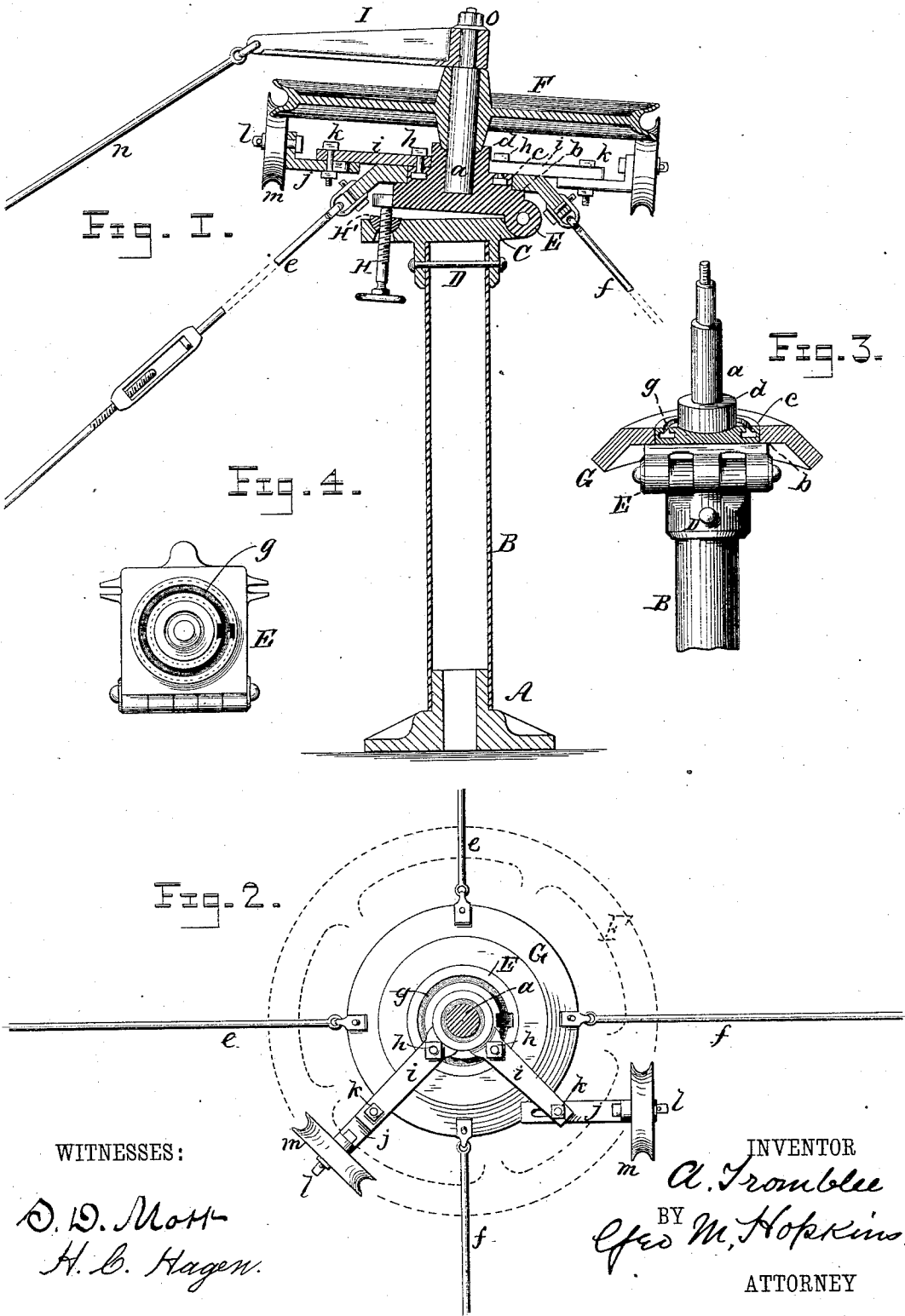

WITNESSES:

D. D. Mott  
H. C. Hagen.

INVENTOR

A. Tromblee  
BY  
Geo M. Hopkins

ATTORNEY

# UNITED STATES PATENT OFFICE.

ANDREW TROMBLEE, OF PORT HENRY, NEW YORK.

## ADJUSTABLE ANGLE-SHEAVE.

SPECIFICATION forming part of Letters Patent No. 315,090, dated April 7, 1885.

Application filed October 24, 1884. (No model.)

*To all whom it may concern:*

Be it known that I, ANDREW TROMBLEE, of Port Henry, in the county of Essex and State of New York, have invented a new and Improved Adjustable Angle-Sheave for Supporting and Guiding Bands and Ropes Used in Transmitting Power, of which the following is a specification, reference being had to the annexed drawings, in which—

Figure 1 is a vertical transverse section; Fig. 2, a plan view, partly in section; Fig. 3, a vertical section with portions removed; and Fig. 4 is a plan view of the sheave-support.

The object of my invention is to provide for sheaves of ropes and bands a support which may be readily adjusted to any angle to enable the rope or band running over the sheave to take any desired direction.

My improvement is more especially designed for use in connection with wire-rope transmission of power in mines in and in other places where the machinery to be operated is distant from the prime mover.

My invention consists in an adjustable sheave-support hinged to the cap of a column and capable of being turned to any desired angle, either in a horizontal or in a vertical plane.

To the cast-iron base-piece A is fitted a tubular standard, B, preferably of wrought-iron pipe, receiving on its upper end a cap, C, which is secured thereto by a rivet, D, extending through a collar formed on the under side of the cap, and through the upper end of the tubular column B.

To the cap C is hinged a sheave-support, E, in which is secured centrally the pintle or pivot *a*, upon which the main sheave F turns. The support E has three shoulders, *b c d*, which are concentric with the pintle *a*.

Upon the shoulder *b* is supported a circular plate, G, receiving in its outer edge the fastenings of guy ropes or rods *e f*, by which the post B is supported rigidly in a vertical position. The shoulder *c* contains a circular T-shaped groove, *g*, for receiving the heads of bolts *h*, which bind arms *i* to the shoulder *c*.

To the free ends of the arms *i* are secured L-shaped arms *j* by bolts *k*, the arms *j* being slotted in their inner ends to admit of moving them on the bolts *k* into any desired position.

The angled ends of the arms *j* support the pivots *l* of sheaves *m* below the path of the rope passing around the sheave F. The support E is adjustable by the screw H, which passes through a semi-cylindrical nut, H', bearing in a semi-cylindrical socket formed in the cap C. The upper end of the pintle *a* is reduced in diameter and receives an arm, I, which is connected with the guy rope or rod *n*, and serves to support the outer end of the pintle. A nut, *o*, on the outer extremity of the pintle secures the arm I and the sheave E in place on the pintle. The tubular column B is capable of turning on the base A, and the sheave-support E may be adjusted to any desired angle by means of the screw H, and the arms *i j*, carrying the sheaves *m*, may be adjusted so as to bring the said sheaves *m* under the path of the rope at any point around the periphery of the sheave F.

By raising the support E by means of the screw H, and by turning the tubular column B on the base-plate A, the sheave F may be adjusted to any desired position without moving the guys *e, f*, or *n*, and when the desired angle is secured a wedge-shaped piece of hard wood may be inserted between the support E and the cap C, when the support E will be drawn down upon the wood and upon the cap C by means of clamps or bolts, rendering the adjustment permanent.

One of the main advantages of my improvement is that the bracing or guying being direct from the shaft or pintle of the sheave F renders the bearing of the said sheave very rigid, and makes it impossible for the adjustment of the angle of the sheave to change accidentally when once in position.

Having thus described my invention, what I claim as new, and desire to secure by Letters Patent, is—

1. The combination, with the rope supporting and guiding sheave F, of the column B, cap C, and support E, hinged to the said cap, substantially as herein specified.

2. The combination of the cap C, the support E, hinged thereto, and provided with a sheave-supporting pintle, *a*, and the adjusting-screw H and semi-cylindrical nut H', substantially as herein specified.

3. The combination, with the hinged sheave-

support E, of the plate G and guy ropes or rods *e f*, attached thereto, substantially as shown and described.

4. The combination, with the sheave-support E, of adjustable arms *i j* and rope-supporting sheaves *m*, as herein specified.

5. The combination, with the hinged sheave-support E and pintle *a*, of the arm I, for receiving the guy rope or rod *n*, as shown and  
10 described.

6. The combination, with the support E,

provided with the T-shaped slot *g*, of adjustable arms *i j*, fastening-bolts *h*, and sheaves *m*, carried by the said arms *i j*, as herein specified.

7. The combination with the sheave F, of the hinged support E, cap C, tubular stand-  
ard B, and base A, as herein specified.

ANDREW TROMBLEE.

Witnesses:

THOMAS F. WITHERBEE,  
JOHN W. WHITEHEAD.