

Feb. 20, 1934.

R. S. WENTWORTH

1,948,149

END SECTION FOR CONVECTORS

Filed March 26, 1932

4 Sheets-Sheet 1

Fig. 2

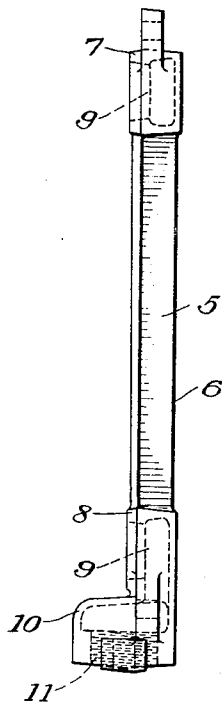

Fig. 1

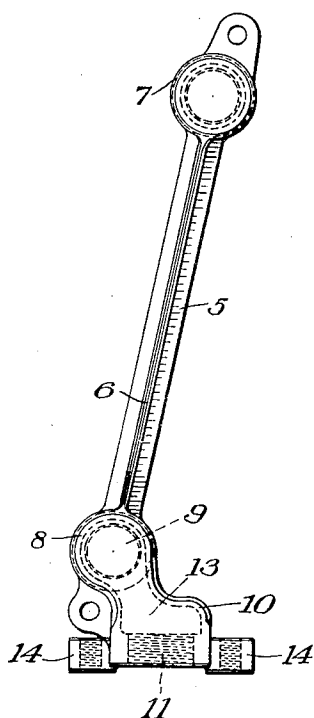

Fig. 3

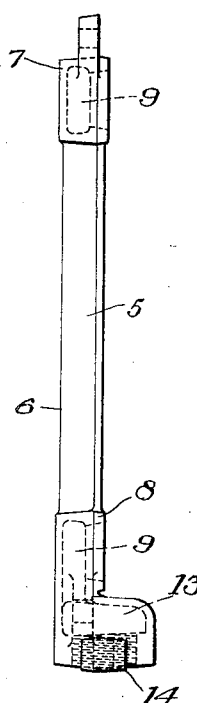

Fig. 4

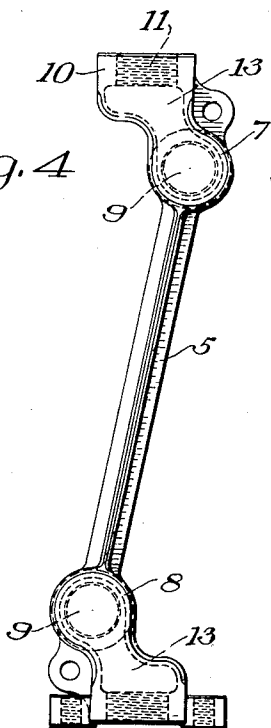
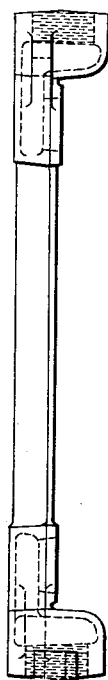

Fig. 5



INVENTOR
Robert S. Wentworth
by his attorneys
Byrnes, Stebbins, Parmelee and Glendon

Feb. 20, 1934.

R. S. WENTWORTH

1,948,149

END SECTION FOR CONVECTORS

Filed March 26, 1932

4 Sheets-Sheet 2

Fig. 6

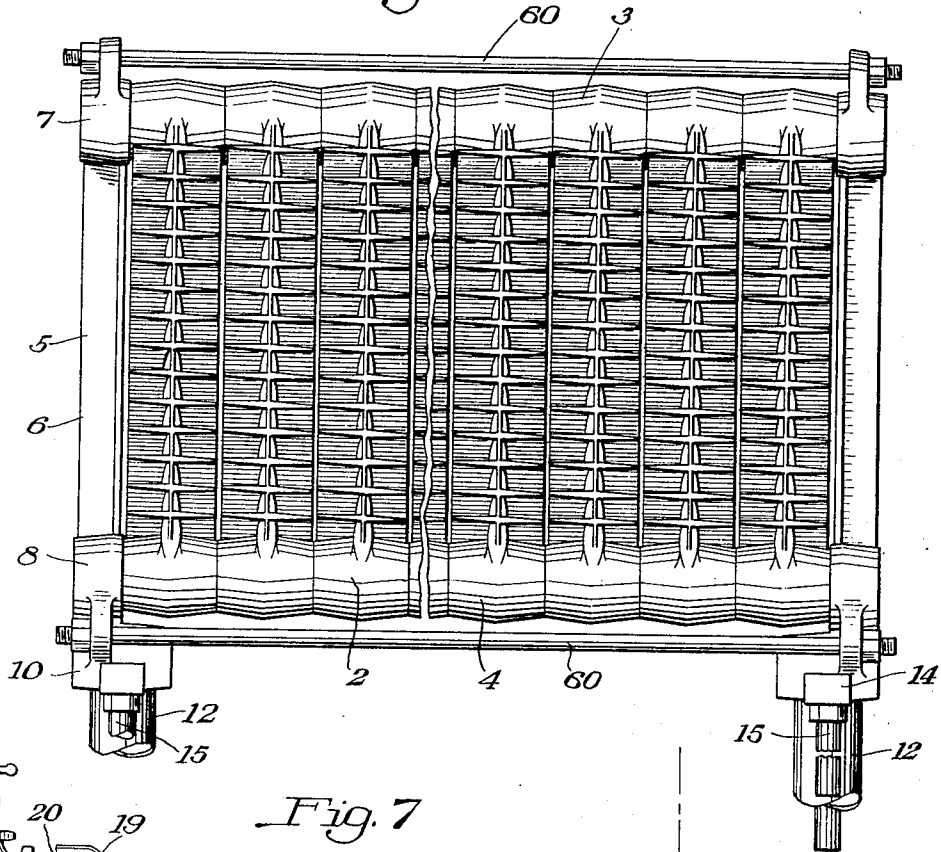
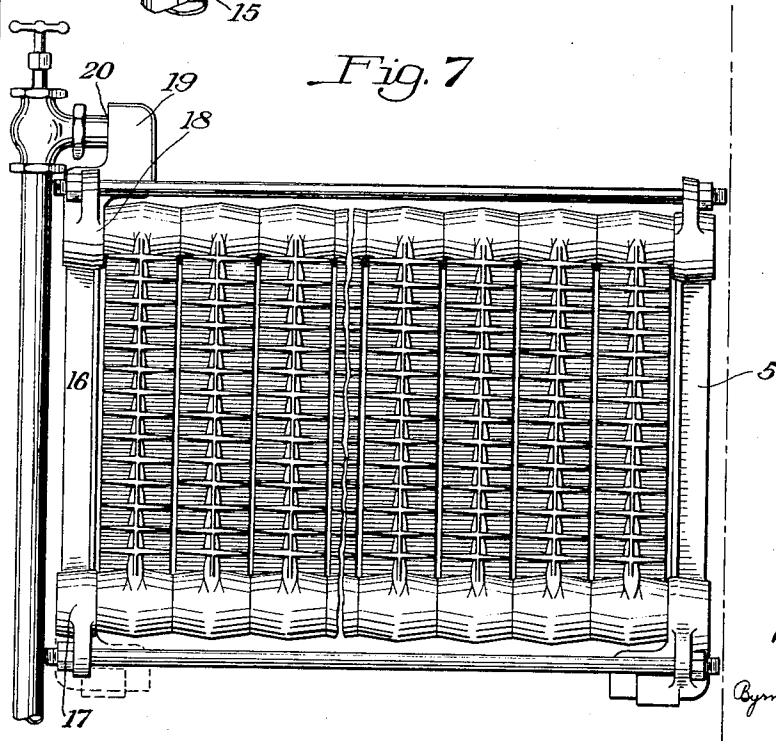

Fig. 7



INVENTOR
Robert S. Wentworth
by his attorneys
Clymes, Stebbins, Parmelee and Blankens

Feb. 20, 1934.

R. S. WENTWORTH

1,948,149

END SECTION FOR CONVECTORS

Filed March 26, 1932

4 Sheets-Sheet 3

Fig. 8

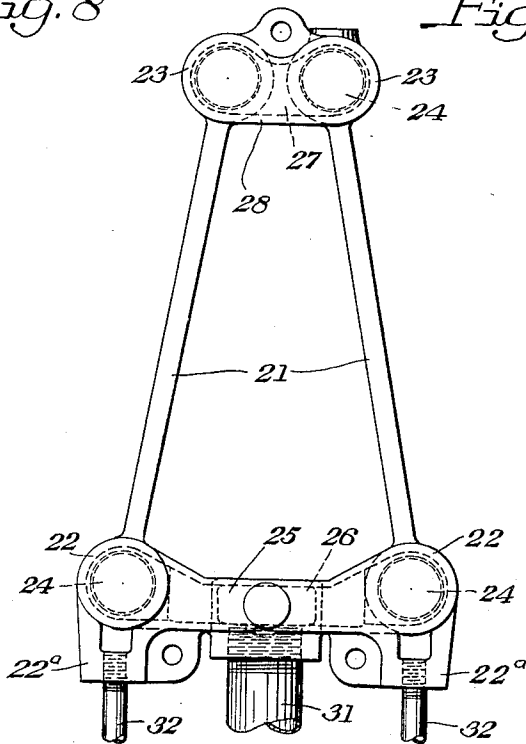

Fig. 9

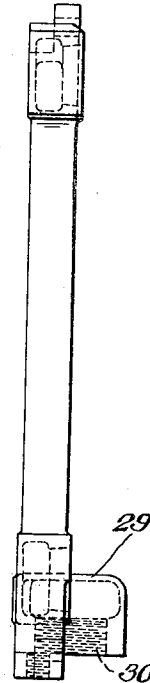

Fig. 10

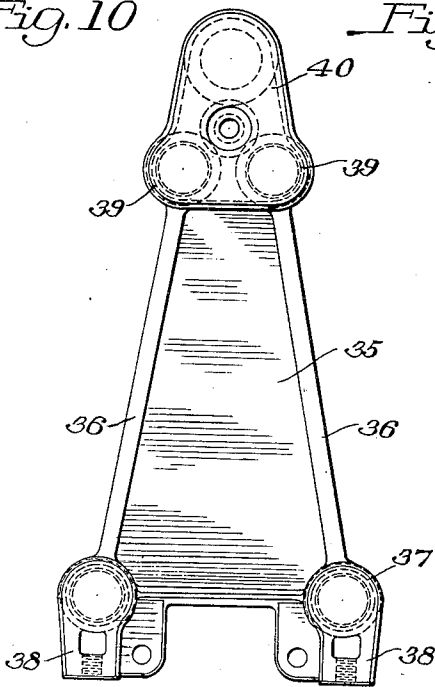
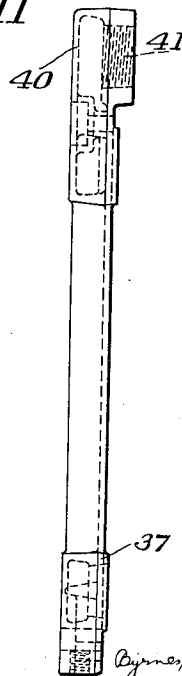

Fig. 11



INVENTOR

Robert S. Wentworth

by his attorneys

Clymer, Stubbins, Parmelee and Blenko

Feb. 20, 1934.

R. S. WENTWORTH

1,948,149

END SECTION FOR CONVECTORS

Filed March 26, 1932

4 Sheets-Sheet 4

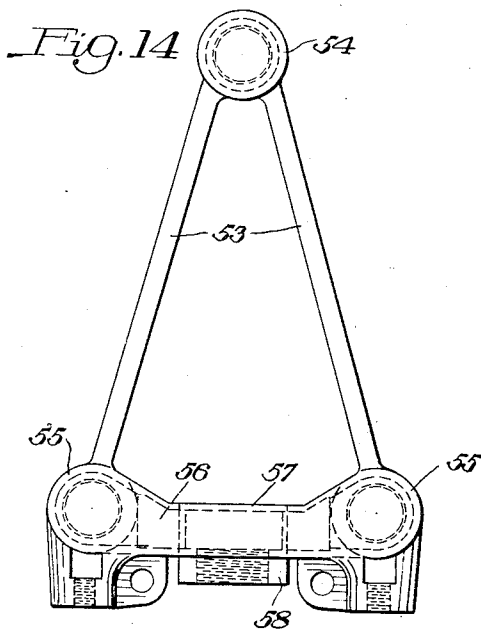
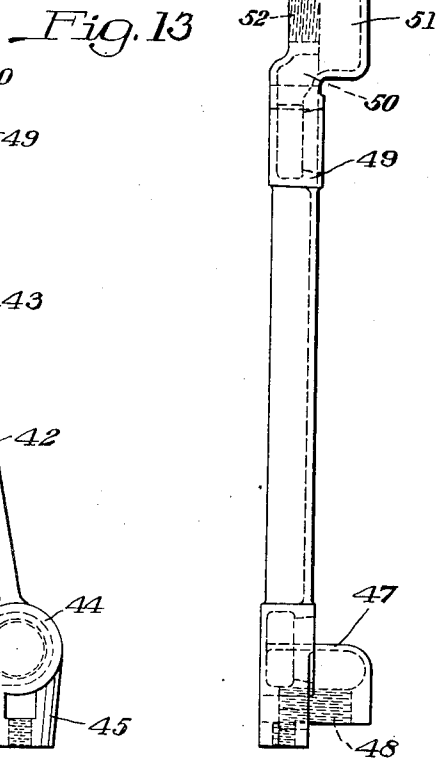
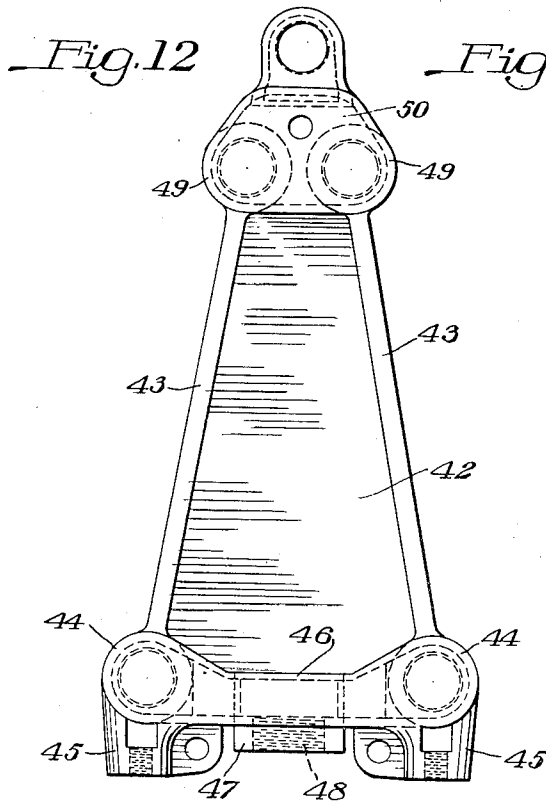

INVENTOR
Robert S. Wentworth
by his attorneys
Byrne, Stebbins, Arnold and Blenko

UNITED STATES PATENT OFFICE

1,948,149

END SECTION FOR CONVECTORS

Robert S. Wentworth, Johnstown, Pa., assignor to
National Radiator Corporation, Johnstown, Pa.,
a corporation of Delaware

Application March 26, 1932. Serial No. 601,325

11 Claims. (Cl. 257—151)

This invention pertains to heating devices of the type known as "convectors", and is for an end member to be used in connection with a convector formed of a plurality of individual sections.

In my copending application Serial No. 513,883, filed February 6, 1931, which has now matured into Patent No. 1,912,556, issued June 6, 1933, I have disclosed a convector formed of a plurality of cast metal sections, the convector having inclined heat dissipating fins thereon, the convector itself being arranged to set at an angle to a vertical position. In my copending application Serial No. 514,757, filed February 10, 1931, there is disclosed a convector operating in accordance with the same principle but wherein the convector is inclined in two directions. According to either construction, the convector is made up of cast metal sections and all of the sections are of uniform width.

In installing the convector in a cabinet built to receive it, it is of course desirable to use the greatest number of sections possible in order that there may be no space left over in the cabinet. At the same time, different installations require the use of heat control valves at different places. For instance, some installations require the presence of a valve operating handle at the front of the cabinet near the floor line. Other installations require the location of the valve adjacent the top of the convector with an operating handle conveniently disposed in the top of the cabinet. For instance, where the cabinet is located directly in front of a window and the grille at the top of the cabinet flush with the window sill, the operating handle for the radiator valve is frequently at the top of this grille.

The present invention provides an end section for convectors of either the single or double type constructed to occupy a minimum space and arrange for supporting the convectors within the cabinet. The invention further provides end sections wherein the connections may be conveniently located and wherein the valves may be conveniently disposed with the loss of a minimum of cabinet space.

The invention may be readily understood by reference to the accompanying drawings, in which

Figure 1 represents a front elevation of one end member;

Figure 2 is a side elevation of the member turned in one direction for use at one end of the convector section;

Figure 3 is a similar view showing the reversed end member for use at the other end of the convector;

Figure 4 is a view similar to Figure 1 of a slightly modified construction having pipe connections at the top and bottom;

Figure 5 is a side elevation of the end member shown in Figure 4;

Figure 6 is a front elevation of a convector assembly in which two members similar to those shown in Fig. 1 are employed;

Figure 7 is a view similar to Figure 6 showing a similar assembly wherein one of the end sections is of the type shown in Figure 4 and the other is of the type shown in Figure 1;

Figure 8 is an elevation of an end member for a double sloping convector;

Figure 9 is a side elevation of the member shown in Figure 8;

Figure 10 is a view similar to Figure 8 of another modified construction;

Figure 11 is a side elevation of the member shown in Figure 10;

Figure 12 is a view similar to Figure 10 of another modified form;

Figure 13 is a side elevation of the form shown in Figure 12; and

Figure 14 is a view similar to Figure 12 of another modification for use with a double sloping fin convector wherein the double sloping fins join a common header.

Referring first to the construction shown in Figures 1 and 6, I have shown in Figure 6 a convector 2 formed of a plurality of cast metal sections having header portions 3 at the top thereof and header portions 4 at the bottom thereof, these sections being provided with heat radiating fins. This particular form of convector is the subject of my copending application Serial No. 1,513,883, filed February 6, 1931, in which it is claimed, and it is disclosed in the present application merely by way of illustration. The convector sets at an angle to the vertical plane, for the reasons explained in my said application. Because of the angle at which the convector sets, the header portions 3 are disposed to one side of the header portions 4.

The installation of the convectors requires that they be supported in the cabinet in which they are ordinarily placed and that they be maintained at the proper angle. For this purpose the present invention provides an end member at each end of the convector. This end member in Figures 1 and 6 is designated generally by the reference numeral 5. The end member prefer-

ably comprises an integral cast structure having a central post portion 6. At the top of the post portion 6 is a hub portion 7 and at the bottom of the post portion 6 is a similar hub portion 8. These hub portions are provided with recesses 9 into which push nipples similar to those used for uniting the convector sections may project. These push nipples are not shown, but are of the conventional type. When the nipples are forced into the recesses 9, the portions 7 and 8 form an effective closure for the end of the convector.

At the bottom of the end member is an offset connector portion 10 having a threaded opening 11 in the bottom thereof into which a pipe, such as the pipe 12 of Figure 6, may be screwed. A passage 13 leads from the portion 10 into the recess 9 in the hub portion 8 at the bottom of the member. It will be observed by reference to Figure 1 that the portion 10 is laterally offset with respect to the center of the hub portion 8 and that the post 6 is inclined at an angle, which angle corresponds to the slope at which the convector is set. By reason of the lateral offsetting of the portion 10 with respect to the center of the hub 8, the pipe 12 may conveniently be positioned in the middle of the cabinet in which the convector is housed, instead of being placed close to the front or rear wall thereof.

It will also be noted by reference to Figure 2 that the portion 10 is rearwardly offset so that when the member 5 is applied to the convector the hub portion 10 turns under the convector. By reason of this, the pipe 12 can come up under the convector and space at the ends of the convector is saved. As a matter of fact, the two members 5 occupy a space equal to that of a single section of the convector.

The portion 10 is provided at each side thereof with lugs 14. Threaded rods 15 screw into these lugs, providing adjustable legs. By reason of these adjustable legs the convector can be supported above the floor line and by screwing the legs up and down the proper vertical adjustment can be secured for taking care of any inequalities in the floor level, or for changing the angle of the convector slightly, or for adjustment of the convector as a whole.

Where, however, the requirements of an installation make it desirable to provide an inlet pipe connected at the top of the convector and an outlet pipe leading from the bottom of the other end of the convector, a section such as that shown in Figure 4 may be used.

In this figure the construction shown at the lower end of the column is duplicated at the upper end of the column. The connector 11, not in use with this type of structure, may be plugged up. Since convectors of this type are always housed, the presence of the unused connector is not undesirable from the standpoint of appearance. It is, of course, not necessary to provide the lugs 14 at each end of the section.

In the construction shown in Figure 7 the convector is provided with one end member 5 similar to that shown in Figure 6. However, the end member at the other end of the structure is of slightly modified form. This other end member, shown at the left in Figure 7, comprises a vertical post 16 having a hub portion 17 at the lower end similar to the hub portion 7 of the construction shown in Figure 1. At the upper end of the column is a hub portion 18 and a laterally and rearwardly offset connector portion 19 having a pipe connection 20 in the vertical face thereof. There is an interior passage within the portion 19, so

that steam or other heating fluid may flow from the connection 20 through the portion 19 into the hub portion 18 and thence into the convector. This arrangement permits the valve to be located at the top of the convector and the steam pipe to be located at the end of the convector without requiring any more space than is required for the pipe alone.

In the double type of convector, as shown in my application Serial No. 514,757, filed February 10, 1931, there are, in reality, two convectors arranged together and sloping in opposite directions. With such a convector the end member shown in Figures 8 and 9 may be used. This member comprises spaced apart post portions 21 sloping in opposite directions, having hub portions 22 at the bottom thereof and hub portions 23 at the top thereof. These hub portions are provided with sockets 24 for the insertion of push nipples, as described in connection with Figure 1. The two hub portions 22 communicate with each other through a cross member 25 having a passageway 26 therein and the recesses in the two hub members 23 are connected by a passage 27 in a cross member 28 at the top of the end section. The cross member 25 is provided with an inwardly offset connector portion 29 having a downwardly opening screw threaded port 30 therein into which a pipe 31 may be screwed. The passage within the lug 29 communicates with the passage 26. Steam entering the convector through the pipe 31 flows into the passage 26 and thence into both sides of the convector. The passage of steam is provided for at the top of the convector through the cross passages 27. In this structure also the end member is reversible so that the same fitting may be used at each end of the convector, and in this form also the connector portion 29 is inwardly or rearwardly offset so as to extend under the radiator and not require extra space at the end thereof for the pipe connection 31.

Under each of the hub portions 22 are lug portions 22a having threaded openings therein for the reception of screw threaded legs 32.

The end member shown in Figures 10 and 11 is generally similar to the arrangement shown in Figures 8 and 9 with the exception that provision is made for connecting a pipe to the top of the section instead of the bottom. In this form of the invention the end member, instead of having two separated posts with an open space between them, as in Figure 8, has a web 35 with a rib portion 36 at each side thereof. The portions 36 correspond to the post portions 21 of the structure shown in Figure 8. On each of the lowermost corners of the members are hub portions 37 with recesses therein for the reception of push nipples, as heretofore explained, and below these are lugs 38 into which the legs may be screwed. At the top of the structure are separated bosses 39 also having recesses therein for the reception of push nipples and the recesses therein communicate with each other and with the interior of an upwardly extending portion 40. The upwardly extending portion 40 is provided with an opening 41 in one face thereof, this opening being threaded in order that a pipe may be screwed into it.

In this form there is no communication between the hub portions 37 and the communication between the oppositely sloping sections is established at the top of the end member. The web 35 serves to close the end of the convector and thereby confine the air flow through the convector.

The end member shown in Figures 12 and 13

corresponds generally to that shown in Figures 10 and 11, with the exception that it also combines the arrangement shown in Figures 8 and 9, permitting the water or steam to be brought in at either the top or the bottom of the end member. Moreover, in this construction the extension at the top into which the pipe is screwed is offset out of the plane of the end member to secure the advantages of the arrangement described in Figure 7, where a valve is to be located adjacent the top of the convector.

In Figures 12 and 13, the numeral 42 designates a web having rib portions 43 at each side thereof. At the lowermost corners of the web 42 are hub portions 44 with recesses therein for the reception of push nipples and below these hubs 44 are lugs 45 into which threaded supporting legs (not shown) may be screwed. The hubs 44 are connected by a cross portion 46 having a passageway therein connecting the recesses of the two hubs. Means for connecting the pipe to this cross portion is provided by an offset lug 47 having a downwardly opening internally threaded port 48. A pipe can be screwed into this port, or a plug can be screwed into it, depending upon the manner in which the end member is used. At the top of the web are two other spaced apart hub portions 49. These communicate with each other through a hollow top portion 50, this top portion having an extension 51 thereon which is offset from the plane of the web and which has an internally threaded passageway 52 therein. The advantage of this member is that it can be used at either end of the convector with the steam inlet pipe coming into the top of the convector and the exhaust pipe leading from the bottom of either end of the convector.

In the arrangement shown in Figure 14 the structure is substantially the same as that of Figure 8, except that there is only a single recess at the top of the end member. This type of end member is used in a convector where the oppositely sloping sections of the convector communicate with a single header.

In the construction shown in Figure 14 there are upwardly converging side bars 53 having hub portions 54 at the top thereof with a recess therein for the reception of a nipple. At the lower end of each bar or leg 53 is a hub portion 55, these hub portions also having recesses therein. The recesses are connected by a passageway 56 in a cross member 57. This cross member is provided with an offset connector portion 58 similar to the offset connector portion 29 of the member shown in Figure 8.

It will be understood that several modifications of the invention have been shown and described, not by way of limitation, but for the purpose of illustrating several different ways in which the end member can be adapted to convectors of different forms. Various features of the separate modifications herein described can be combined and re-arranged, as will be apparent to those skilled in the art, and the invention is not limited to the particular constructions shown.

In each case the end member is provided with hub portions having recesses therein for the reception of push nipples, these recesses being so positioned that they line up with header portions of the particular style of convector with which they are designed to be used. The end members provide means not only for closing the ends of the convectors, but provide the con-

vector portions through which fluids are let into the convector and removed therefrom. Moreover, the end members, being provided with legs, take care of the proper supporting of the convector at the proper angle within the cabinet or other space into which it is placed, and by reason of the fact that some or all of the legs are adjustable, adjustment can be made for unevenness in the floor or for any other special condition.

In each form of the invention illustrated provision is made for one or more tie rods at the top of the convector, and one or more tie rods at the bottom thereof. These tie rods are designated in each figure by the reference numeral 60, the end members being provided with lugs or eyes through which the tie rods pass. Thus the end members not only serve to close the convector and provide supporting means therefor, and provide for the connection of pipes thereto, but they also serve to hold the convector assembly together.

Moreover, as previously explained, each end member occupies a space equal to only half the width of one of the convector sections so that the two end members require a space in the cabinet equal only to the space of a single convector section. By reason of this relation of the end members to the width of a section, the maximum number of sections which can be used in any given cabinet can be easily calculated with assurance that provision may be made for the necessary piping.

I claim:

1. An end section for convectors comprising an intermediate supporting portion having a hub portion at the top thereof and a hub portion at the bottom thereof, said hub portions having recesses therein adapted to line up with header portions of the convector on which the end member is to be used, one of said hub portions having a connector portion communicating therewith, said connector portion being offset from the plane of the intermediate portion of the end member and toward the vertical axis of the end member.
2. An end section for convectors comprising an intermediate supporting portion having a hub portion at the top thereof and a hub portion at the bottom thereof, said hub portions having recesses therein adapted to line up with header portions of the convector on which the end member is to be used, one of said hub portions having a connector portion communicating therewith, and adjustable legs adjustably relatively to each other detachably secured to the lower portion of the end member.
3. An end member for use with convectors comprising an intermediate upright portion having a hub portion at the top thereof and a hub portion at the bottom thereof, the center line between the two hub portions being at an angle to a vertical plane, each of said hub members having a recess therein, and a connector portion at the top of the end member communicating with the recess in the said upper hub portion, said connector portion being offset from the plane of the intermediate part of the end member whereby it projects over the convector with which the end member is used.
4. An end member for use with convectors comprising an intermediate upright portion having a hub portion at the top thereof and a hub portion at the bottom thereof, the center line between the two hub portions being at an angle to a vertical plane, each of said hub members having a recess therein, and a connector portion

at the top of the end member communicating with the recess in the said upper hub portion, said connector portion being offset from the plane of the intermediate part of the end member whereby it projects over the convector with which the end member is used, said connector portion also being offset to one side of the center of the upper hub member.

5. An end member for use with convectors comprising an intermediate upright portion having a hub portion at the top thereof and a hub portion at the bottom thereof, the center line between the two hub portions being at an angle to a vertical plane, each of said hub members having a recess therein, a connector portion at the top of the end member communicating with the recess in the said upper hub portion, said connector portion being offset from the plane of the intermediate part of the end member whereby it projects over the convector with which the end member is used, and a connector portion communicating with the bottom hub portion.

6. The combination with a convector having a plurality of vertically extending inclined sections, which sections have header portions at the top and bottom thereof, of an end member comprising an intermediate leg having a hub portion at the top thereof in line with the header portions at the top of the convector, and having a hub portion at the bottom thereof in line with the header portions at the bottom of the convector, said hub portions having recesses therein, and a connector portion to which a pipe may be connected at one end of the end member opening into the recess of the hub portion to which it is adjacent.

7. The combination with a convector having a plurality of vertically extending inclined sections, which sections have header portions at the top and bottom thereof, of an end member comprising an intermediate leg having a hub portion at the top thereof in line with the header portions at the top of the convector, and having a hub portion at the bottom thereof in line with the header portions at the bottom of the convector, said hub portions having recesses therein, and a connector portion to which a pipe may be connected at one end of the end member opening into the recess of the hub portion to which it is adjacent, the end member occupying a space in the assembly not substantially exceeding half the width of a convector section.

8. The combination with a convector having a plurality of vertically extending inclined sections, which sections have header portions at the top and bottom thereof, of an end member com-

prising an intermediate leg having a hub portion at the top thereof in line with the header portions at the top of the convector, and having a hub portion at the bottom thereof in line with the header portions at the bottom of the convector, said hub portions having recesses therein, and a connector portion to which a pipe may be connected at one end of the end member opening into the recess of the hub portion to which it is adjacent, the end member occupying a space in the assembly not substantially exceeding half the width of a convector section, the said connector portion being offset to overlap the first section of the convector.

9. An end member for convectors comprising a substantially triangular frame having a hub portion at the bottom thereof at each corner of the triangular frame, and having two hub portions spaced closer together at the top thereof, all of said hub portions having recesses therein adapted to aline themselves with openings in the convector with which the end member is used, the two hub portions at one end of the frame being connected by a cross passage, and a pipe connection portion communicating with the cross passage.

10. An end member for convectors comprising a substantially triangular frame having a hub portion at the bottom thereof at each corner of the triangular frame, and having two hub portions spaced closer together at the top thereof, all of said hub portions having recesses therein adapted to aline themselves with openings in the convector with which the end member is used, the two hub portions at one end of the frame being connected by a cross passage, a pipe connection portion communicating with the cross passage, and adjustable leg members at the bottom of the triangular frame.

11. An end member for convectors comprising a substantially triangular frame having a hub portion at the bottom thereof at each corner of the triangular frame, and having two hub portions spaced closer together at the top thereof, all of said hub portions having recesses therein adapted to aline themselves with openings in the convector with which the end member is used, the two hub portions at one end of the frame being connected by a cross passage, and a pipe connection portion communicating with the cross passage, said connector portion being offset out of the plane of the frame so as to extend under or over the convector with which the end member is used.

ROBERT S. WENTWORTH.

5

10

15

20

25

30

35

40

45

50

55

60

65

70

75

80

85

90

95

100

105

110

115

120

125

130

135

140

145

150