

(19)
(12)

(KR)
(A)

(51) 。 Int. Cl. ⁷
H05B 33/10

(11)
(43)

2002 - 0037608
2002 05 22

(21) 10 - 2000 - 0067630
(22) 2000 11 15

(71) 167 - 1

(72) 248 40 3 6 - 512
6 1 121 305
481 - 1 101 - 702
441 - 1 110 1301

(74)
:

(54)

1a

1b

1c

1d

2a

2c

*

*

21 :

22 :

23 :

100 :

md :

가 (Electroluminescent) , 가 EL , 가 (LCD) , 가 , 가
 (CNS, Car Navigation System), EL TV LCD 가 , ,
 1a , (11) ITO (12),
 (13) (14) , EL (11) (16)
 UV (15)) ,
 (12) EL (12) (+) 가 , (14) (-) 가 (13)
 (13) , (14) 가
 , EL (12), (13) (14)
 , 1b (md) 가 ,
 , 가 , 1c 가 ,
 가

md) 가 가 1d (

가

1 ~ 3um

가

()

2 (22) 2a (22) (21)

3) 2b (23) (22) (21) (22a) (22) (2)

(100) (22) (23)

(100) (100)

(100) um

가 , 1

가 (100)

(100)

(100)

(23)

(23)

, 2c
(23)

, (100)
(md)

, (md) (md) EL

(22) 가
가 (

R.G.B
(100)

가
가

(md)

가 ,

2
가

(100)

(md)

(100)

가 .

가 , 가

(57)

1.

2.

1 , 가

3.

1 , 1 ~ 3um

4.

1 ,

5.

1 , ,

6.

1 ,

7.

1 ,

8.

9.

8 , 가

10.

8 , ,

11.

8 ,

12.

8 ,

1a

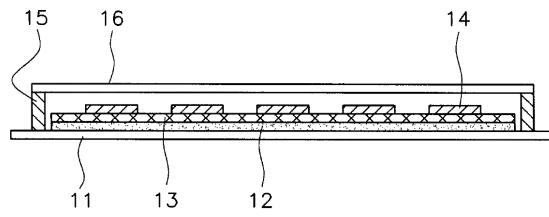

1b

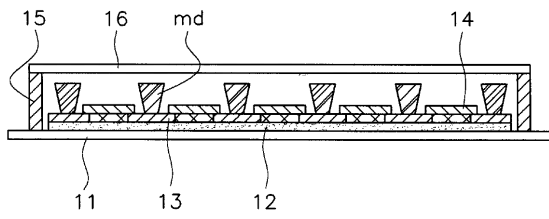

1c

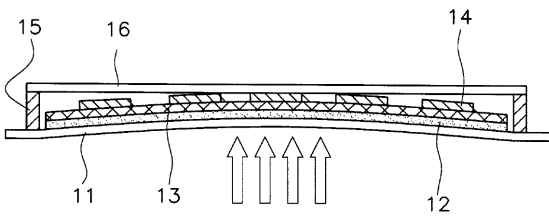

1d

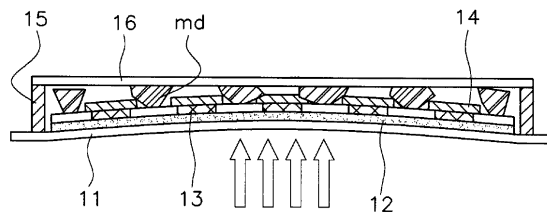

2a

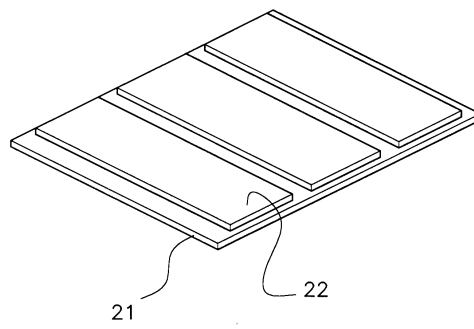

2b

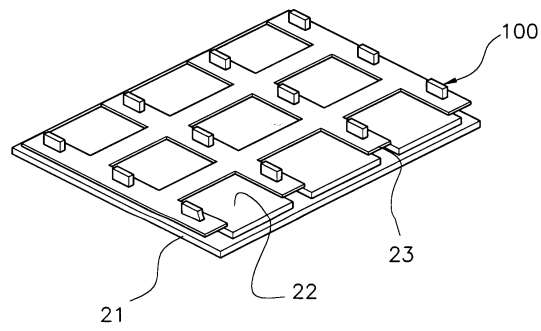

2c

