



(22) Date de dépôt/Filing Date: 2009/06/18  
(41) Mise à la disp. pub./Open to Public Insp.: 2010/12/23  
(45) Date de délivrance/Issue Date: 2023/03/28  
(62) Demande originale/Original Application: 3 048 386

(51) Cl.Int./Int.Cl. *H04N 19/52* (2014.01),  
*H04N 19/139* (2014.01), *H04N 19/176* (2014.01)

(72) Inventeurs/Inventors:  
ASAKA, SAORI, JP;  
CHUJOH, TAKESHI, JP;  
TANIZAWA, AKIYUKI, JP;  
YASUDA, GOKI, JP;  
WADA, NAOFUMI, JP;  
WATANABE, TAKASHI, JP

(73) Propriétaire/Owner:  
KABUSHIKI KAISHA TOSHIBA, JP

(74) Agent: MARKS & CLERK

(54) Titre : APPAREIL DE CODAGE VIDEO, APPAREIL DE DECODAGE VIDEO ET METHODES ASSOCIEES  
(54) Title: VIDEO ENCODING APPARATUS, VIDEO DECODING APPARATUS AND RELATED METHODS

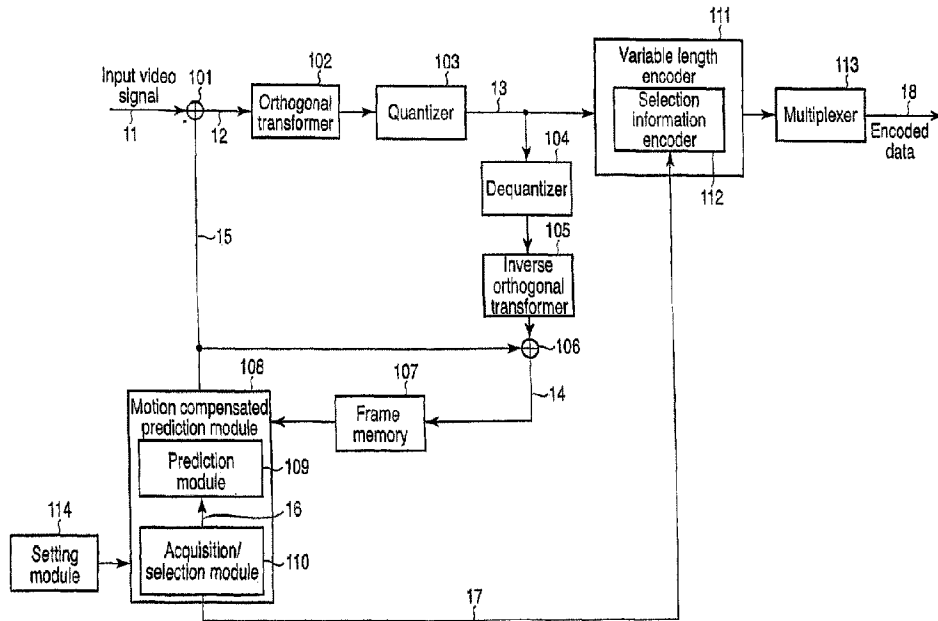

(57) **Abrégé/Abstract:**

The present invention provides a video decoding apparatus that improves degrees of freedom for calculating a motion vector by selecting one from enclosed blocks. The video decoding apparatus comprises processing circuitry configured to: acquire one or more available blocks having a motion vector from decoded blocks adjacent to a to-be-decoded block and a number of the available blocks; select a first block from the available blocks; select a plurality of code words based on the number of the available blocks; and decode selection information specifying the first block from the available blocks using a code table corresponding to the first block from the available blocks, the code table including index and code words corresponding to the index, and the to-be-decoded block by using a motion vector of the first block, wherein a number of the index is determined depending on the number of the available blocks.

## ABSTRACT

The present invention provides a video decoding apparatus that improves degrees of freedom for calculating a motion vector by selecting one from enclosed blocks. The video decoding apparatus comprises processing circuitry configured to: acquire one or more available blocks having a motion vector from decoded blocks adjacent to a to-be-decoded block and a number of the available blocks; select a first block from the available blocks; select a plurality of code words based on the number of the available blocks; and decode selection information specifying the first block from the available blocks using a code table corresponding to the first block from the available blocks, the code table including index and code words corresponding to the index, and the to-be-decoded block by using a motion vector of the first block, wherein a number of the index is determined depending on the number of the available blocks.

VIDEO ENCODING APPARATUS, VIDEO DECODING APPARATUS  
AND RELATED METHODS

5 This is a divisional application of Canadian Patent  
Application Serial No. 3,048,386, which is a divisional  
application of Canadian Patent Application Serial No.  
2,969,723 (patent issued on August 27, 2019) which is a  
divisional application of Canadian Patent Application Serial  
No. 2,929,824 (patent issued on July 18, 2017) which is a  
10 divisional application of Canadian Patent Application Serial  
No.2,845,186 (patent issued on August 16, 2016) which is a  
divisional application of Canadian Patent Application Serial  
No. 2,765,828 filed on June 18, 2009 (patent issued on April  
19, 2016).

15

Technical Field

The present invention relates to a video encoding  
apparatus and a video decoding apparatus which derive a motion  
vector from an encoded and decoded image and perform a motion  
20 compensated predication. It should be understood that the  
expression "the invention" and the like used herein may refer  
to subject matter claimed in either the parent or the  
divisional applications.

25

Background Art

There is a motion compensated prediction as one of  
techniques used for encoding a video image.

In the motion compensated prediction, a video encoding  
apparatus acquires a motion vector using a to-be-encoded image  
30 to be newly encoded and a local decoded image already

generated and generates a prediction image by carrying out motion compensation using this motion vector.

As one of methods for acquiring a motion vector in the motion compensated prediction, there is a direct mode for generating a prediction image using a motion vector of a to-be-encoded block derived from the motion vector of an encoded block (refer to Japanese Patent No. 4020789 and U.S. Patent No. 7233621). Because the motion vector is not encoded in the direct mode, the number of encoded bits of the motion vector information can be reduced. The direct mode is employed

in H.264/AVC.

#### Disclosure of Invention

In the direct mode, a motion vector is generated by a method for calculating a motion vector from a median value of the motion vector of an encoded block adjacent to a to-be-encoded block in generating the motion vector of the to-be-encoded block by prediction. Therefore, degrees of freedom for calculating the motion vector calculation are low. In addition, when a method for calculating a motion vector by selecting one from a plurality of encoded blocks is used for improving the degrees of freedom, the position of the block must be always sent as motion vector selection information in order to indicate the selected encoded block. For this reason, the number of encoded bits may be increased.

It is an object of the present invention to provide a video encoding apparatus and a video decoding apparatus which reduce additional information of motion vector selection information while improving the degrees of freedom for calculating the motion vector by selecting one from encoded blocks.

An aspect of the present invention provides a video encoding apparatus for subjecting a video image to motion compensated encoding, the apparatus comprising:

an acquisition module to acquire available blocks of blocks having motion vectors and a number of the available

blocks from encoded blocks adjacent to a to-be-encoded block;

a selection module to select one selection block from the available blocks;

5 a selection information encoding module to select one selection code table from a plurality of code tables depending on the number of the available blocks and encode selection information for specifying the selection block using the selected code table; and

10 an image encoding module to subject the to-be-encoded block to motion compensated prediction coding using a motion vector of the selection block.

Another aspect of the present invention provides a video decoding apparatus for subjecting a video image to motion  
15 compensated prediction decoding, the apparatus comprising: an acquisition module to obtain available blocks being blocks having motion vectors and a number of the available blocks from decoded blocks adjacent to a to-be-decoded block; a selection information decoding module to select one selection  
20 code table from a plurality of code tables having different numbers of entries depending on the number of the available blocks and decode selection information for specifying the selection block using a code table corresponding to the number of the available blocks; a selection module to select one  
25 selection block from the available blocks according to the selection information; and a video decoding module to subject the to-be-decoded block to motion compensated prediction decoding using a motion vector of the selection block.

According to a further aspect of the present invention there is provided a video decoding apparatus for subjecting a video image to motion compensated prediction decoding, the apparatus comprising:

- 5 an acquisition module configured to acquire available blocks having motion vectors and a number of the available blocks from decoded blocks adjacent to a to-be-decoded block, wherein the acquisition module is configured to acquire the available blocks by extracting available blocks from available  
10 block candidates based on at least one of a set of respective block sizes, a set of their prediction modes and the prediction mode of the to-be-decoded block, wherein the available block candidates are decoded neighboring blocks having a motion vector;
- 15 a selection information decoding module to select one selection code table from a plurality of code tables depending on the number of the available blocks and decode selection information for specifying the selection block using the selected code table;
- 20 a selection module to select the selection block from the available blocks according to the selection information; and  
a video decoding module to subject the to-be-decoded block to motion compensated prediction decoding using a motion vector of the selection block.

According to an aspect of the present invention there is provided a video encoding apparatus for subjecting a video image to motion compensated encoding, the apparatus comprising:

an acquisition module to acquire available blocks of blocks having motion vectors from encoded blocks adjacent to a to-be-encoded block and a number of the available blocks;

a selection module to select one selection block, from the available blocks;

a selection information encoding module to encode selection information specifying the selection block using a code table corresponding to the number of available blocks; and

an image encoding module to subject the to-be-encoded block to motion compensated prediction coding using a motion vector of the selection block.

In some embodiments, the acquisition module acquires as the available block a block of a specific block size having a motion vector from the encoded blocks.

In some embodiments, the video encoding apparatus further comprises a setting module to set a prediction mode of the to-be-encoded block to any one of

(A) a first unidirectional prediction using only a first vector,

(B) a second unidirectional prediction using only a second vector, and

(C) a bidirectional prediction using both the first vector and the second vector,

wherein the acquisition module acquires as the available block a block of a specific block size having a motion vector necessary for subjecting the to-be-encoded block to motion compensated prediction in the prediction mode.

In some embodiments, the video encoding module subjects the to-be-encoded block to motion compensated prediction coding using a quantization parameter of the selection block.

According to a further aspect of the present invention there is provided a video decoding apparatus for subjecting a video image to motion compensated prediction decoding, the apparatus comprising:

- an acquisition module to obtain available blocks being blocks having motion vectors and a number of the available blocks from decoded blocks adjacent to a to-be-decoded block;

- a selection information decoding module to decode selection information specifying the selection block using a code table corresponding to the number of the available blocks;

- a selection module to select one selection block from the available blocks according to the selection information; and

- a video decoding module to subject the to-be-decoded block to motion compensated prediction decoding using a motion vector of the selection block.

In some embodiments, the acquisition module acquires as the available block a block of a specific block size having a motion vector from the encoded block.

In some embodiments, the video decoding apparatus further comprises a setting module to set a prediction mode of the to-be-decoded block to any one of

(A) a first unidirectional prediction using only a first vector,

(B) a second unidirectional prediction using only a second vector, and

(C) a bidirectional prediction using both the first vector and the second vector,

wherein the acquisition module acquires as the available block a block of a specific block size having a motion vector necessary for subjecting the to-be-decoded block to motion compensated prediction in the prediction mode.

In some embodiments, the video decoding module subjects the to-be-decoded block to motion compensated prediction coding using a quantization parameter of the selection block.

According to another aspect of the present invention there is provided a video decoding apparatus for subjecting a video image to motion compensated decoding, the apparatus comprising:

an acquisition module to acquire one or more available blocks having a motion vector and a number of the available blocks from decoded blocks adjacent to a to-be-decoded block;

a selection information decoding module to decode selection information specifying one of the available blocks using a code table having the same number of entries as the number of the available blocks and not to decode the selection information when the number of the available blocks is 1;

3d

a selection module to select a selected block from the available blocks according to the selection information; and  
an image decoding module to decode the to-be-decoded block using a motion vector of the selected block.

According to a further aspect of the present invention there is provided a video decoding method for subjecting a video image to motion compensated decoding, the method comprising:

acquiring one or more available blocks having a motion vector and a number of the available blocks from decoded blocks adjacent to a to-be-decoded block;

decoding selection information specifying one of the available blocks using a code table having the same number of entries as the number of the available blocks and not

decoding the selection information when the number of the available blocks is 1;

selecting a selected block from the available blocks according to the selection information; and

5 decoding the to-be-decoded block by using a motion vector of the selected block.

According to a further aspect of the present invention there is provided a computer-readable medium storing  
10 instructions that, when executed, cause a computer to subject a video image to motion compensated decoding, the instructions causing the computer to execute;

a step of acquiring one or more available blocks having a motion vector and a number of the available blocks from  
15 decoded blocks adjacent to a to-be-decoded block;

a step of decoding selection information specifying one of the available blocks using a code table having the same number of entries as the number of the available blocks and not decoding the selection information when the number of the  
20 available blocks is 1;

a step of selecting a selected block from the available blocks according to the selection information; and

a step of decoding the to-be-decoded block by using a motion vector of the selected block.

25

According to a further aspect of the present invention there is provided a video decoding apparatus for subjecting a video image to motion compensated decoding, the apparatus decoding an encoded data by performing:

30 acquiring one or more available blocks having a motion vector and a number of the available blocks from decoded blocks adjacent to a to-be-decoded block;

decoding selection information specifying one of the available blocks using a code table having the same number of entries as the number of the available blocks and not decoding the selection information when the number of the available blocks is 1;

5

selecting a selected block from the available blocks according to the selection information; and

decoding the to-be-decoded block by using a motion vector of the selected block.

10

According to a further aspect of the present invention there is provided a video decoding apparatus comprising: processing circuitry configured to:

15

acquire one or more available blocks having a motion vector from decoded blocks adjacent to a to-be-decoded block and a number of the available blocks;

select a code table from a plurality of code tables depending on the number of the available blocks;

20

decode selection information specifying one of the available blocks using the selected code table, the selected code table including indexes and code words corresponding to the indexes, wherein a number of the indexes is equal to the number of the available blocks, and when the number of the available blocks is 1, the selection information is not decoded;

25

select a block from the available blocks according to the selection information; and

decode the to-be-decoded block by using a motion vector of the selected block.

30

According to a further aspect of the present invention there is provided a video decoding method comprising:

acquiring one or more available blocks having a motion vector from decoded blocks adjacent to a to-be-decoded block and a number of the available blocks;

5 selecting a code table from a plurality of code tables depending on the number of the available blocks;

10 decoding selection information specifying one of the available blocks using the selected code table, the selected code table including indexes and code words corresponding to the indexes, wherein a number of the indexes is equal to the number of the available blocks, and when the number of the available blocks is 1, the selection information is not decoded;

selecting a block from the available blocks according to the selection information; and

15 decoding the to-be-decoded block by using a motion vector of the selected block.

20 According to a further aspect of the present invention there is provided a video decoding apparatus comprising a computer constructed and arranged to:

acquire one or more available blocks having a motion vector from decoded blocks adjacent to a to-be-decoded block and a number of the available blocks;

25 select a code table from a plurality of code tables depending on the number of the available blocks;

30 decode selection information specifying one of the available blocks using the selected code table, the selected code table including indexes and code words corresponding to the indexes, wherein a number of the indexes is equal to the number of the available blocks, and when the number of the available blocks is 1, the selection information is not decoded;

select a block from the available blocks according to the selection information; and

decode the to-be-decoded block by using a motion vector of the selected block.

5

According to an aspect of the present invention there is provided a video decoding apparatus comprising:

processing circuitry configured to:

acquire one or more available blocks having a motion  
10 vector from decoded blocks adjacent to a to-be-decoded block  
and a number of the available blocks;

select a first block from the one or more available  
blocks;

select a plurality of code words based on the number of  
15 the available blocks; and

decode selection information specifying the first block  
from the one or more available blocks using a code table  
corresponding to the first block from the one or more  
available blocks, the code table including index and code  
20 words corresponding to the index, and the to-be-decoded block  
by using a motion vector of the first block, wherein a number  
of the index is determined depending on the number of the  
available blocks.

25 According to another aspect of the present invention  
there is provided a video decoding method comprising:

acquiring one or more available blocks having a motion  
vector from decoded blocks adjacent to a to-be-decoded block  
and a number of the available blocks;

selecting a first block from the one or more available blocks;

selecting a plurality of code words based on the number of the available blocks; and

5        decoding selection information specifying the first block from the one or more available blocks using a code table corresponding to the first block from the one or more available blocks, the code table including index and code words corresponding to the index, and the to-be-decoded block  
10 by using a motion vector of the first block, wherein a number of the index is determined depending on the number of the available blocks.

According to a further aspect of the present invention  
15 there is provided a non-transitory computer readable medium including computer executable instructions, wherein the instructions, when executed by a processor, cause the processor to perform a method comprising:

acquiring one or more available blocks having a motion  
20 vector from decoded blocks adjacent to a to-be-decoded block and a number of the available blocks;

selecting a first block from the one or more available blocks;

selecting a plurality of code words based on the number  
25 of the available blocks; and

decoding selection information specifying the first block from the one or more available blocks using a code table corresponding to the first block from the one or more available blocks, the code table including index and code  
30 words corresponding to the index, and the to-be-decoded block

by using a motion vector of the first block, wherein a number of the index is determined depending on the number of the available blocks.

5           According to a further aspect of the present invention there is provided a video encoding apparatus comprising:  
          processing circuitry configured to:  
          acquire one or more available blocks having a motion  
          vector from encoded blocks adjacent to a to-be-encoded block  
10   and a number of the available blocks;  
          select a first block from the one or more available  
          blocks;  
          select a plurality of code words based on the number of  
          the available blocks; and  
15           encode selection information specifying the first block  
          from the one or more available blocks using a code table  
          corresponding to the first block from the one or more  
          available blocks, the code table including index and code  
          words corresponding to the index, and the to-be-encoded block  
20   by using a motion vector of the first block, wherein a number  
          of the index is determined depending on the number of the  
          available blocks.

          According to a further aspect of the present invention  
25   there is provided a video encoding method comprising:  
          acquiring one or more available blocks having a motion  
          vector from encoded blocks adjacent to a to-be-encoded block  
          and a number of the available blocks;  
          selecting a first block from the one or more available  
30   blocks;

selecting a plurality of code words based on the number of the available blocks; and

encoding selection information specifying the first block from the one or more available blocks using a code table  
5 corresponding to the first block from the one or more available blocks, the code table including index and code words corresponding to the index, and the to-be-encoded block by using a motion vector of the first block, wherein a number of the index is determined depending on the number of the  
10 available blocks.

According to a further aspect of the present invention there is provided a non-transitory computer readable medium including computer executable instructions, wherein the  
15 instructions, when executed by a processor, cause the processor to perform a method comprising:

acquiring one or more available blocks having a motion vector from encoded blocks adjacent to a to-be-encoded block and a number of the available blocks;

20 selecting a first block from the one or more available blocks;

selecting a plurality of code words based on the number of the available blocks; and

encoding selection information specifying the first block  
25 from the one or more available blocks using a code table corresponding to the first block from the one or more available blocks, the code table including index and code words corresponding to the index, and the to-be-encoded block by using a motion vector of the first block, wherein a number

of the index is determined depending on the number of the available blocks.

According to a further aspect of the present invention there is provided a video decoding apparatus comprising:  
5 an acquisition module configured to acquire available blocks having motion vectors and a number of the available blocks from decoded blocks adjacent to a to-be-decoded block, wherein when a block size of a decoded block having a motion  
10 vector is a specific size, the decoded block is not determined as the available block;  
a selection information decoding module configured to decode selection information specifying an available block using a code table corresponding to the number of the  
15 available blocks;  
a selection module configured to select one available block from the available blocks according to the selection information; and  
an image decoding module configured to subject the to-be-  
20 decoded block to motion compensated prediction decoding using a motion vector of the selected available block.

According to a further aspect of the present invention there is provided a video decoding method comprising:  
25 acquiring available blocks having motion vectors and a number of the available blocks from decoded blocks adjacent to a to-be-decoded block, wherein when a block size of a decoded block having a motion vector is a specific size, the decoded block is not determined as the available block;

decoding selection information specifying an available block using a code table corresponding to the number of the available blocks;

5 selecting one available block from the available blocks according to the selection information; and

subjecting the to-be-decoded block to motion compensated prediction decoding using a motion vector of the selected available block.

10 According to a further aspect of the present invention there is provided a video encoding apparatus comprising:

an acquisition module configured to acquire available blocks having motion vectors and a number of the available blocks from encoded blocks adjacent to a to-be-encoded block,  
15 wherein when a block size of an encoded block having a motion vector is a specific size, the encoded block is not determined as the available block;

a selection module configured to select one available block from the available blocks;

20 a selection information encoding module configured to encode selection information specifying the available block using a code table corresponding to the number of the available blocks; and

an image encoding module configured to subject the to-be-  
25 encoded block to motion compensated prediction encoding using a motion vector of the selected available block.

According to a further aspect of the present invention there is provided a video encoding method comprising:

acquiring available blocks having motion vectors and a number of the available blocks from encoded blocks adjacent to a to-be-encoded block, wherein when a block size of an encoded block having a motion vector is a specific size, the encoded  
5 block is not determined as the available block;  
selecting one available block from the available blocks;  
encoding selection information specifying the available block using a code table corresponding to the number of the available blocks; and  
10 subjecting the to-be-encoded block to motion compensated prediction encoding using a motion vector of the selected available block.

#### Brief Description of Drawings

15 FIG. 1 is a block diagram of a video encoding

apparatus related to an embodiment of the present invention.

FIG. 2 is a flowchart representing a processing procedure of the video encoding apparatus.

5 FIG. 3 is a flowchart representing a processing procedure of an acquisition /selection module.

FIG. 4A is a diagram for describing a discrimination method based on a block size.

10 FIG. 4B is a diagram for describing a discrimination method based on a block size.

FIG. 4C is a diagram for describing a discrimination method based on a block size.

15 FIG. 5 is a diagram for describing a discrimination method by a unidirectional or a bidirectional.

FIG. 6 is a flowchart representing a processing procedure of a selection information encoder.

FIG. 7 shows an example of an index of selection information.

20 FIG. 8 shows an example of a code table of selection information.

FIG. 9 is a schematic view of a syntax structure.

FIG. 10 shows a data structure of a macroblock layer.

25 FIG. 11 shows a block diagram of a video decoding apparatus related to the embodiment of the present invention.

FIG. 12 shows a flowchart representing a processing procedure of the video decoding apparatus.

#### Mode for Carrying Out the Invention

There will now be explained embodiments of the present invention referring to drawings.

A video encoding apparatus related to an embodiment is described with reference to FIG. 1 hereinafter. A subtracter 101 calculates a difference between an input video signal 11 and a predictive coded video signal 15, and outputs a prediction error signal 12. The output terminal of the subtracter 101 is connected to a variable length encoder 111 through an orthogonal transformer 102 and a quantizer 103. The orthogonal transformer 102 orthogonal-transforms a prediction error signal 12 from the subtracter 101, and the quantizer 103 quantizes an orthogonal transformation coefficient and outputs quantization orthogonal transformation coefficient information 13. The variable length encoder 111 performs variable length encoding on the quantization orthogonal transformation coefficient information 13 from the quantizer 103.

The output terminal of the quantizer 103 is connected to an adder 106 through a dequantizer 104 and an inverse orthogonal transformer 105. The dequantizer 104 dequantizes the quantized orthogonal transformation coefficient information 13, and converts it in an

orthogonal transformation coefficient. The inverse orthogonal transformer 105 converts the orthogonal transformation coefficient to a prediction error signal. The adder 106 adds the prediction error signal of the inverse orthogonal transformer 105 and the predictive coded video signal 15 to generate a local decoded image signal 14. The output terminal of the adder 106 is connected to a motion compensated prediction module 108 through a frame memory 107.

The frame memory 107 accumulates a local decoded image signal 14. A setting module 114 sets a motion compensated prediction mode (a prediction mode) of a to-be-encoded block. The prediction mode includes a unidirectional prediction using a single reference picture and a bidirectional prediction using two reference pictures. The unidirectional prediction includes L0 prediction and L1 prediction of AVC. A motion compensated prediction module 108 comprises a prediction module 109 and an acquisition/selection module 110.

The acquisition/selection module 110 acquires available blocks having motion vectors and the number of the available blocks from encoded blocks adjacent to the to-be-encoded block, and selects a selection block from the available blocks. The motion compensated prediction module 108 performs a prediction using a local decoded image signal 14 stored in the frame memory 107 as a reference image and

generates a predictive coded video signal 15. The acquisition/selection module 110 selects one block (a selection block) from the adjacent blocks adjacent to the to-be-encoded block. For example, the block having an appropriate motion vector among the adjacent blocks is selected as the selection block. The acquisition/selection module 110 selects the motion vector of the selection block as a motion vector 16 to be used for the motion compensated prediction, and sends it to the prediction module 109. In addition, the acquisition/selection module 110 generates selection information 17 of the selection block and sends it to the variable length encoder 111.

The variable length encoder 111 has a selection information encoder 112. The selection information encoder 112 subjects the selection information 17 to variable length encoding while switching a code table so as to have therein the same number of entries as the available blocks of encoded blocks. The available block is a block having a motion vector among encoded blocks adjacent to the to-be-encoded block. A multiplexer 113 multiplexes quantized orthogonal transformation coefficient information and selection information and output encoded data.

The action of the video encoding apparatus of the above configuration will be described referring to the flowchart of FIG. 2.

At first a prediction error signal 12 is generated (S11). In generation of this prediction error signal 12, a motion vector is selected, and a prediction image is generated using the selected motion vector. The subtracter 101 calculates a difference between the signal of the prediction image, that is, the prediction image signal 15 and the input video signal 11 to generate the prediction error signal 12.

The orthogonal transformer 102 orthogonal-transforms the prediction error signal 12 to generate an orthogonal transformed coefficient (S12). The quantizer 103 quantizes the orthogonal transformed coefficient (S13). The dequantizer 104 dequantizes the quantized orthogonal transformed coefficient information (S14), and then subjects it to inverse orthogonal transform to provide a reproduced prediction error signal (S15). The adder 106 adds the reproduced prediction error signal and the predictive coded video signal 15 to generate a local decoded image signal 14 (S16). The local decoded image signal 14 is stored in the frame memory 107 (as a reference picture) (S17), and the local decoded image signal read from the frame memory 107 is inputted to the motion compensated prediction module 108.

The prediction module 109 of the motion compensated prediction module 108 subjects the local decoded image signal (reference image) to motion

compensated prediction using the motion vector 16 to generate the predictive coded video signal 15. The predictive coded video signal 15 is sent to the subtracter 101 to calculate a difference with respect to the input video signal 11, and further is sent to the adder 106 to generate the local decoded image signal 14.

The acquisition/selection module 110 selects a selection block from adjacent blocks, generates selection information 17, and sends a motion vector 16 of the selection block to the prediction module 109 which performs the motion compensated prediction using the motion vector of the selection block. The selection information 17 is sent to the selection information encoder 112. When the selection block is selected from the adjacent blocks, the adjacent block having the appropriate motion vector allowing the amount of encoded bits to be decreased is selected.

The orthogonal transformation coefficient information 13 quantized with the quantizer 103 also is input to the variable length encoder 111 and is subjected to variable length coding (S18). The acquisition/selection module 110 outputs the selection information 16 used for motion compensated prediction, and inputs it to the selection information encoder 112. The selection information encoder 112 switches the code table so as to have therein the same number of entries as the available blocks of the encoded blocks neighboring the to-be-encoded block and having motion

vectors, and the selection information 17 is subjected to variable length coding. The multiplexer 113 multiplexes the quantized orthogonal transformation coefficient information from the variable length encoder 111 and the selection information to output a bit stream of coded data 18 (S19). The coded data 18 is sent to a storage system (not shown) or a transmission path.

In the flowchart of FIG. 2, the flow of steps S14 to S17 may be replaced by the flow of steps S18 and S19.

In other words, the variable length coding step S18 and multiplexing step S19 may be executed following the quantization step S13, and the dequantizing step S14 to the storage step S17 may be executed following the multiplexing step S19.

The action of the acquisition/selection module 110 will be described referring to flowchart shown in FIG. 3.

At first the available block candidates being the encoded blocks neighboring the to-be-encoded block and having motion vectors are searched for (S101). When the available block candidates are searched for, the block size for motion compensated prediction of these available block candidates is determined (S102). Next, it is determined whether the available block candidates are a unidirectional prediction or a bidirectional

prediction (S103). An available block is extracted from the available block candidates based on the determined result and the prediction mode of the to-be-encoded block. One selection block is selected for from the extracted available  
5 blocks, and information specifying the selection block is acquired as selection information (S104).

There will be described a process for determining a block size referring to FIGS. 4A to 4C (S102).

The adjacent blocks used in the present embodiment are  
10 assumed to be blocks, which are positioned at the left, upper left, upper and upper right of the to-be-encoded block. Therefore, when the to-be-encoded block positions the most upper left of the frame, this to-be-encoded block cannot be applied to the present invention because there is  
15 not the available block adjacent to the to-be-encoded block. When the to-be-encoded block is on the upper end of the screen, the available block is only a left block, and when the to-be-encoded block is on the extreme left and not on the extreme upper end, the two blocks of the to-be-encoded  
20 blocks which position the upper and upper right thereof.

When the block size is a size 16x16, the block sizes for motion compensated prediction of the adjacent blocks are four kinds of size 16x16, size 16x8, size 8x16 and size 8x8 as shown in FIGS. 4A to 4C.  
25 Considering these four kinds, the adjacent blocks that

may be available blocks are 20 kinds as shown in  
FIGS. 4A to 4C. In other words, there are four kinds  
for size 16x16 as shown in FIG. 4A, 10 kinds for size  
16x8 as shown in FIG. 4B, and six kinds for size 8x8 as  
5 shown in FIG. 4C. In discrimination of the block size  
(S102), the available block is searched for according  
to the block size from 20 kinds of blocks. For  
example, when the size of the available block is  
assumed to be only size 16x16, the available blocks  
10 determined by this block size are four kinds of blocks  
of size 16x16 as shown in FIG. 4A. In other words, the  
available blocks are a block on the upper left side of  
the to-be-encoded block, a block on the upper side of  
the to-be-encoded block, and a block on the left side  
15 of the to-be-encoded block and a block on the upper  
right side of the to-be-encoded block. In addition,  
even if the macroblock size was expanded not less than  
size 16x16, it can be the available block similarly to  
the macroblock size of 16x16. For example, when the  
20 macroblock size is 32x32, the block size for motion  
compensated prediction of the adjacent block are  
four kinds of size 32x32, size 32x16, size 16x32, and  
size 16x16, and the adjacent blocks that may be the  
available blocks are 20 kinds.

25 There will be described the determination of the  
unidirectional prediction or bidirectional prediction  
which is executed by the acquisition/selection module

110 (S103) with reference to FIG. 5.

For example, the block size is limited to 16x16, and the unidirectional or bidirectional prediction of the adjacent block with respect to the to-be-encoded  
5 block is assumed to be a case as shown in FIG. 5. In discrimination of the unidirectional or bidirectional prediction (S103), the available block is searched for according to the direction of prediction. For example, the adjacent block having a prediction direction L0 is  
10 assumed to be an available block determined in the prediction direction. In other words, the upper, left and upper right blocks of the to-be-encoded blocks shown in FIG. 5 (a) are available blocks determined in the prediction direction. In this case, the upper left  
15 block of the to-be-encoded blocks is not employed. When the adjacent block including the prediction direction L1 is assumed to be the available block determined in the prediction direction, the upper left and upper blocks of the to-be-encoded blocks shown in  
20 FIG. 5 (b) are available blocks determined in the prediction direction. In this case, the left and upper right blocks of the to-be-encoded blocks are not employed. When the adjacent block including the prediction direction L0/L1 is assumed to be the  
25 available block determined in the prediction direction, only the upper block of the to-be-encoded blocks shown in FIG. 5 (c) is the available block determined in the

prediction direction. In this case, the left, upper  
left and upper right blocks of the to-be-encoded blocks  
are not employed. In addition, the prediction  
direction L0 (L1) corresponds to the prediction  
5 direction of the L0 prediction (L1 prediction) in AVC.

There will be described the selection information  
encoder 112 referring to flowchart shown in FIG. 6.

The available block of the encoded block having a  
motion vector is searched for from among adjacent  
10 blocks adjacent to the to-be-encoded block, and the  
available block information determined by the block  
size and the unidirectional or bidirectional prediction  
is acquired (S201). The code tables corresponding to  
the number of available blocks as shown in FIG. 8 are  
15 switched using this available block information (S202).  
The selection information 17 sent from the  
acquisition/selection module 110 is subjected to  
variable length coding using a changed code table  
(S203).

20 An example of an index of selection information is  
explained referring to FIG. 7 next.

When there is no available block as shown in  
FIG. 7 (a), the selection information is not sent  
because the present invention is inapplicable to this  
25 block. When there is one available block as shown in  
FIG 7 (b), the selection information is not sent  
because a motion vector of an available block used for

motion compensation of the to-be-encoded block is determined in unique. When there are two available blocks as shown in FIG. 7 (c), the selection information of an index 0 or 1 is sent. When there are three available blocks as shown in FIG. 7 (d), the selection information of an index 0, 1 or 2 is sent. When there are four available blocks as shown in FIG. 7 (e), the selection information of an index 0, 1, 2 or 3 is sent.

In addition, as an example of setting an index of the available block, an example of setting the index to the available block in order of the left, upper left, upper and upper right of the to-be-encoded blocks is shown in FIG. 7. In other words, the index is set to the block to be used except for the block which is not used.

There will be described a code table of the selection information 17 referring to FIG. 8 next.

The selection information encoder 112 switches the code table according to the number of available blocks (S202). As mentioned above, when there are two or more available blocks, the selection information 17 must be encoded.

At first when there are two available blocks, indexes 0 and 1 are needed, and the code table is indicated by the table on the left side of FIG. 8. When there are three available blocks, indexes 0, 1 and

2 are needed, and the code table is indicated by the table on the center of FIG. 8. When there are four available blocks, indexes 0, 1, 2, 3 are needed, and the code table is indicated by the table on the right side of FIG. 8. These code tables are switched according to the number of available blocks.

There will be explained an encoding method of the selection information.

FIG. 9 shows a schematic diagram of a structure of syntax used in this embodiment.

The syntax comprises mainly three parts, wherein High Level Syntax 801 is filled with syntax information of the upper layer not less than a slice. Slice Level Syntax 804 specifies information necessary for every slice, Macroblock Level Syntax 807 specifies a variable length coded error signal or mode information which is needed for every macroblock.

These syntaxes each comprise more detailed syntaxes. The High Level Syntax 801 comprises syntaxes of sequence and picture levels such as Sequence parameter set syntax 802 and Picture parameter set syntax 803. Slice Level Syntax 804 comprises Slice header syntax 405, Slice data syntax 406 and so on. Further, Macroblock Level Syntax 807 comprises macroblock layer syntax 808, macroblock prediction syntax 809 and so on.

The syntax information necessary for this

embodiment is macroblock layer syntax 808. The syntax is described hereinafter.

The "available\_block\_num" shown in FIG. 10 (a) and (b) indicates the number of available blocks. When this is two or more, it is necessary to encode the selection information. In addition, the "mvcopy\_flag" indicates a flag representing whether the motion vector of the available block is used in the motion compensated prediction. When there are one or more available blocks and the flag is "1", the motion vector of the available block can be used in the motion compensated prediction. Further, the "mv\_select\_info" indicates the selection information, and the code table is as described above.

FIG. 10 (a) shows a syntax when selection information is encoded after "mb\_type." When, for example, the block size is only size 16x16, the "mvcopy\_flag and mv\_select\_info" needs not be encoded if the "mb\_type" is other than 16x16. If mb\_type is 16x16, mvcopy\_flag and mv\_select\_info are encoded.

FIG. 10 (b) shows a syntax when selection information is encoded before mb\_type. If, for example, mvcopy\_flag is 1, it is not necessary to encode mb\_type. If mv\_copy\_flag is 0, mb\_type is encoded.

In this embodiment, what order may be employed in a scan order for encoding. For example, a line scan or

a Z scan is applicable to the present invention.

There will be a video decoding apparatus related to another embodiment with reference to FIG. 11.

The coded data 18 output from the video encoding  
5 apparatus of FIG. 1 is input to a demultiplexer 201 of  
the video decoding apparatus as encoded data 21 to be  
decoded through a storage system or a transmission  
system. The demultiplexer 201 demultiplexes the  
10 encoded data 21 to separate the encoded data 21 into  
quantization orthogonal transformation coefficient  
information and selection information. The output  
terminal of the demultiplexer 201 is connected to a  
variable length decoder 202. The variable length  
15 decoder 202 decodes the quantization orthogonal  
transformation coefficient information and the  
selection information. The output terminal of the  
variable length decoder 202 is connected to an adder  
206 via a dequantizer 204 and an inverse orthogonal  
20 transformer 205. The dequantizer 204 dequantizes the  
quantized orthogonal transformation coefficient  
information to transform it to an orthogonal  
transformation coefficient. The inverse orthogonal  
transformer 205 subjects the orthogonal transformation  
coefficient to inverse orthogonal transform to generate  
25 a prediction error signal. The adder 206 adds the  
prediction error signal to the predictive coded video  
signal from a prediction image generator 207 to produce

a video signal.

The prediction image generator 207 includes a prediction module 208 and an acquisition/selection module 209. The acquisition/selection module 209 selects a  
5 selection block from available blocks using selection information 23 decoded by the selection information decoder 203 of the variable length decoder 202 and sends a motion vector 25 of the selection block to a prediction module 208. The prediction module 208 motion-compensates a reference  
10 image stored in a frame memory 210 by the motion vector 25 to produce a prediction image.

The action of the video decoding apparatus of the above configuration will be described referring to flowchart of FIG. 12.

15 The demultiplexer 201 demultiplexes the coded data 21 (S31), and the variable length decoder 202 decodes it to produce quantized orthogonal transformation coefficient information 22 (S32). In addition, the selection information decoder 203 checks the condition of the adjacent block  
20 adjacent to a to-be-decoded block and decode it by switching code tables according to the number of the available blocks of the adjacent encoded blocks having motion vectors as shown in FIG. 8, similarly to the selection information encoder 112 of the encoding apparatus, thereby to produce  
25 the selection information 23 (S33).

The quantized orthogonal transformation coefficient information 22 that is information output from the variable length decoder 202 is sent to the dequantizer 204, and the selection information 23 which is information output from selection information decoder 203 is sent to the acquisition/selection module 209.

The quantization orthogonal transformation coefficient information 22 is dequantized with the dequantizer 204 (S34), and then subjected to inverse orthogonal transform with the inverse orthogonal transformer 205 (S35). As a result, the prediction error signal 24 is obtained. The adder 206 adds the prediction image signal to the prediction error signal 24 to reproduce a video signal 26 (S36). The reproduced video signal 27 is stored in the frame memory 210 (S37).

The prediction image generator 207 generates the prediction image 26 using the motion vector of the available block that is the decoded block neighboring the to-be-decoded block and having a motion vector, the motion vector being a motion vector of a selection block selected on the basis of the decoded selection information 23. The acquisition/selection module 209 selects one motion vector from the adjacent blocks on the basis of the available block information of the adjacent block and the selection information 23 decoded with the selection information decoder 203, similarly to the acquisition/selection module 110 of the coding apparatus. The prediction module 208 generates the

prediction image 26 using this selected motion vector 25, and sends it to the adder 206 to produce a video signal 27.

5 According to the present invention, encoding the selection information according to the number of available blocks allows the selection information to be sent using a suitable code table, resulting in that additional information of the selection information can be reduced.

10 In addition, using the motion vector of the available block for the motion compensated prediction of the to-be-encoded block allows the additional information on the motion vector information to be reduced.

15 Furthermore, the motion vector calculation method is not fixed and improves degrees of freedom of motion vector calculation as compared with a direct mode by selecting an appropriate one from among the available blocks.

20 The technique of the present invention recited in the embodiment of the present invention may be executed with a computer and also may be distributed as a program capable of causing a computer to execute by storing it in a recording medium such as a magnetic  
25 disk (flexible disk, a hard disk, etc.), an optical disk (CD-ROM, DVD, etc.), a semiconductor memory, etc.

In addition, the present invention is not limited

to the above embodiments and may be modified in component within a scope without departing from the subject matter of the invention.

5 In addition, it is possible to provide various inventions by combining appropriately a plurality of components disclosed in the above embodiments. For example, some components may be deleted from all components shown in the embodiments. Further, the components of different embodiments may be combined  
10 appropriately.

#### Industrial Applicability

The apparatus of the present invention is applied to an image compression process in a communication, a storage and a broadcast.

The embodiments of the invention in which an exclusive property or privilege is claimed are defined as follows:

1. A video decoding apparatus comprising:

an acquisition module configured to acquire available blocks having motion vectors and a number of the available blocks from decoded blocks adjacent to a to-be-decoded block, wherein when a block size of a decoded block having a motion vector is a specific size, the decoded block is not determined as the available block;

a selection information decoding module configured to decode selection information specifying an available block using a code table corresponding to the number of the available blocks;

a selection module configured to select one available block from the available blocks according to the selection information; and

an image decoding module configured to subject the to-be-decoded block to motion compensated prediction decoding using a motion vector of the selected available block.

2. A video decoding method comprising:

acquiring available blocks having motion vectors and a number of the available blocks from decoded blocks adjacent to a to-be-decoded block, wherein when a block size of a decoded block having a motion vector is a specific size, the decoded block is not determined as the available block;

decoding selection information specifying an available block using a code table corresponding to the number of the available blocks;

selecting one available block from the available blocks according to the selection information; and

subjecting the to-be-decoded block to motion compensated prediction decoding using a motion vector of the selected available block.

3. A video encoding apparatus comprising:

an acquisition module configured to acquire available blocks having motion vectors and a number of the available blocks from encoded blocks adjacent to a to-be-encoded block, wherein when a block size of an encoded block having a motion vector is a specific size, the encoded block is not determined as the available block;

a selection module configured to select one available block from the available blocks;

a selection information encoding module configured to encode selection information specifying the available block using a code table corresponding to the number of the available blocks; and

an image encoding module configured to subject the to-be-encoded block to motion compensated prediction encoding using a motion vector of the selected available block.

4. A video encoding method comprising:

acquiring available blocks having motion vectors and a number of the available blocks from encoded blocks adjacent to a to-be-encoded block, wherein when a block size of an encoded block having a motion vector is a specific size, the encoded block is not determined as the available block;

selecting one available block from the available blocks;

encoding selection information specifying the available block using a code table corresponding to the number of the available blocks; and

subjecting the to-be-encoded block to motion compensated prediction encoding using a motion vector of the selected available block.

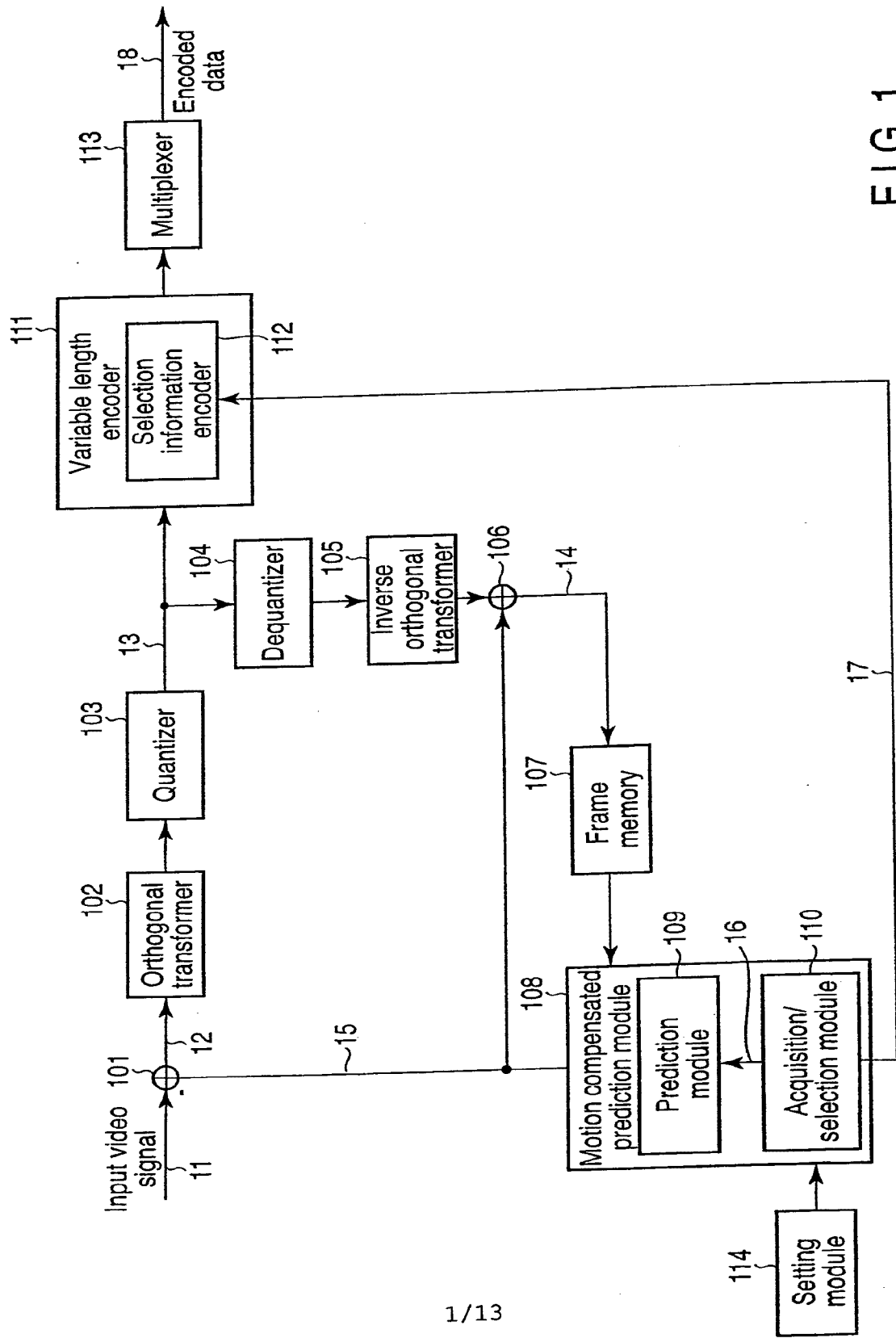

FIG. 1

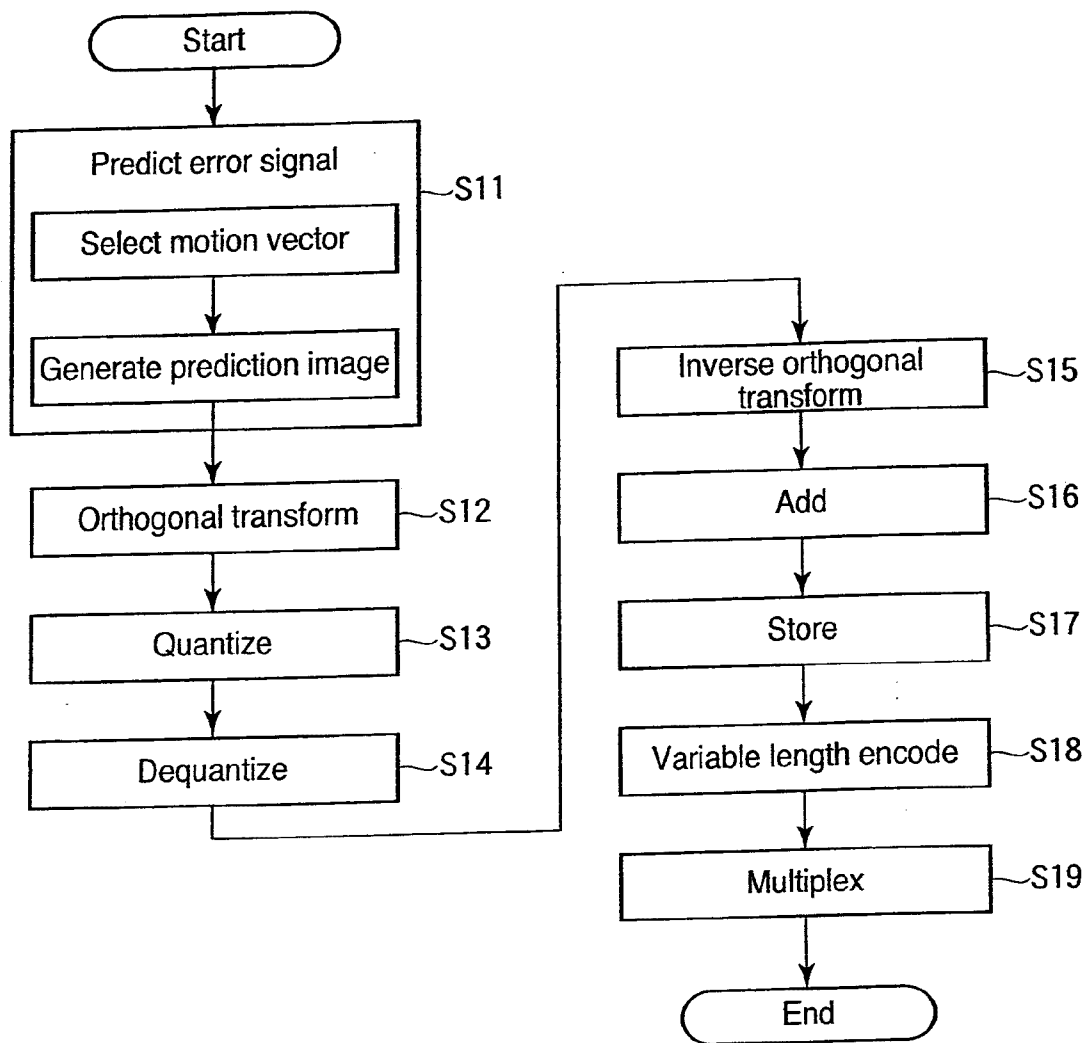

FIG. 2

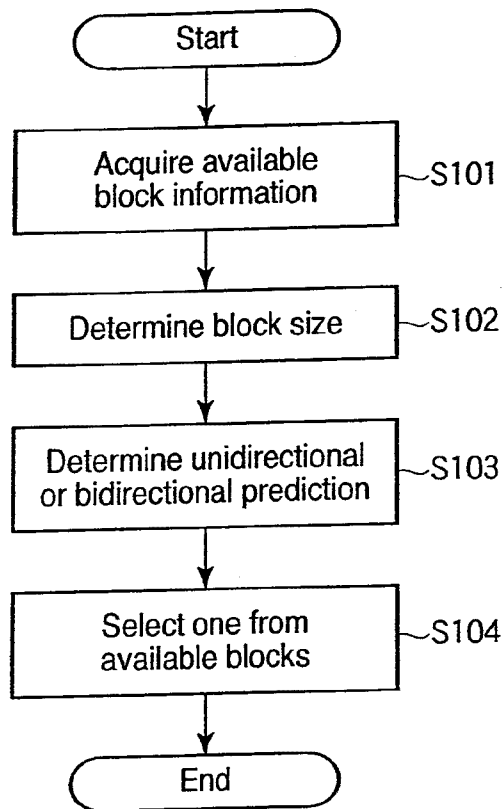

FIG. 3

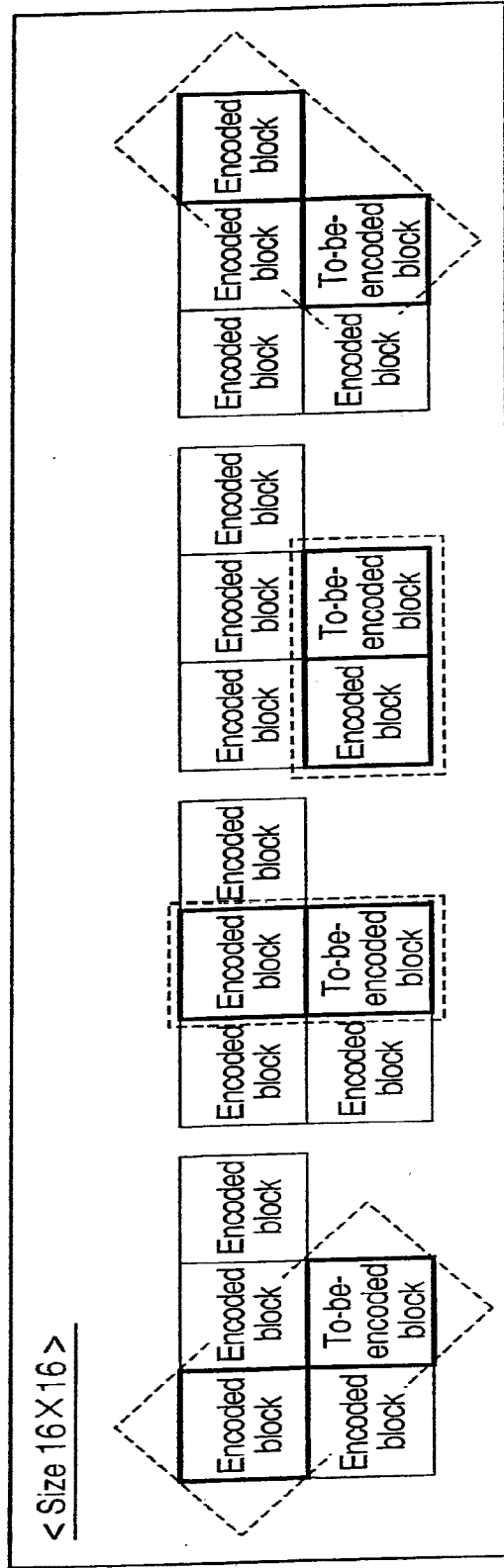

FIG. 4A

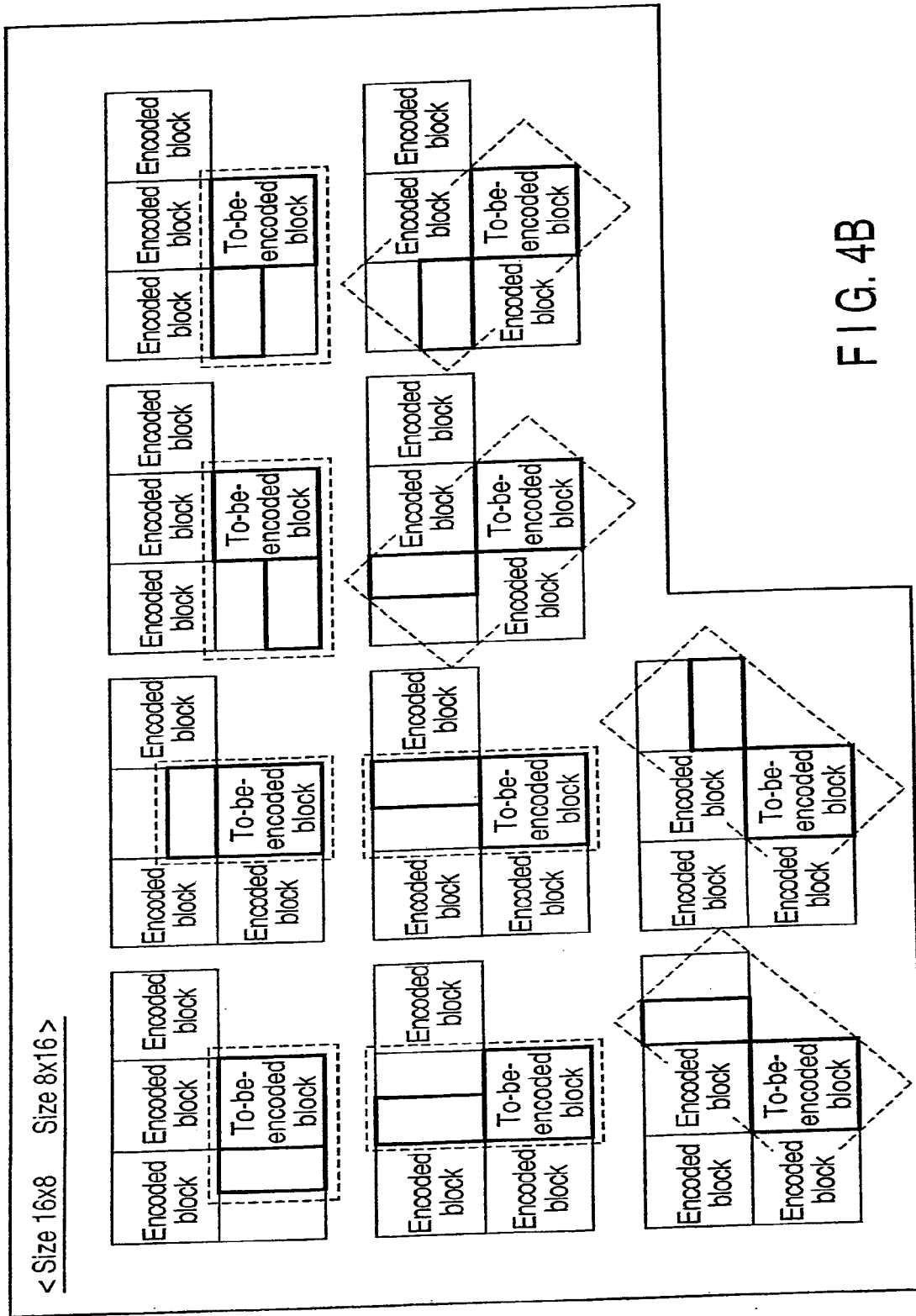

FIG. 4B

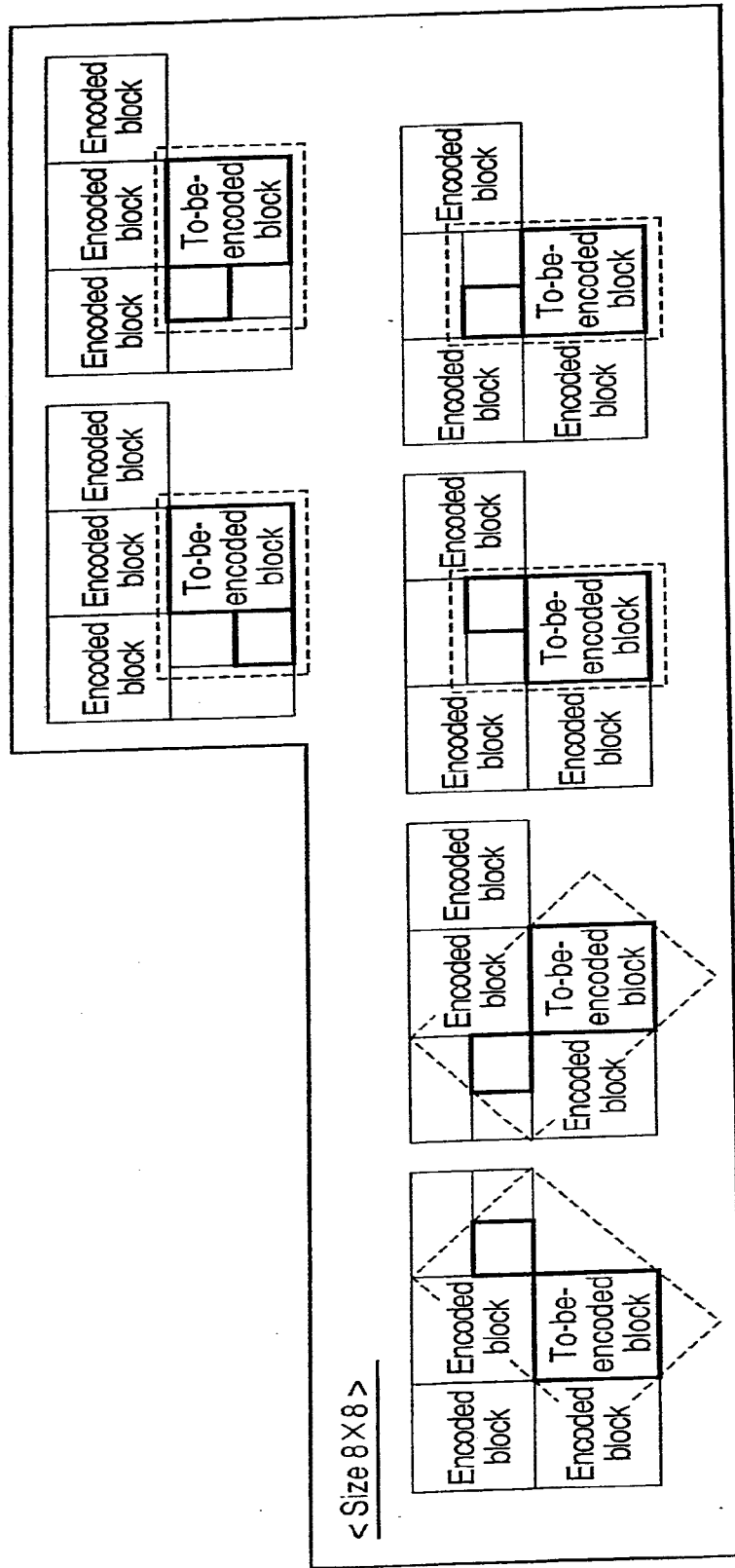

FIG. 4C

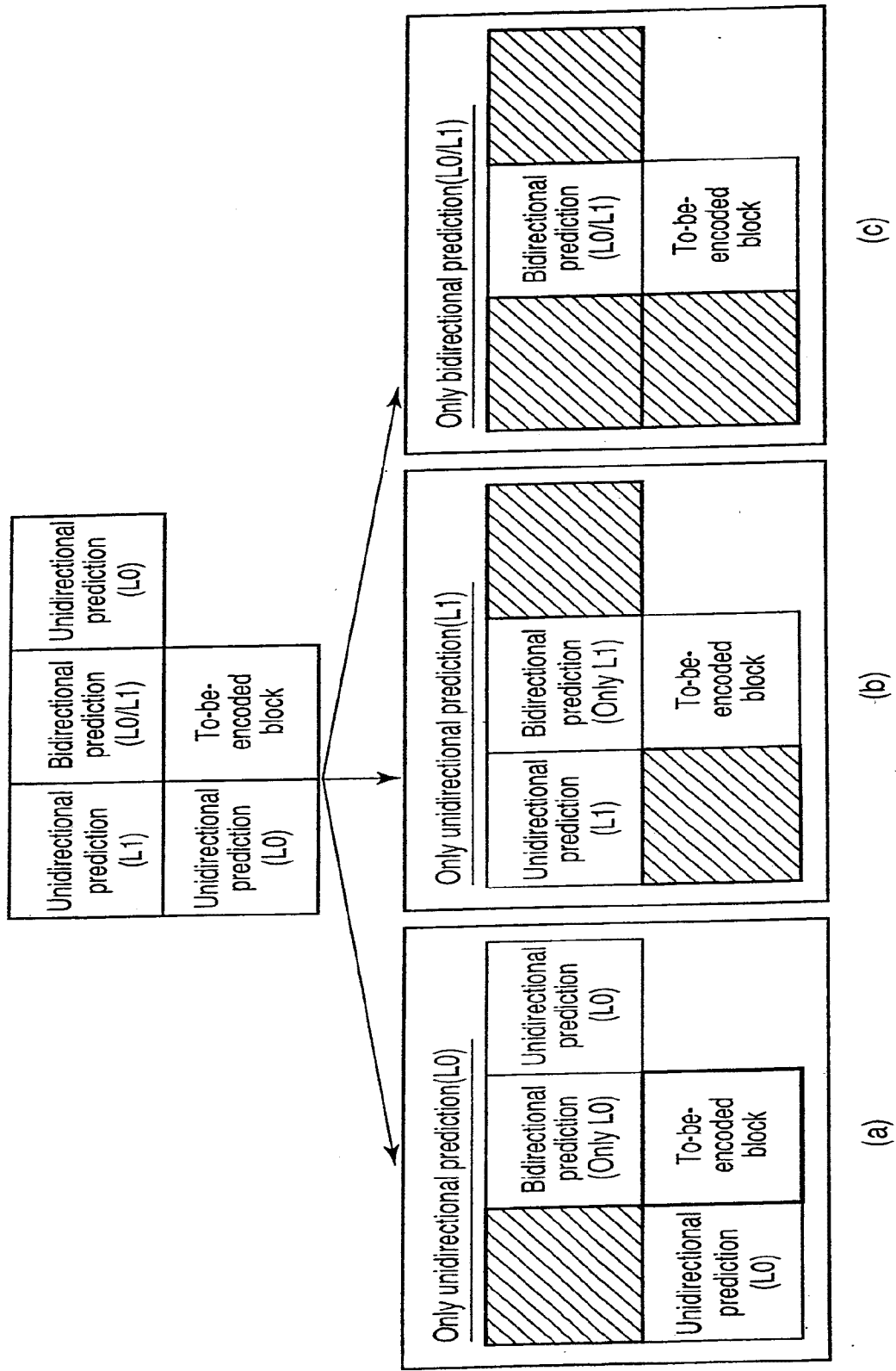

FIG. 5

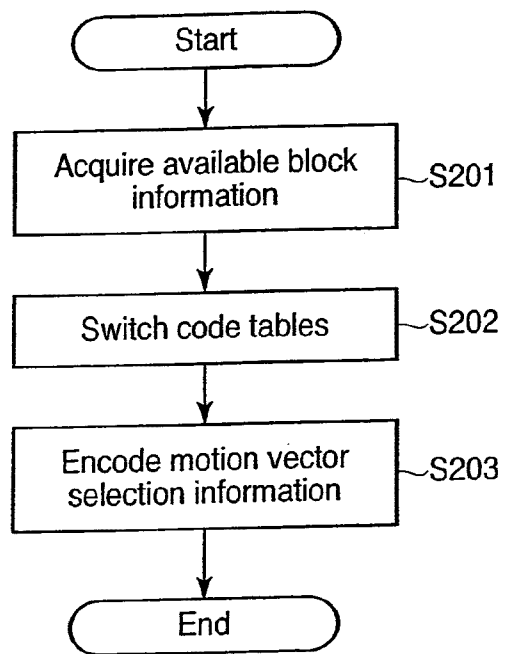

FIG. 6

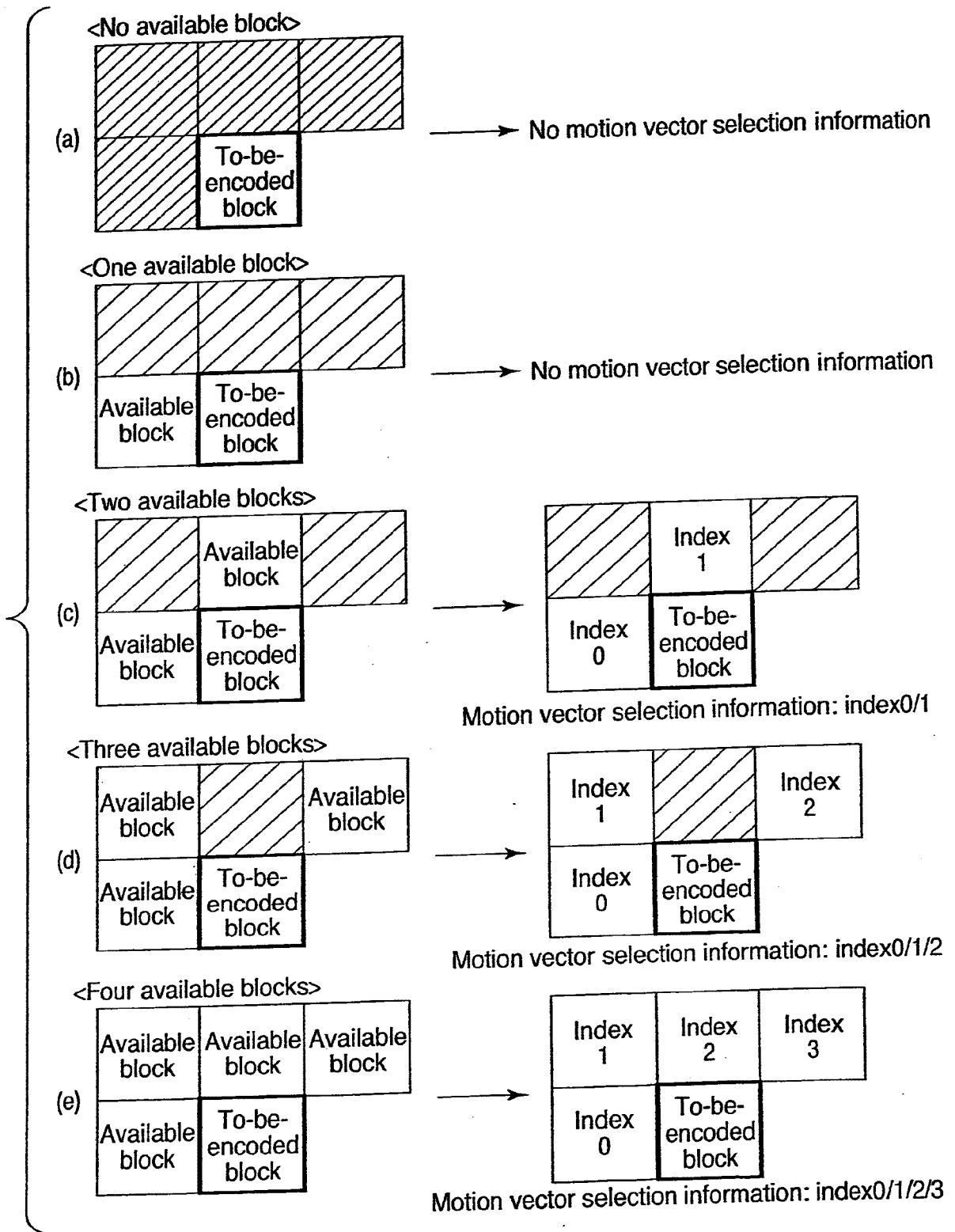

FIG. 7

<Two available blocks>		<Three available blocks>		<Four available blocks>	
Index	Code word	Index	Code word	Index	Code word
0	0	0	0	0	0
1	1	1	10	1	10
		2	11	2	110
				3	111

FIG. 8

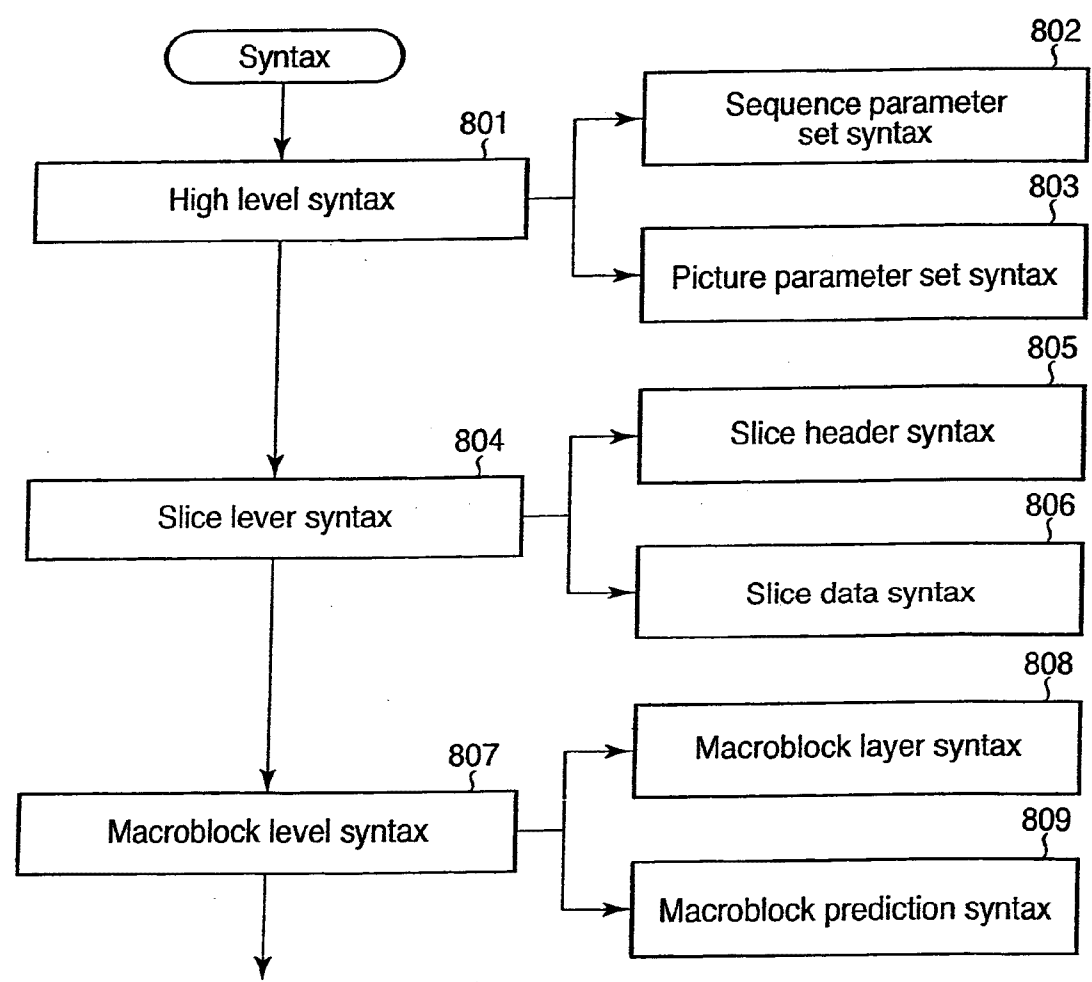

FIG. 9

```
Macroblock_layer( {  
  mb_type  
  if (available_block_num>0)  
    mv_copy_flag  
  if (mvcopy_flag && available_block_num>1)  
    mv_select_info  
  ...  
}
```

(a)

```
Macroblock_layer( {  
  if (available_block_num>0)  
    mv_copy_flag  
  if (mvcopy_flag && available_block_num>1)  
    mv_select_info  
  if (mvcopy_flag == 0)  
    mb_type  
  ...  
}
```

(b)

FIG. 10

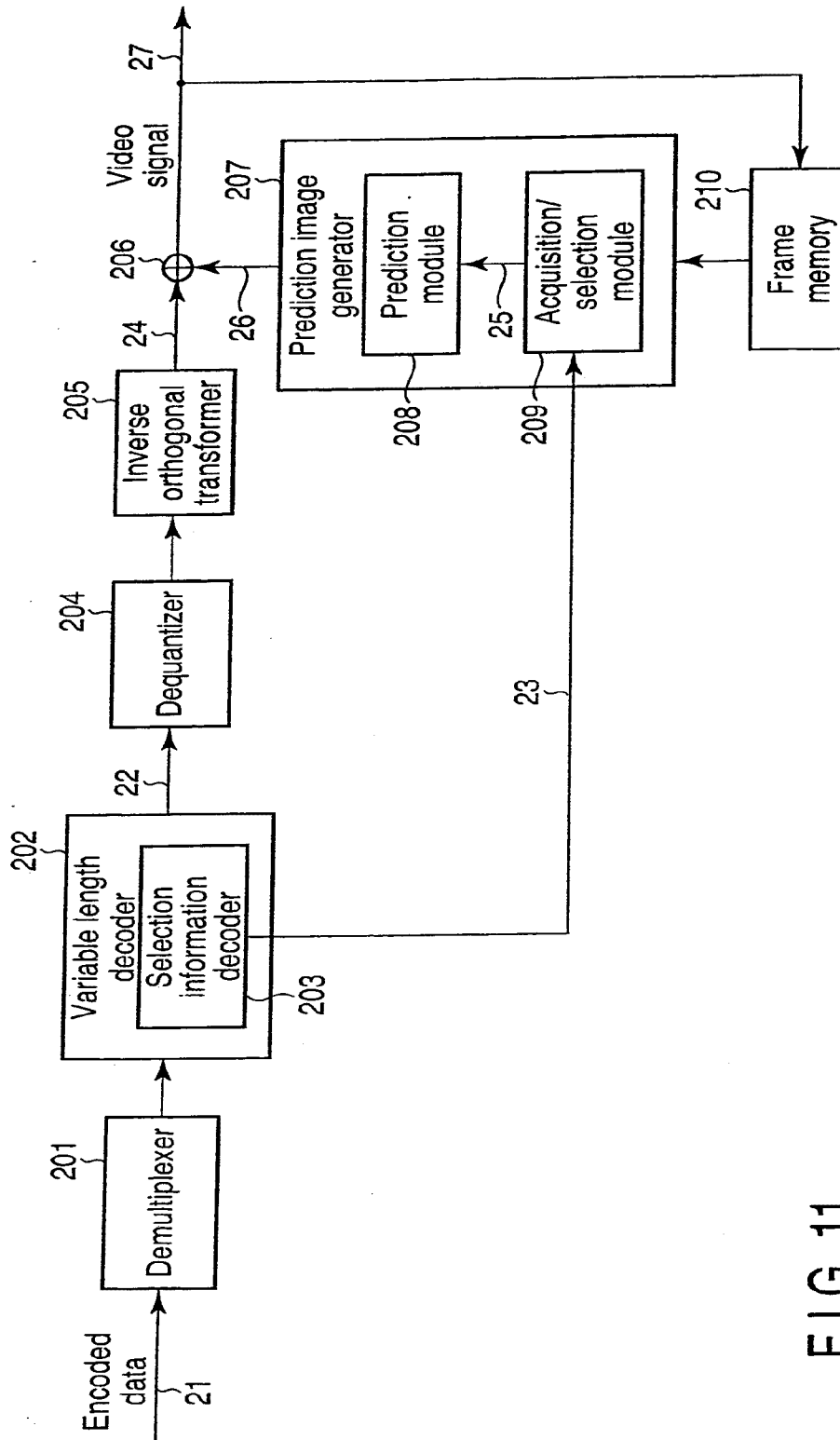

FIG. 11

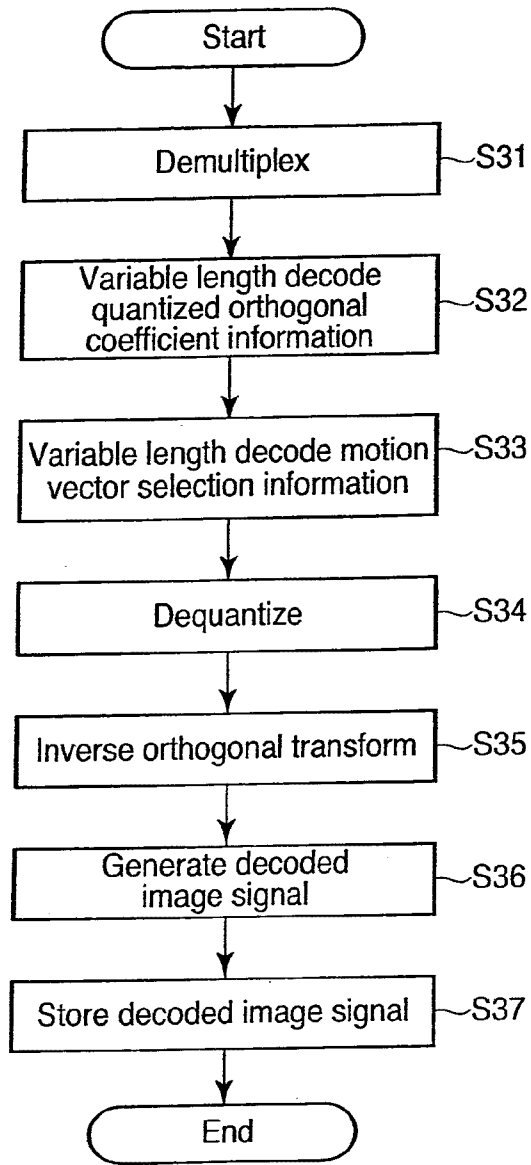

FIG. 12

