



INTERNATIONAL APPLICATION PUBLISHED UNDER THE PATENT COOPERATION TREATY (PCT)

<p>(51) International Patent Classification⁶ : E21B 10/40</p>	<p>A1</p>	<p>(11) International Publication Number: WO 98/32945 (43) International Publication Date: 30 July 1998 (30.07.98)</p>
<p>(21) International Application Number: PCT/US98/01608 (22) International Filing Date: 28 January 1998 (28.01.98) (30) Priority Data: 08/790,066 28 January 1997 (28.01.97) US (71)(72) Applicant and Inventor: HOLTE, Ardis, L. [US/US]; - (**). (74) Agents: BROWN, Glenn, C. et al.; Marger, Johnson, McColom & Stolowitz, P.C., 1030 S.W. Morrison Street, Portland, OR 97205 (US).</p>		<p>(81) Designated States: AL, AM, AT, AU, AZ, BA, BB, BG, BR, BY, CA, CH, CN, CU, CZ, DE, DK, EE, ES, FI, GB, GE, HU, IL, IS, JP, KE, KG, KP, KR, KZ, LC, LK, LR, LS, LT, LU, LV, MD, MG, MK, MN, MW, MX, NO, NZ, PL, PT, RO, RU, SD, SE, SG, SI, SK, TJ, TM, TR, TT, UA, UG, US, UZ, VN, ARIPO patent (GH, GM, KE, LS, MW, SD, SZ, UG, ZW), Eurasian patent (AM, AZ, BY, KG, KZ, MD, RU, TJ, TM), European patent (AT, BE, CH, DE, DK, ES, FI, FR, GB, GR, IE, IT, LU, MC, NL, PT, SE), OAPI patent (BF, BJ, CF, CG, CI, CM, GA, GN, ML, MR, NE, SN, TD, TG).</p> <p>Published <i>With international search report. Before the expiration of the time limit for amending the claims and to be republished in the event of the receipt of amendments.</i></p>

(54) Title: REVERSE CIRCULATION DRILLING SYSTEM WITH BIT LOCKED UNDERREAMER ARMS

(57) Abstract

A reverse circulation, pneumatic drilling assembly (10) wherein the bit assembly (11) is operatively connected to a dual wall pipe assembly (12). A supply of compressed air is conducted through the annulus of the dual wall pipe assembly (12) to a downhole pneumatic hammer (17). Exhaust air from the downhole pneumatic hammer is directed to the bit assembly (11) for continuous removal of drilling debris through a central evacuation tube of the dual wall pipe assembly (12).

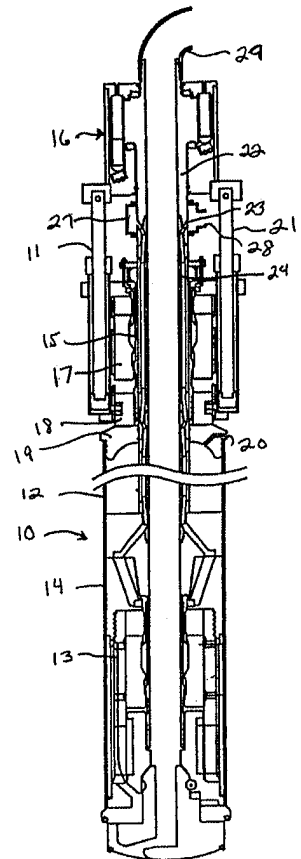

FOR THE PURPOSES OF INFORMATION ONLY

Codes used to identify States party to the PCT on the front pages of pamphlets publishing international applications under the PCT.

AL	Albania	ES	Spain	LS	Lesotho	SI	Slovenia
AM	Armenia	FI	Finland	LT	Lithuania	SK	Slovakia
AT	Austria	FR	France	LU	Luxembourg	SN	Senegal
AU	Australia	GA	Gabon	LV	Latvia	SZ	Swaziland
AZ	Azerbaijan	GB	United Kingdom	MC	Monaco	TD	Chad
BA	Bosnia and Herzegovina	GE	Georgia	MD	Republic of Moldova	TG	Togo
BB	Barbados	GH	Ghana	MG	Madagascar	TJ	Tajikistan
BE	Belgium	GN	Guinea	MK	The former Yugoslav Republic of Macedonia	TM	Turkmenistan
BF	Burkina Faso	GR	Greece			TR	Turkey
BG	Bulgaria	HU	Hungary	ML	Mali	TT	Trinidad and Tobago
BJ	Benin	IE	Ireland	MN	Mongolia	UA	Ukraine
BR	Brazil	IL	Israel	MR	Mauritania	UG	Uganda
BY	Belarus	IS	Iceland	MW	Malawi	US	United States of America
CA	Canada	IT	Italy	MX	Mexico	UZ	Uzbekistan
CF	Central African Republic	JP	Japan	NE	Niger	VN	Viet Nam
CG	Congo	KE	Kenya	NL	Netherlands	YU	Yugoslavia
CH	Switzerland	KG	Kyrgyzstan	NO	Norway	ZW	Zimbabwe
CI	Côte d'Ivoire	KP	Democratic People's Republic of Korea	NZ	New Zealand		
CM	Cameroon	KR	Republic of Korea	PL	Poland		
CN	China	KZ	Kazakhstan	PT	Portugal		
CU	Cuba	LC	Saint Lucia	RO	Romania		
CZ	Czech Republic	LI	Liechtenstein	RU	Russian Federation		
DE	Germany	LK	Sri Lanka	SD	Sudan		
DK	Denmark	LR	Liberia	SE	Sweden		
EE	Estonia			SG	Singapore		

REVERSE CIRCULATION DRILLING SYSTEM WITH
BIT LOCKED UNDERREAMER ARMS

BACKGROUND OF THE INVENTION

The present invention is related to earth drilling equipment, and particularly to down hole, pneumatic, percussive hammer drilling systems. As noted in my related co-pending application, serial no. 08/674,123, filed July 1, 1996, to which the present application is a continuation-in-part, underreamers are used for the formation of radially enlarged areas extending about a pilot bit for insertion of a casing.

Eccentrically mounted underreamers are known which include an arm which travels in an orbit for underreaming operation, and which are retractable toward the hole axis for tool removal purposes. However, eccentrically mounted underreamers can be diverted off-axis if the underreamer encounters rock fragments, buried metal objects, etc. Any diversion of a large drill bit is unacceptable in most drilling operations, and particularly where a series of closely spaced holes are being formed. The installation of casing in a drilled ground hole is also greatly hindered by any such diversion.

Other known underreaming equipment utilizes three bit

mounted plates which are outwardly displaceable, bit which incorporate a total working surface which is substantially less than the perimeter of the bore. Such undersized plates are subject to excessive wear and result in slow drilling operation. Underreaming can also be achieved by use of a crown or ring bit, but components of those bits must be left in the underreamed area when drilling is complete, which is costly and otherwise unacceptable in some drilling operations.

Each of these problems is addressed by my co-pending U.S. application serial no. 08/674,123, and by the additional related underreamer embodiments disclosed and claimed below.

In addition to the foregoing problems associated with known underreamers, quick and efficient removal of drilling debris from the hole and drilling bits remains a problem. In my U.S. Patent No. 5,511,628, which is hereby expressly incorporated by reference into this application, I disclosed a pneumatic down-hole drill with a central evacuation outlet. The apparatus of U.S. '628 permits continuous evacuation of large debris fragments through a central axial bore formed in the bit and through a central evacuation tube attached thereto. Compressed air is directed downwardly through peripheral channels, under the drill

bit, and into a central evacuation tube. The flow of compressed air through the central evacuation tube provides continuous and efficient removal of earthen fragments from the bore, including rapid removal of fragments which would be too large for removal through peripheral pathways along the casing.

However, a need remains for a reverse circulation pneumatic drill which provides for underreaming of the bore, continuous evacuation of drilling debris fragments from the drilling face in the bore, and for ready removal of the drill bit through the casing during or after completion of the drilling operation.

Summary of the Invention

The present invention is embodied in a reverse circulation system which addresses the shortcomings of the prior art.

It is therefore an object of the invention to provide an underreamer which includes a pilot bit on which are mounted underreamer arms which can be extended and retracted by relative rotation between the pilot bit and the underreamer arms. Each underreamer arm includes a strengthening boss. The strengthening boss includes axial bearing surfaces which engage corresponding axial surfaces of the pilot bit. The bearing surfaces of the arm

bosses and the bits include surfaces shaped to extend the arms as the pilot bit is rotated relative to the pilot bit. Surfaces are also provided for locking the arm in its extended underreaming position. As the bit is rotated in the opposite direction, the locking surfaces disengage and the arm can be retracted without vertical movement of the driver.

Brief Description of the Drawings

FIG. 1 is a partial cross-sectional view of a drilling assembly according to the present invention.

FIG. 2 is an expanded partial cross-sectional view of the assembly shown in FIG. 1, showing the power head assembly, compressed air inlet collar, and the upper terminus of the dual wall pipe assembly.

FIG. 3 is an expanded cross-sectional view of the assembly shown in FIG. 1, showing the casing driver in greater detail.

FIG. 4 is an expanded cross-sectional view of assembly shown in FIG. 1, showing the dual wall pipe assembly and the box and back head assembly connecting the lower terminus of the dual wall pipe assembly to the down-hole pneumatic hammer.

FIG. 5 is a cross-sectional view of the down-hole pneumatic

hammer assembly, including the bit assembly.

FIG. 5A is a perspective view of an alternative design for the hammer barrel of the down-hole pneumatic hammer assembly.

FIG. 6A is an exploded perspective view of a first embodiment of a bit assembly according to the present invention.

FIG. 6A is an exploded perspective view of a second embodiment of a bit assembly according to the present invention.

FIG. 7A is a perspective view of the pilot bit on the embodiment of FIG. 6A.

FIG. 7B is a bottom view of the pilot bit shown in FIG. 7A.

FIG. 8 is a perspective view of an underreamer arm used in the embodiment shown in FIG. 6A.

FIG. 9A is an end view of the underreamer arm shown in FIG. 8.

FIG. 9B is an outer side view of the underreamer arm shown in FIG. 8.

FIG. 10 is a bottom view of the bit driver of the embodiment shown in FIG. 6A, showing the axial surfaces which define the recesses which receive the underreamer arms, and the axial surfaces bear against the underreamer arms to rotate the arms about the pilot bit for extension and retraction.

FIG. 11 is side elevation view of the bit assembly shown in FIG. 6B.

FIG. 12 an enlarged exposed view of the bit assembly shown in FIG. 11.

Figures 13 and 14 are horizontal sectional views taken along line 3-3 of Figure 11 and showing the lower portion of the driver receiving the underreaming arms with the arms shown extended and retracted;

Figure 15 is a vertical sectional view taken along line 5-5 of Figure 13 showing a fragment of the driver bottom wall and an arm locking pad thereon;

Figure 16 is a vertical sectional view taken along line 6-6 of Figure 11; and

Figure 17 is a perspective view of an underreamer arm.

Detailed Description

Referring now to FIG. 1, a reverse circulation drilling system, shown generally at 10, includes a head assembly 11, a dual wall pipe assembly 12, and a down hole pneumatic hammer 13 within a bore casing 14. Turning to FIGS. 2 and 3, head assembly 11 includes a casing driver 15 for driving the bore casing 14

downwardly as the bit advances, and a power head assembly 16 of standard design for rotating the bore casing 14 it is driven downwardly. Casing driver 15 includes an annular hammer 17 which reciprocates vertically as compressed air is alternatively admitted to chambers above and below hammer 17. Hammer 17 impacts on anvil 18, which in turn impacts on casing cap 19. Casing cap 19 is sealed against the inner surface of bore casing 14 to permit pressurization, through port 20, of bore casing 14 between casing cap 19 and down hole hammer assembly 13. Pressurization of the casing provides a downward flow of air between the casing and the down hole hammer, preventing upward migration of debris between the down hole hammer and casing, which can hinder the removal of the hammer. Power head assembly 16 is connected to anvil 18 through linkage assembly 21 to impart rotation to the dual pipe assembly and the down hole hammer. Power head assembly 16 is of a design generally known in the field, other than its central member 22, which is threaded onto the upper end of dual wall pipe assembly 14, includes a central bore in communication with the dual wall pipe assembly to extend the debris discharge path through the power head to the elbow 29. The joint of central member 22 and the dual wall pipe 14 includes

a port 23 for admitting air to the annulus 24 between the inner wall 25 and the outer wall 26 of the dual wall pipe assembly. Collar 27 is mounted around the joint, and includes air inlet 28, through which compressed air is admitted into the dual wall pipe assembly for driving the down hole hammer as further described below. An elbow 29 is rotatably mounted and sealed to the upper end of central member 22. Elbow 29, central member 22 and the inner wall 25 of dual wall pipe assembly 14 together form a central drilling debris discharge tube for continuously discharging drilling debris from the down hole hammer as will also be described more fully below.

Turning also to FIG. 4, dual wall pipe assembly 12 is assembled from individual segments, each of which includes an inner pipe 31 and an outer pipe 33. Each segment includes a threaded male connector 33 and a threaded female connector 35 at opposite ends. Male connector 14 and female connector 15 each includes air ports 36 and 37 respectively which are in communication with outer annulus 24 of dual wall pipe assembly 11. At its upper end, dual wall pipe assembly is threaded in to central member 22 of power head 16. At its lower end, dual wall pipe assembly 11 is connected to the box 38, which in turn is

threaded into back head 40 of down-hole hammer 13. Ports 42 and 44 communicate with annulus 24 of the dual wall pipe assembly to route compressed air therefrom into the down hole hammer.

Turning now to FIG. 5, down-hole hammer 13 includes box 38 threaded onto back head 40. A sleeve 41 and a hammer barrel 42 are threaded into back head 40. A centrally located discharge tube 43 is pressed into sleeve 41. A wear sleeve 44 is fitted around hammer barrel 40, and press fitted over ring 45 and onto shoulder 46 of back head 40. Sleeve 41 and barrel 42 define an annular upper air chamber 48. Central evacuation tube 43 and barrel 42 define an annular lower air chamber 50. The lower end of barrel 42 abuts bit driver 52, and also includes a perimetrical lip 54 which engages wear sleeve 44 to center barrel 42 in the wear sleeve. Hammer 53 is slidably fitted into barrel 42 for reciprocation. Bit driver 52 is slidably fitted into barrel 42 below hammer 53, and over the lower end of central evacuation tube 43. Bit driver 52 is retained in barrel 42 by a plurality of keys 56, each of which is fitted into a keyway 58 and annular recess 60 of bit driver 52. (See also applicant's U.S. Patent No. 5,511,628, incorporated by reference above, for detail of an alternate barrel assembly incorporating a like key

and keyway assembly for mounting the bit driver in the hammer barrel.) The key-keyway assembly permits the bit assembly to advance ahead of the dual wall pipe assembly during drilling.

Bit assemblies for use with the present invention are shown in FIGS. 6-10. In one embodiment (FIG. 6A), a bit assembly consists of a bit driver 52, a pilot bit 82, and arms 88a-c. Bit driver 52 includes an upper shank 83 having a recessed chamfer 84, camming surfaces 85a and 85b, and a lower portion 86. Lower portion 86 includes three peripheral recesses 87a-c. Hardened drilling buttons, preferably made of a carbide material, are mounted on the peripheral and bottom surfaces of the pilot bit (FIG. 7). Arms 88a-c are nested atop pilot bit 82, and slide thereon in an prescribed arcuate path defined by as will be described. Each of the arms includes a raised boss 89 which is received into corresponding recess 90 of bit driver 52 (FIG. 10). Raised boss 89 serves several functions. First, impact forces from the hammer are transmitted downwardly to the pilot bit 52 through bit driver 52, boss 89, and arm 88. Second, boss 89 is received and retained in recess 90, where it rotates through a limited arc to extend and retract arm 88. With arm 88 in its retracted position, surface 91 is adjacent camming surface 85a.

in this configuration, the overall diameter of the bit assembly is less than the inner diameter of the bore casing, permitting the bit assembly to be withdrawn from the bore. As arm 88 is rotated clockwise about pilot bit 82 by clockwise rotation of bit driver 52, angled surfaces 85a engage surface 92 and urge arm 88 outwardly. The rotation and extension of arm 88 continues until surface 92a abuts surface 85b, and surface 92b abuts surface 85a, locking arm 88 in its extended position. To unlock and retract arm 88, bit driver 52 is rotated in the opposite direction. In its fully retracted position, the overall diameter of the underreamer assembly is less than the inside diameter of the casing, permitting withdrawal of the entire underreamer bit assembly through the casing if necessary. This feature represents a significant advance over known underreamers, which cannot be retracted and withdrawn through the casing if necessary.

In operation, compressed air is delivered into annular chamber 59 through port 37, radial ports 60, annulus 62 and axial ports 64. In FIG. 5, hammer 53 is shown during its downward stroke. Lip 66 is engaged with lip 68, sealing off chamber 48. Lip 72 is engaged with lip 74, sealing off chamber 50. Port 78

is closed. As piston 53 continues downwardly, port 76 is uncovered, exhausting chamber 48. At about the same time, lip 74 disengages from lip 72, admitting a fresh charge of compressed air into chamber 50 to raise piston 53 to its upper position after it has struck bit driver 52. As piston 53 rises, port 78 is uncovered, exhausting chamber 50. Lip 74 engages lip 72, sealing chamber 50. Port 76 is sealed by piston 53, and lip 66 disengages from lip 68, admitting a fresh charge of compressed air into chamber 48. The fresh charge of compressed air in chamber 48 drives piston 53 downwardly to begin another stroke. The compressed air exhausted into ports 76 and 78 is collected in port 80 (FIG. 5A), and discharged through the bit assembly into central evacuation tube 43, carrying with it drilling debris and earthen fragments dislodged by the bit. As an added precaution against drilling debris becoming lodged between arms 88a-c and the pilot bit, in the bit assembly embodiment shown in FIG. 6B, port 91 is provided through which compressed air can be discharged to clear debris.

The flow of compressed air through the bit assembly is essentially continuous, and provides a continuous evacuation of drilling debris from the drilling face of the bore. Moreover,

the essentially constant diameter of the evacuation tube and inner wall of the dual wall pipe assembly provides a constant air velocity, which further aids debris removal. The continuous removal of debris through the central evacuation tube promotes continuous drilling. It is seldom, if ever necessary to stop drilling and raise the bit to clear debris from the bore. Significant improvements in drilling rates can directly result. In addition, it is possible to obtain a relatively accurate "core" sample from the bore which can provide useful information in both exploratory and environmental applications.

An alternative bit assembly is shown in FIGS. 6B and FIGS. 11-17. The reference numeral 101 indicates generally the present drill bit assembly for attachment to the lower end of pneumatic down hole hammer. A driver at 102 includes a shank 103 of a diameter and splined for attachment to the percussive hammer. Integral with the shank is a driver head 104. About head 104 are circumferentially spaced channels 105 for upward passage of earthen particles or debris. An axially extending bore 106 of the driver receives a pressurized downward air flow for particle removal. Head 104 is cross bored off center at 107 to receive pin 108 engageable with a later described pilot bit of the drill

assembly.

A lowermost surface 110 of the driver head 104 defines a series of cylindrical sockets 111 uniformly spaced apart and from vertical axis at A of the driver (Fig. 13). Each socket has a companion elongate recess 113 formed in the lower portion of the driver to receive a limit stop pin of a later described underreamer arm. Additionally, lowermost surface 110 of head 104 is provided with multiple arm lock pads 114 in the form of downward projections which serve to lock each underreamer arm in an extended operative position. An internal wall of the driver includes segments 116 and 117 which define an open area which receives a cam block 118 and permits head movement thereabout. Irregular wall surfaces 116-117 alternately abut the cam block to limit driver rotation during arm positioning as later discussed.

A set of underreamer arms are indicated generally at 119 in Fig. 12 with the following description of one arm applicable to all of the arms at 120 which are generally of angular shape in plan view. With attention also to Fig. 17, an arm pivot post 121 seats in a socket 111 formed in the underside of head 14 of the driver. A limit stop post or pin 122 of the arm projects

upwardly into an elongate recess 113 in the underside of the driver head 104 with an end wall 113A of the recess limiting outward displacement of arm limit stop pin 122. Arm top and bottom walls are at 123-124 which both terminate outwardly in beveled arm outer edges 123A-124A, the lower beveled edge being provided with carbide inserts or buttons 125. An inner side wall 126 of an arm 120 moves about in relation to a later described cam block during arm deployment and retraction. A rearwardly beveled (relative arm rotation) arm end wall is at 127. Beveled arm edge 123A is engageable with the lower edge of a hole installed casing to contribute to inward arm movement during arm retraction at the end of a drilling operation. An arm shoulder at 128 cooperates with the lock pads 114 on the driver when deployed. The inner side wall 126 of each arm 120 travels along a wall surface of the cam block during arm positioning.

A pilot bit is generally indicated at 130 and includes a main body 131 having an uppermost surface 132 on which is centrally located cam block 118 with walls 136. Integral with cam block 118 is a pedestal 137 having an annular groove 138 thereabout to receive head carried pin 8 in a tangential manner. Groove 130 is oversize to permit upward displacement of driver 12

during arm positioning and subsequent locking of the arms. A compressed air central passageway is at 139 of the bit and is in registration with driver air passageway 106. Spaced about the lower perimeter 131 of drill bit 130 are channel 141 through which debris flows upwardly past the arms during a drilling operation. A bottom wall 142 of the drill bit defines radially disposed air channels 143 which are served with compressed air flows via internal passageways served by axial passageway 139. The lowermost surface 142 of the drill bit is suitably equipped with tungsten carbide buttons or other wear resistant members 144 commonly used in earth drilling equipment.

In drilling and underreaming operation pilot bit 130 advances into the ground with the underreamer arms locked in a deployed position below and radially beyond the advancing end of the casing at C. Casing movement is facilitated by the relatively large underreamed area, and if required, by the casing driver 15. In one embodiment, if the drill bit assembly advances more than a predetermined distance ahead of the casing, linkage 21 operates a valve to provide compressed air to the pneumatic hammer 17 and associated porting casing driver 15.

At completion of the operation, the driver is partially

rotated in the direction opposite to drilling rotation to shift the arm pivot pins and specifically the arm inner ends along cam block walls 36 to retract each arm. Arm retraction is aided by the beveled arm outer edges 123A engaging the bottom edge of casing C during retraction at the end of a drilling operation to permit removal of the drill bit assembly through the casing.

In operation with arms 53a-c extended, exhaust air from the down-hole hammer flows from port 42 through driver 51, arms 54a-c, pilot bit 56, and into central evacuation tube 17 (FIG. 2), carrying with it drilling debris. Applicant's routing of exhaust air from the down-hole hammer through the driver and into the underreamer assembly to continuously clean drilling debris from the underreamer assembly represents a significant improvement in the drilling art.

The foregoing description of the invention is intended to be illustrative rather than exhaustive. Those skilled in the art will appreciate that numerous changes in detail are possible without departing from the scope of the following claims.

CLAIMS:

1. A drill bit assembly for use with a down hole pneumatic hammer, comprising:

a driver;

a pilot bit having a shank, a peripheral drilling surface, a lower surface, and a bore extending from the lower surface generally upwardly through the shank;

coupling means rotatably coupling the driver to the pilot bit;

underreamer arms rotatably mounted intermediate the driver and the pilot bit and including underreaming surfaces positionable outside the pilot bit perimeter;

cam surfaces engageable with corresponding surfaces on the underreamer arms for deployment of the underreaming arms into an extended position, for locking the underreaming arms into the extended position, and for retracting the underreamer arms from the extended position by rotational movement between said driver and said pilot bit; and

surfaces defining at least one air passageway between an outer surface of the driver and the bore in the pilot bit.

2. The drill bit assembly of claim 1 wherein the at least one passageway includes a passageway between each said arm and its corresponding cam surfaces.
3. The drill bit assembly of claim 2 wherein the passageway is in communication with a source of compressed fluid.
4. The drill bit assembly of claim 3 wherein the compressed fluid comprises compressed air.
5. The drill bit assembly of claim 4 wherein the compressed air comprises compressed air exhausted from a first pneumatic hammer operably connected to the drill bit assembly.
6. The drill bit assembly of claim 1 which further comprises surfaces defining at least one fluid passageway in communication with a source of compressed fluid and at least one said cam surface, the passageway including a valve operable to discharge compressed fluid through said at least one cam surface.
7. The drill bit assembly of claim 1 which further comprises:

a well casing in which is disposed the first pneumatic hammer;

a casing driver operatively connected to the well casing.

8. The drill bit assembly of claim 7 in which the casing driver includes a second pneumatic hammer, a source of compressed air operatively connected to the second pneumatic hammer.

9. The drill bit assembly of claim 8 which further comprises a valve operatively connected to the second pneumatic hammer and the source of compressed air.

10. The drill bit assembly of claim 9 wherein the valve admits compressed air to the second pneumatic hammer responsive to a predetermined vertical offset between the bit driver and a lower end of the well casing.

FIG 1

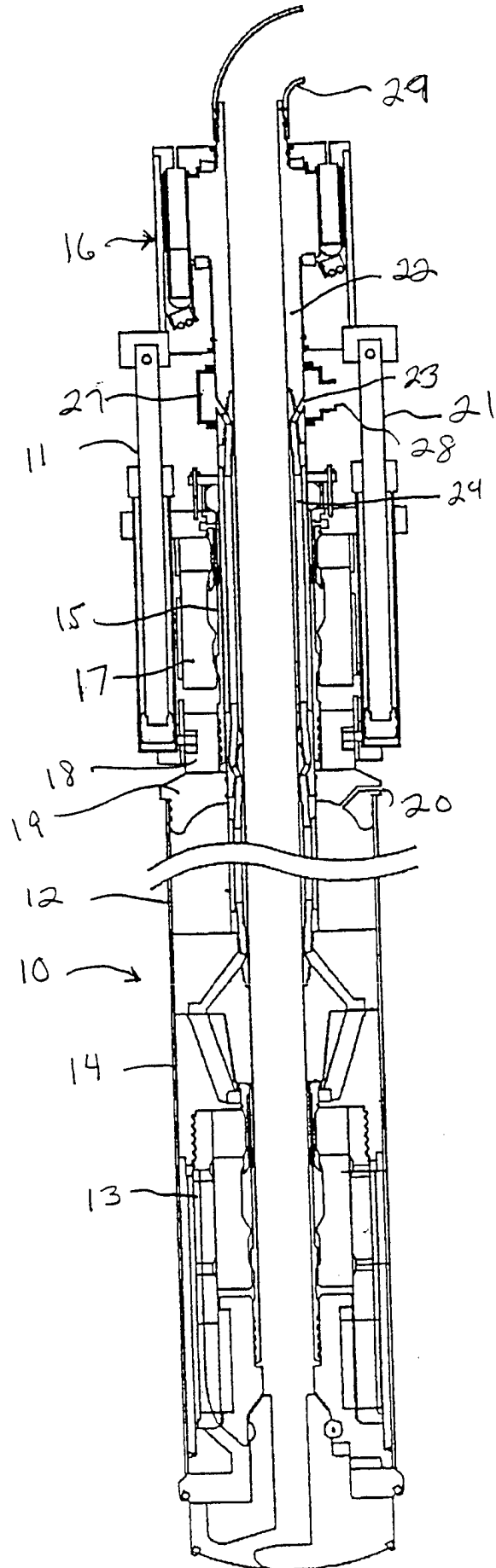

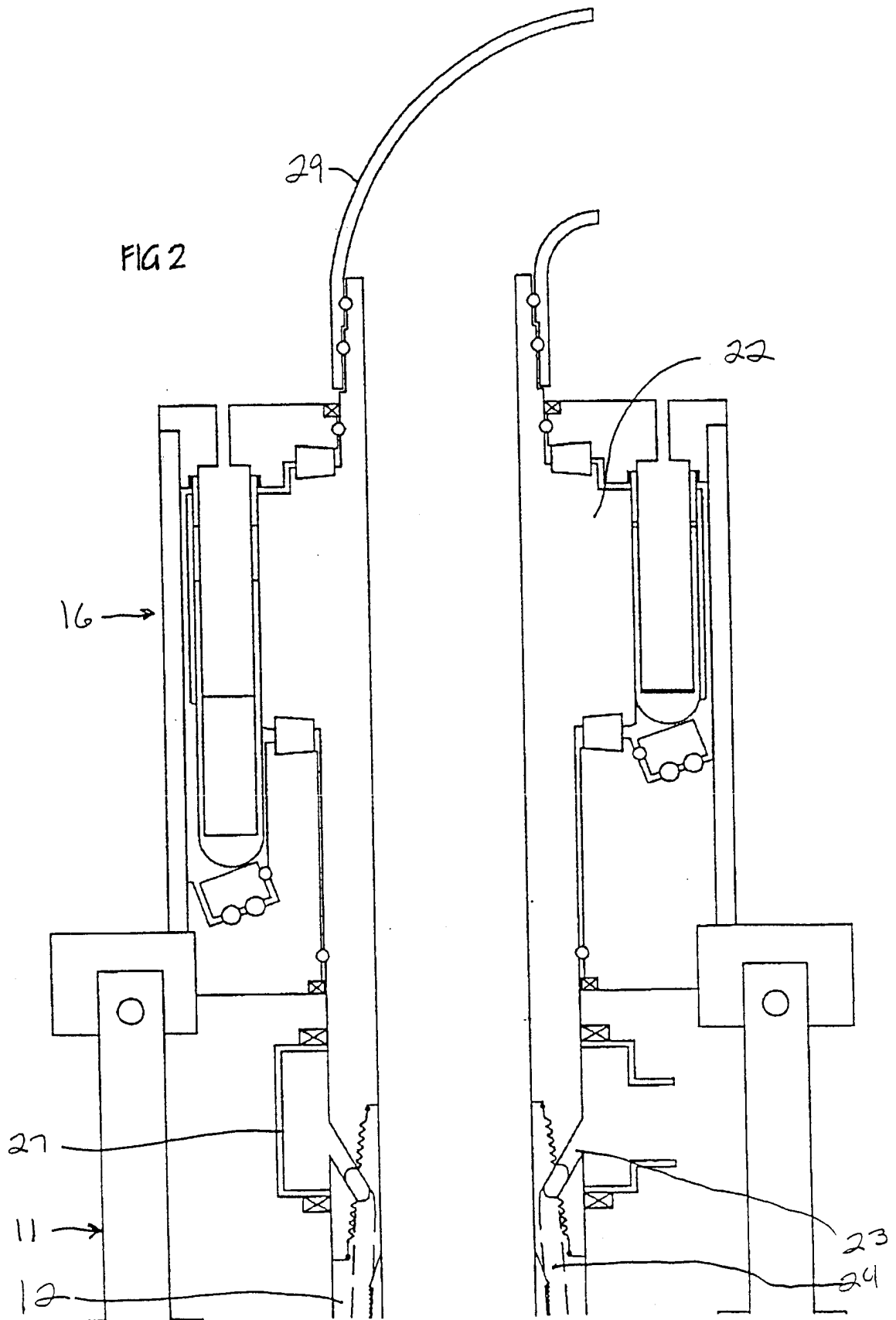
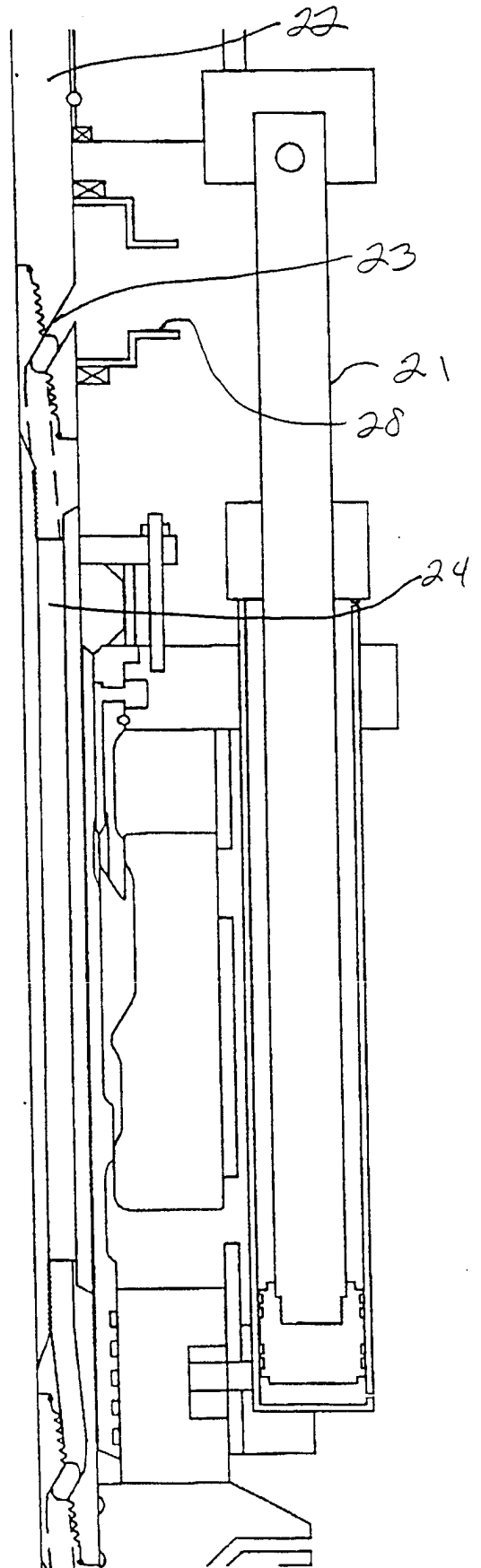
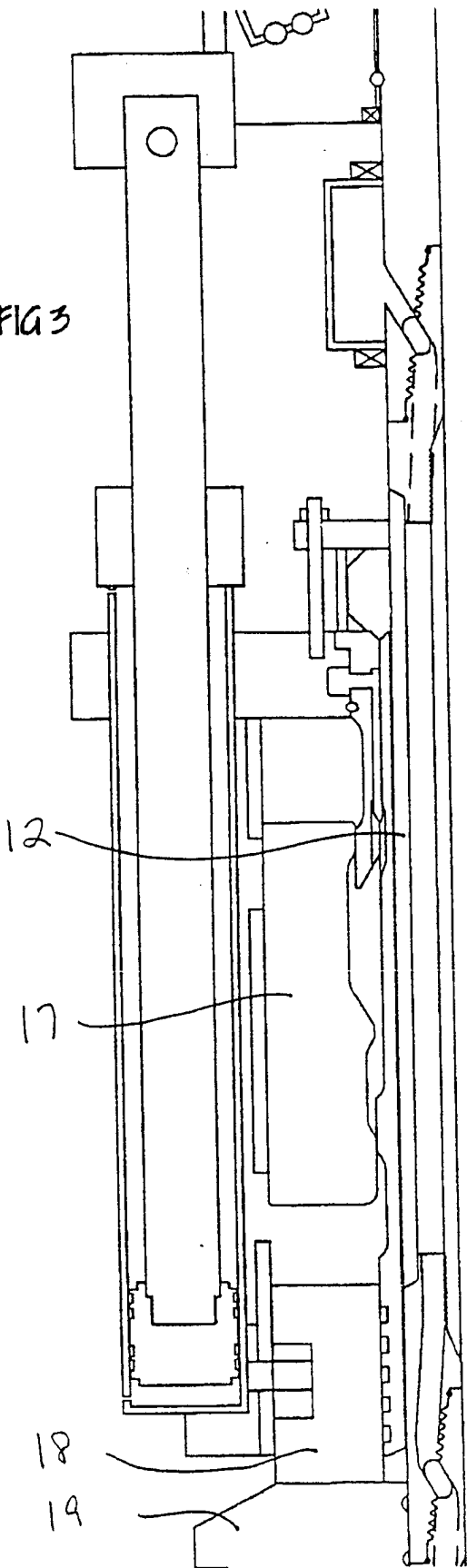
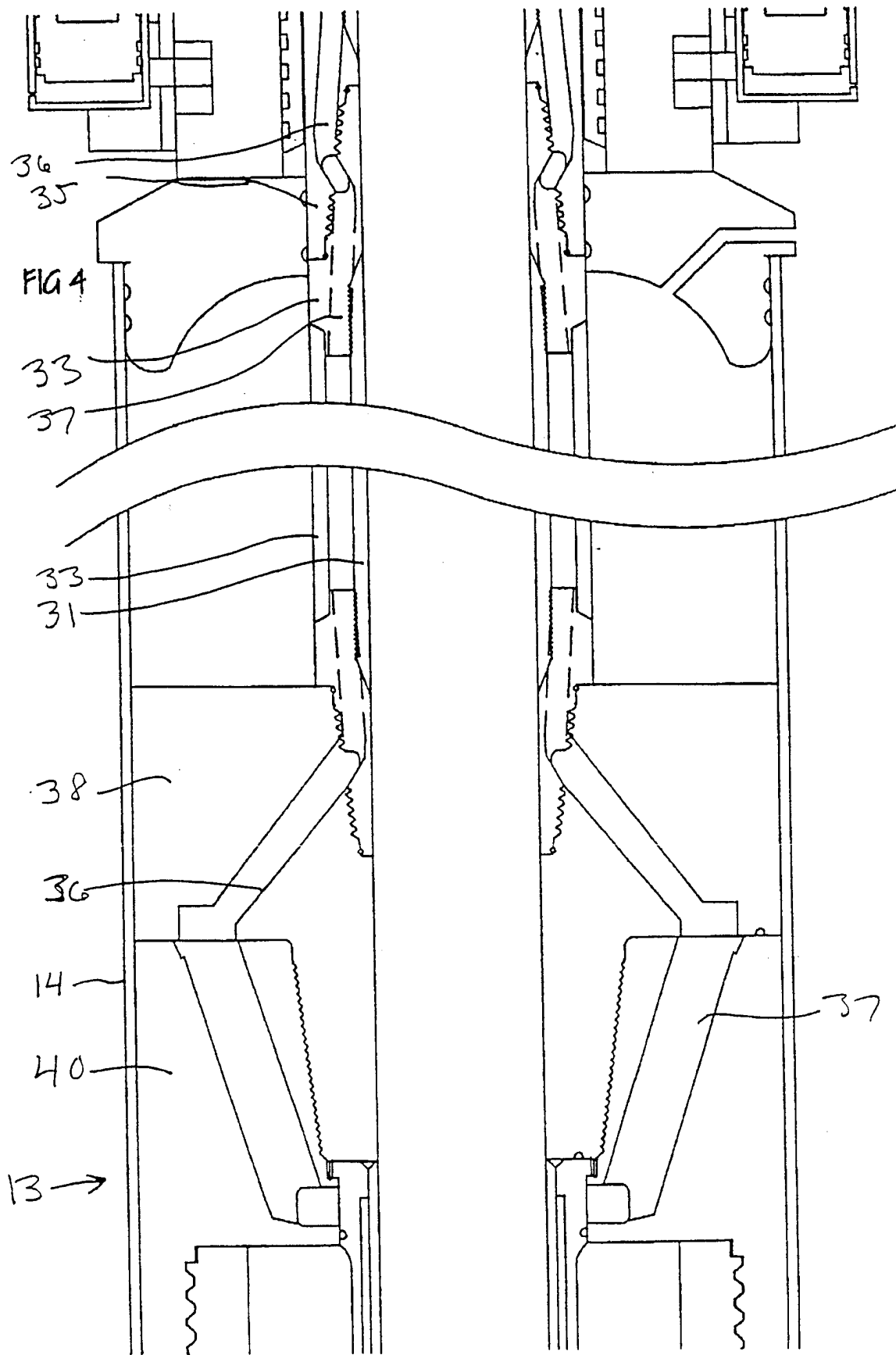
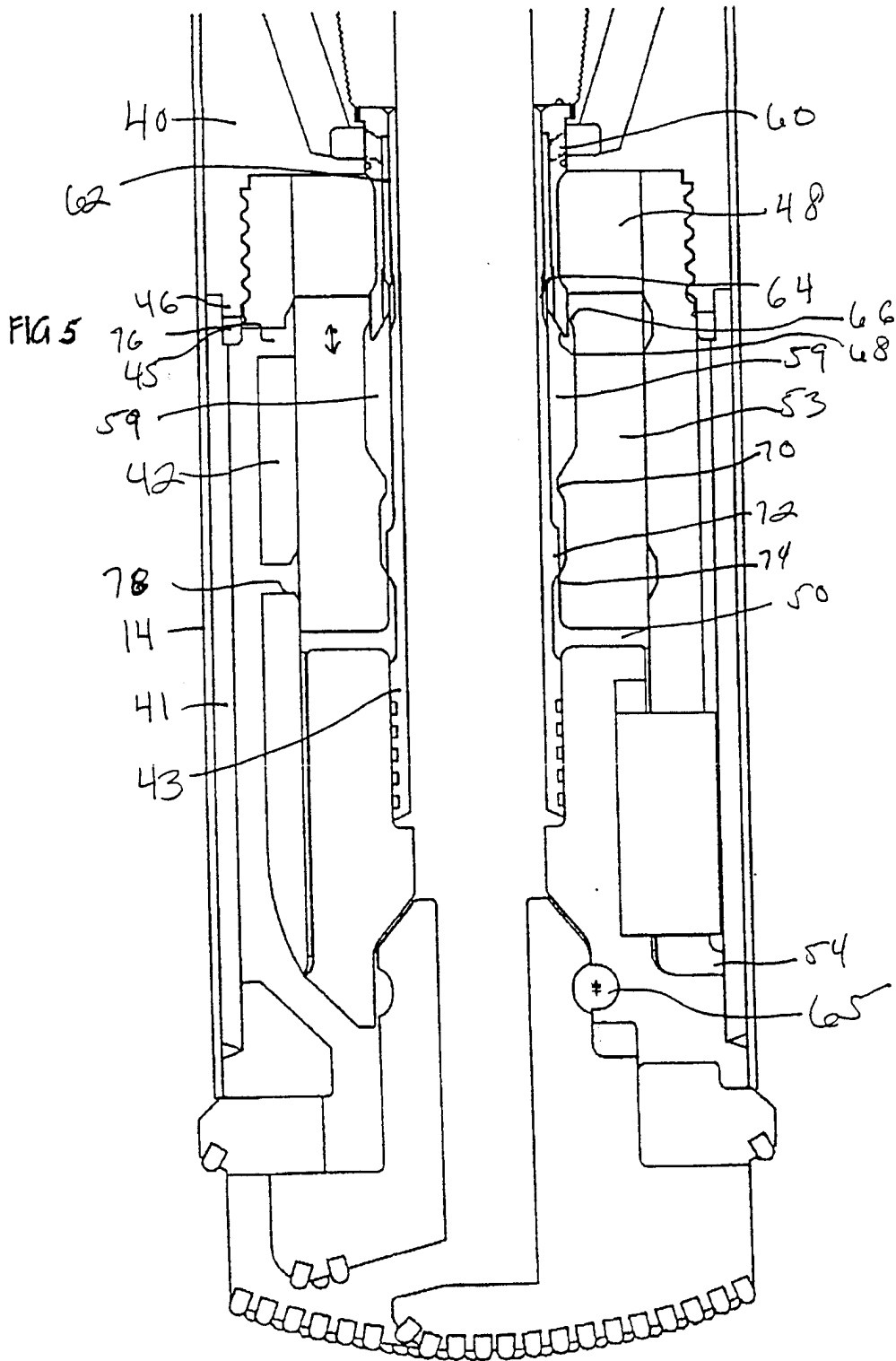
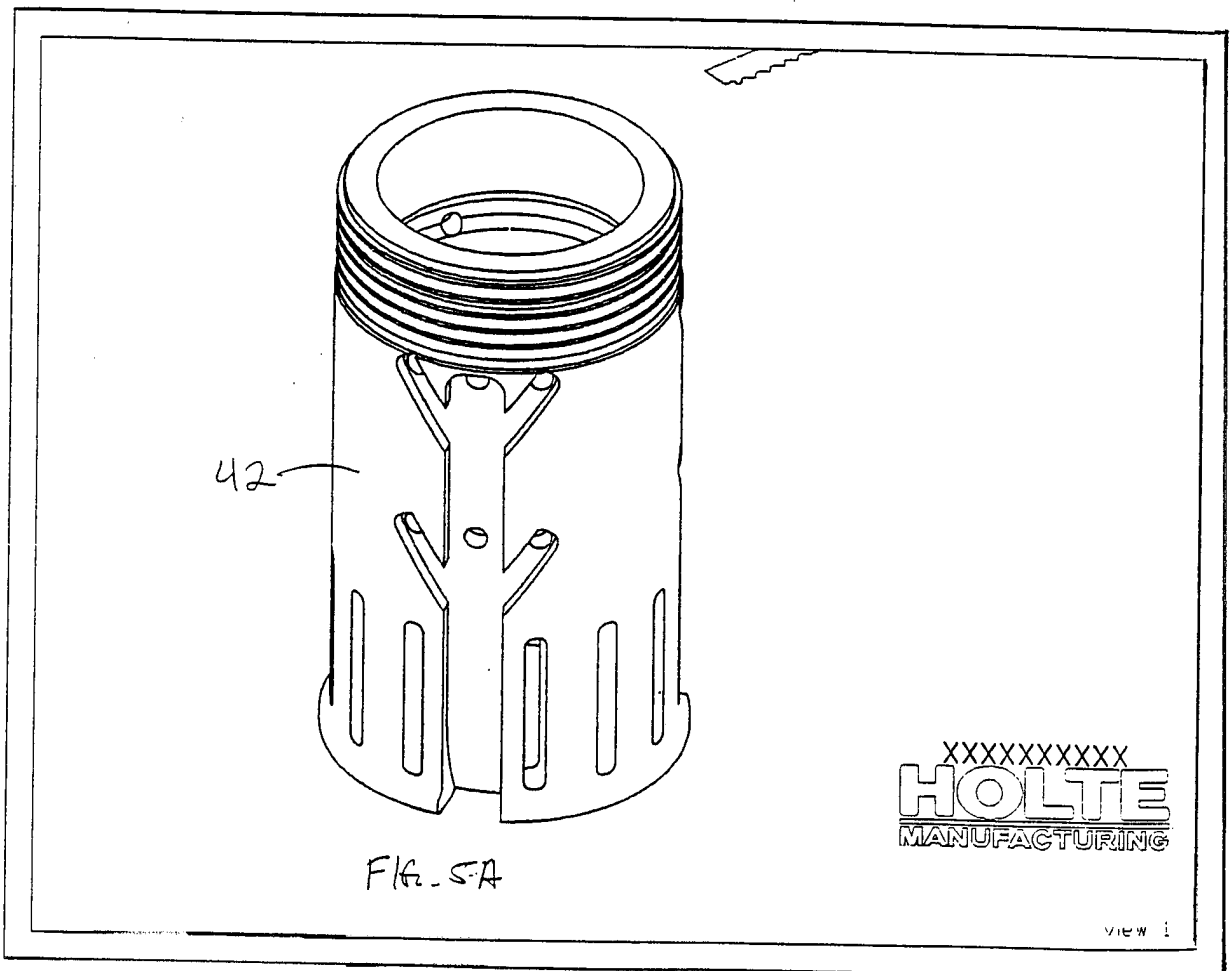

FIG 3









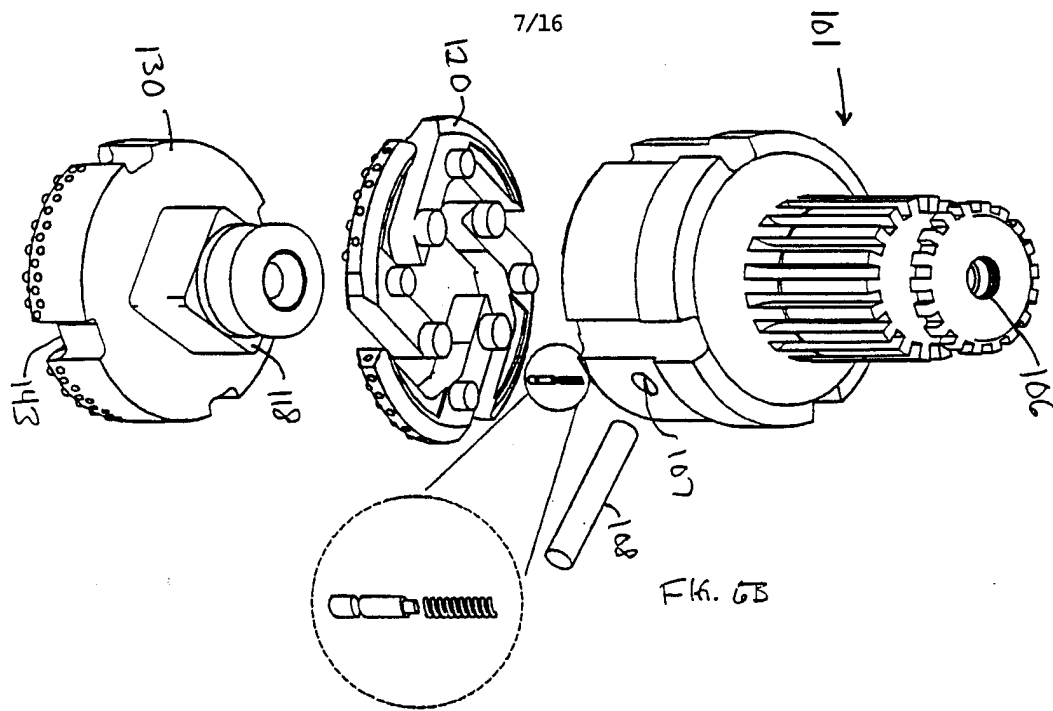

FIG. 6B

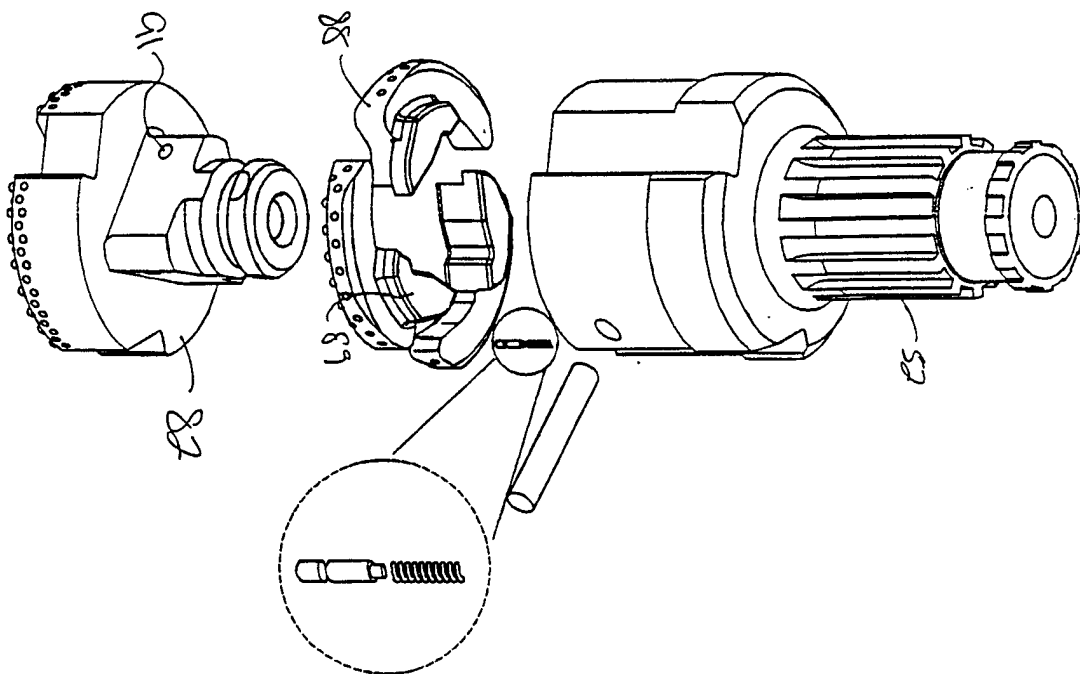
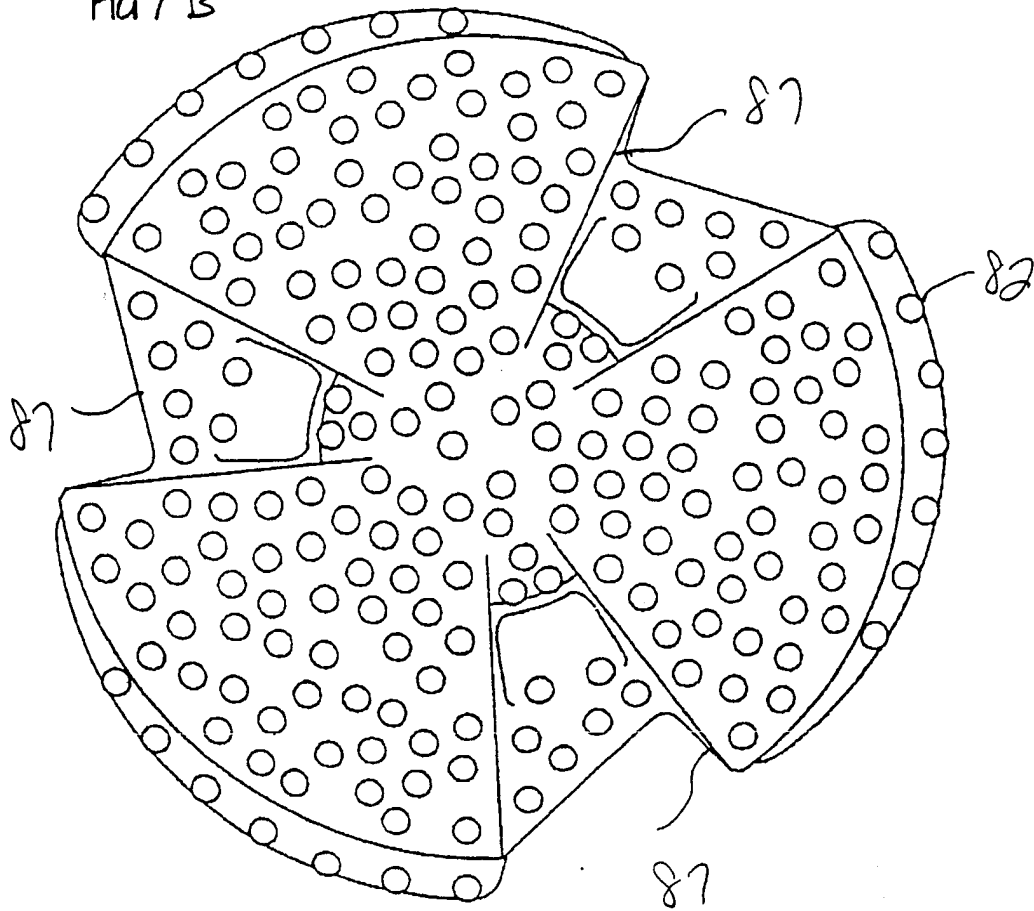

FIG. 6A

FIG 7 B



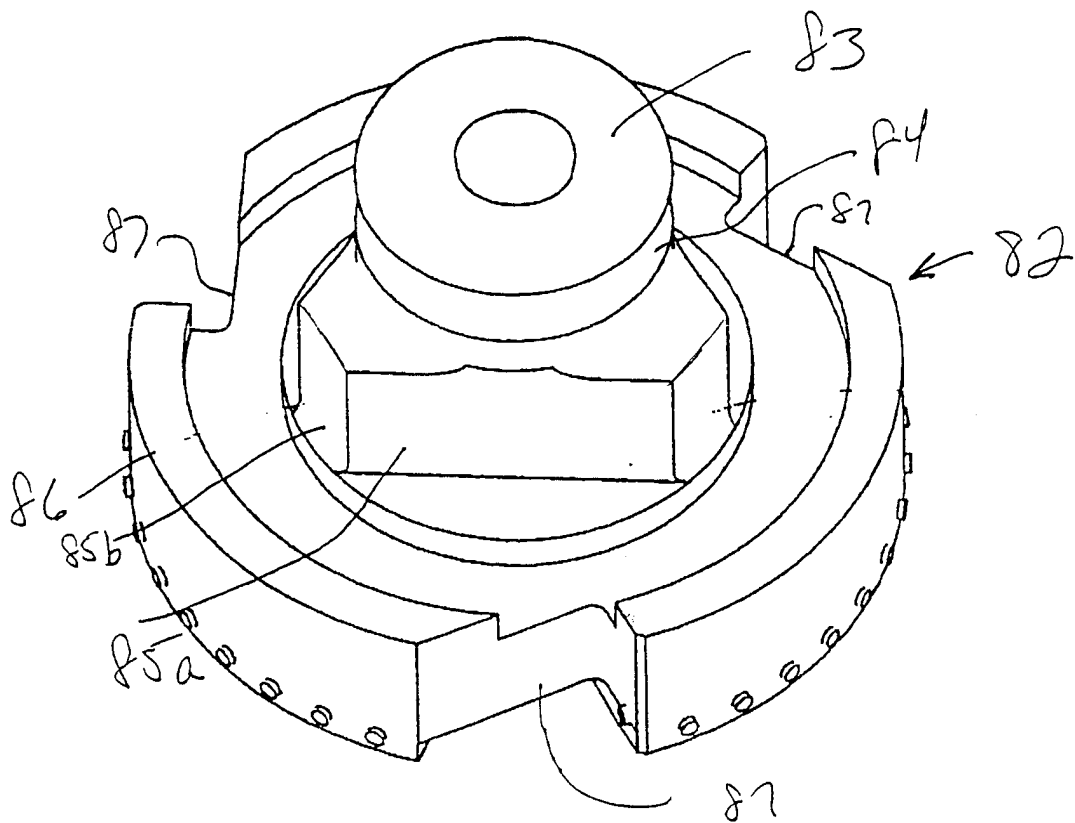

FIG. 7A

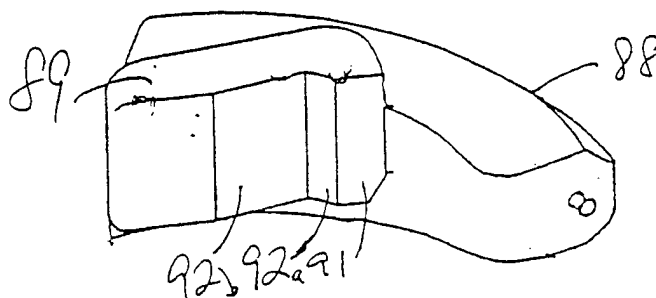

FIG. 8

FIG 9 A

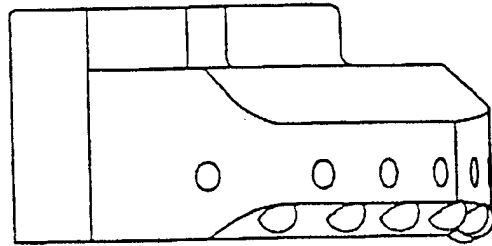

FIG. 9B

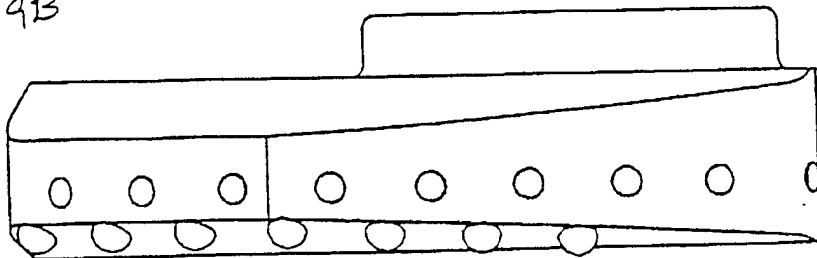

FIG. 10

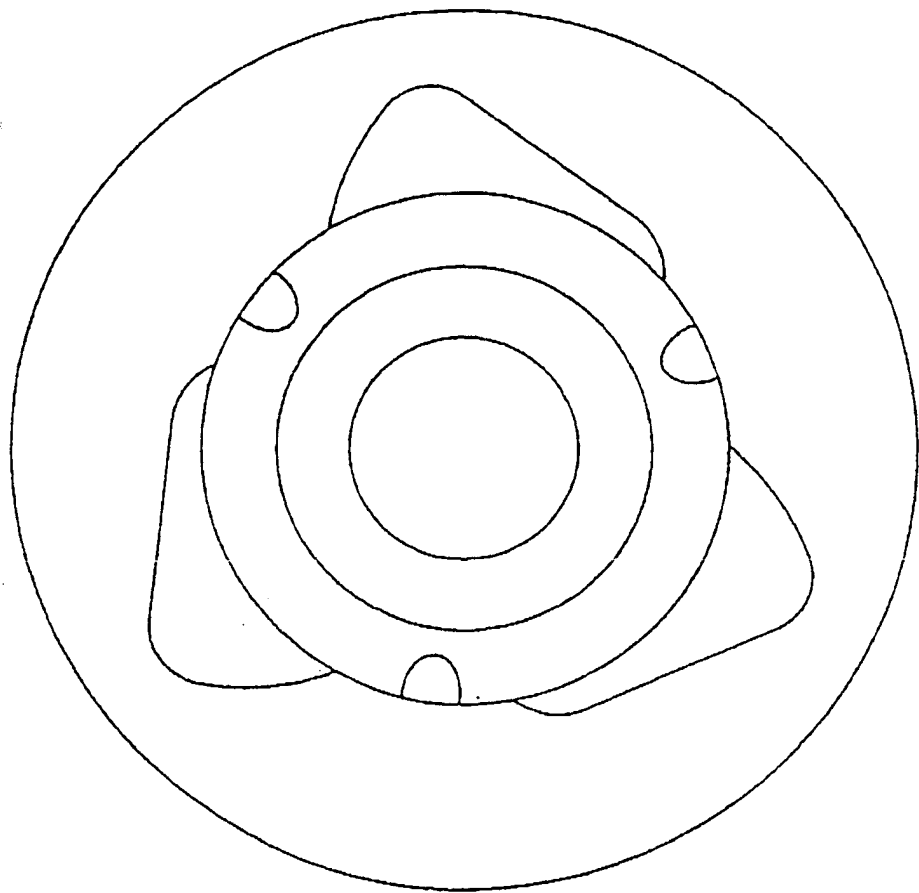

FIG. 11

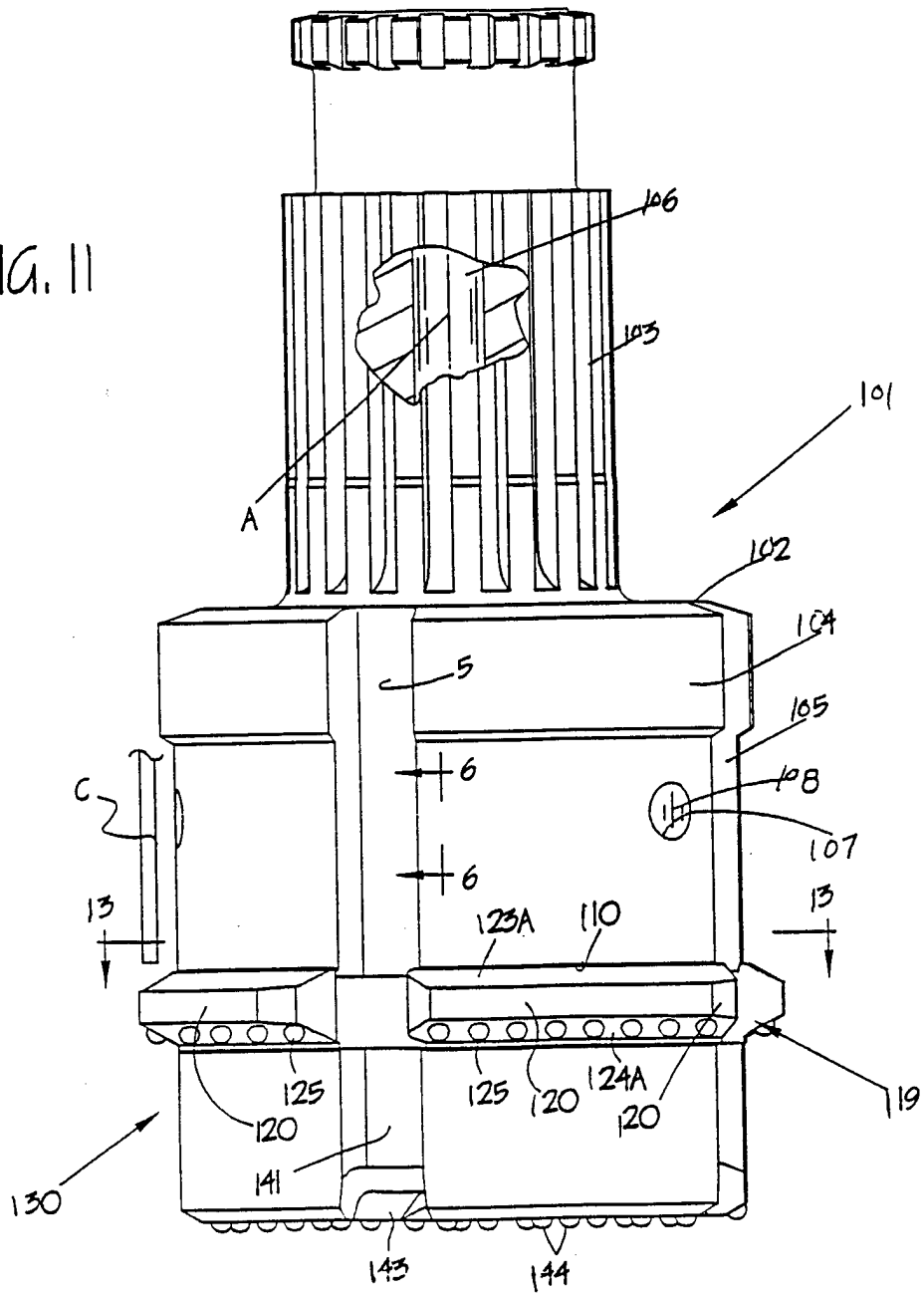
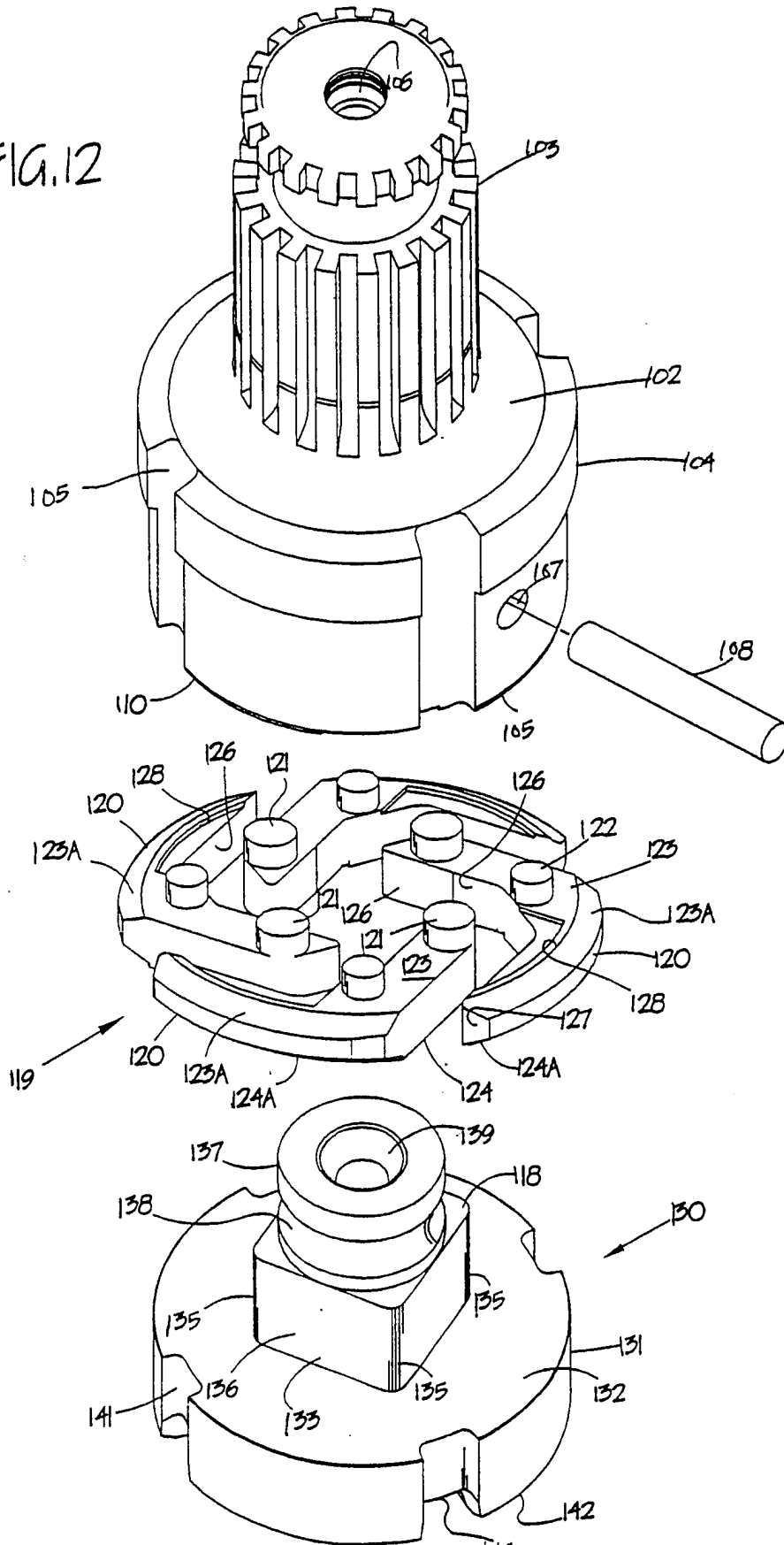

FIG. 12



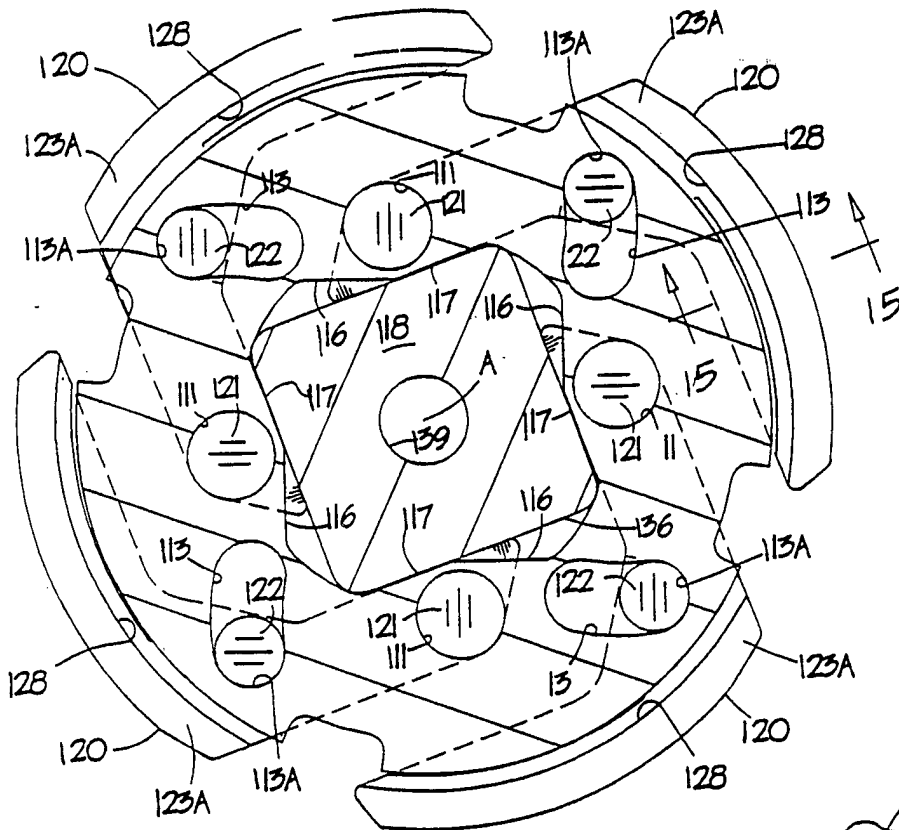

FIG. 13

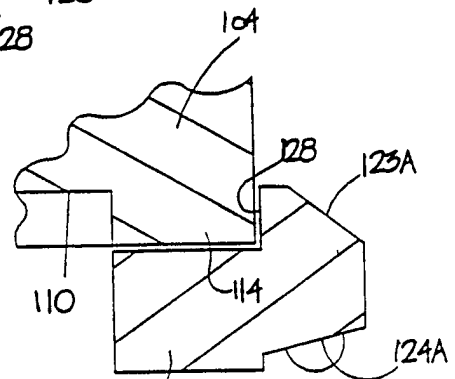

FIG. 15

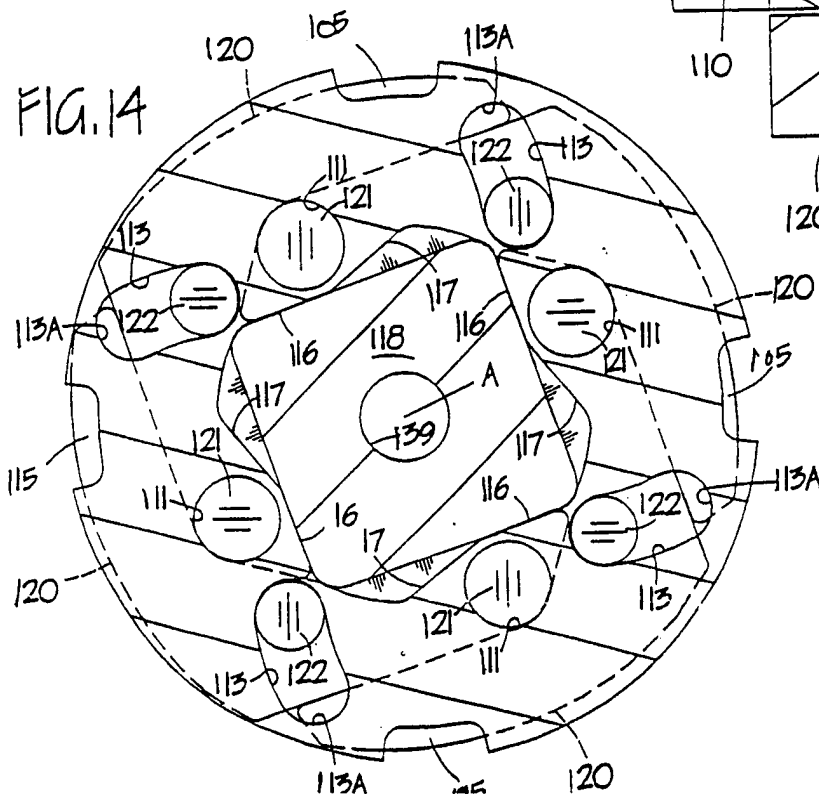

FIG. 14

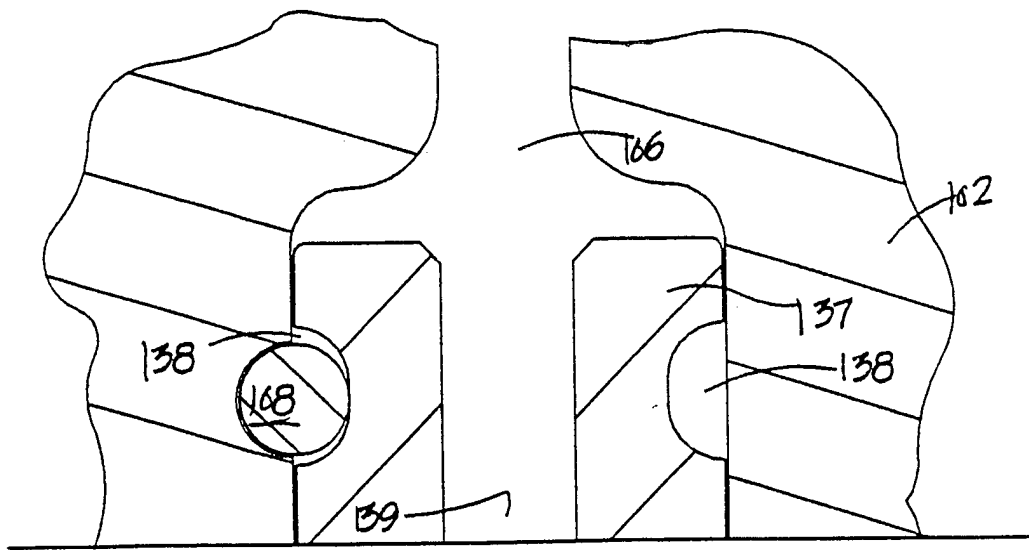

FIG. 16

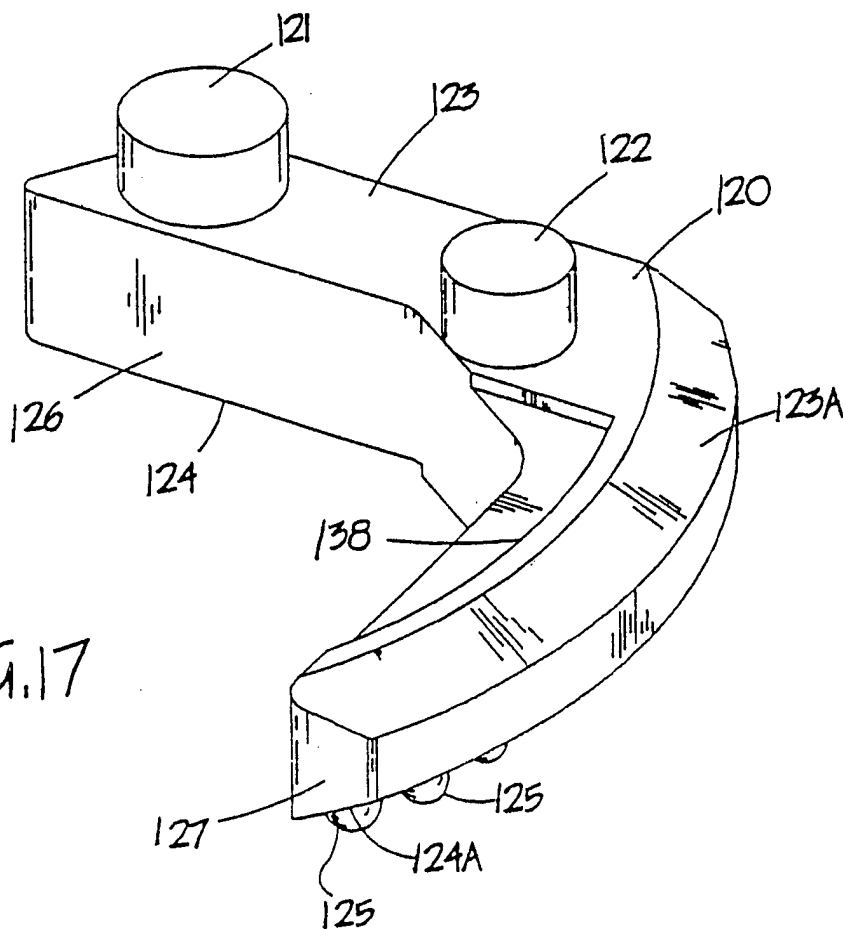

FIG. 17

INTERNATIONAL SEARCH REPORT

International application No.
PCT/US98/01608

A. CLASSIFICATION OF SUBJECT MATTER

IPC(6) :E21B 10/40
US CL :175/389

According to International Patent Classification (IPC) or to both national classification and IPC

B. FIELDS SEARCHED

Minimum documentation searched (classification system followed by classification symbols)

U.S. : 175/389,265,273,286,292,295

Documentation searched other than minimum documentation to the extent that such documents are included in the fields searched
none

Electronic data base consulted during the international search (name of data base and, where practicable, search terms used)
none

C. DOCUMENTS CONSIDERED TO BE RELEVANT

Category*	Citation of document, with indication, where appropriate, of the relevant passages	Relevant to claim No.
X	US 5,052,503 A (LOF) 01 October 1991 (01/10/91), see Figs. 1 and 2.	1-6

Further documents are listed in the continuation of Box C. See patent family annex.

* Special categories of cited documents:	*T* later document published after the international filing date or priority date and not in conflict with the application but cited to understand the principle or theory underlying the invention
A document defining the general state of the art which is not considered to be of particular relevance	*X* document of particular relevance; the claimed invention cannot be considered novel or cannot be considered to involve an inventive step when the document is taken alone
E earlier document published on or after the international filing date	*Y* document of particular relevance; the claimed invention cannot be considered to involve an inventive step when the document is combined with one or more other such documents, such combination being obvious to a person skilled in the art
L document which may throw doubts on priority claim(s) or which is cited to establish the publication date of another citation or other special reason (as specified)	*Z* document member of the same patent family
O document referring to an oral disclosure, use, exhibition or other means	
P document published prior to the international filing date but later than the priority date claimed	

Date of the actual completion of the international search

13 MAY 1998

Date of mailing of the international search report

09 JUN 1998

Name and mailing address of the ISA/US
Commissioner of Patents and Trademarks
Box PCT
Washington, D.C. 20231

Facsimile No. (703) 305-3230

Authorized officer

WILLIAM P. NEUDER

Telephone No. (703) 308-2168

Diane Goodwyn