

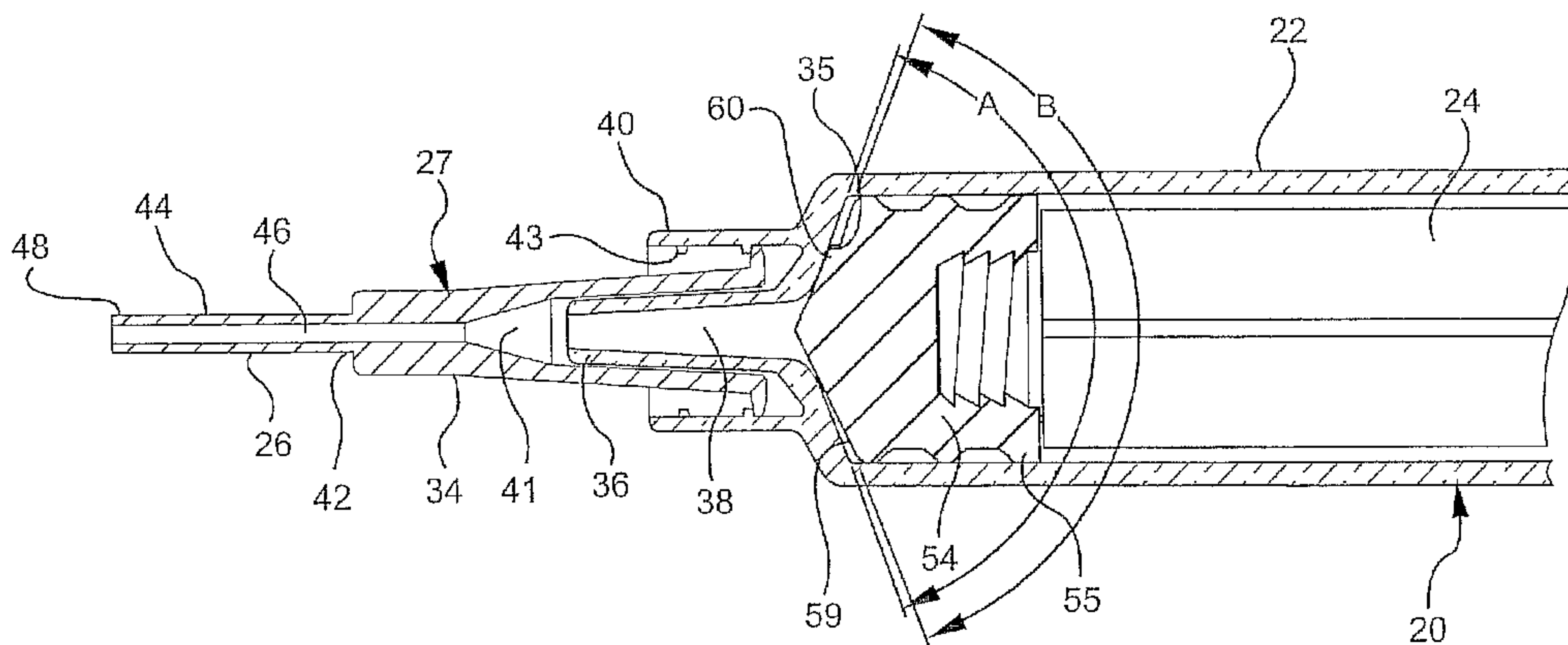

(86) Date de dépôt PCT/PCT Filing Date: 2004/11/23
 (87) Date publication PCT/PCT Publication Date: 2005/07/07
 (85) Entrée phase nationale/National Entry: 2006/06/06
 (86) N° demande PCT/PCT Application No.: US 2004/039215
 (87) N° publication PCT/PCT Publication No.: 2005/061030
 (30) Priorité/Priority: 2003/12/09 (US10/731,827)

(51) Cl.Int./Int.Cl. *A61M 5/315* (2006.01)
 (71) Demandeur/Applicant:
 BECTON, DICKINSON AND COMPANY, US
 (72) Inventeurs/Inventors:
 ALHEIDT, THOMAS A., US;
 TIMKO, JAMES JOHN, US
 (74) Agent: GOWLING LAFLEUR HENDERSON LLP

(54) Titre : SERINGUE DE RINCAGE A BUTEE ANTI-REFLUX
 (54) Title: FLUSH SYRINGE HAVING ANTI-REFLUX STOPPER



(57) **Abrégé/Abstract:**

A method of making a flush syringe assembly (20) comprises providing a plurality of syringe barrels (22) having a chamber (33) with a conically-shaped distal wall (35) and providing a plurality of stoppers (54) having a conically-shaped distal surface (59). The method further includes selecting a stopper from the plurality of stoppers and a barrel from the plurality of barrels so that the total included angle (A) of the distal wall of the selected barrel is greater than the total included angle (B) of the selected stopper distal surface, and inserting the selected stopper into the chamber of the selected barrel.

(12) INTERNATIONAL APPLICATION PUBLISHED UNDER THE PATENT COOPERATION TREATY (PCT)

(19) World Intellectual Property
Organization
International Bureau



(43) International Publication Date
7 July 2005 (07.07.2005)

PCT

(10) International Publication Number
WO 2005/061030 A1

- (51) International Patent Classification⁷: **A61M 5/315**
- (21) International Application Number:
PCT/US2004/039215
- (22) International Filing Date:
23 November 2004 (23.11.2004)
- (25) Filing Language: English
- (26) Publication Language: English
- (30) Priority Data:
10/731,827 9 December 2003 (09.12.2003) US
- (71) Applicant (for all designated States except US): **BECTON, DICKINSON AND COMPANY** [US/US]; 1 Becton Drive, Franklin Lakes, NJ 07417-1880 (US).
- (72) Inventors; and
(75) Inventors/Applicants (for US only): **ALHEIDT, Thomas, A.** [US/US]; 300 Holland Mountain Road, Stockholm, NJ 07460 (US). **TIMKO, James, John** [US/US]; 3 Sparrow Drive, Sparta, NJ 07871 (US).
- (74) Agents: **HIGHET, David, W.** et al.; Becton, Dickinson and Company, 1 Becton Drive, Franklin Lakes, NJ 07417-1880 (US).
- (81) Designated States (unless otherwise indicated, for every kind of national protection available): AE, AG, AL, AM, AT, AU, AZ, BA, BB, BG, BR, BW, BY, BZ, CA, CH, CN, CO, CR, CU, CZ, DE, DK, DM, DZ, EC, EE, EG, ES, FI, GB, GD, GE, GH, GM, HR, HU, ID, IL, IN, IS, JP, KE, KG, KP, KR, KZ, LC, LK, LR, LS, LT, LU, LV, MA, MD, MG, MK, MN, MW, MX, MZ, NA, NI, NO, NZ, OM, PG, PH, PL, PT, RO, RU, SC, SD, SE, SG, SK, SL, SY, TJ, TM, TN, TR, TT, TZ, UA, UG, US, UZ, VC, VN, YU, ZA, ZM, ZW.
- (84) Designated States (unless otherwise indicated, for every kind of regional protection available): ARIPO (BW, GH, GM, KE, LS, MW, MZ, NA, SD, SL, SZ, TZ, UG, ZM, ZW), Eurasian (AM, AZ, BY, KG, KZ, MD, RU, TJ, TM), European (AT, BE, BG, CH, CY, CZ, DE, DK, EE, ES, FI, FR, GB, GR, HU, IE, IS, IT, LU, MC, NL, PL, PT, RO, SE, SI, SK, TR), OAPI (BF, BJ, CF, CG, CI, CM, GA, GN, GQ, GW, ML, MR, NE, SN, TD, TG).
- Declaration under Rule 4.17:**
— of inventorship (Rule 4.17(iv)) for US only
- Published:**
— with international search report
- For two-letter codes and other abbreviations, refer to the "Guidance Notes on Codes and Abbreviations" appearing at the beginning of each regular issue of the PCT Gazette.

(54) Title: FLUSH SYRINGE HAVING ANTI-REFLUX STOPPER

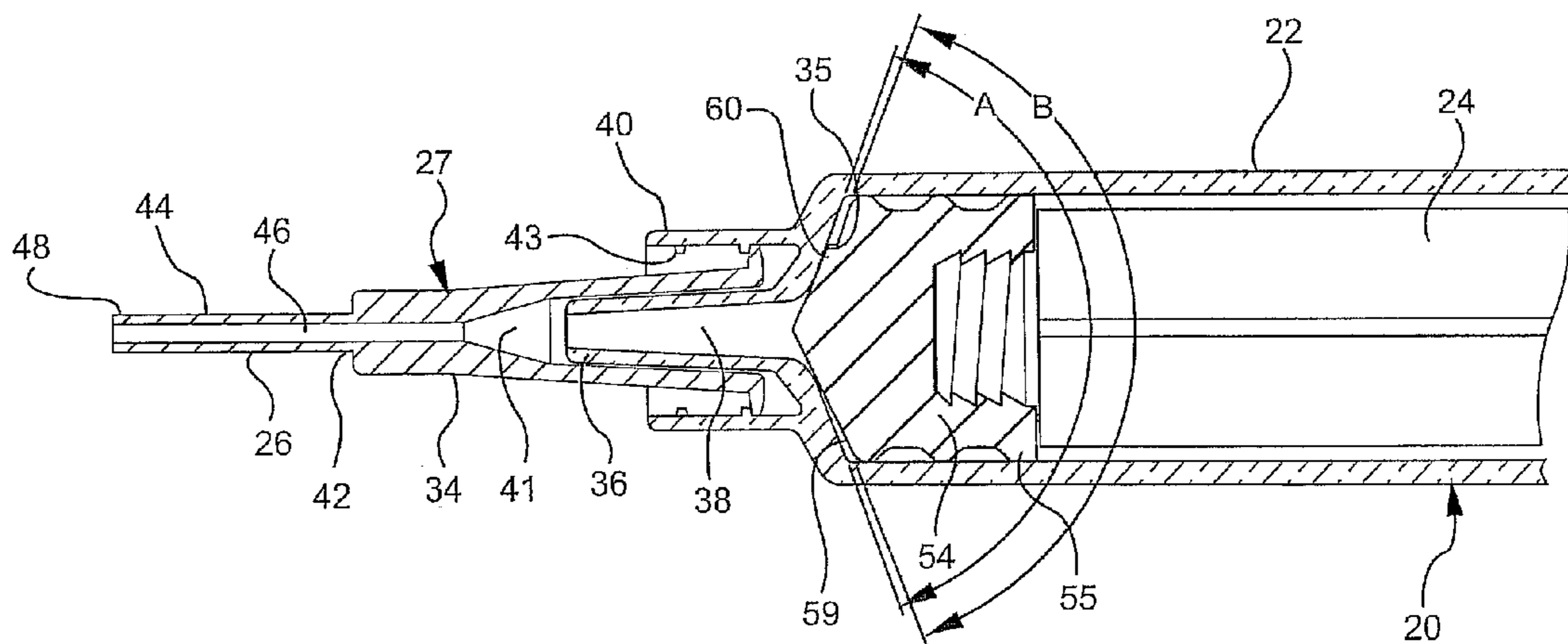

(57) Abstract: A method of making a flush syringe assembly (20) comprises providing a plurality of syringe barrels (22) having a chamber (33) with a conically-shaped distal wall (35) and providing a plurality of stoppers (54) having a conically-shaped distal surface (59). The method further includes selecting a stopper from the plurality of stoppers and a barrel from the plurality of barrels so that the total included angle (A) of the distal wall of the selected barrel is greater than the total included angle (B) of the selected stopper distal surface, and inserting the selected stopper into the chamber of the selected barrel.

WO 2005/061030 A1

FLUSH SYRINGE HAVING ANTI-REFLUX STOPPER

5 FIELD OF THE INVENTION

[0001] The present invention relates to syringe assemblies and particularly to syringe assemblies for use in I.V. flush procedures.

BACKGROUND

10 [0002] An I.V. catheter is a commonly used therapeutic device. Many patients, in accordance with their therapy, have an I.V. catheter connected to a vein ready for use in various procedures or in fluid communication with an I.V. system for infusing liquids and medication. Many I.V. sets have I.V. ports which are in fluid communication with a catheter and allow access for the purpose of injecting
15 medication into the patient, and for use in flushing techniques to maintain catheter integrity. Healthcare facilities have flushing protocols which depend on the amount of time the catheter will remain in the patient and the type of catheter being used. For example, a peripherally inserted central catheter (PICC) is a long flexible catheter, which is typically inserted into the central venous system (optimally with
20 the tip terminating in the superior vena cava) via the superficial veins of the antecubital fossa. PICC lines are designed for use when intermediate or long-term therapy is prescribed.

[0003] These catheter lines must be periodically flushed with saline flush solution and/or heparin lock flush solution depending on the protocol. Among other things,
25 flushing saline solution removes blood from the catheter and heparin helps prevent the formation of future blood clots. The most common I.V. ports are covered by pierceable septums or pre-slit septums and are known in the art and sometimes referred to as "PRN" from the Latin *pro re nata* meaning "as the need arises". The septum is preferably made of rubber or another elastomeric material which permits
30 insertion of a sharp needle cannula in order to infuse fluids into or to withdraw fluids from the catheter. Upon withdrawal of the needle cannula the septum seals itself. Ports having pre-slit septums are used with blunt cannula. Typically, the blunt

cannula is attached to a syringe and the syringe is moved to place a gentle pressure on the pre-slit septum which is forced open by the blunt cannula to establish fluid communication. Also, some I.V. sets have access valves which are responsive to the frusto-conically shaped tip of a syringe barrel for allowing fluid communication
5 between the interior of the syringe and the catheter without the use of a cannula.

[0004] Catheters are flushed using syringe assemblies filled with various fluids. In some cases, different fluids are injected sequentially in accordance with the protocol. For example, a saline solution followed by an anticoagulant such as heparin. The size of the syringe used to flush I.V. lines varies by various factors
10 including the size and length of the catheter. Typically syringes of 1ml, 3ml, 5ml and 10ml volume are used.

[0005] It is important in the flush procedure not to draw blood back into the catheter where it can clot and seal the catheter, commonly referred to as "reflux". In order to prevent blood reflux into the catheter the user is encouraged to maintain
15 a positive pressure in the line during the flush procedure. This may involve slowly withdrawing the syringe and cannula from the I.V. port while still applying pressure to the syringe plunger rod during the flush procedure. When using a syringe with an elastomeric stopper, the stopper is often compressed when it contacts the distal end of the syringe barrel at the completion of the flush procedure. When a user relieves
20 the pressure to the plunger after the flush procedure is completed, the stopper will expand back to its normal size drawing liquid from the catheter into the syringe barrel. This is undesirable, since it can cause blood to enter the catheter at the catheter distal end (reflux). Problems with reflux of blood into the catheter are on the rise because IV lines are now being flushed by a wide variety of health care
25 workers not just those dedicated to catheter maintenance. These other health care workers, as a result of having many other aspects of patient care to be responsible for and who spend much less time flushing IV lines, are not as efficient as those dedicated to catheter maintenance.

[0006] Therefore there is a need for simple, straight forward easy-to-manufacture
30 syringe assemblies which helps reduce or eliminate reflux of blood into the catheter during and after the flushing procedure has occurred even if flush protocols and

procedures are not precisely followed. For example, prematurely releasing the compressive force on the stopper, which may cause reflux of blood into the catheter.

SUMMARY OF THE INVENTION

5 [0007] The present invention is directed to a syringe assembly for use in flush applications. The syringe assembly reduces or eliminates reflux of blood into the catheter by providing a conically shaped stopper surface having a total included angle less than the angle of the conically shaped distal wall of the barrel so that the stopper seals the barrel first at its center near the passageway which discharges
10 flush solution. Further compression of the stopper will be independent of this seal so that reflux is reduced or eliminated.

[0008] An I.V. flush syringe assembly comprises a barrel including a cylindrical sidewall having an inside surface defining a chamber for retaining fluid. The barrel includes an open proximal end and a distal end having a distal wall with an elongate
15 tip extending distally therefrom. The tip includes a passageway therethrough in fluid communication with the chamber. The plunger having an elongate body portion includes a proximal end, a distal end and a stopper slidably positioned in fluid-tight engagement with the inside surface of the barrel for drawing fluid into and driving fluid out of the chamber by movement of the stopper relative to the barrel. The
20 elongate body portion of the plunger extends outwardly from the open proximal end of the barrel. Anti-reflux structure is provided for controlling stopper deflection when fluid has been delivered from the chamber and the stopper is in contact with the distal wall of the barrel. Anti-reflux structure includes the stopper having a conically shaped distal surface and the barrel having a conically shaped inside
25 surface at its distal wall. The total included angle of the inside surface of the barrel at the distal wall is greater than the total included angle of the distal surface of the stopper by at least six degrees.

[0009] In one embodiment the total included angle of the distal surface of the stopper is about 110 degrees and the total included angle of the conically shaped
30 inside surface of the distal wall of the barrel is about 120 degrees.

[00010] The syringe assembly may further include at least one projection on the distal surface of the stopper positioned mostly in the space between the distal

surface of the stopper and the conically shaped inside surface of the distal wall of the barrel when the distal surface of the stopper first contacts the conically shaped inside surface.

5 [00011] The syringe assembly may also include flush solution in the chamber and a tip cap releasably connected to the tip of the syringe barrel for sealing the passageway. The flush solution may be selected from the group consisting of saline flush solution and heparin lock solution.

10 [00012] The syringe assembly may further include a needle assembly including a cannula having a proximal end, a distal end, and a lumen therethrough. A hub having an open proximal end containing a cavity and a distal end attached to the proximal end of the cannula so that the lumen is in fluid communication with the cavity of the hub. The needle assembly is removably attached to the tip of the barrel through engagement of the tip to the cavity of the hub so that the lumen is in fluid communication with the chamber of the barrel.

15 [00013] Another embodiment of the I.V. flush syringe assembly of the present invention comprises a barrel including a cylindrical sidewall having an inside surface defining a chamber for retaining fluid. The barrel includes an open proximal end and a distal end having a distal wall with an elongate tip extending distally therefrom having a passageway therethrough in fluid communication with the chamber. A
20 plunger includes an elongate body portion having a proximal end, a distal end and a stopper slidably positioned in fluid-tight engagement with the inside surface of the barrel for drawing fluid into and driving fluid out of the chamber by movement of the stopper relative to the barrel. The elongate body of the plunger extends outwardly from the open proximal end of the barrel. A tip cap is releasably connected to the
25 elongate tip of the barrel for sealing the passageway. A quantity of flush solution is in the chamber between the stopper and the distal wall. Anti-reflux structure for controlling stopper deflection when fluid has been delivered from the chamber and the stopper is in contact with the distal wall is provided. The anti-reflux structure may include the stopper having a conically shaped distal surface and the inside
30 surface of the barrel at the distal wall being conically shaped wherein the total included angle of the inside surface of the barrel at the distal wall is greater than the total included angle of the distal surface of the stopper by at least six degrees and

preferably at least about ten degrees. At least one projection on the distal surface of the stopper is provided. The at least one projection is positioned and/or sized so that when the stopper contacts the inside surface of the barrel any deflection of the projection will not store enough energy to move the stopper proximally to the extent
5 the stopper is disengaged from the inside surface of the distal end of the barrel near the passageway.

[00014] A method of flushing a catheter of the present invention comprises the steps of providing a syringe assembly having a barrel including a cylindrical side wall having an inside surface defining a chamber for retaining fluid, an open proximal
10 end and a distal end including a distal wall with an elongate tip extending distally therefrom having a passageway therethrough in fluid communication with the chamber, a plunger including an elongate body portion having a proximal end, a distal end and a stopper slidably positioned in fluid-tight engagement with the inside surface of the barrel for drawing fluid into and driving fluid out of the chamber by
15 movement of the stopper relative to the barrel, the elongate body portion extending outwardly from the open proximal end of the barrel, a quantity of flush solution in said chamber, and anti-reflux means for minimizing stopper deflection when the flush solution has been delivered from the chamber and the stopper is in contact with and pressed against the distal wall. The method further includes providing a
20 catheter having a proximal end, a distal end and a passageway therethrough and a housing having a hollow interior in fluid communication with the passageway, the housing having an access valve capable of engaging the elongate tip of the barrel for allowing fluid communication with the hollow interior of the housing. The method further includes the steps of placing the distal end of the catheter in a blood
25 vessel; engaging the elongate tip of the barrel with the access valve so that the passageway in the tip is in fluid communication with the hollow interior of the housing; applying force to the plunger to move the plunger in a distal direction with respect to the barrel so that the flush solution in the chamber flows through the passageway into the hollow chamber of the housing and through the passageway of
30 the catheter; continuing to apply force to the plunger until the stopper contacts and presses against the distal wall of the barrel; and disengaging said syringe assembly from said access valve.

[00015] An alternative method may include the step of attaching a needle assembly to the elongate tip of the barrel. The needle assembly includes a cannula having a proximal end, a distal end and a lumen therethrough and a hub having an open proximal end containing a cavity and a distal end attached to the proximal end of the cannula so that the lumen is in fluid communication with the cavity. The attachment of the needle assembly to the barrel is through frictional engagement between the cavity in the hub and the elongate tip. This alternative method is used with a catheter having a proximal end, a distal end and a passageway therethrough and a housing having a hollow interior connected to the catheter and in fluid communication with the passageway of the catheter. The housing further includes a septum for allowing fluid communication with the hollow interior. Fluid communication is established by forcing the distal end of the cannula through the septum so that the lumen of the cannula is in fluid communication with the hollow interior of the housing. Also, the cannula may be permanently attached to the barrel tip with or without the use of a hub. At completion of the flush procedure the cannula is withdrawn from the septum.

[00016] A method of making a flush syringe assembly having anti-reflux features comprises providing a plurality of barrels having a cylindrical sidewall including an inside surface defining a chamber for retaining fluid, an open proximal end and a distal end including a distal wall with an elongate tip extending distally therefrom having a passageway therethrough in fluid communication with the chamber. The inside surface of the barrel at the distal wall is conically-shaped. The method further includes the step of providing a plurality of stoppers capable of being sealably positioned in fluid-tight engagement with the inside surface of said barrels for drawing fluid into and driving fluid out of the chamber by movement of the stopper relative to the barrel. The stoppers each have a conically-shaped distal surface. Another step involves selecting a stopper from the plurality of stoppers and selecting a barrel from the plurality of barrels wherein the total included angle of the inside surface of the selected barrel at the distal wall is greater than the total included angle of the selected stopper distal surface, and inserting the selected stopper in the chamber of the selected barrel so that the distal end of the selected stopper faces the distal wall of the selected barrel. The method may also include providing a

plunger having an elongate body portion including a proximal end and a distal end, and attaching the distal end of the plunger to the proximal end of the stopper. The method can further include providing a tip cap configured for releasable connection to the tip of the barrel for sealing the passageway and, connecting the tip cap to the tip of the selected barrel. A further step may include placing a quantity of flush solution in the chamber of the selected barrel.

[00017] A flush syringe may be made by the method comprising providing a plurality of barrels having a chamber with an inside surface wherein the inside surface of the barrel at the distal wall of the barrel is conically-shaped and providing a plurality of stoppers having a conically-shaped distal surface. The method further includes providing a tip cap configured for releasable connection to the tip of a barrel for sealing the passageway and connecting the tip cap to the tip of a barrel selected from the plurality of barrels. A quantity of flush solution is then placed in the chamber of the selected barrel. A stopper is selected from the plurality of stoppers so that the total included angle of the selected barrel at its distal wall is greater than the total included angle of the selected stopper at its distal surface. The selected stopper is inserted in the chamber in the selected barrel so that the flush solution is contained generally between the distal wall of the selected barrel and the distal end of the selected stopper. The filled syringe may then be sterilized and placed in a protective package or placed in a protective package and then sterilized.

BRIEF DESCRIPTION OF THE DRAWINGS

[00018] FIG. 1 is a perspective view of a syringe assembly according to one embodiment of the invention.

[0010] FIG. 2 is a partially cross-sectioned side elevational view of the syringe assembly of FIG. 1 with a needle assembly attached.

[0011] FIG. 3 is a cross-sectional view of the syringe assembly of FIG. 1 taken along line 3-3.

[0012] FIG. 4 is a partial perspective view of the stopper and distal end of the plunger of the syringe assembly of FIG. 1.

[0013] FIG. 5 is an enlarged partial cross-sectional side elevation view of the distal end of the syringe assembly of FIG. 2.

[0014] FIG. 6 is an enlarged partial cross-sectional side elevational view of the distal end of the syringe assembly shown at the completion of a flush procedure.

[0015] FIG. 7 is a side-elevational view illustrating the syringe assembly in use with a catheter injection site.

5 [0016] FIG. 8 is a perspective view of a syringe assembly according to another embodiment of the invention.

[0017] FIG. 9 is partially cross-sectioned perspective view of the syringe assembly of FIG. 8, taken along line 9-9.

10 [0018] FIG. 10 is a partially cross-sectioned exploded side-elevation view of the syringe assembly and a tip cap.

[0019] FIG. 11 is an enlarged partially cross-sectioned side-elevation view of a pre-filled syringe assembly.

[0020] FIG. 12 is the pre-filled syringe assembly of FIG. 11 in a sealed protective package.

15

DETAILED DESCRIPTION

[0021] FIG. 1 shows a syringe **20** according to the present invention generally comprising a barrel **22** and a plunger **24**. The barrel **22** has a generally cylindrical side wall **23** including an open proximal end **28** having finger grips **29**, a distal end **30** having a distal wall **31** and an inside surface **32** defining a chamber **33** for retaining fluid. The inside surface of the barrel at the distal wall is conically shaped as indicated as numeral **35**. The conically shaped inside surface of the distal wall of the barrel has a total included angle A as illustrated in FIG. 5. Distal end **30** further includes a tip **36** having a passageway **38** in fluid communication with the chamber.

20

25 The distal end of barrel **22** preferably, but not necessarily includes a locking luer type collar **40** concentrically surrounding tip **36**. The inside surface of the collar includes at least one thread **43**. A cannula **26** includes a proximal end **42**, a distal end **44** and a lumen **46** therethrough. The distal end may include a sharp tip or a blunt tip **48** as shown. The cannula may be connected directly to the tip of the

30 syringe barrel to establish fluid communication between the lumen and the chamber. Also, the cannula may be part of a needle assembly **27** including a hub **34** having an open proximal end **37** containing a cavity **41** and a distal end **39** attached to the

proximal end of the cannula so that the lumen of the cannula is in fluid communication with the cavity. The cavity of the hub can be removably frictionally engaged to the tip of the barrel as illustrated in FIGS. 2, 5 and 6.

[0022] Plunger **24** includes an elongate body portion **25**, a proximal end **50** having a flange **51**, and a distal end **52**. A stopper **54** is disposed on projection **53** at distal end **52** of the plunger, preferably via threading engagement. Stopper **54** includes at least one rib and preferably a plurality of ribs **56** on its outside diameter. The stopper is slidably positioned in fluid-tight engagement with the inside surface of the barrel for drawing fluid into and drawing fluid out of the chamber, through the passageway, by movement of the stopper relative to the barrel. Stopper **54** includes a proximal end **55** having a cavity **57** therein for engaging projection **53** on the distal end **52** of the plunger. Stopper **54** further includes a distal end **58** having a conically-shaped distal surface **59** thereon. Conically-shaped distal surface **59** has a total included angle B as illustrated in FIG. 5. As will be explained in more detail hereinafter, total included angle A of the inside surface of the barrel at the distal wall is greater than total included angle B of the conically shaped distal surface of the stopper. Angle A is at least six degrees, and preferably at least about ten degrees more than angle B. In this preferred embodiment, angle A is about 120 degrees and angle B is about 110 degrees.

[0023] Stopper **54** preferably includes at least one projection or lug **60** on conically shaped distal surface **59**. Projection **60** keeps the stoppers from nesting or sticking to each other during the assembly process. For example, the conically-shaped distal surface of one stopper may position itself in the cavity of another stopper while the stoppers are together before assembly.

[0024] The stopper may be made of any material suitable for providing sealing characteristics while under compression. For example, the stopper may be made of thermoplastic elastomers, natural rubber, synthetic rubber or thermoplastic materials and combinations thereof. The plunger in this embodiment is preferably made of material which is more rigid than the stopper such as polypropylene, polyethylene and the like.

[0025] In operation, syringe **20** is connected to a needle assembly and filled with flush solution using known methods. The flush solution may be any solution

intended for flushing. It is preferred that the flush solution be selected from the group consisting of saline flush solution and heparin lock flush solution. These solutions are known in the art and readily available. An example of a saline flush solution is 0.9% Sodium Chloride USP. An example of a heparin lock flush solution is 0.9% Sodium Chloride with 100 USP units of Heparin Sodium per ml or 10 USP units of Heparin Sodium per ml. The syringe with needle assembly attached is used to pierce the pierceable septum or a blunt cannula may be inserted into a pre-split septum of a vial containing flush solution and the flush solution is drawn into the syringe barrel by pulling plunger rod flange **51** in the proximal direction while holding barrel **22**, to draw fluid through the needle cannula into fluid chamber **33**.

[0026] Alternatively, the syringe may be filled with flush solution during the manufacturing of the syringe via a sterile filling method. Such pre-filled syringes may be supplied with a tip cap, such as tip cap **45** releasably connected to tip **36** sealing passageway **38**. It is preferred that the tip cap is formed of material selected from the group of thermoplastic materials and elastomeric materials such as natural and synthetic rubber and thermoplastic elastomers.

[0027] The syringe is now ready for use in flushing a catheter of an I.V. set. I.V. sets can be very complicated and may include multiple injection ports, a valve and/or other components. For the purpose of illustrating the present invention a simplified I.V. set **64** is illustrated in FIG. 7. I.V. set **64** comprises an I.V. site **65** which includes a housing **67** having a hollow interior **68** and a septum **69** at its proximal end. A catheter **70** having a conduit therethrough extends from the distal end of the housing. For this I.V. set septum **69** is pre-slit for use with blunt cannula. The I.V. site may be a valve having structure for accepting the syringe barrel tip and being activated by the insertion of the tip to establish fluid communication with the catheter, such as the valve taught in U.S. Patent No. 6,171,287.

[0028] Blunt tip **48** of cannula **26** may be inserted through pre-split septum **69** of I.V. set **64**. Alternatively, a sharp tip of a needle cannula may be used to pierce a septum that is not pre-split, or the tip of the barrel may be engaged with a valve in the IV site. This establishes fluid communication between the interior **68** of the I.V. set and the chamber of the syringe barrel. The syringe barrel **22** is

preferably held via finger grips **29**. Pressure is then applied to flange **51** of the plunger, for example by a thumb, in the distal direction. This moves the plunger **24** having the stopper **54** on its distal end forcing the liquid such as flush solution **71** in the chamber **34** out of the chamber, through cannula **26** and into interior **68** of the I.V. set and then through catheter **70**.

[0029] Referring to FIG. 6 the position of the plunger and stopper at the completion of the flush procedure is shown. At the completion of the flush procedure conically-shaped distal surface **59** of the stopper contacts conically-shaped inside surface **35** of the distal end wall of the barrel near passageway **30** sealing the passageway so that further deflection of the stopper will have little or no effect on liquid in the passageway and the catheter. Accordingly, stopper deflection caused by additional unnecessary force applied to the plunger, at this time, which could cause reflux of blood into the catheter using prior art stoppers, is minimized or eliminated with the stopper of the present invention. The stopper may flex, however, this flexure will occur generally outside of the sealed area surrounding the entrance to the passageway. Further, projection **60** is shaped so that upon further deflection of the stopper through forces applied to the plunger, the projection will not be able to force the stopper to move proximally. That is, the projection cannot create enough force to move the stopper proximally to create reflux. It is preferred that the projection on the distal surface of the stopper be positioned mostly in space **61** between the conically shaped distal surface of the stopper and the conically shaped inside surface of the distal wall of the barrel as illustrated in FIG. 6. The projection should be sized and positioned so that it cannot absorb enough energy during deflection to move the stopper proximally and break the seal between the stopper and the barrel at the passageway. The projection can be angularly shaped having a distal surface at the same angle as inside surface **35** of the barrel as illustrated in FIG. 6.

[0030] FIGS. 8 and 9 illustrate an alternative embodiment of the syringe assembly of the present invention. In this embodiment syringe assembly **120** comprises a barrel **122** including a cylindrical sidewall **123** having an inside surface **132** defining a chamber **133** for retaining fluid. Distal end **130** of the barrel includes a distal wall **131** having an elongate tip **136** extending distally therefrom.

The tip includes passageway **138** which is in fluid communication with the chamber. The distal wall includes conically-shaped inside surface **135**.

[0031] A plunger **124** includes an elongate body portion **125** having a distal end **152** and a resilient stopper **154** slidably positioned in fluid-tight engagement with the inside surface of the barrel. The stopper includes at least one rib **156** and a conically-shaped distal surface **159** at distal end **158**. The total included angle of the conically-shaped inside surface A of distal wall **131** is greater than conically-shaped distal surface B on the stopper by at least eight degrees. In this embodiment the difference between angle A and angle B is about 20 degrees.

[0032] The distal surface of the stopper includes a plurality of projections or lugs **160** which are sized and positioned not to interfere with the sealing action of the conically shaped distal surface of the stopper as it contacts the conically shaped inside surface of the distal wall of the barrel. Further, the projections should be positioned such that and/or structured so that when they are in a partially compressed state they are not alone capable of forcing the stopper proximally in the barrel to disengage the seal between the conically-shaped distal surface of the stopper and the barrel near the passageway.

[0033] Referring to FIGS. 1-6 and 8-12, another embodiment of the present invention includes a method of making a flush syringe assembly. The method comprises providing a plurality of barrels **22** including a cylindrical sidewall **23** having an inside surface **32** defining a chamber **33** for retaining fluid, an open proximal end **28** and a distal end **30** including a distal wall **31** having an elongate tip **36** extending distally therefrom having a passageway **38** therethrough in fluid communication with the chamber. The inside surface of the barrel at the distal wall is conically-shaped having a total included angle indicated by the letter A. The method further includes providing a plurality of stoppers **54** capable of being slidably positioned in fluid-tight engagement with the inside surface of the barrel for drawing fluid into and driving fluid out of the chamber of the barrel by movement of the stopper relative to the barrel. The stopper has a conically-shaped distal surface having a total included angle indicated by the letter B. The method further includes selecting a stopper from the plurality of stoppers and selecting a barrel from the plurality of barrels wherein the total included angle A of the inside surface of the

selected barrel at its distal wall is greater than the total included angle B of the selected stopper distal surface, and inserting the selected stopper into the chamber of the selected barrel so that the distal end of the selected stopper faces the distal end of the selected barrel. A wide variety of methods and/or devices can be used to
5 select barrels and stoppers based on the total included angle of the conically-shaped distal surface of the stopper and the total included angle of the inside surface of the barrel at its distal wall. These methods may include measuring and/or sorting the parts individually or statistically by known methods including but not limited to use of go/no-go gauges, optical comparators, optical inspection machines and custom
10 sorting devices all of which are known.

[0034] The method may further include, in any workable order, the steps of providing a plunger **24** including an elongate body portion **25** having a proximal end **50** and a distal end **52**, and attaching the distal end of the plunger to the proximal end of the selected stopper. The plunger may be attached to the stopper before the
15 stopper is inserted in the selected barrel or after. A tip cap **45** configured for releasable connection to the tip of the barrel for sealing the passageway may be connected to the tip of the selected barrel. A quantity of flush solution may be placed in the chamber of the selected barrel.

[0035] A variation of the method of the present invention for making a flush
20 syringe assembly includes the steps of providing a plurality of barrels **22** and providing a plurality of stoppers **54** as described hereinabove and selecting a stopper from the plurality of stoppers and a barrel from the plurality of barrels wherein the total included angle A of the inside surface of the selected barrel at the distal wall is greater than the total included angle B of the selected stopper distal
25 surface. The method further includes providing a tip cap **45** configured for releasable connection to tip **36** of barrel **22** for sealing passageway **38** and connecting the tip cap to the selected barrel. The method further includes placing a quantity of flush solution **71** in the chamber of the selected barrel and inserting the selected stopper in the chamber of the selected barrel so that flush solution **71** is
30 contained generally between distal wall **31** of selected barrel **22** and distal end **58** of the selected stopper. The method may further include a step of sterilizing the flush syringe assembly through a known method such as autoclaving, radiation.

sterilization and the like. The method may also include placing the syringe assembly in a protective package **73** and sealing the package.

[0036] Although the invention herein has been described with reference to particular embodiments, it is to be understood that these embodiments are merely
5 illustrative of the principles and applications of the present invention. It is therefore to be understood that numerous modifications may be made to the illustrative embodiments and that other arrangements may be devised without departing from the spirit and scope of the present invention as disclosed.

WHAT IS CLAIMED IS:

1. A method of making a flush syringe assembly having anti-reflux features which comprises:

5 providing a plurality of barrels including a cylindrical side wall having an inside surface defining a chamber for retaining fluid, an open proximal end and a distal end including a distal wall with an elongate tip extending distally therefrom having a passageway therethrough in fluid communication with said chamber, said inside surface of said barrel at said distal wall being conically shaped;

10 providing a plurality of stoppers capable of being slidably positioned in fluid-tight engagement with said inside surface of said barrel for drawing fluid into and driving fluid out of said chamber by movement of said stopper relative to said barrel, said stopper having a conically-shaped distal surface;

15 selecting a stopper from said plurality of stoppers and a barrel from said plurality of barrels wherein the total included angle of said inside surface of said selected barrel at said distal wall is greater than the total included angle of said selected stopper distal surface; and

20 inserting said selected stopper into said chamber of said selected barrel so that said distal end of said selected stopper faces said distal wall of said selected barrel.

2. The method of claim 1 further including the steps of:

providing a plunger including an elongate body portion having a proximal end and a distal end; and

25 attaching said distal end of said plunger to said proximal end of said selected stopper.

3. The method of claim 1 further including the step of:

30 providing a tip cap configured for releasable connection to said tip of said selected barrel for sealing said passageway; and

connecting said tip cap to said tip of said selected barrel.

4. The method of claim 1 further including the step of:
placing a quantity of flush solution in said chamber of said selected barrel.
5. The method of claim 1 wherein the total included angle of said inside surface
5 of said distal wall of said selected barrel is greater than the total included angle of
said stopper distal surface by at least 6°.
6. A method of making a flush syringe assembly which comprises:
providing a plurality of barrels including a cylindrical side wall having an inside
10 surface defining a chamber for retaining fluid, an open proximal end and a distal end
including a distal wall with an elongate tip extending distally therefrom having a
passageway therethrough in fluid communication with said chamber, said inside
surface of said barrel at said distal wall being conically-shaped;
providing a plurality of stoppers capable of being slidably positioned in fluid-
15 tight engagement with said inside surface of said barrel for drawing fluid into and
driving fluid out of said chamber by movement of said stopper relative to said barrel,
said stopper having a conically-shaped distal surface;
selecting a stopper from said plurality of stoppers and a barrel from said
plurality of barrels wherein the total included angle of said inside surface of said
20 selected barrel at said distal wall is greater than the total included angle of said
selected stopper distal surface;
providing a tip cap configured for releasable connection to said tip of said
selected barrel for sealing said passageway;
connecting said tip cap to said tip of said selected barrel;
25 placing a quantity of flush solution in said chamber of said selected barrel; and
inserting said selected stopper into said chamber of said selected barrel so
that said flush solution is contained generally between said distal wall of said
selected barrel and said distal end of said selected stopper.

7. A method of claim 6 further including the step of:
sterilizing said flush syringe assembly.

5 8. The method of claim 6 further including the steps of:
providing a plunger including an elongate body portion having a proximal end
and a distal end; and
attaching said distal end of said plunger to said proximal end of said selected
stopper.

10

9. The method of claim 6 further including the steps of:
placing said syringe assembly in a protective package; and
sealing said package.

15

FIG. 1

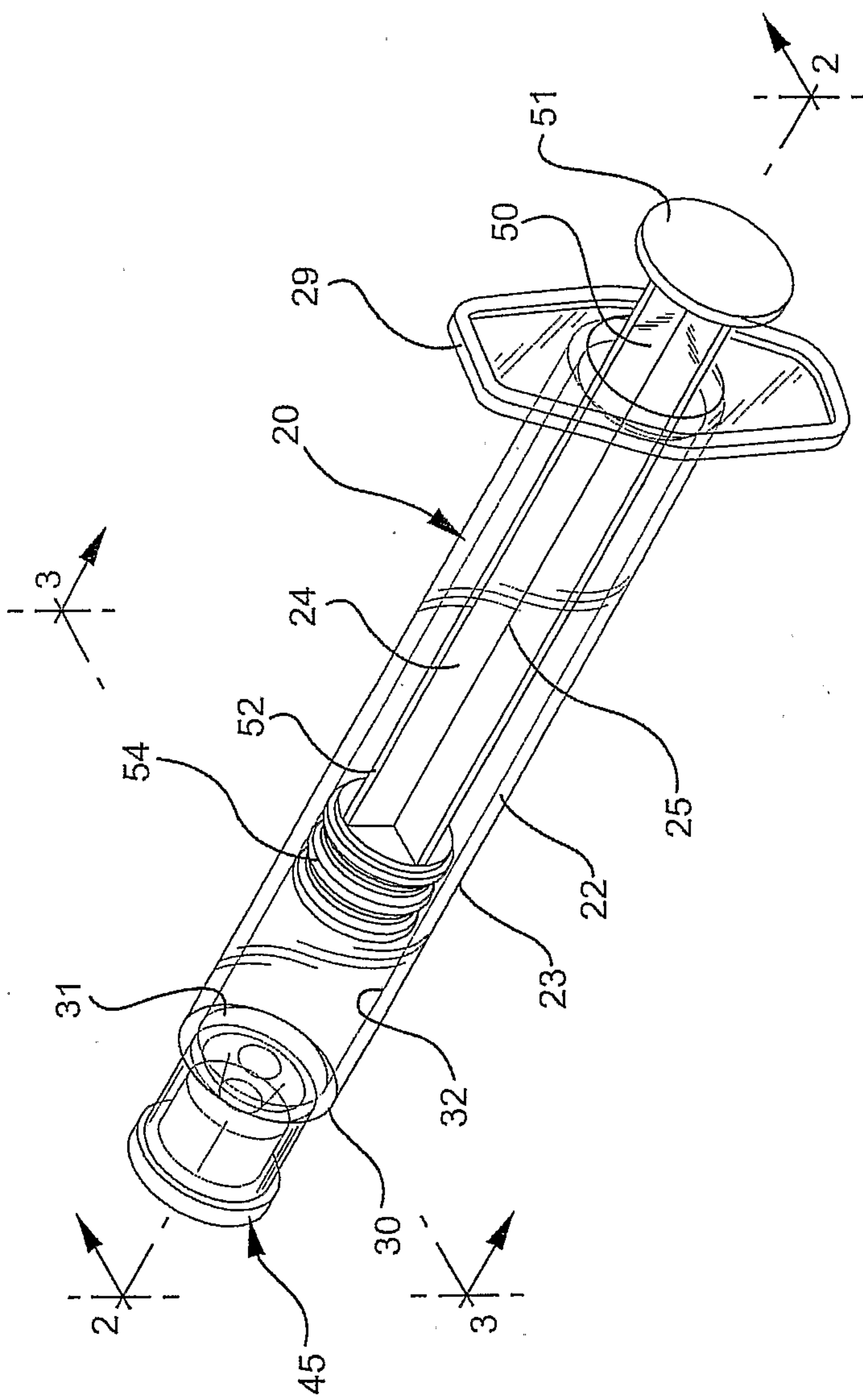

FIG. 2

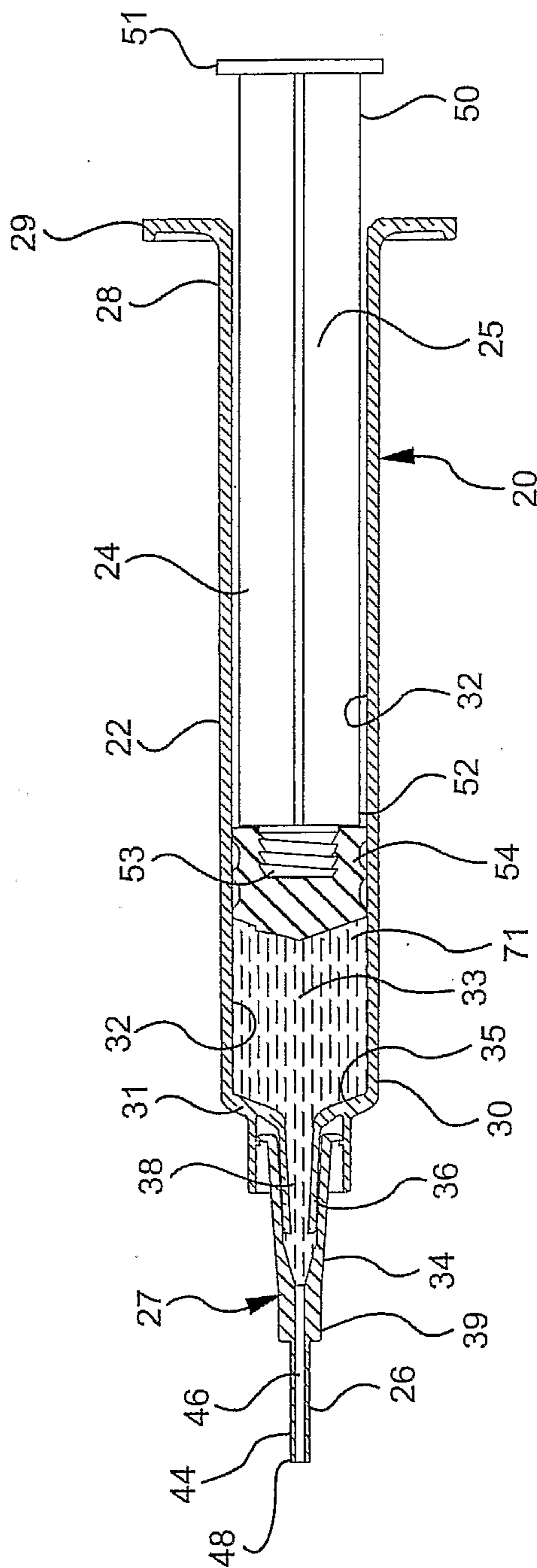

FIG. 3

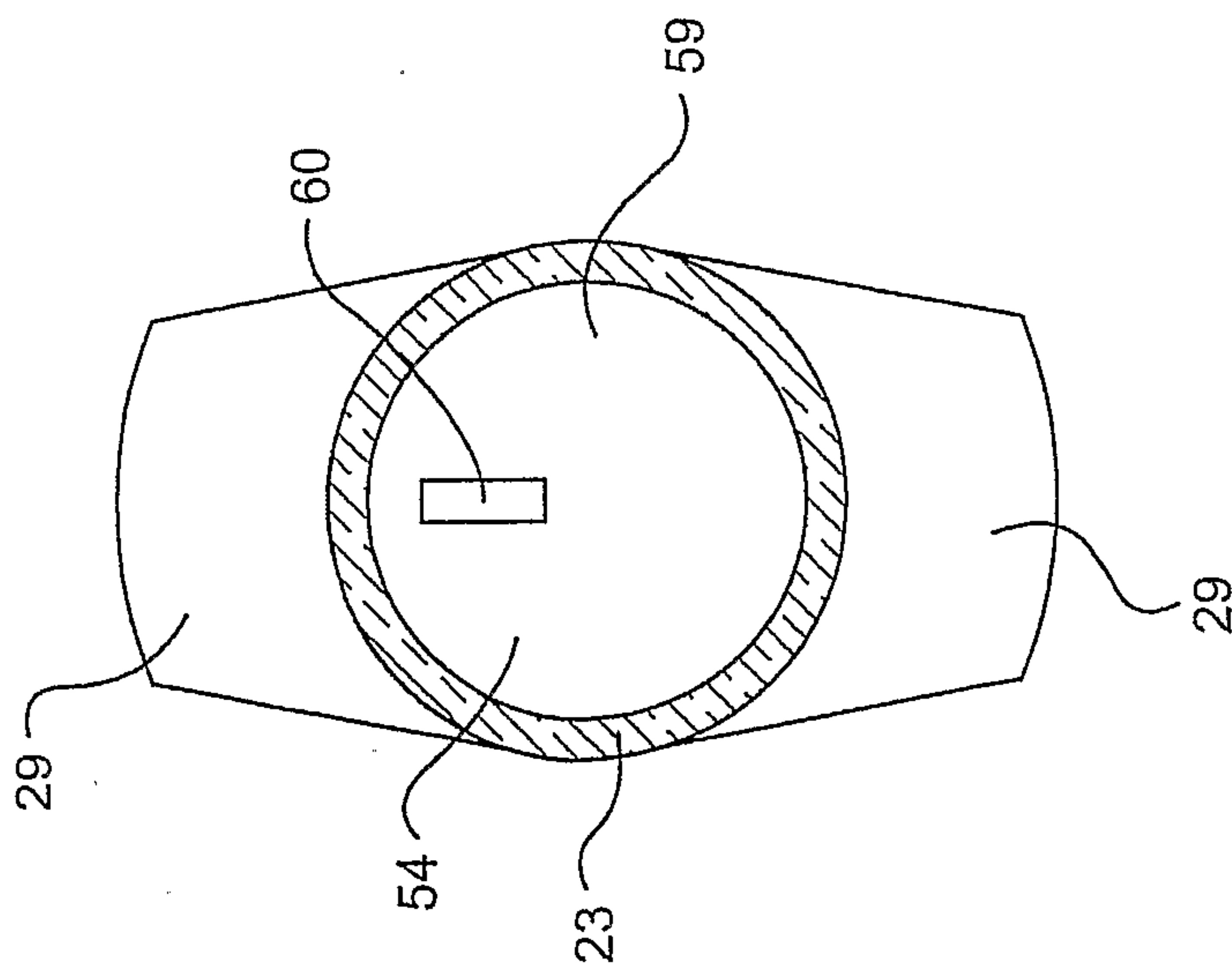

FIG. 4

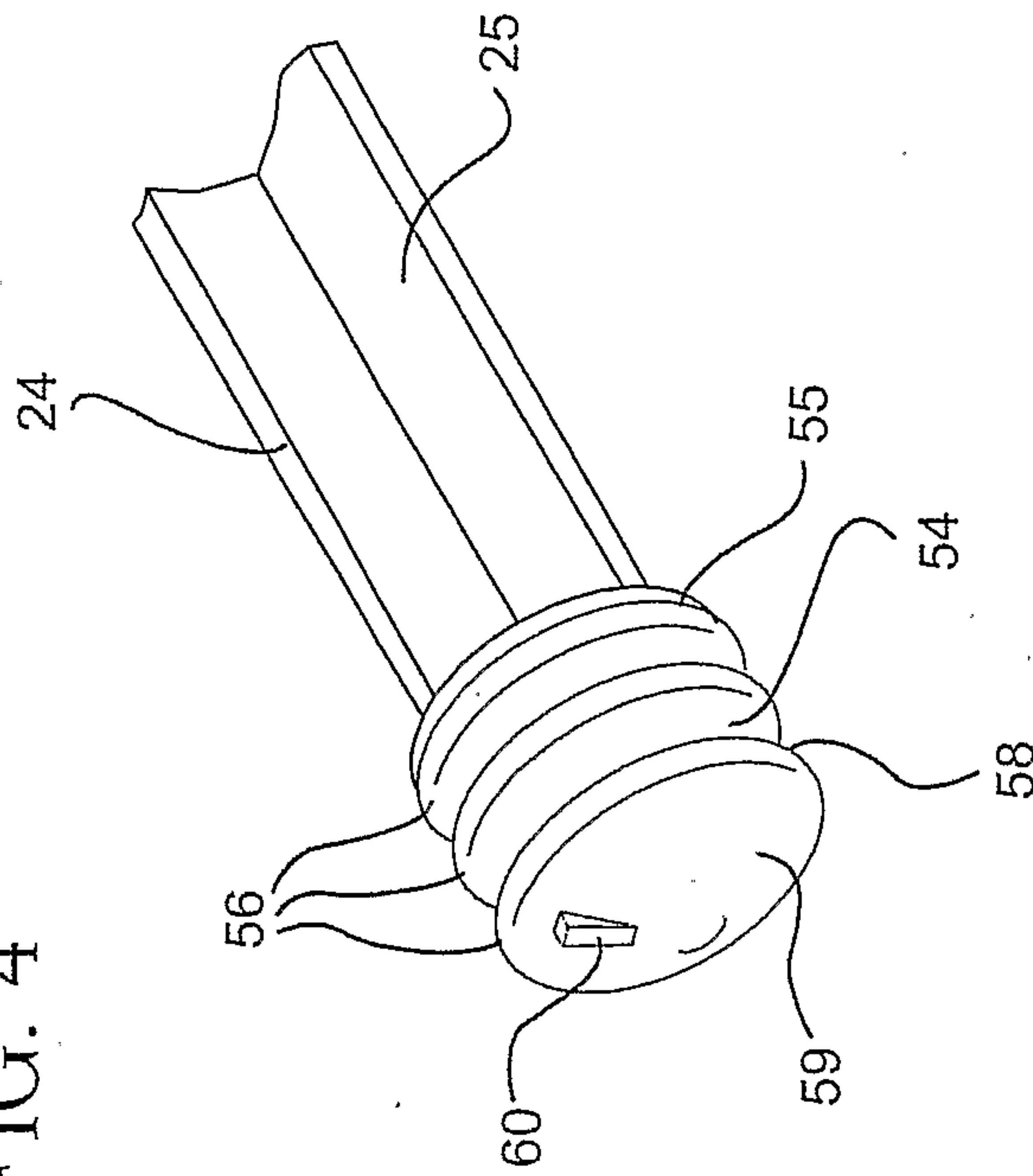
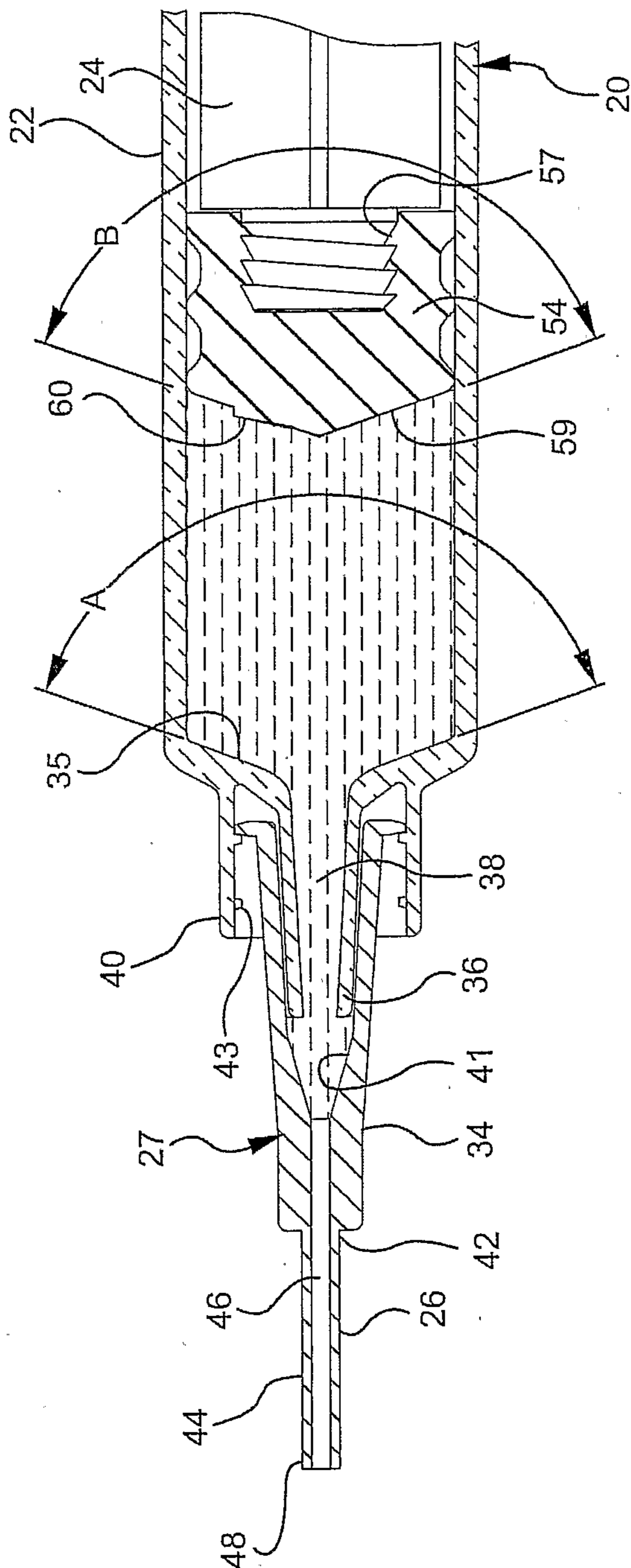

FIG. 5



5/11

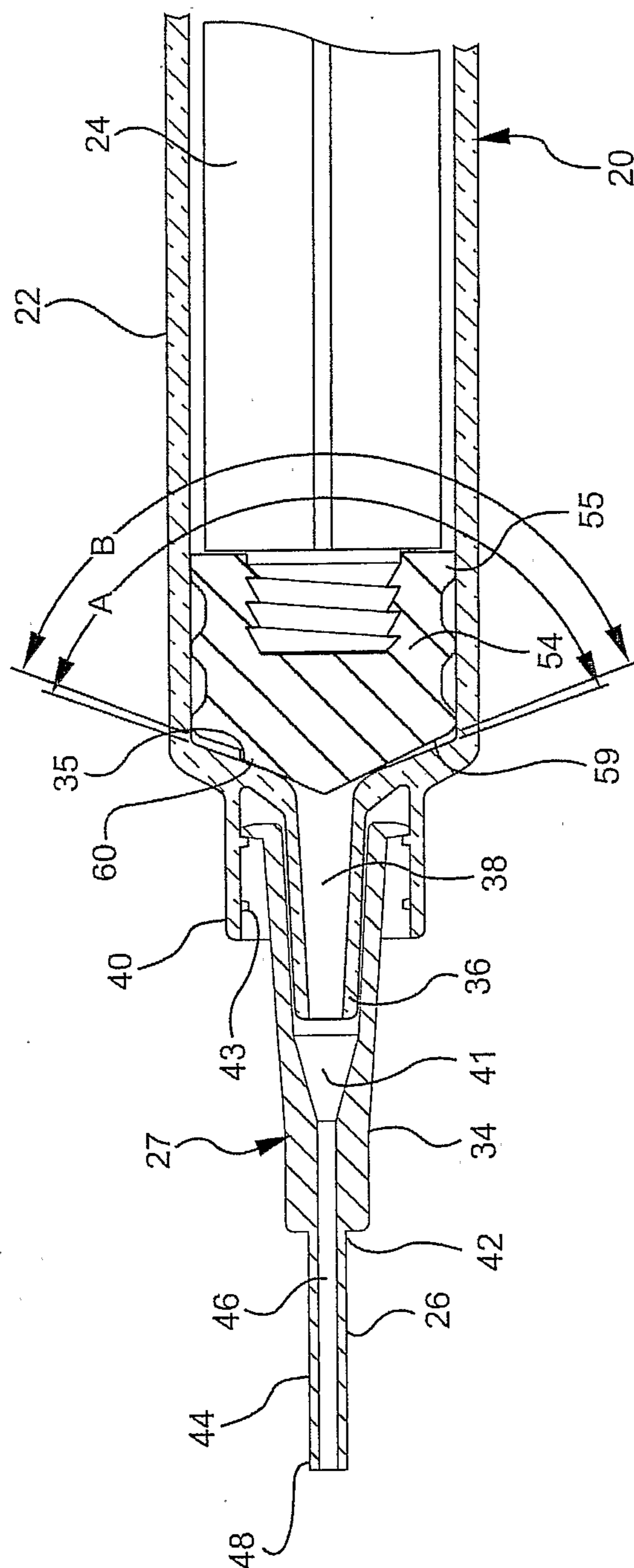

FIG. 6

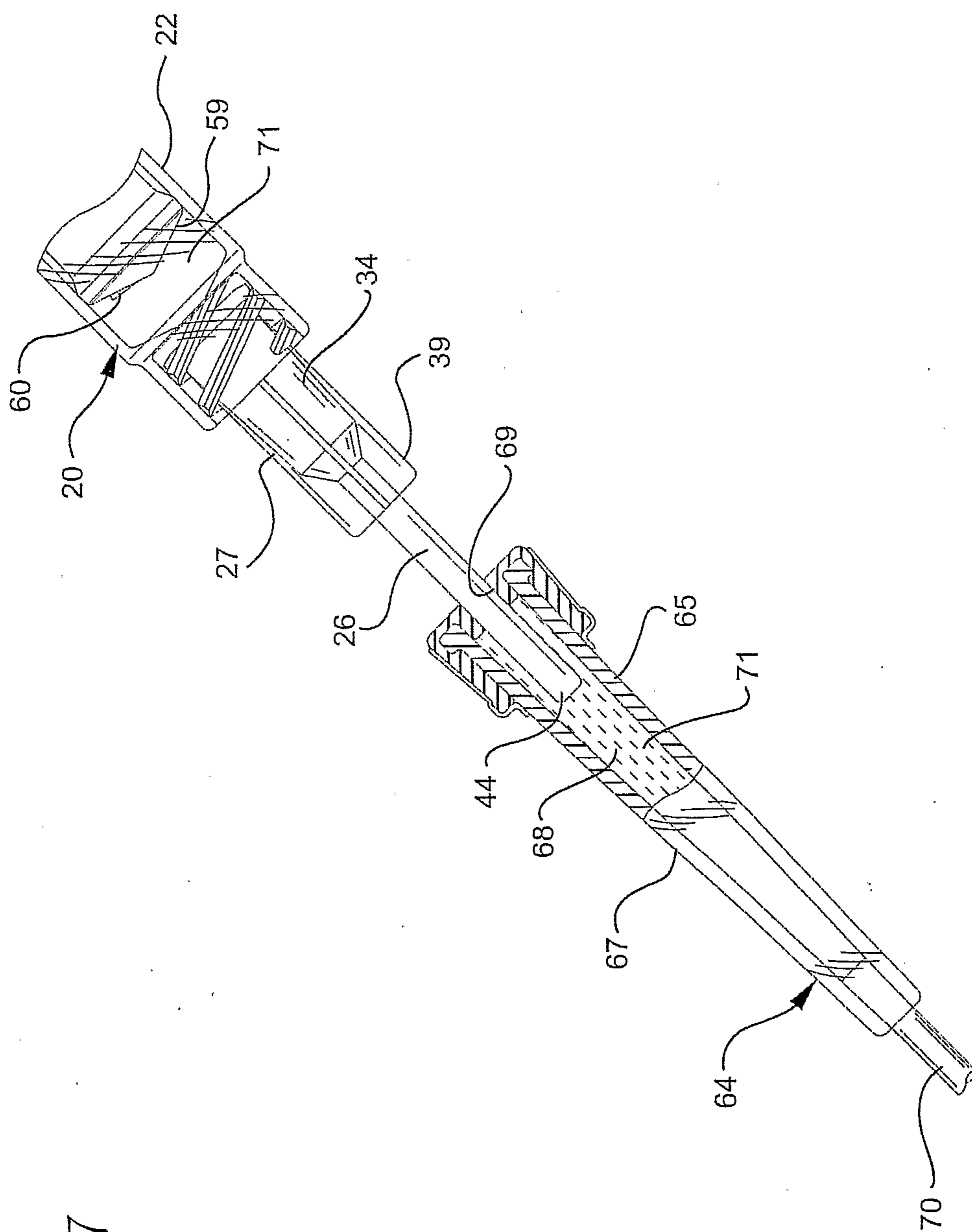
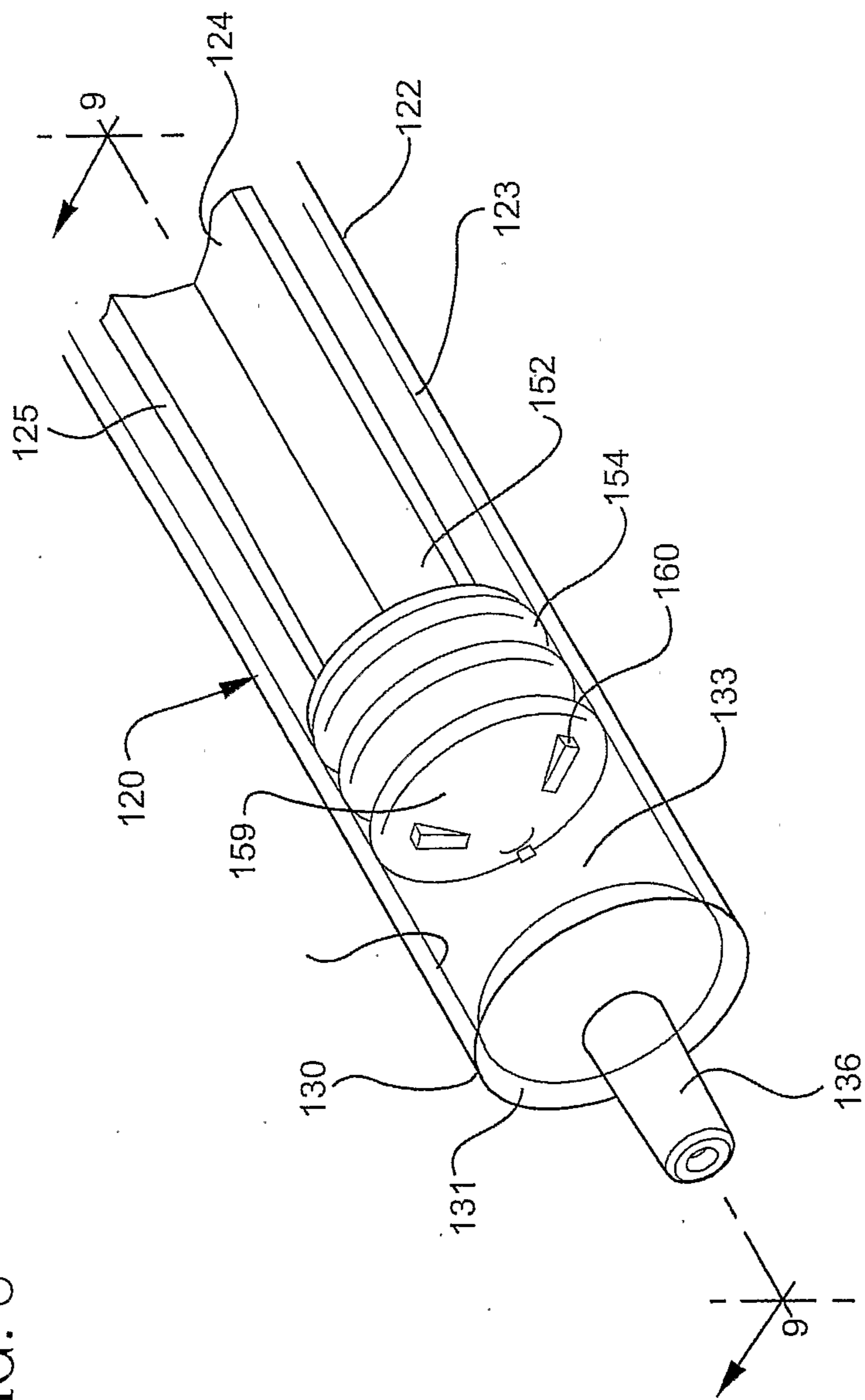

FIG. 7

FIG. 8



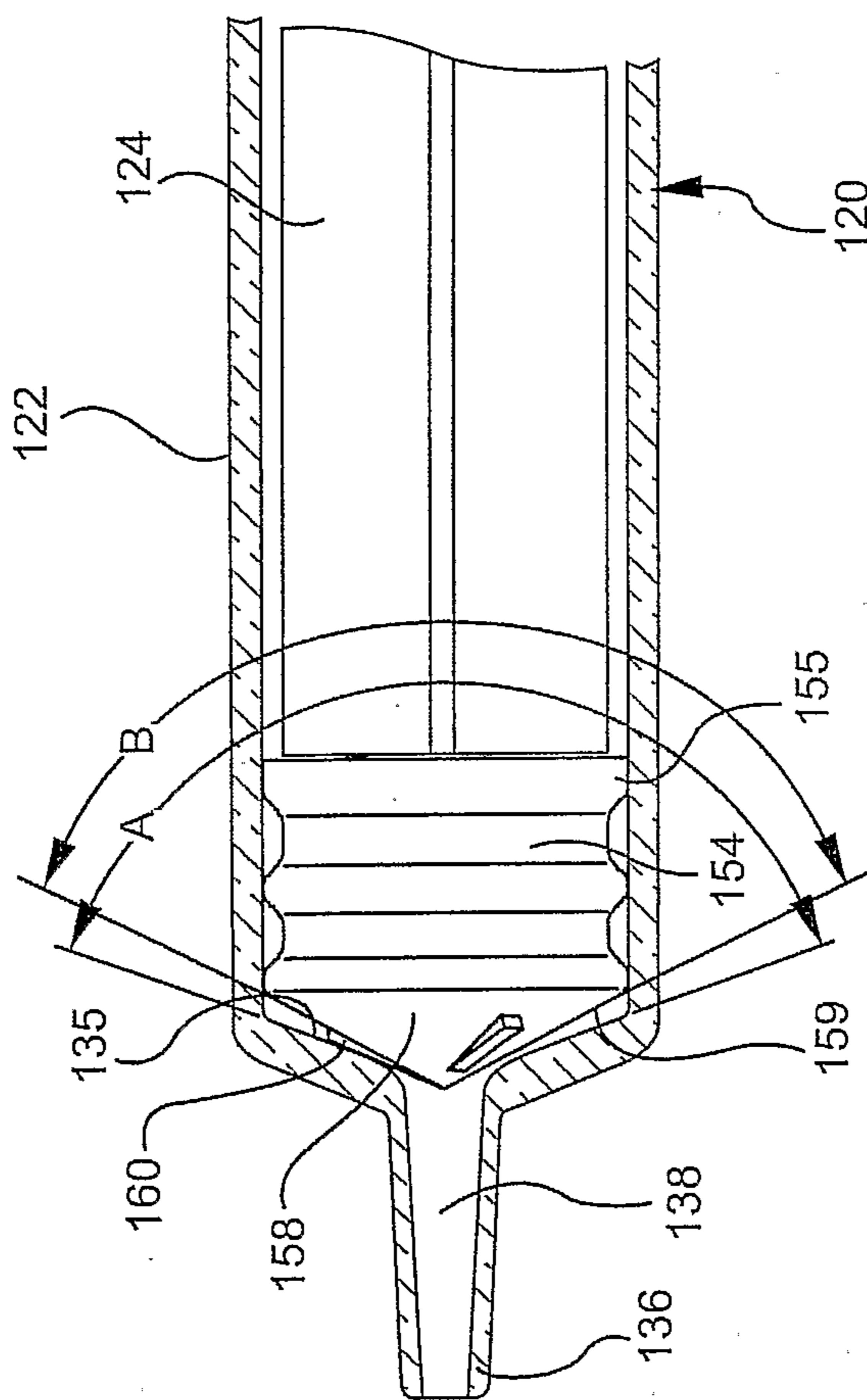
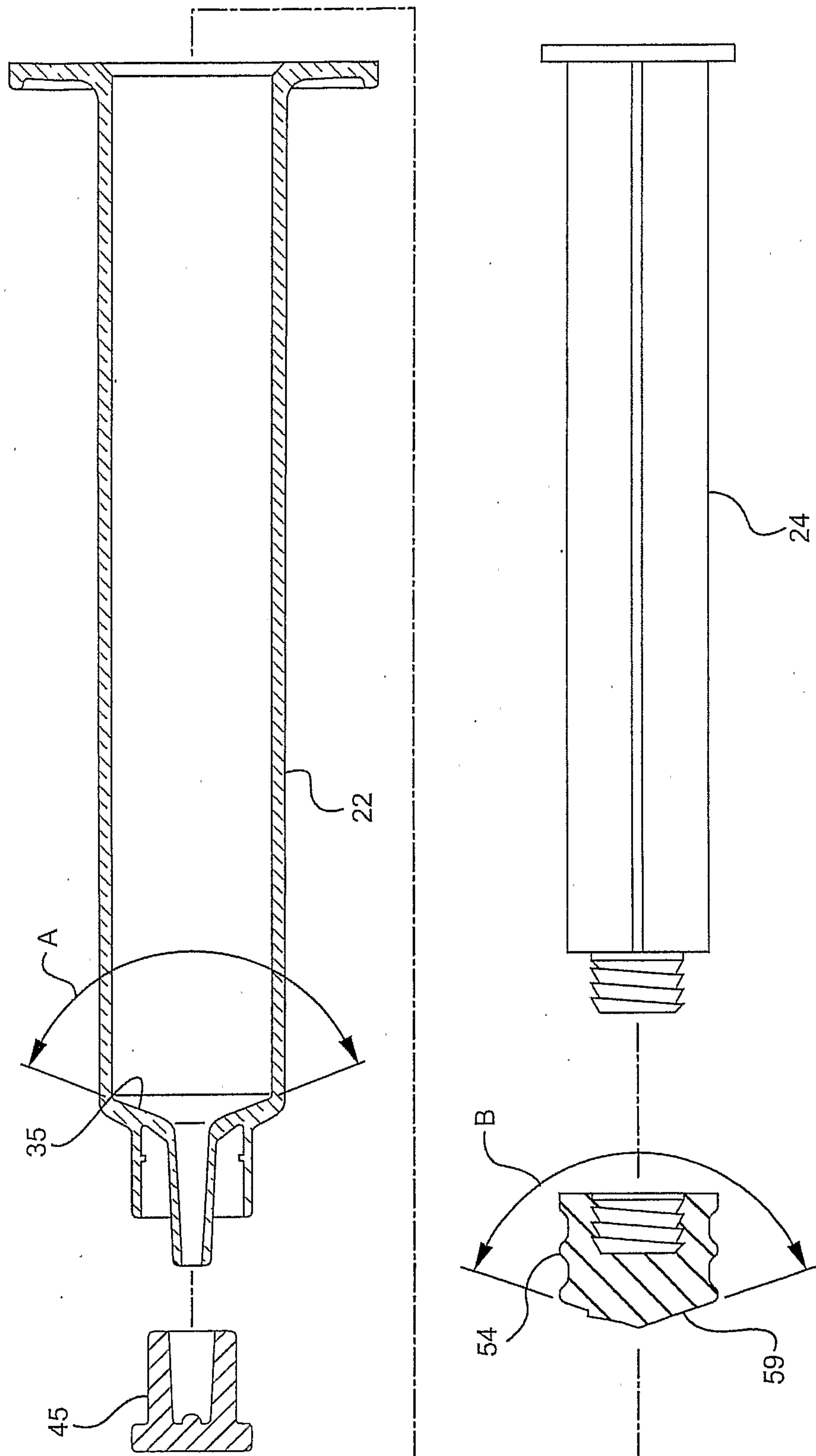

FIG. 9

FIG. 10



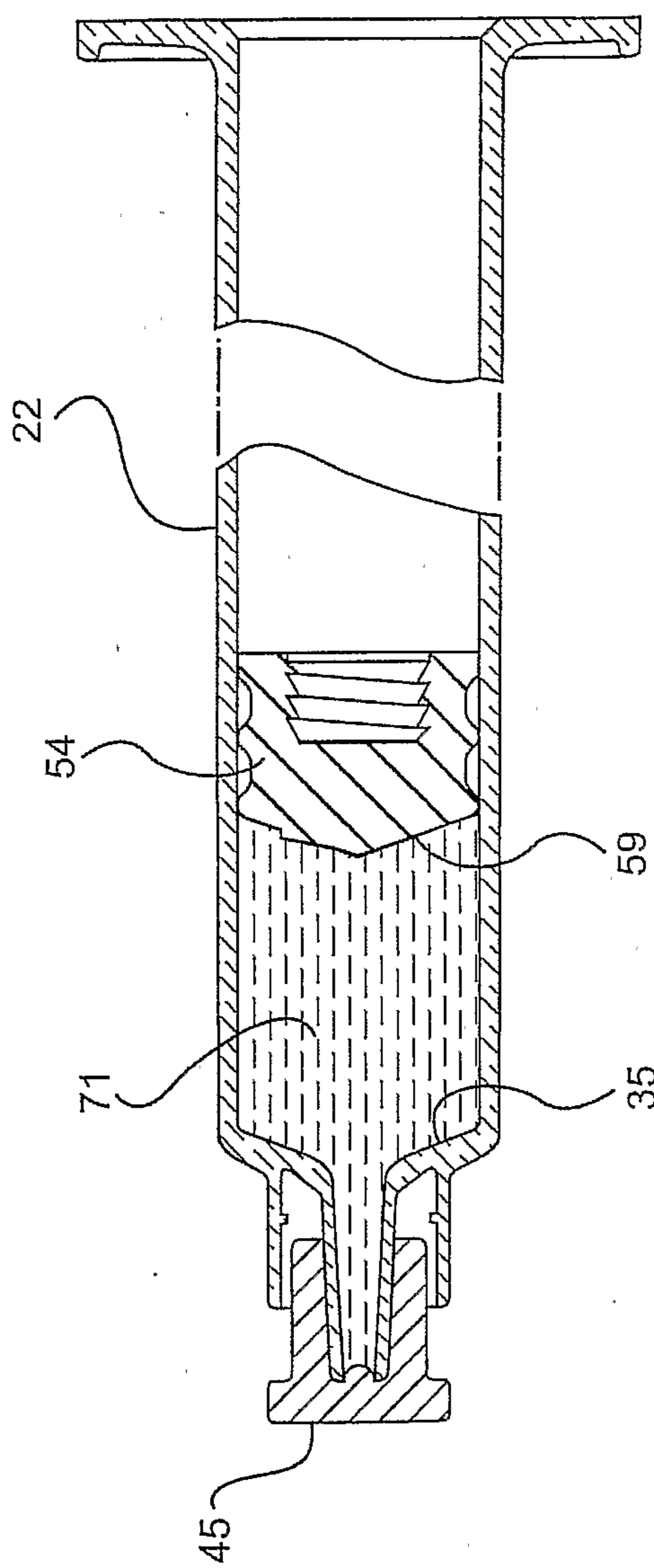

FIG. 11

FIG. 12

