

W. C. THAYER.

METHOD OF AND MEANS FOR PRODUCING COMPLETE COMBUSTION.

No. 299,877.

Patented June 3, 1884.

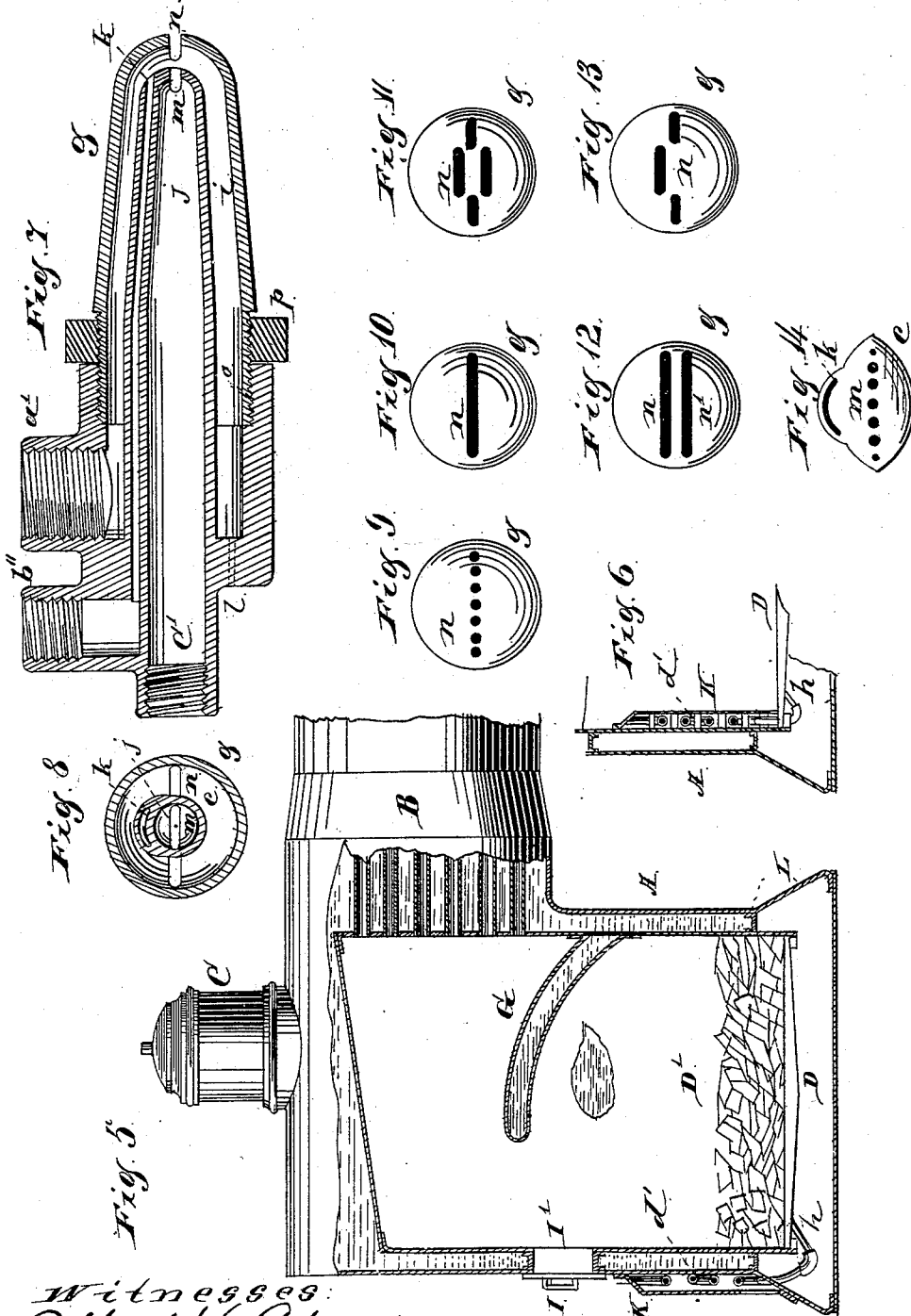

Witnesses:
 Albert H. Adams.
 Edgar D. Bond.

Inventor:
 William C. Thayer

W. C. THAYER.

METHOD OF AND MEANS FOR PRODUCING COMPLETE COMBUSTION.
No. 299,877. Patented June 3, 1884.

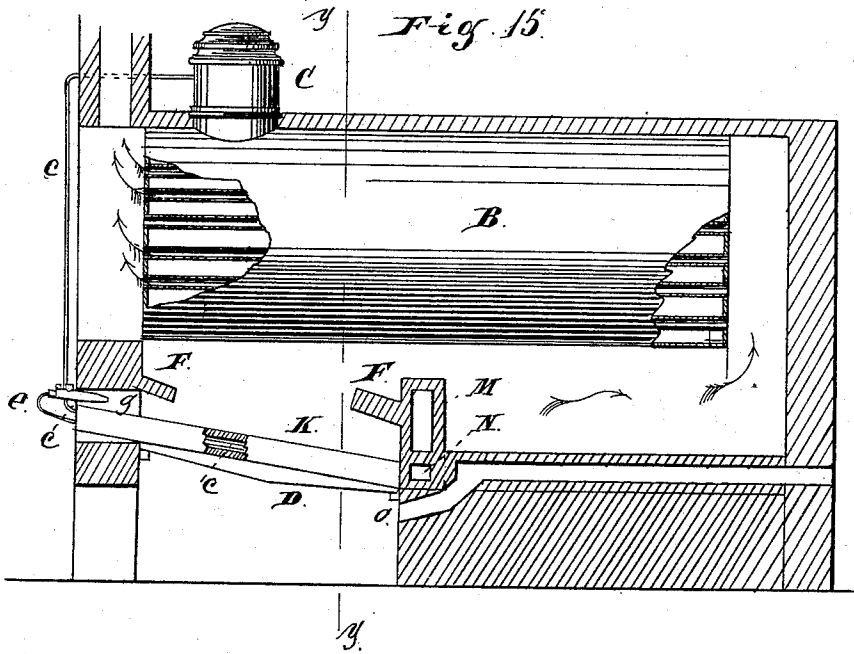
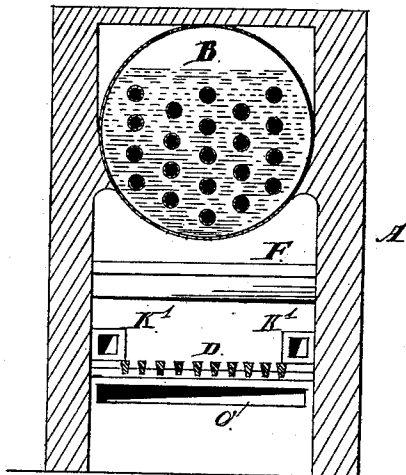

Fig. 16.



Inventor:
William C. Thayer

Witnesses:
Albert H. Adams,
Edgar S. Bond.

UNITED STATES PATENT OFFICE.

WILLIAM C. THAYER, OF CHICAGO, ILLINOIS.

METHOD OF AND MEANS FOR PRODUCING COMPLETE COMBUSTION.

SPECIFICATION forming part of Letters Patent No. 299,877, dated June 3, 1884.

Application filed June 23, 1883. (No model.)

To all whom it may concern:

Be it known that I, WILLIAM C. THAYER, residing at Chicago, in the county of Cook and State of Illinois, and a citizen of the United States, have invented certain new and useful Improvements in Means for and Methods of Producing Complete Combustion, of which the following is a full description, reference being had to the accompanying drawings, in which—

Figure 1 is a vertical section on line xx of Fig. 2; Fig. 2, a front elevation with the air-heating chamber partly broken away; Fig. 3, a detail showing the arrangement of pipes immediately beneath the fire-door; Fig. 4, a part of the inside sheet of the water-leg immediately below the fire-door; Fig. 5, the vertical section of a locomotive or portable engine, showing a modified form of the bridge-wall or water-leg and grate; Fig. 6, a broken section showing an air-heating chamber in the fire-box; Fig. 7, a vertical section of the injector; Fig. 8, a cross-section thereof; Figs. 9, 10, 11, 12, and 13, details showing the blast-openings of the injector with modifications; Fig. 14, a modified form of the end of the inner or steam portion of the injector and oil-passage; Fig. 15, a vertical section of a stationary furnace with the boiler partly broken away, and Fig. 16 a cross-section on line yy of Fig. 15.

My invention has for its object a new and improved method or mode of instantaneously decomposing and consuming steam in conjunction with carbonaceous material and air, with or without liquid hydrocarbon, by a continuous process, and instantly converting them into their resultant gases of hydrogen and carbonic-acid gas, (carbonic anhydride,) thereby making perfect combustion of the fuels and immediately preventing discolored smoke, resulting from combustion, for the production of heat in furnaces, steam-generators, for smelting ores, for making illuminating-gases, and in all the arts. A method heretofore employed has been to use retorts, and the burning of liquid hydrocarbon, to heat them sufficiently to decompose the steam, on the theory that by decomposing the steam or water some heat units would be gained; but with a partial decomposition of the steam there was more loss than gain. Steam has been used as an easy way of getting liquid hydrocarbon into

the retorts or furnaces, but at a loss as compared with the cost of the heat units required for doing the work; and by this method the liquid hydrocarbon becomes simply an excess, so that all attempts have been found impracticable in use, notwithstanding the fact that the heat units of the liquid or hydrocarbon were nearly all obtained, and in the best-known appliances for burning solid carbonaceous material only a part has been obtained, as from twenty-five to seventy-five per cent., according to the purposes applied to, passes off as a loss. Many attempts have been made to utilize liquid hydrocarbon, in conjunction with steam and carbonaceous material, by using the steam as a projector or force to convey liquid hydrocarbon into the fire-box, using the carbonaceous material as a foundation for improving or supporting combustion; and in these appliances, as soon as the carbonaceous material was ignited, the dampers of the ash-pit were closed, or other means used, to shut off the draft or air, to check the consumption of coal, thus depending on the liquid fuel for continuing the combustion. All of these devices have also been found impracticable. Steam has also been injected into fire-boxes when carbonaceous material was burning, and where the draft was faulty this has aided it somewhat, as a better combustion was obtained; but it has been at an expense rather than a gain, for, unless steam is decomposed, it is an injury to the fire, and requires just that much more carbonaceous material to overcome the loss caused by the steam, which has deadened down and cooled off the fire; but the steam, uniting with the smoke, increased its volume, and thus changed the color of the smoke to a lighter hue, or made it less dense, although the unconsumed combustible gases might be greater than before; hence these devices have been found impractical in use. Water-gases are being practically produced for illuminating purposes by the intermittent process, which uses, first, a blast of air to bring the carbonaceous material up to white heat; then the air-blast is stopped and the steamed liquid hydrocarbon let on till the materials deaden the coal so that it will no longer decompose them, when they are turned off, and the air-blast is again put on. This method produces

gases, which are purified and stored for use. My invention is designed to obviate the heretofore known objections and provide the means to overcome them. I have discovered and found by practical experiments and use the means whereby the difficulties heretofore experienced in improving combustion and preventing the formation of smoke are overcome by new devices and new combinations of devices; hence new chemical results or new methods. When I employ liquid hydrocarbon at all it is only when the fire is first started or needs quickening, and because liquid fuel is quickly ignited. When used, I let a small quantity flow into the injector in a chamber passing along the steam-pipe or spindle of the injector. It becomes highly heated and more readily unites with the other gases, promoting combustion. I have discovered that steam, in conjunction with air and burning carbonaceous material, either with or without liquid hydrocarbon, may be instantly and continuously decomposed and its hydrogen and oxygen separated and recombined into their resultant gases or vapors of water. Carbonic oxide and carbonic acid, if impinged and brought into sharp contact and instantaneously mingled and mixed with, substantially, every particle of the available carbonaceous material in fine subdivided broad sheet or sheets, so that every atom, as nearly as may be, is thoroughly distributed over, into, and through the surface of the carbonaceous material, making a constant blast against the carbonaceous material, will bring the same to white heat, and produce substantially perfect combustion of all the fuels and combustible gases, and make a pure and intensely-hot fire—a result that has not been heretofore obtained.

My invention further has for its object the means for producing perfect combustion of all kinds of carbonaceous material, and especially the poor grades or qualities—such as slack and coal-dust—that have but little use, thereby securing greater economy; and I do this by properly distributing finely-subdivided sheet or sheets of coal-dust and steam in conjunction with air, and mixing them with the superimposed gases, and over and through the surface of the carbonaceous materials.

My invention further has for its object means for decomposing steam and separating the hydrogen from the oxygen by supplying the burning carbon with sufficient oxygen and freeing the hydrogen.

It has the further object of furnishing the means of supplying the air to the steam and carbonaceous material and liquid hydrocarbon, when used, and means for heating the air when desired, by passing steam-pipes through boxes, either inside or outside the fire-box, the steam serving the purpose of thus heating the air as it passes to and out of the injectors underneath the grate-bars, where it takes in air and passes up through and mingles with the burning carbonaceous material.

It has also for its object a new and improved construction and operation for the injector, whereby it may subdivide the steam and air, and hydrocarbon, when used, into fine broad sheet or sheets, so that every particle may be spread over and through the entire fire-box or furnace, and so distribute the same that every particle may be brought into intimate contact with the carbonaceous material and take in coal-dust by induction from or through the injector. When fire is first started and under way, and before there is any steam-pressure, a small amount of water is allowed to pass into the steam-pipe, and it is then converted into steam, so that almost immediately I begin with the blast-fire.

The nature of my invention consists in the processes and means for carrying out the stated objects, as hereinbefore and hereinafter described, and claimed as new.

In the drawings, A indicates the water-space around the furnace or the furnace-walls; B, the boiler; C, the steam-dome; D, the grate-bars; D', the furnace or fuel-space; E, water-tubes; F, bridge-wall or bridge-slab; G, water-leg; H, pipe or pipes leading from the water-leg to the crown-sheet; I, door; I', door-space; J, the steam-box, sometimes called the "soda-fountain;" K, air-heating box or chamber; L, ash-pit doors; M, N, and O, air-passages; *a*, coal-dust pipe; *b*, oil-pipe; *b'*, branch oil-pipe; *c*, *d*, steam-pipes; *e*, branch of steam-pipe leading to the upper injectors; *f*, branch pipes connected with the injectors; *g*, injectors; *h*, lower injector; *i*, coal-dust space within the injector; *j*, steam-passage; *k*, oil-passage; *l*, air-passages; *m*, *n*, blast-openings; *o*, screw-coupling for the outer shell of the injector; *p*, lock-nut for holding the screw *o* to its adjustment; *r*, pipe for connecting the steam-pipe *c* with the water of the boiler; *s*, valve or cut-off; *a'*, *b'*, *c'*, couplings for their respective pipes with the injector *g*; K', modified forms of heating-chambers.

The locomotive or portable boiler can be made in the form shown at either Figs. 1 or 5, the form shown at Fig. 1 being the one preferred. The fire-grates D and fuel-space D' are or may be of the usual construction, and the fire-space is provided, as shown, with water-pipes E, bridge wall or slab F, and the water-leg G, which is here shown connected with the crown-sheet by pipes H, which pipes are omitted in Fig. 5; and in both of the forms shown the water-space or water of the leg G has free communication through the side plates of the fire-box, to allow the escape of generated steam and a circulation of water, to prevent burning it out. The water-tubes E, having an inclined position, gives a circulation for the water and steam, which also prevents them from being burned out. The boiler B is a flue-boiler of the ordinary construction, or of any suitable construction. The steam-dome shown is the one usually found on locomotive-boilers. The feed-opening I', with the door I, are also of any

ordinary or suitable construction. The steam-pipe *c* is arranged to take steam from the dome by leading it inside of the boiler into the dome, as indicated in Fig. 1, or from the outside, as shown in Fig. 15, the form shown in Fig. 1 being preferred for locomotive or portable boilers. In this form the box or fountain J is interposed, as shown in Figs. 1 and 2, and the steam-pipe leads from this box down to a point below the water-door; or it passes through the heated fire-box, and then horizontally to a point nearly or quite midway between the sides, as shown in Fig. 2, when it again passes to the outside and down to the branch or cross pipe *f*, through which it connects with the rear ends of the injectors *g*. A second steam-pipe, *d*, leads from the box J down to and into the air-heating chamber K, where it is bent with any suitable number of bends, as shown at Fig. 2, and from this chamber the pipe leads to the rear end of one or more of the injectors *h*, located beneath the grate-bars. These injectors *h* are similar in their construction to the injectors *g*, except that there is no coal-dust pipe connected with them, and the oil-pipe may also be omitted, if desired. With these exceptions they are similar to the injectors *g*, which are hereinafter more fully described. The air space or chamber K is made by covering the coils of pipe *d* so as to leave an air-space for the contained air to be heated by the passing steam and the furnace heat. The form shown is square or angular, but the pipes may be coiled circular, and this chamber may be circular in front view, instead of angular. The air heated in this chamber is made to pass through the injector *g* from the induced current passing through the passages or openings *l*, (shown in Fig. 7,) but the main body or portion of it passes into the fire-space around the injector, and through the opening made for its insertion, as shown in Fig. 1. As shown, the doors of the ash-pit L are made in front; but by shortening the air-chamber K somewhat they may be placed in the rear, or they may be placed both front and rear.

For the purpose of using hydrocarbon or other suitable oil in first starting the fire, I apply to my apparatus the pipe *b*, which is connected with an oil reservoir or can located in any suitable position, and provided with a valve or cut-off to regulate or stop the flow of oil, and the pipe leads down, as shown in Sheet 1, to a branch or cross pipe, *b'*, which connects the pipe *b* with the two upper injectors shown, that being the number shown; but a single injector, or a greater number, may be used; and in case a greater number is used additional couplings will be used to make the proper connections. These oil-pipes connect with each injector by the coupling *b''*, (shown in Fig. 7,) through which it connects with the oil tube or duct *k* of the injector.

As a part of my improvement consists in feeding in coal-dust through or by means of the injector, I provide the furnace with a pipe

or tube, *a*, for this purpose. As shown in Fig. 1, this pipe leads off horizontally to any suitable receptacle for containing coal-dust. In practice, however, this receptacle will be located on the top of the boiler, so as to avoid bending the pipe as much as possible. If a bend is necessary, I prefer to make it at an angle rather than as nearly horizontal, as shown. This tube should be made large enough to prevent the coal-dust from stopping or clogging within it, and it leads down to the top of the injector and connects with it at *a'* and with the space *i* in the injector, as shown in Fig. 7. The descending coal-dust partly fills this space *i*, and as the superheated steam is blasted through the injector a current of air is induced through the openings *l*, which current carries the coal-dust to the opening *n*, from which opening it is blown or blasted into the furnace. The injector *g* is made of brass or other suitable material, and the part containing the couplings and the steam and oil passages are usually cast in one piece. The outer shell is provided with a screw-thread, *o*, and screwed into the casting until the openings *m* and *n* are in their proper relation to each other, when it is locked by the nut *p*. By this arrangement the distance between the openings *m* and *n* may be adjusted to a greater or less distance apart, as may be found most convenient for the furnace in which it is placed. The openings *m* may be a single slit, as shown in Fig. 7; or it may be a row of perforations, as shown in Fig. 14; and instead of being circular in cross-section, as shown in Fig. 8, the device may be oval, and the interior tube or shell may have the form shown at Fig. 14. The openings *m* and *n* should always correspond, so that when the openings *n* are made according to the modifications shown in Figs. 10, 11, 12, and 13 the openings *m* will correspond in location and form, but are less in size; and when used for injecting more or less coal-dust the forms shown in these last-named figures are preferable. These openings are made in the form shown, for the purpose of throwing an inclined or horizontal stream over and across incandescent coal in thin strata or sheets, in one or more layers, Figs. 7, 8, and 10 showing the single sheet, Fig. 11 showing a sheet broken into four parts, Fig. 12 two equal overlapping sheets, and Fig. 13 three sheets, two at one elevation and one at an elevation slightly higher. These sheets at different elevations are designed to produce eddies and different currents within the fire-space, to permit a more thorough mixture of the injected matters and materials over and along the surface of the coal. If, however, the fuel in the fire-box is maintained at the proper height at all times, a single sheet or stratum of injected material will be found sufficient. When I use only two injectors above the fuel, I locate each about one-fourth of the distance across the fire-box away from the walls, so that the two streams, spreading one-fourth each way, will meet in the mid-

dle, and thereby cover nearly or entirely the whole surface of the fuel. I prefer to have my injector strike the fuel as near to them or the back of the fire-place as is practical, as I there-
 5 by blast the superheated steam and carbonaceous material over and along the surface of the fuel. The steam passing to the injectors *g* is superheated in and by the pipe *e*, which is inside of the fire-box. This pipe *e* may be
 10 provided with projections for holding the asbestos cement or other refractory material, to prevent its being burned out or damaged. Steam at two hundred and sixty degrees I regard as superheated, and for this reason the
 15 pipe *d'* is not shown as entering into the furnace; but it may be made to pass into and through the furnace; or the pipe *e* may be enlarged, so as to connect it therewith, if desired, and give the steam which passes to the injector *h* an additional heating; but ordinarily this will not be necessary, as the steam which passes in this injector mingles with the air of the draft and becomes so immediately incorporated with the fuel that it is burned
 20 without difficulty. I have shown but one injector, *h*; but others may be employed if desired; and the employment of additional ones will depend upon the size of the furnace or the use to which it is to be adapted. For a furnace of the size used in an ordinary locomotive one will be found sufficient.

When the air-heating chamber is located within the furnace, as shown at Fig. 6, there will be sufficient heat from the fire-box to impart some additional heat to the steam; and for locomotives this location will be found desirable, while for stationary or other traveling engines the exterior location will be sufficient; or this chamber may be divided into
 35 parts *K'* and located at the sides, as shown in Figs. 15 and 16. In the arrangement there shown for stationary engines the steam-pipe passes through the air-chambers *K'* and returns to the injector *g*. The air-chambers in this construction may have three sides embedded in the brick-work or masonry, so as not to interfere with the furnace-room, and also to retain the high heat of the masonry.

In adapting my improvement to the stationary form of boiler, as shown in Figs. 15 and 16, the passage *O* is provided for heating a portion of the air as it comes to the ash-pit when the ash-pit door is open, or nearly all of the air when the ash-pit door is closed.
 55 The location of the heating-chambers *K'* at the sides of the furnace will not so occupy the furnace-door as to interfere with the feeding in of the fuel. The bridge-wall *F*, here shown, is added to the ordinary bridge-wall, and is made of fire-brick or fire-slab, while the vertical portion is provided with a passage, *M*, in which an additional injector or injectors may be placed, to operate at the opposite end of the grate and under the projection *F* of the
 60 bridge-wall. The bridge-wall is also provided with an air-passage, *N*, which connects with

the air chambers or passages *K'*, so as to permit a circulation of air through or within them. A projection, *F'*, may also be applied to the front of the furnace, to aid in spreading and
 70 giving direction to the blast from the injectors. Where several boilers are used together, or where one or more boilers are used in positions requiring a blower, the blower may be connected with the passages *N* and *O*, for discharging a sufficient quantity of heated air to the furnace.

It will be obvious that where only one furnace-injector, *g*, is used, that it will not only be located midway of the width of the furnace, but also that the branch pipes *b'* and *f* will be omitted, and that direct connection will be made. It will also be further obvious that when the construction of the furnace renders the application of the heating-chamber *K* undesirable or impracticable, the bending or coiling *d'* of the pipe *d* will be omitted and a direct connection made with the lower injector, *h*.

The operation of these devices will be obvious from the description, and it will be seen that by their use I not only greatly improve the combustion of the fuel, but I produce a very high heat, and consume whatever smoke may have been formed in passing the air and steam through the body of the coal by the operation of my apparatus on the surface; but the main operation is to prevent the formation of visible smoke instead of consuming it after it is formed, as the result of my apparatus is to form complete combustion on the upper surface of the fuel. In the apparatus heretofore used a part of this result has been obtained; but in no case has it heretofore been complete. Smoke is formed by imperfect
 95 combustion, and in passing the air, or air and steam, through a body of fuel in the first layer of the fuel, so to speak, the combustion is perfect; but as the products of combustion mingle with the air, depleted forms of oxygen rise up through the body of the coal in the second stages of combustion, the oxide of carbon, which is a product of incomplete combustion, is formed, and after having passed through the body of the fuel there is no means for re-combining it with sufficient oxide to cause its re-combustion. This is especially true when fresh fuel is placed in the furnace. By my apparatus complete combustion is organized above the body of the coal, and upon the introduction of fresh coal perfect combustion occurs or takes place over it instantaneously; therefore, whatever of carbonic oxide may have been formed from the under combustion, and whatever may be formed by reason of the vitiated atmosphere of the fire-space, is instantly brought into connection with fresh oxygen from the steam from induced air-currents, and in the decomposition of steam hydrogen is also furnished too rapidly, or combines with the high heat, so that there is no fuel wasted, either in the form of unconsumed combustible gas or in

partly-burned fuel—such as carbonic oxide—
and by the arrangement of my apparatus this
superimposed or secondary combustion covers
the entire surface of the fuel, so that nothing
escapes, as has been and is the case with the
attempts heretofore made to produce perfect
combustion having no visible smoke.

By the use of the described means the steam,
air, coal-dust, and hydrocarbon (when used)
are largely heated by waste heat, so that when
they are mingled and come in contact with
the main body of burning fuel they each and
all tend to promote combustion in a practical
and efficient manner, and with better results
than have heretofore been obtained, and the
arrangement of the parts is such that neither
one nor all of these parts together in any way
obstruct or injure the ordinary operations of
the furnace or the burning of the solid fuel
when all or any one of them are thrown out
of operation by accident or design.

What I claim as new, and desire to secure by
Letters Patent, is—

1. The combination, with the furnace and its
boiler, of the steam-pipe *c*, leading from the
dome of the boiler to the box *J*, and thence
downward along the outside of the furnace, the
superheating-tube *e*, connecting with pipe *c*,
and extending across the inside of the fire-box,
and thence to the outside and downwardly to
the pipe *f*, contained within the air-chamber *K*,
and the injector connecting with said pipe *f*,
substantially as described.

2. The combination, with the furnace and its
boiler, of the steam-pipe *c*, leading from the
dome of the boiler, the superheating-tube *e*,
connecting with pipe *c*, and extending trans-
versely across the inside of the fire-box and
then to the outside thereof, the pipe *f*, inside
the heating-chamber *K*, and connecting with
the pipe *e*, the injector having a steam-passage
connecting with pipe *f*, and an oil-passage out-

side of the steam-passage, and an oil-tube con-
necting with said oil-passage, substantially as
described.

3. The combination of the steam-pipes *c e*,
oil-pipe *b*, dust-pipe *a*, the injector above
the grate-bars, provided with the steam, oil,
and dust passages communicating with said
pipes, the steam-pipe *d*, and the injector below
the grate-bars, communicating with said pipe
d, substantially as and for the purpose set forth.

4. The combination of the steam-pipes *c e*
and the injector above the grate-bars, with the
steam-pipe *d*, having the returns *d'* within the
chamber *K*, and the injector below the grate-
bars, substantially as and for the purpose set
forth.

5. The injectors composed of the casting
having the steam-passage and portion of the
dust-passage formed in one piece therewith,
and the outer shell adjustably secured to said
casting, and held in place by the lock-nut,
whereby the space adjustment between the
blast-exits of the steam and dust passages and
the alignment of such exits are preserved,
substantially as and for the purpose set forth.

6. The method herein described of produc-
ing complete combustion and preventing the
formation of visible smoke, consisting in in-
jecting superheated steam, finely-divided car-
bonaceous material, and air in a broad sheet
over the surface of the burning fuel, and at the
same time injecting superheated steam and air
under the body of the burning fuel, substan-
tially as and for the purpose set forth.

7. The combination, in a steam-generator
furnace, of the water-tubes *E*, fire slab or bricks
F, and water-leg *G*, with injectors, substan-
tially as specified.

WILLIAM C. THAYER.

Witnesses:

ALBERT H. ADAMS,
EDGAR T. BOND.