



(72) SCHRATTENECKER, Franz, AU

(71) SCHRATTENECKER, Franz, AU

(51) Int.Cl.⁶ A01F 12/40, A01F 29/00

(30) 1998/05/26 (198 23 489.9) DE

(54) **HACHE-PAILLE POUR LA COUPE DU CHAUME**

(54) **STRAW-CUTTING MACHINE FOR THE CHOPPING OF
STALKS**

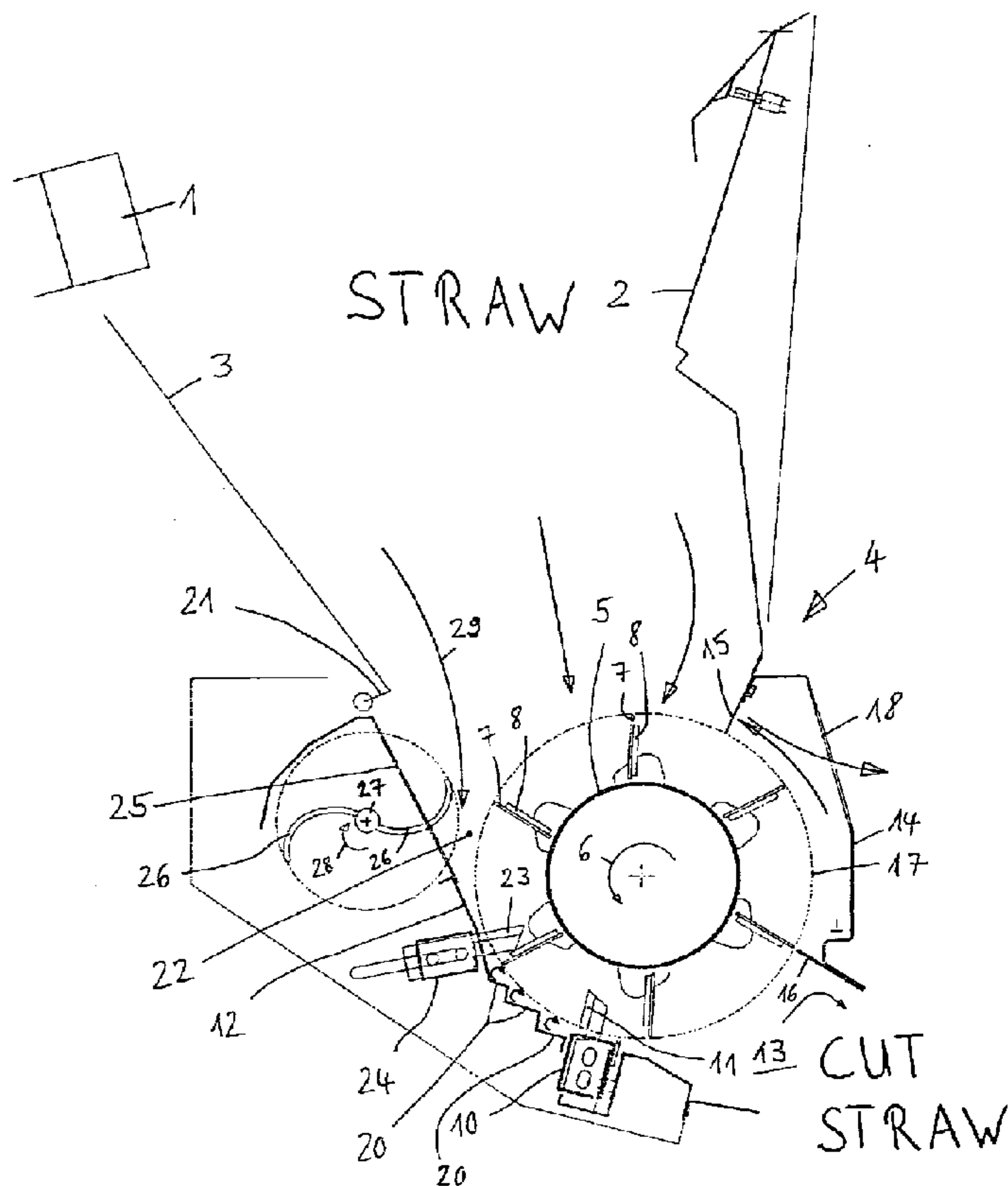

(57) A straw-cutting machine which serves to chop stalks, preferably to chop straw behind the straw-walker end of a combine harvester includes a straw-cutting machine housing in which a rotor provided with cutting tools and a drive is pivoted, a guide plate which forms a straw-cutting machine bottom and an outlet. To improve such a straw-cutting machine, counter-cutters are provided on the straw-cutting machine bottom. Further counter-cutters can be provided in the region of the inlet gap.

1090-69

Abstract

A straw-cutting machine which serves to chop stalks, preferably to chop straw behind the straw-walker end of a combine harvester includes a straw-cutting machine housing in which a rotor provided with cutting tools and a drive is pivoted, a guide plate which forms a straw-cutting machine bottom and an outlet. To improve such a straw-cutting machine, counter-cutters are provided on the straw-cutting machine bottom. Further counter-cutters can be provided in the region of the inlet gap.

1090-69

STRAW-CUTTING MACHINE FOR THE CHOPPING OF STALKS

The invention relates to a straw-cutting machine for the chopping of stalks, preferably for the chopping of straw, behind the straw-walker end of a combine harvester. A straw-cutting machine of this type for the chopping of stalks, preferably for the chopping of straw behind the straw-walker end of a combine harvester having a straw-cutting machine housing generally includes a rotor provided with cutting tools and a drive which is pivoted in the straw-cutting machine housing. The cutting tools can be cutters which can be disposed in a fixed position or hung in a floating or free-swinging manner. Alternatively, rotating catch plates, which can be disposed in a fixed position or hung in a free-swinging manner, can also be used as the cutting tools. The straw-cutting machine housing is generally located behind an inlet funnel whose front wall and rear wall run towards the straw-cutting machine casing and limit the inlet region into the straw-cutting machine housing covered by the rotor. In the region of the rotor, there is furthermore provided a guide plate forming a straw-cutting machine bottom. Furthermore, an outlet is provided through which the cut stalks can leave the straw-cutting machine. Above this outlet, an air outlet hood can be disposed. This can be limited towards the inlet funnel and the outlet at its upper and/or lower edge regions by accumulation plates. The accumulation plates preferably extend very closely, that is, for example, up to around 5 to 10 mm, towards the space in which the cutting tools move.

A straw-cutting machine of this general type is known from DE-OS 195 30 028. In this known straw-cutting machine, the air ring in the form of a mantle enclosing the rotor and rotating with it is

broken by the straw guide plate located under the straw-walker end and forming the rear wall of the inlet funnel. The guide plate is curved in an arc-shape in such a manner that the upper curved end lies below the straw-walkers while the lower end tapers off roughly perpendicularly into the inlet of the straw-cutting machine housing.

This invention seeks to improve a straw-cutting machine of this general type. In accordance with one embodiment of this invention counter-cutters are provided in the straw-cutting machine bottom. The counter-cutters are preferably disposed on a cutter bar. The counter-cutters are preferably located in the outlet region of the straw-cutting machine bottom or of the guide plate, that is in the region of the end of the straw-cutting machine bottom or of the guide plate. The outlet preferably follows on directly from the counter-cutters.

Advantageous embodiments are described in the dependent claims.

Preferably, further counter-cutters are provided in the region of the inlet gap. These counter-cutters are also preferably disposed in a cutter bar. They are preferably located directly behind the inlet gap of the straw-cutting machine. In this embodiment, since counter cutters are provided both in the rear region of the straw-cutting machine bottom and in the front region, the straw-cutting effect is substantially enhanced.

Preferably, the counter-cutters protrude into the cutting area of the cutting tools. To make this possible, the cutting tools are provided with corresponding slits which are penetrated by the counter-cutters. This is described in German patent application

No. 197 49 338.6-23 dated 7 November 1997 to which reference is herewith expressly made.

In another advantageous embodiment, slots are disposed in the straw-cutting machine bottom. This is described in detail in German patent application No. 197 49 337.8-23. These slots are preferably provided over the width of the rotor. They have the effect that the ascending air current generated by the narrowing of the rotor's centrifugal circle and by the counter-cutters is deflected outwards or broken in the inlet region of the straw. In this way, a suction effect is achieved by the rotation of the rotor instead of the ascending air current which impairs the acceptance of the straw. In this way, the acceptance of the straw by the straw-cutting machine is made easier.

Preferably, the slots are penetrated by moving tines. These tines prevent the cut stalks from being able to accumulate in the region of the slots which might impair the slots so that they would lose their venting effect. Instead of the tines, different types of tools can be used which keep the slots free and/or transport the cut stalks.

The tines are preferably disposed on a drivable roller. They move in the direction of movement of the cut stalks, that is in the direction of the straw-cutting machine, by means of which the cut stalks are transported on to the straw-cutting machine.

Embodiments of the invention are described in detail below by means of the enclosed drawing in which:

Fig. 1 shows a first embodiment of a straw-cutting machine with rotating catch plates in a schematic side view;

Fig. 2 shows a second embodiment with cutters hung in a floating manner; and

Fig. 3 shows the embodiment of Fig. 1 in a representation without the arrows indicating the airflow.

Under the end of a straw-walker 1 of a combine harvester, a funnel-shaped inlet housing for the straw is disposed whose front wall and rear wall 3 taper off towards the straw-cutting machine housing 4 and limit the inlet region into the straw-cutting machine housing covered by the rotor 5. Cutting tools 7 are disposed on the casing of the rotor 5, which rotates in the direction of the arrow 6. The cutting tools 7 are designed as catch plates, whose holding plates 8 can be mounted in a fixed position or rotatable around axes on the rotor jacket 5.

In the outlet region of the straw-cutting machine housing, a cutter bar 10 is disposed in a fixed manner on the housing in which the counter-cutters 11 interacting with the catch plates 7 are mounted. The region between the lower end 21 of the rear wall 3 of the funnel-shaped inlet housing and the cutter bar 10 is closed by the straw-cutting machine bottom 12 forming a part of the straw-cutting machine housing 4. The straw-cutting machine bottom 12 forms a guide plate for the cut stalks.

In the region of the inlet slit 22 of the straw-cutting machine, further counter-cutters 23 are provided which are disposed on a second cutter bar 24. Each of the cutters 11 and 23 can be adjusted, that is moved towards the axis of rotation of the rotor 5 or away from it. The counter-cutters 11 and 23 protrude into the cutting area 17 of the cutting tools 7. To make this possible, the cutting tools or catch plates 7 possess a corresponding slot.

The straw-cutting machine bottom 12 possesses in the region between the cutter bars 24 and 10 step-shaped elevations 20 which work as accumulation plates and additionally break and eddy the obstructing ascending air current.

Furthermore, in the straw-cutting machine bottom 12, in the region between the lower end 21 of the rear wall 3 and the cutter bar 24, slots 25 are provided which run in each case in the longitudinal direction and whose plurality essentially extends over the width of the rotor. The slots 25 are penetrated by moving tines 26 which are disposed on a roller (feed roller) 27 drivable in the direction of arrow 28. As can be seen from Fig. 1, those parts of the tines 26 which penetrate the slots 25 move towards the rotor or the counter-cutters 23. They transport the cut stalks in the direction of the arrow 29 into the inlet gap 22 of the straw-cutting machine. In this way, the curved tines 26 of the feed roller 27 prevent cut stalks from being able to accumulate in the region of the inlet gap 22. These cut stalks are further transported from there into the inlet slit of the straw-cutting machine. The tines 26 are curved in the direction of rotation 28 in the manner visible from Fig. 1.

Above the outlet 13 of the straw-cutting machine, a hood 14 is disposed which is provided at its upper end with an accumulation plate 15 and at its lower end with another accumulation plate 16 which are fixed in the manner shown on the circuit 17 covered by the cutting tools 7. The accumulation plates 15 and 16 essentially run perpendicularly to the tangent on the circle swept 17 by the cutters 7; that is, they essentially point towards the axis of rotation of the rotor. The accumulation plates 15 and 16 end a very short distance of around 5 to 10 mm away from the circle 17. The hood 14 is provided on its front

side with one or more perforations or venting slits 18 through which the air can exit and flow out without problem.

In the embodiment of Fig. 2, instead of the catch plates 7, flail cutters 30 are used, and which are hung in a floating manner on axles 31.

1090-69

What is claimed is:

1. A straw-cutting machine for the chopping of stalks behind the straw-walker end of a combine harvester having a straw-cutting machine housing in which a rotor provided with cutting tools and a drive is pivoted, having a guide plate forming a straw-cutting machine bottom and having an outlet, wherein counter-cutters are provided on the straw-cutting machine bottom.
2. A straw-cutting machine according to Claim 1, wherein further counter cutters are provided in the region of the inlet gap.
3. A straw-cutting machine according to Claims 1 or 2, wherein the counter-cutters protrude into the circle swept by the cutting tools.
4. A straw-cutting machine according Claim 1, 2 or 3, wherein slots are disposed in the straw-cutting machine bottom.
5. A straw-cutting machine according to claim 4, wherein the slots are penetrated by moving tines.
6. A straw-cutting machine according to Claim 5, wherein the tines are disposed on a drivable roller.

Fig. 1

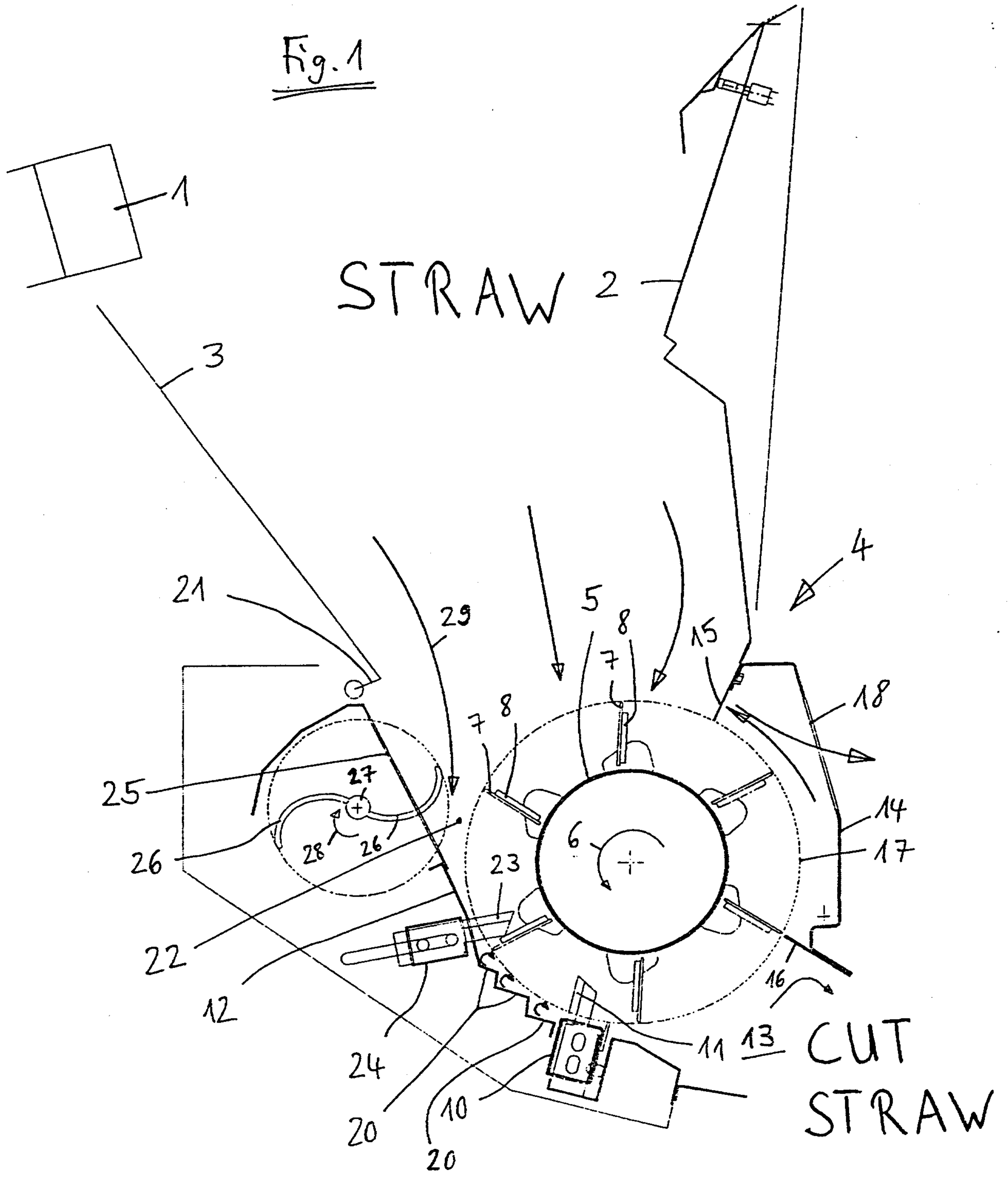

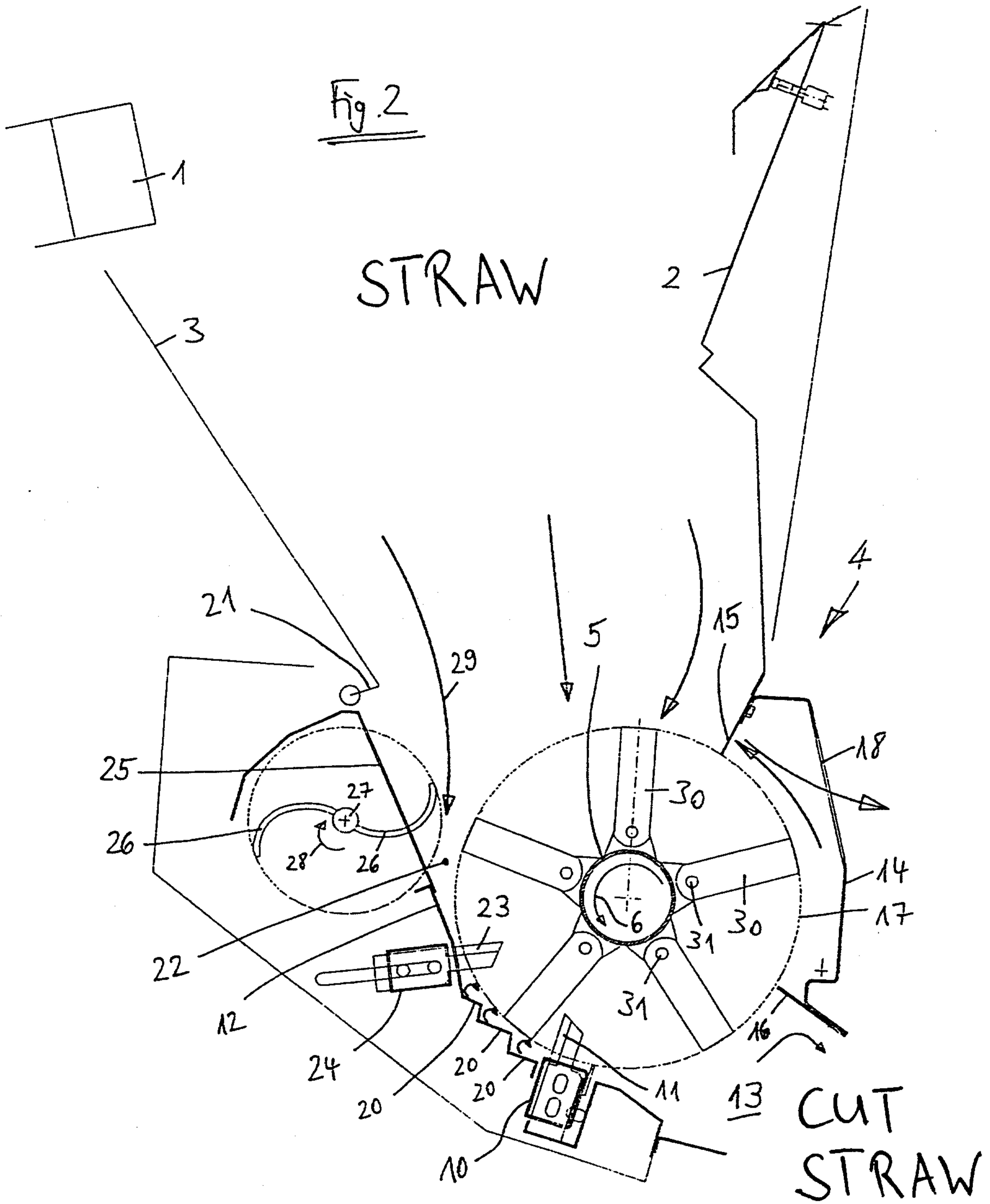

Fig. 3

