



US007841868B2

(12) **United States Patent**
Tang et al.

(10) **Patent No.:** **US 7,841,868 B2**
(45) **Date of Patent:** **Nov. 30, 2010**

(54) **SOCKET CONNECTOR HAVING POSITIONING MEMBERS FOR ORIENTATING COVER AND BASE THEREOF**

(75) Inventors: **Kun Tang**, Shenzhen (CN); **Jie-Feng Zhang**, Shenzhen (CN); **Wen He**, Shenzhen (CN)

(73) Assignee: **Hon Hai Precision Ind. Co., Ltd.**, Taipei Hsien (TW)

(*) Notice: Subject to any disclaimer, the term of this patent is extended or adjusted under 35 U.S.C. 154(b) by 0 days.

(21) Appl. No.: **12/535,852**

(22) Filed: **Aug. 5, 2009**

(65) **Prior Publication Data**

US 2010/0035455 A1 Feb. 11, 2010

(51) **Int. Cl.**
H01R 12/00 (2006.01)

(52) **U.S. Cl.** **439/71; 439/342**

(58) **Field of Classification Search** None
See application file for complete search history.

(56) **References Cited**

U.S. PATENT DOCUMENTS

3,771,109 A * 11/1973 Bruckner et al. 439/331

4,166,665 A *	9/1979	Cutchaw	439/196
5,092,789 A *	3/1992	Sinclair	439/259
6,338,639 B1 *	1/2002	Trout et al.	439/342
6,425,768 B1 *	7/2002	Taylor	439/67
6,450,824 B1 *	9/2002	Lemke et al.	439/342
6,514,097 B1 *	2/2003	Conroy	439/330
6,679,717 B2	1/2004	Zhang et al.	
7,244,136 B2 *	7/2007	Hao	439/342
7,318,736 B1 *	1/2008	Ambady	439/259
7,362,581 B2 *	4/2008	Chen	361/709
7,591,663 B2 *	9/2009	Lu	439/342
2004/0005800 A1 *	1/2004	Hou	439/342
2009/0061673 A1 *	3/2009	Zhang et al.	439/342

* cited by examiner

Primary Examiner—Michael C Zarroli

(74) *Attorney, Agent, or Firm*—Andrew C. Cheng; Wei Te Chung; Ming Chieh Chang

(57) **ABSTRACT**

A socket connector (1) for electrically connecting a Central Processing Unit (CPU) with a Printed Circuit Board (PCB), includes a base (10), a cover (20) and a shaft (30) attached to the cover and pivotally driving the cover to move on the base. The base has a plurality of conductive contacts received therein and defines a plurality of apertures (104) in the middle thereof. The cover forms a plurality of pillars (208) extending through the apertures and forward a lower surface of the base. The pillars are moveable in the apertures along with the cover.

8 Claims, 6 Drawing Sheets

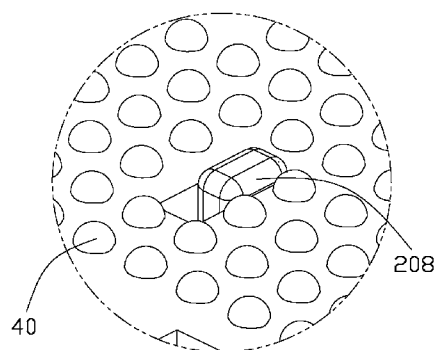
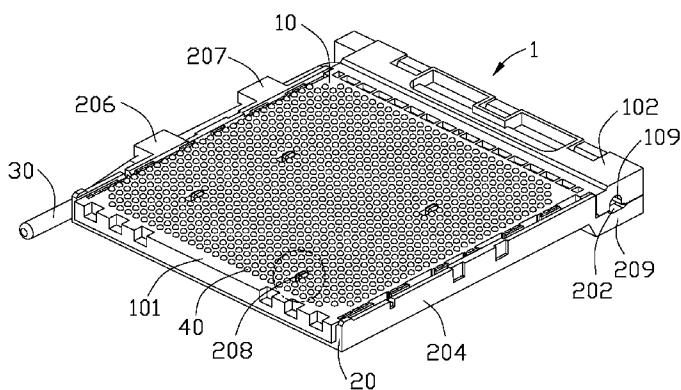

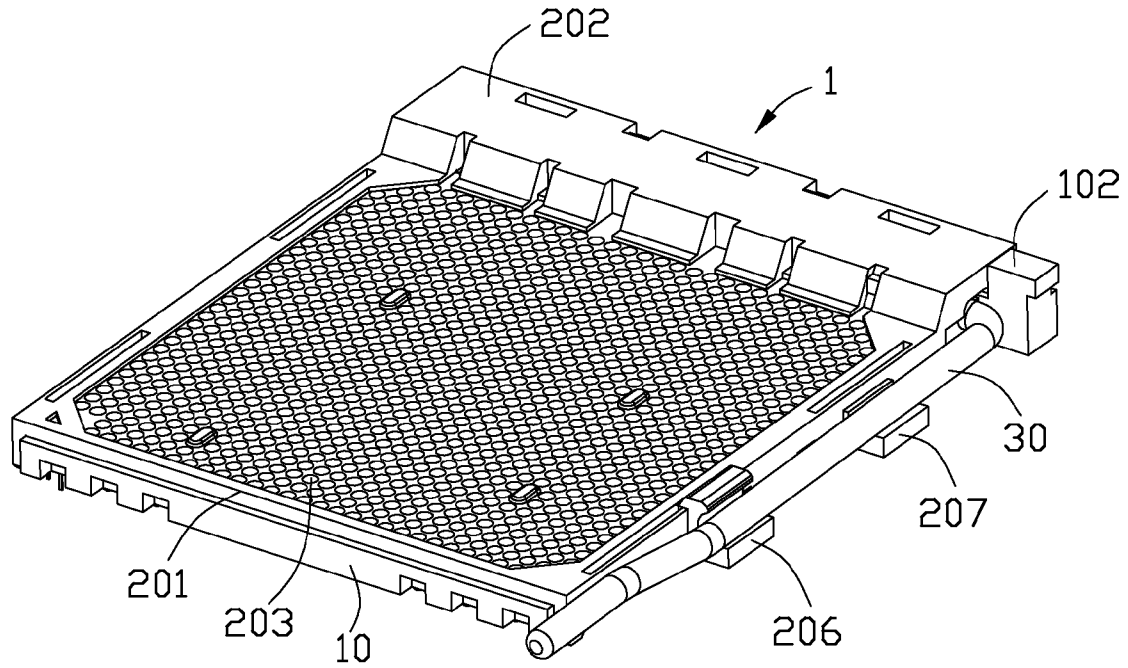

FIG. 1

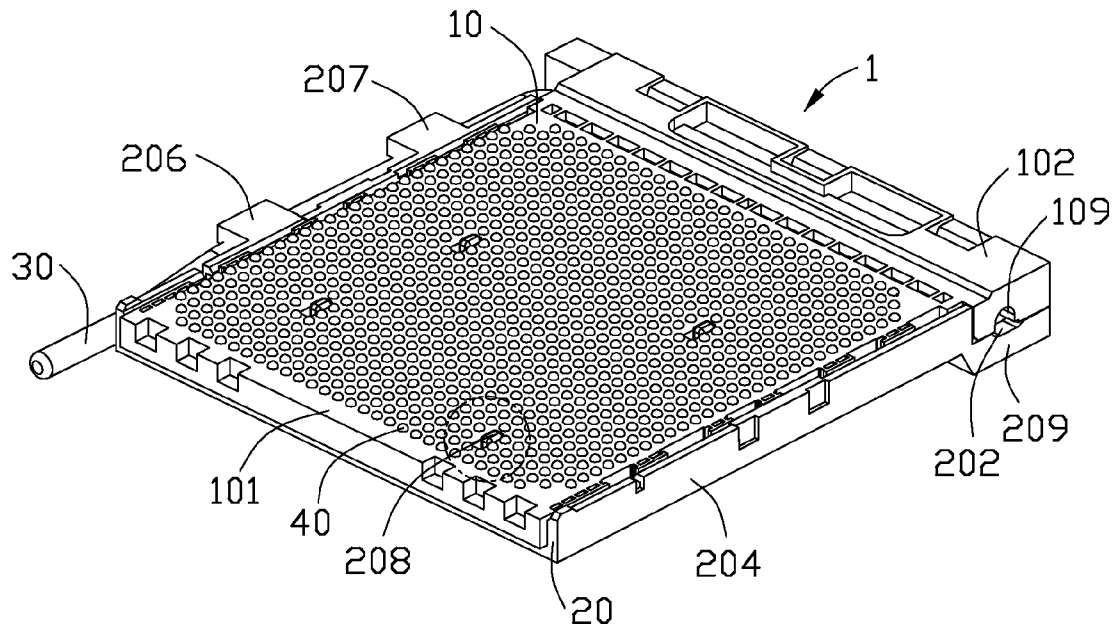

FIG. 2

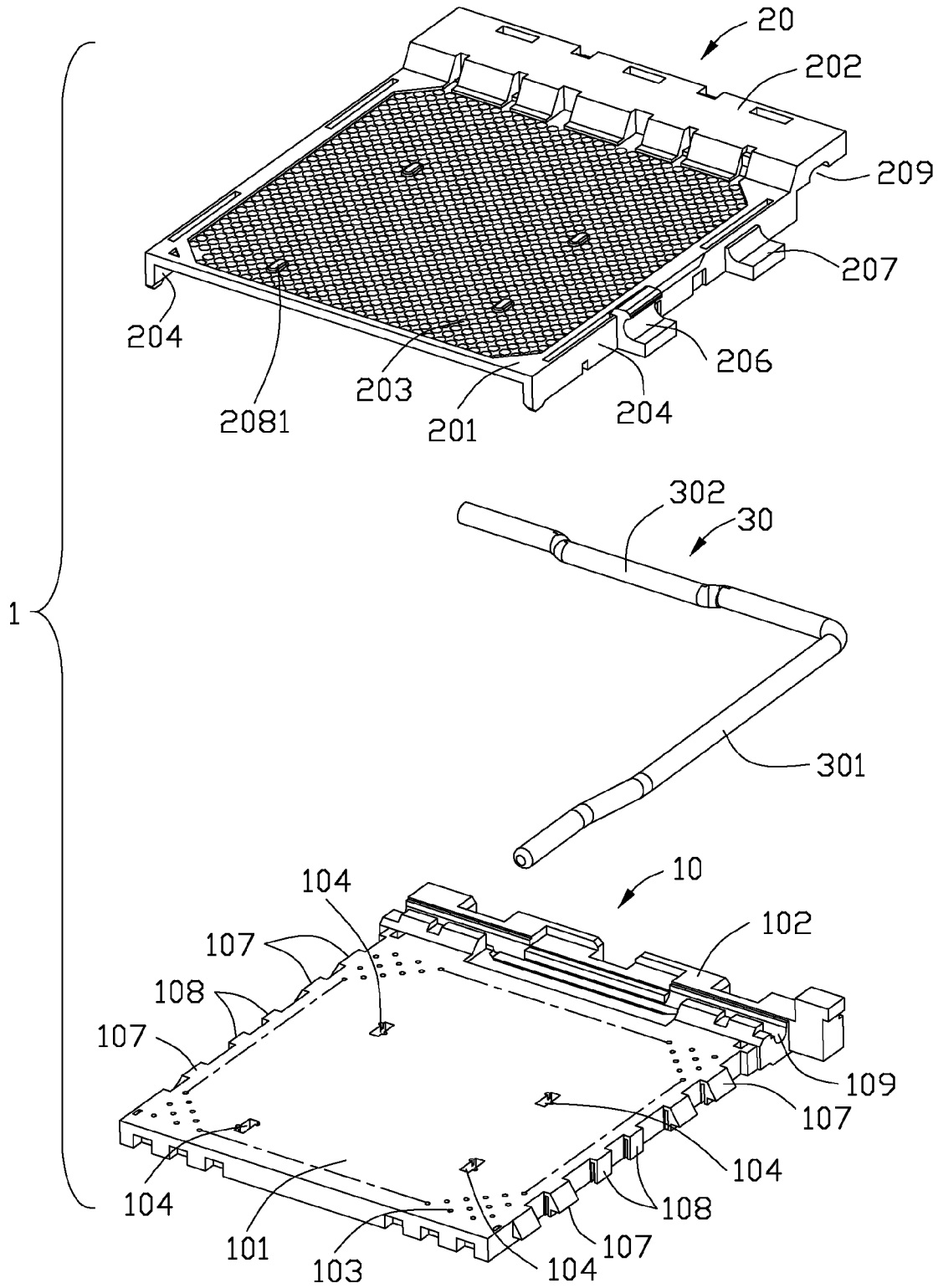

FIG. 3

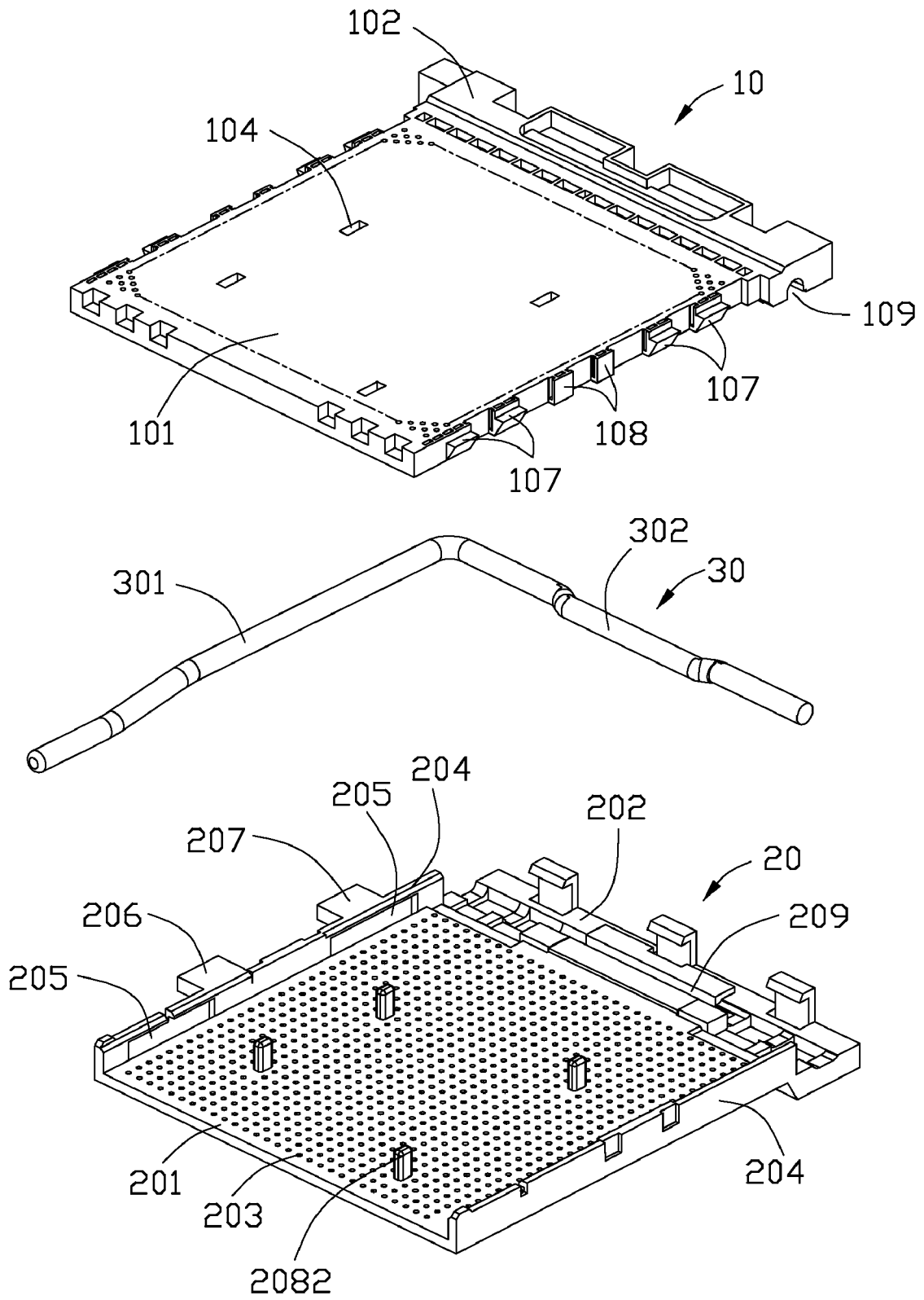

FIG. 4

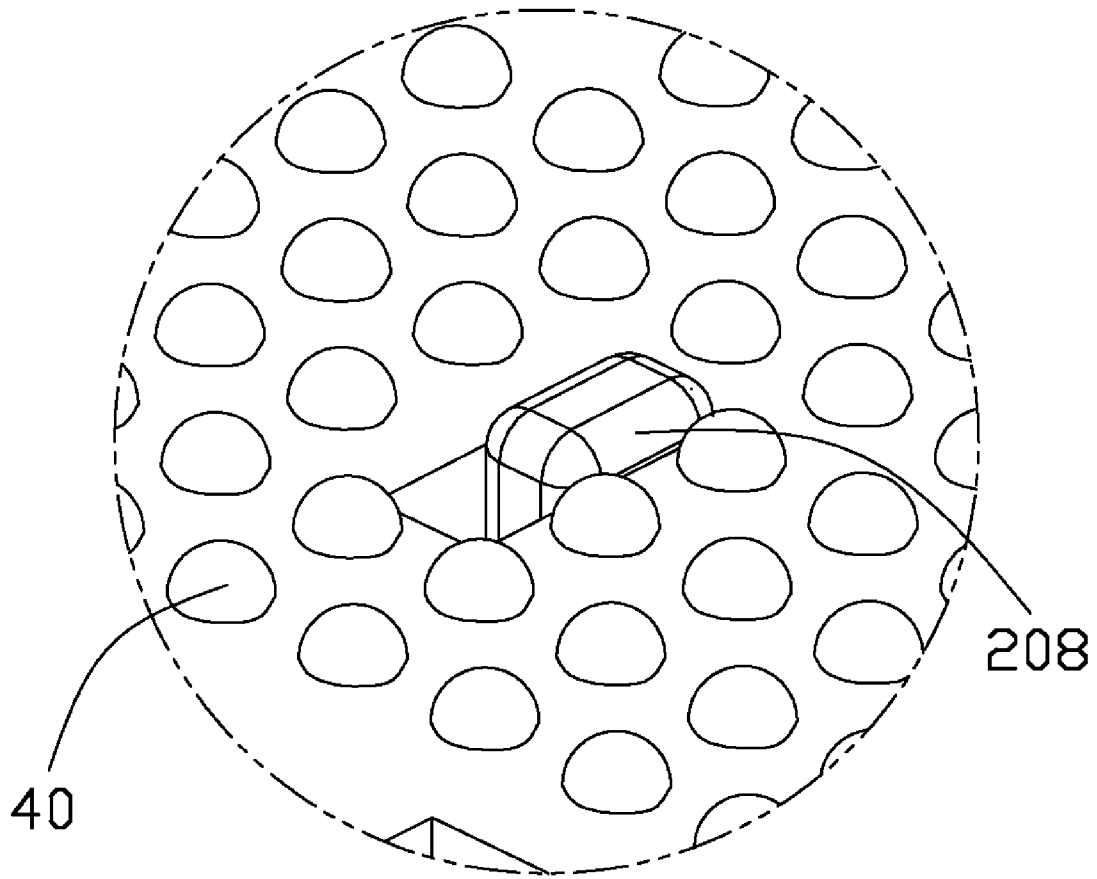

FIG. 5

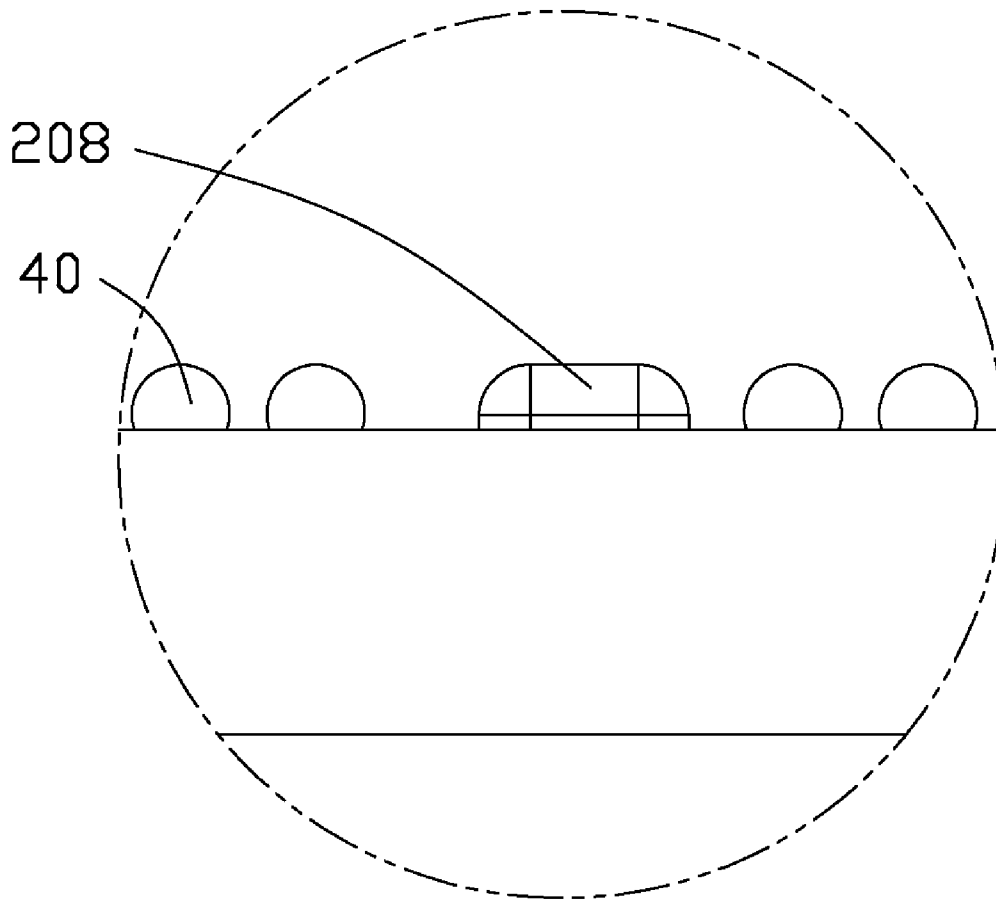

FIG. 6

1

SOCKET CONNECTOR HAVING POSITIONING MEMBERS FOR ORIENTATING COVER AND BASE THEREOF

BACKGROUND OF THE INVENTION

1. Field of the Invention

The present invention relates generally to a socket connector, and more particularly to a socket connector having positioning members for orientating cover and base thereof.

2. Description of Related Arts

As known publicly, a Central Processing Unit (CPU) functions as a heart of the computer, which deals with and operates pluralities of data in the computer. Such a CPU is usually connected with a printed circuit board (PCB) by a socket connector, which is soldered with the PCB and receives the CPU. The socket connector comprises a plurality of conductive contacts soldering with the electrical pads of the PCB while the CPU comprises a plurality of electrical pins corresponding to the conductive contacts of the socket connector so as to contact with the conductive contacts for data communication. According to varieties of packing forms of the CPUs, the socket connectors form different structures for receiving different CPUs. With a development of the semiconductor technology, a sort of socket connector with zero insertion force appears. Such kind of socket connector comprises a base in a lower level, a cover shielding over the base in an upper level and a shaft pivoting for driving the cover to move on the base. The base defines a plurality of passageways for receiving the conductive contacts. The passageways are usually arranged in a matrix. The cover defines a plurality of slots, each slot corresponding to one conductive contact. When the socket connector is not in use, the slot is superpositioned on the corresponding passageway, i.e. the slot is located above each conductive contact. The conductive contact comprises a base portion, a pair of wing portions extending from two lateral sides of the base portion to define a first larger receiving room therebetween and a pair of contact portions at the distal ends of the wing portions for defining a second smaller receiving room therebetween. When the CPU are laid on an upper surface of the cover, each pin of the CPU is conveniently inserted through the slot of the cover into the first larger receiving room, an electrical connection is not achieved; and then, the cover moves on the base by pivoting the shaft to drive the pin of the CPU to move from the first larger receiving room towards the second smaller receiving room that at last, the pin is compressed by the contact portions of the conductive contact. An electrical connection between the CPU and the conductive contact is achieved.

However, such kind of socket connector with zero insertion force is usually soldered to the PCB in an Infra-Red soldering process. In the Infra-Red soldering process, the base and the cover of the socket connector are probably warped under so high temperature. Moreover, the cover is attached to the base only by two frames of the cover on two lateral sides thereof interfering with a plurality of protrusions formed on two lateral sides of the base. Therefore, the cover is positioned to the base loosely. The aforementioned mentions may cause damage to the electrical connection between the CPU and the conductive contacts.

2

Hence, an improved socket connector having positioning members for orientating cover and base thereof and thereby achieving a good electrical connection between the contacts and the CPU is desired.

5

SUMMARY OF THE INVENTION

Accordingly, an object of the present invention is to provide a socket connector having positioning members for orientating cover and base thereof and thereby achieving a good electrical connection between the contacts and the CPU.

To achieve the above object, an electrical connector for electrically connecting a Central Processing Unit (CPU) with a Printed Circuit Board (PCB), includes a base, a cover and a shaft attached to the cover and pivotally driving the cover to move on the base. The base has a plurality of conductive contacts received therein and defines a plurality of apertures in the middle thereof. The cover forms a plurality of pillars extending through the apertures and forward a lower surface of the base. The pillars are moveable in the apertures along with the cover.

Other objects, advantages and novel features of the invention will become more apparent from the following detailed description when taken in conjunction with the accompanying drawings.

BRIEF DESCRIPTION OF THE DRAWING

FIG. 1 is a perspective, assembled view of a socket connector according to the present invention;

FIG. 2 is another perspective, assembled view of FIG. 1;

FIG. 3 is a perspective, disassembled view of the socket connector without the conductive contacts and the solder balls soldered with the conductive contacts; and

FIG. 4 is another perspective, disassembled view of FIG. 3.

FIG. 5 is a partly amplified view of the socket connector of FIG. 2.

FIG. 6 is a side view of FIG. 5.

DETAILED DESCRIPTION OF THE PREFERRED EMBODIMENT

FIGS. 1-4 illustrate a socket connector **1** in accordance with the present invention, used for connecting a Central Processing Unit (CPU) (not shown) with a printed circuit board (PCB) (not shown) to transmit signals therebetween. The socket connector **1** comprises a base **10** in a lower level, a cover **20** shielding over the base **10** in an upper level, a plurality of conductive contacts (not shown) received in the base **10** and a shaft **30** laterally attaching to the base **10** and the cover **20** and pivoting for driving the cover **20** to move on the base **10**. The socket connector **1** is soldered on the PCB by solder balls **40** which are located below the base **10** and electrically connected with the conductive contacts.

Referring to FIGS. 3 and 4, the base **10** has a rectangle shape, comprising a retaining portion **101** and a receiving portion **102** at a rear side of the retaining portion **101** taking along a front-to-rear direction. The retaining portion **101** defines a plurality of passageways **103** for retaining the conductive contacts therein. The retaining portion **101** defines four apertures **104** in a middle part thereof. The four apertures **104** are arranged at four vertexes of a quadrangle with a smaller size than the base **10**. The central point of the base **10** prefers to be situated in the quadrangle defined by the apertures **104**. The number of the apertures **104** is not limiting in four, other numbers are also feasible, anyway, the apertures **104** are arranged at vertexes of a polygon and the central point

of the base **10** prefers to be situated in the polygon defined by the apertures **104**. The base **10** forms at least two lugs **107** outwardly at the lateral sides thereof and a pair of protrusions **108** located between the two lugs **107**. The receiving portion **102** is a long-narrow one which extends along a left-and-right direction. The receiving portion **102** defines a first recess **109** from the left to the right for partly receiving the shaft **30**. A transverse section of the first recess **109** is a semicircle.

As is indicated in FIGS. **3** and **4**, the cover **20** has a rectangle shape too, defining a top face confronting the CPU and a bottom face confronting the base. The cover **20** comprises a base portion **201** and a head portion **202** at a rear side of the base portion **201**. The base portion **201** and the head portion **202** are arranged in different levels, while the head portion **202** is located above the base portion **201**. The base portion **201** defines a plurality of slots **203**, each corresponding to one passageway **103** of the base **10**. The base portion **201** forms four pillars **208** integrally extending therefrom. Each pillar **208** has a short upward protrusion **2081** unitarily extending from an upper face of the cover **20** and a long downward protrusion **2082** unitarily extending from a lower face of the cover **20** in vertical alignment with the short upward protrusion **2081**. A pair of lateral walls **204** also extends downwardly from the opposite edges of the base portion **201**. Each lateral wall **204** defines two recessed portions **205** at inner surfaces thereof. The recessed portions **205** of one lateral wall **204** face towards the ones of the other lateral wall **204**. One lateral wall **204** forms a locking portion **206** at a front part thereof and extending outwardly therefrom. The lateral wall **204** further comprises a supporting portion **207** at a rear part thereof for releasing friction force to the shaft **30**. The head portion **202** is also a long-narrow one which extends along the left-and-right direction as the receiving portion **102**. The head portion **202** defines a second recess **209** from the left to the right for partly receiving the shaft **30**. A transverse section of the second recess **209** is also a semicircle. The first and second recesses **109**, **209** are combined to be a column receiving space.

Referring to FIGS. **3** and **4**, the shaft **30** comprises a driving portion **301** extending along the front-to-rear direction and an active portion **302** extending along the left-and-right direction. The driving portion **301** is locked with the locking portion **206** of the cover **20** and is supported by the supporting portion **207**. The active portion **302** is received in the column receiving space defined by the first and second recesses **109**, **209**. A user can push the shaft **30** and then drives the cover **20** to move on the base **10**. The lugs **107** of the base **10** are received in the recessed portions **205** of the cover **20** and move in the recessed portions **205** when the cover **20** moves on the base **10**. The lugs **107** provide orientation force between the cover **20** and the base **10**. The long downward protrusions **2082** of the pillars **208** of the cover **20** are received in the apertures **104** of the base **10** and move in the apertures **104** when the cover **20** moves on the base **10**. The pillars **208** provide more orientation force between the cover **20** and the base **10** so as to achieve good electrical connection between the CPU and the conductive contacts though under high temperature in the Infra-Red soldering process. The solder balls are located in a first plane, and the pillar **208** extends outside of the base **10** to the first plane to perform as a standoff.

While a preferred embodiment in accordance with the present invention has been shown and described, equivalent modifications and changes known to persons skilled in the art according to the spirit of the present invention are considered within the scope of the present invention as described in the appended claims.

What is claimed is:

1. A socket connector for electrically connecting a Central Processing Unit (CPU) with a Printed Circuit Board (PCB), comprising:

a base with a plurality of conductive contacts received therein defining a plurality of apertures in the middle thereof, the base comprising at least two lugs at lateral sides thereof and a receiving portion at a rear part thereof, the receiving portion defining a first recess;

a cover forming a plurality of pillars extending through the apertures and toward a lower surface of the base, the cover comprising a pair of lateral walls defining a plurality of recessed portions at inner surfaces thereof such that the lugs are moveably received in the recessed portions, the cover comprising a head portion corresponding to the receiving portion, the head portion defining a second recess, both transverse sections of the recesses semicircle-shaped and the recesses combining a column receiving space, the cover forming a locking portion at a lateral side thereof; and

a shaft pivotally driving the cover to move on the base along a front-to-back direction, the shaft comprising an active portion received in the column receiving space and a driving portion capable of being locked with the locking portion of the cover;

wherein the pillars are moveable in the apertures along with the cover in the front-to-back direction, both the rear part and the head portion extend along a transverse direction relative to the front-to-back direction.

2. The socket connector as described in claim **1**, wherein the cover further forms a supporting portion at the same lateral wall as the locking portion to support the shaft.

3. An electrical connector for electrically connecting a Central Processing Unit (CPU) to a main board, comprising:

a first housing defining a plurality of first passageways and at least one aperture defined among the passageways;

a second housing attached to the first housing and moveable along a front-to-back direction with respect to the first housing, the second housing defining a plurality of second passageways therethrough;

at least one protrusion extending from the second housing towards the first housing and moveably received in the at least one aperture of the first housing along the front-to-back direction; and

a plurality of contacts disposed in one of the first housing and the second housing, each contact having a solder ball attached thereto which is located in a first plane; wherein

the at least one protrusion has a distal end extending outside of the first housing to the first plane to perform as a standoff.

4. The electrical connector as described in claim **3**, wherein the second housing defines a top face confronting the CPU and a bottom face confronting the first housing.

5. The electrical connector as described in claim **3**, further comprising a shaft attached to the first housing and the second housing and pivotally driving one of the housings to move with respect to the other.

6. An electrical connector comprising:

an insulative base defining a plurality of passageways extending therethrough in a vertical direction;

a plurality of contacts disposed in the corresponding passageways, respectively;

an insulative cover with lateral walls defining an area with a plurality of through holes in vertical alignment with the

5

corresponding passageways, respectively, said cover being moveable relative to the base along a front-to-back direction;
a plurality of pillars mounted within the area of the cover through holes and not as part of the cover lateral walls, each pillar has a short upward protrusion unitarily extending from an upper face of the cover and;
each pillar also has a long downward protrusion unitarily extending from a lower face of the cover in vertical alignment with the corresponding short upward protrusions, respectively.

6

7. The electrical connector as claimed in claim 6, wherein said base is further equipped with a plurality of passages extending therethrough in said vertical direction under condition that said passages are larger than the passageways and receive said downward protrusions therein.

8. The electrical connector as claimed in claim 6, wherein said base is further equipped with a plurality of passages and the long downward protrusions extend outside of the base throughout the passages, respectively.

* * * * *