

C. F. WEICHOLD.
 STAIR RAIL PROJECTING DEVICE.
 APPLICATION FILED MAR. 27, 1908.

908,526.

Patented Jan. 5, 1909.

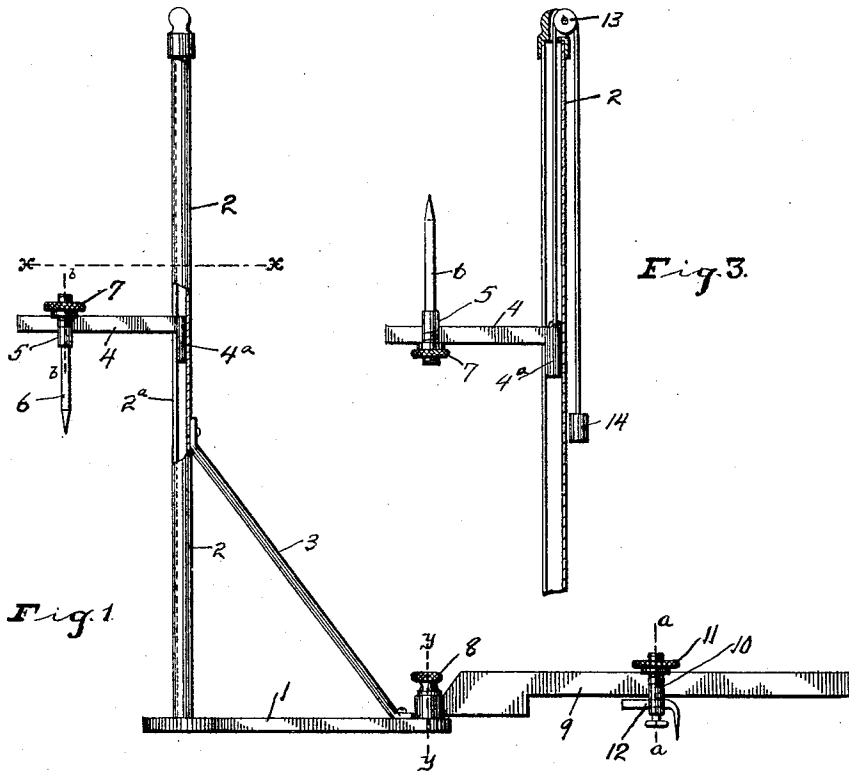

Fig. 1

Fig. 3

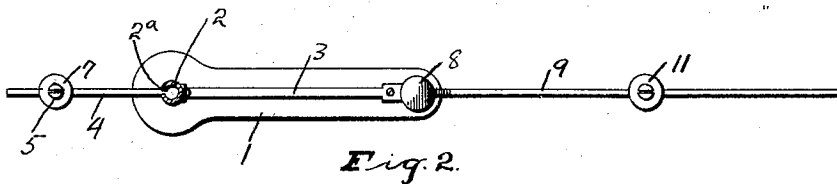

Fig. 2.



Fig. 4.

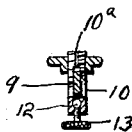

Fig. 5.

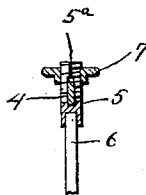

Fig. 6.

Inventor

Charles F. Weichold

Witnesses
 Carl Stoughton
 A. L. Phelps

By

C. C. Shepherd
 Attorney

UNITED STATES PATENT OFFICE.

CHARLES F. WEICHOLD, OF COLUMBUS, OHIO.

STAIR-RAIL-PROJECTING DEVICE.

No. 908,526.

Specification of Letters Patent.

Patented Jan. 5, 1909.

Application filed March 27, 1908. Serial No. 423,635.

To all whom it may concern:

Be it known that I, CHARLES F. WEICHOLD, a citizen of the United States, residing at Columbus, in the county of Franklin and State of Ohio, have invented certain new and useful Improvements in Stair-Rail-Projecting Devices, of which the following is a specification.

My invention relates to the improvement of stair rail projecting devices and the objects of my invention are to provide a simple and inexpensive mechanism whereby the lines on which a piece of material from which a stair rail is to be cut, may be readily indicated, such lines accurately indicating the curvature and inclination of the rail; to so construct my improved device as to project from a plan drawing, lines on a piece of material from which a stair rail is to be cut which will indicate the bevel to be imparted thereto; to adapt my improved device for indicating the curvature and incline of a stair-way face mold and to provide for the accurate marking of the stair-rail joint or spring line and to produce other improvements the details of which will be more fully pointed out hereinafter. These objects I accomplish in the manner illustrated in the accompanying drawing, in which:

Figure 1 is a side elevation of my improved device showing a portion of a vertical standard which I employ, cut away for the sake of clearness in illustration, Fig. 2 is a transverse section on line $x-x$ of Fig. 1, Fig. 3 is a central vertical section of a portion of the standard illustrating a means of counterbalancing the pencil holding arm, Fig. 4 is a transverse section on line $y-y$ of Fig. 1, Fig. 5 is a similar section on line $a-a$ of Fig. 1, and, Fig. 6 is a similar section on line $b-b$ of Fig. 1.

Similar numerals refer to similar parts throughout the several views.

In carrying out my invention, I employ a horizontal elongated base 1 adapted to be supported upon a floor, table or other horizontal support. From the outer or forward end of this base piece rises a vertical tube 2, said tube being provided on its forward side with a longitudinally slotted opening 2^a. This tube is preferably assured in its vertical position by a brace 3 which extends from the tube to the upper side of the rear portion of the base 1. Within the tube 2 is contained the vertical plunger-like ex-

tension 4^a of a horizontal arm 4 which extends loosely through the slotted opening 2^a of the tube.

5 represents a pencil holder which is in the nature of a short vertical socket piece, the lower end of which receives and holds the upper end of a pencil 6. The upper portion of the member 5 has formed there-through an opening through which passes the horizontal arm 4. The upper end portion of the member 5 is externally threaded and is split centrally as indicated at 5^a. The threaded portion of the member 5 carries a suitable form of clamping nut 7 which tends to draw the separated portions of the member 5 together and at the same time is adapted by being screwed downward into contact with the arm 4, to hold said member 5 in rigid connection therewith. With the rear end of the base 1 is connected through the medium of a suitable form of screw 8, one end of an arm 9, the underside of which is recessed throughout the greater portion of its length to raise the same above the supporting level of the base 1. This arm or bar 9 passes through a slotted opening in a vertical externally threaded member 10, the upper portion of which is preferably split vertically as indicated at 10^a in Fig. 5. Above the arm the threaded member 10 carries a clamping nut 11 and below the arm, said member has passing therethrough in the direction of the length of the arm, the upper horizontal member of an angular centering finger 12, which is adjustably held in engagement with the member 10 by a set screw 13. As indicated in Fig. 1 of the drawing, the vertical and depending member of the finger 12 is preferably pointed.

Assuming that it is desired to indicate on a board or piece of material from which a stair rail is to be cut, the lines which must be followed in sawing the material for the production of a rail of proper inclination and curvature, the manner of utilizing my device is as follows:

The pitch or inclination of the stair-way having first been ascertained, the board or piece of material from which the rail is to be cut, is placed beneath the arm 4 and its pencil 6, on an incline corresponding with that of the stairway and the arm or bar 9 is made to project over a horizontally supported plan drawing of the stair-rail to be produced. The parts being in this position, the downturned point of the centering finger

is made to engage a point on the drawing which is the center from which the curve of the stair rail drawing was produced. The device comprising the base 1, arm 9, arm 5 4 and its pencil 6, is now swung on the pivot formed by the point of the end of the finger 12, causing the pencil point to produce upon the inclined board a curved line in the arc of a circle, the center of which is the point 10 of the finger 12. By thus engaging the centering finger with the various centers of the curves employed in the drawing to illustrate the curvature and elevation of the stair rail, it is obvious that the upper side 15 of the board will have accurately marked thereon by the point of the pencil 6, the upper line of the saw cut which is to be made therein in producing the rail. In order to mark the underside of the board 20 either in a line immediately below the line previously marked upon the upper surface thereon, or at one side of said upper surface line so as to indicate both the upper and lower bevel lines on the board, it is obvious 25 that the pencil holding member 5 may be removed from the arm 4 unthreaded and again secured on said arm, in which position the pencil will be adapted to mark the underside of the board. It will also be understood that substantially the same operation 30 will be employed in the production of the lines indicating the face mold adjoining a stair rail. It has also been found that by using the arm or bar 4 as a straight edge 35 the proper rail joint or "spring" line may be indicated on the board with a pencil in the hand of the operator.

In Fig. 3 of the drawing, I have shown the pencil holder and pencil in the inverted 40 position for marking the underside of the board and I have also shown in said figure a slight modification in construction which consists in connecting one end of a cord with 45 the inner end of the arm 4, running said cord upward through the tubular standard

2 and over a journaled pulley 13 in the upper portion of the tube thence downward to a suitable weight 14 which is adapted to counterbalance the weight of the arm 4. By the use of this latter construction, it 50 will be understood that the pencil point may be elevated to the desired height and retained in such position by the counterbalance 14.

It has been customary in laying out the 55 lines upon a board or other piece of material which are to be followed in producing a stair rail, to work out the degrees of curvature and inclination by geometry or by other printed and more or less complicated 60 rules. The device herein shown and described, however, although simple in construction and adapted to be manufactured at a comparatively low cost, may be readily employed in the manner indicated above, 65 to accurately mark the materials from which the stair rail or face mold is to be cut.

What I claim, is:

1. In a stair rail projecting device, the combination with a horizontal base member 70 and a centering finger carried thereby, of a standard rising from said base, a vertically movable arm extending horizontally from said standard, and means connected with said arm for supporting a pencil at right 75 angles therewith.

2. In a stair rail projecting device, the combination with a base and a centering finger adjustably supported from said base, of a vertical standard rising from the base, 80 an arm extending horizontally from and vertically adjustable in said standard, and a pencil holding device adapted to be adjusted horizontally on said arm.

In testimony whereof I affix my signature 85 in presence of two witnesses.

CHARLES F. WEICHOLD.

Witnesses:

A. L. PHELPS,

L. CARL STOUGHTON.