

(No Model.)

G. D. BURTON & E. E. ANGELL.
FLEXIBLE ELECTRODE.

No. 475,191.

Patented May 17, 1892.

FIG. 1.

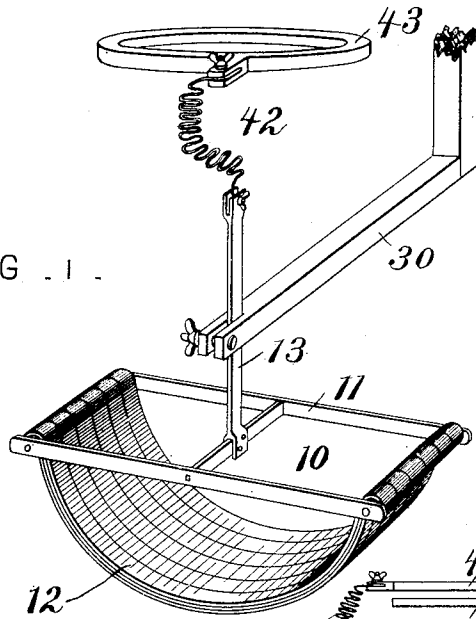

FIG. 2.

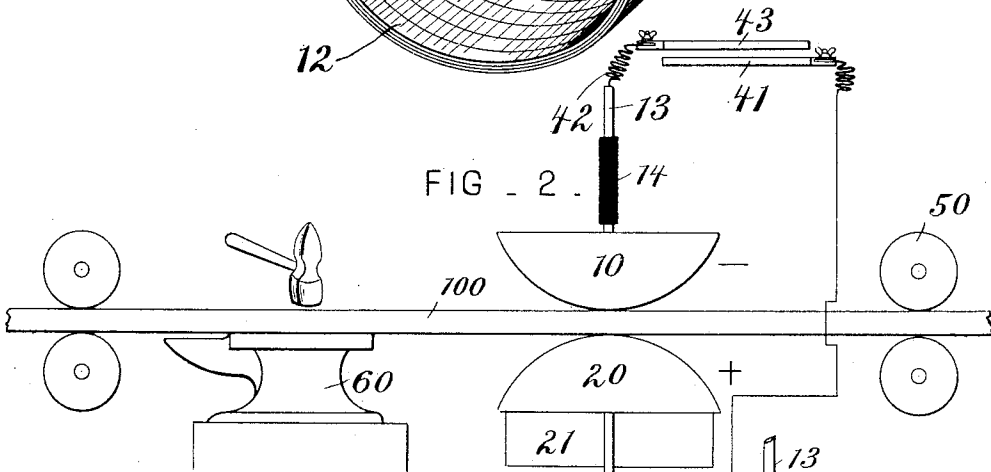

FIG. 3.

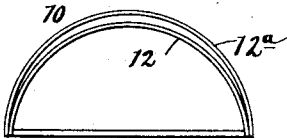
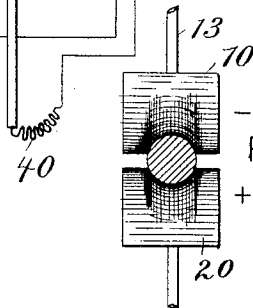

FIG. 5.



FIG. 4.



Attest:
Geo. T. Smallwood,
Chas. H. Reed

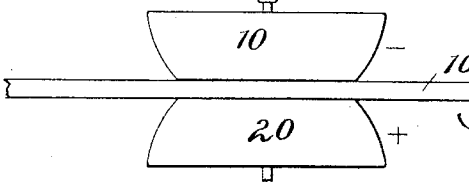

Inventors
G. D. Burton
E. E. Angell,
By J. B. Jones
Attorney.

UNITED STATES PATENT OFFICE.

GEORGE D. BURTON, OF BOSTON, AND EDWIN E. ANGELL, OF SOMERVILLE,
MASSACHUSETTS, ASSIGNORS TO THE ELECTRICAL FORGING COMPANY,
OF MAINE.

FLEXIBLE ELECTRODE.

SPECIFICATION forming part of Letters Patent No. 475,191, dated May 17, 1892.

Application filed June 26, 1891. Serial No. 397,645. (No model.)

To all whom it may concern:

Be it known that we, GEORGE D. BURTON, residing at Boston, in the county of Suffolk, and EDWIN E. ANGELL, residing at Somerville, in the county of Middlesex, State of Massachusetts, citizens of the United States, have invented certain new and useful Improvements in Flexible Electrodes for Electric Heaters, of which the following is a specification.

This invention relates to flexible electrodes for electric heaters for heating bars or blanks of metal or metal tools to be forged or tempered.

The object of this invention is to provide an electrode for this purpose which will yield to the irregularities of the article to be heated and conform somewhat to the shape thereof, so as to enlarge or diminish, as desired, the contact-surface, and secure a good contact between the electrode and the blank.

Another object of the invention is to provide an electrode, which is free to be moved in any direction by the operator, so that it may be placed in contact with any part of the article to be heated.

In the drawings, Figure 1 represents a perspective view of this improved flexible electrode, connected with one of the rings of an electric-current converter. Fig. 2 represents in diagram an electric forge, provided with these improved electrodes in connection with the rings of an electric converter, a forge, feed-rolls, and a bar of metal to be heated and forged. Fig. 3 represents a side elevation of an electric forge consisting of two of these flexible electrodes, having flat contact-plates in contact with the bar to be heated. Fig. 4 represents an end view of these improved electrodes in contact with a round bar to be heated. Fig. 5 is a modification of the electrode, as hereinafter described.

Similar numerals of reference indicate corresponding parts in the different figures.

This improved electrode 10 comprises a frame 11 and a series of flexible bowed contact-plates 12, connected at their opposite ends to the end cross-bars of said frame. These plates may be flat, concave, or convex longitudinally. The frame is composed of cop-

per, or other suitable highly conductive material, and the plates may be composed of copper or of steel, or of other suitable flexible conductive material. The frame and the bowed plates are preferably so proportioned as to be equal in conductivity. The frame 11 is provided with an arm 13, connected to the central cross-bar of said frame. This frame may be provided with an insulated handle 14, as shown in Fig. 3.

Two of these flexible electrodes disposed one above the other constitute an electrical heater or forge, as illustrated in Fig. 2. The lower electrode rests upon a suitable movable support 21, and the upper electrode may be pressed against the bar to be heated by the hand of the operator upon the insulated handle 14, or this electrode may be clamped in the forked outer end of a fixed arm 30, and thereby held in contact with the bar or blank. The lower electrode 20 is preferably similar in general construction and arrangement to the upper electrode, although it may be rigid and of any suitable construction, and it is connected by a wire or other flexible conductor 40 with the positive ring 41 of an electric converter or other source of a heating-current, and the upper electrode is connected by a similar flexible conductor 42 with a negative ring 43 of said converter. These conductors are to be made of large size or of metal of great conductivity in proportion to the bars to be worked.

A pair of feed-rolls 50 may be disposed on one side of the electric forge and an anvil 60 or a forging-machine may be disposed in proximity to said forge on the other side thereof.

In the use of this improved electrode it is pressed into contact with the bar or blank 100 or other article to be heated, and the area of contact is increased or diminished according to the degree of pressure applied, and the contact-surface adjusts itself to the shape or irregularities of the article to be heated, the series of plates imparting flexibility while affording ample capacity for the passage of the current without overheating the electrode. The current passes from one electrode to the other through the bar or blank and thereby heats it.

By the use of this apparatus we are enabled to produce a greater or less degree of heat in the bar 100 in a given time, because as the contact-surface of the electrodes is increased by pressure moving them against the bar the resistance is diminished and the heating of the bar will be slower. Also, if one electrode be pressed against the bar while the other remains stationary the heating on that side of the bar will be reduced in proportion to that on the side of the stationary electrode. It is evident that this will afford great convenience in altering or regulating the heat in different portions of the bar preparatory to forging or shaping it. For illustration, suppose a rectangular bar were intended to be forged round on one side while the other remained flat. Then the side to be rounded would be given the most heating by the manipulation of the electrodes, and the heating be thus localized in the part of the bar where it was most needed.

We do not intend to limit our invention to the precise form of electrode above described, as we may vary it quite widely therefrom, so as to produce the greater heating of the bar 100 on one side than on the other, as described. For example, some of the bowed contact-plates on the frame 11 may be bent or curved down lower than the others where they make contact with the bar 100, so that the pressure on the electrode shall press these upward and bring additional or other spring surfaces into electrical contact with the bar and so increase the contact-surface on the latter. This modification is shown in Fig. 5, where the plate 12^a is bowed farther out than the plate 12, so that pressure upon the electrode will bring the latter into contact with the bar last.

What we claim as new and of our invention is—

1. An electrode for an electric heater, consisting of a frame and a series of superposed flexible elastic bowed contact-plates connected at their opposite ends to said frame. 45
2. An electrode for an electric heater, consisting of a frame and a series of elastic bowed contact-plates connected at their opposite ends to said frame and disposed side by side therein. 45
3. An electrode for an electric heater, consisting of a frame and a series of superposed elastic bowed contact-plates connected at their opposite ends to said frame. 50
4. An electrode for an electric heater, composed of a frame and two or more sets of elastic bowed contact-plates connected at their opposite ends to said frame, said sets being disposed side by side in the frame. 55
5. In an electric heater, the combination of an electrode connected with one electric pole, a free electrode consisting of a frame and a series of elastic bowed contact-plates connected at their opposite ends to said frame, and a flexible conductor for connecting said free electrode with the other electric pole. 60
6. In an electric heater, the combination of an electrode connected with one electric pole, a free electrode consisting of a frame and a series of superposed elastic bowed contact-plates connected at their opposite ends to said frame, and a flexible conductor for connecting said free electrode with the other electric pole. 70

GEO. D. BURTON,
EDWIN E. ANGELL.

Witnesses:

E. F. PHILIPSON,
CHESTER MARR.