



US 20050155535A1

(19) **United States**

(12) **Patent Application Publication**

Rieke et al.

(10) **Pub. No.: US 2005/0155535 A1**

(43) **Pub. Date: Jul. 21, 2005**

(54) **METHOD AND COMPONENTS FOR DRAINING AND TRAPPING**

**Publication Classification**

(75) Inventors: **Larry D. Rieke**, Zionsville, IN (US);  
**Scott A. Beck**, Indianapolis, IN (US)

(51) **Int. Cl.<sup>7</sup> ..... F25C 1/00; F23B 7/00**

(52) **U.S. Cl. .... 110/349**

Correspondence Address:

**Owen D. Marjama**  
**WALL MARJAMA & BILINSKI LLP**  
**Suite 400**  
**101 South Salina Street**  
**Syracuse, NY 13202 (US)**

(57) **ABSTRACT**

The present invention utilizes two specially designed components in the form of a drain tee and a drain tee trap which reduce the chance of vent condensate from entering a furnace inducer. The drain tee includes an integral drain reservoir with a tubing connection for connecting a drain tube when the drain tee trap is not used. The drain tee trap consists of a two-piece sealed trap with a water column pressure trapping capacity and is used in combination with the drain tee.

(73) Assignee: **Carrier Corporation**

(21) Appl. No.: **10/758,709**

(22) Filed: **Jan. 16, 2004**

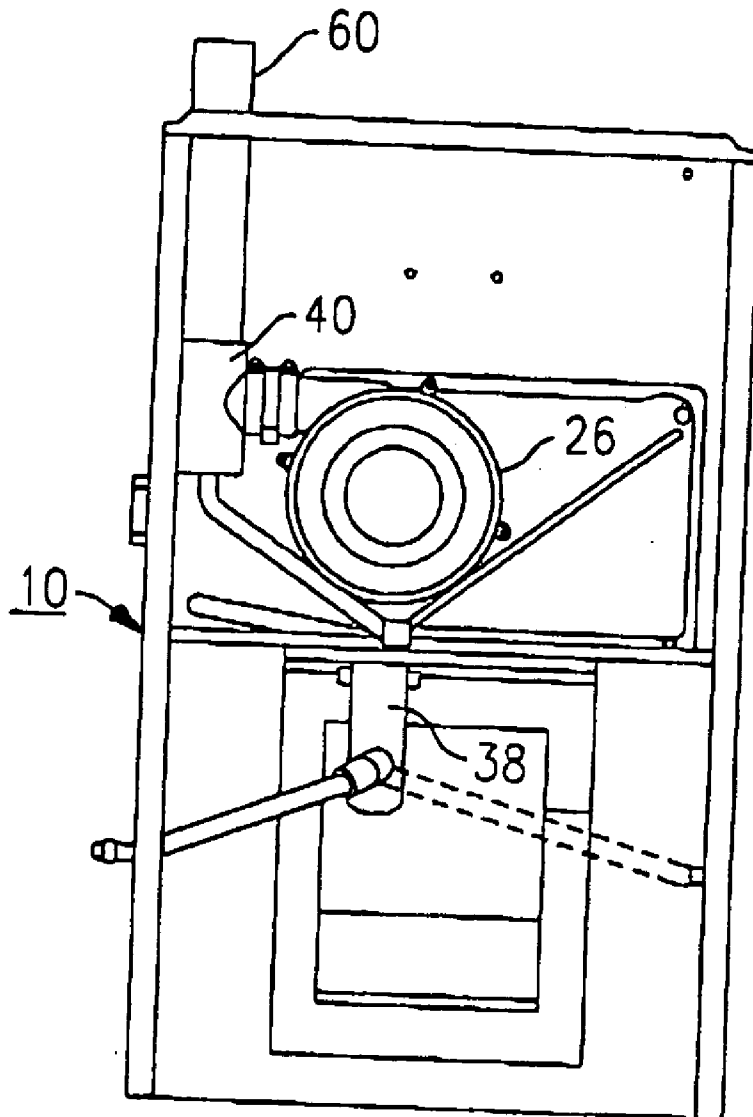

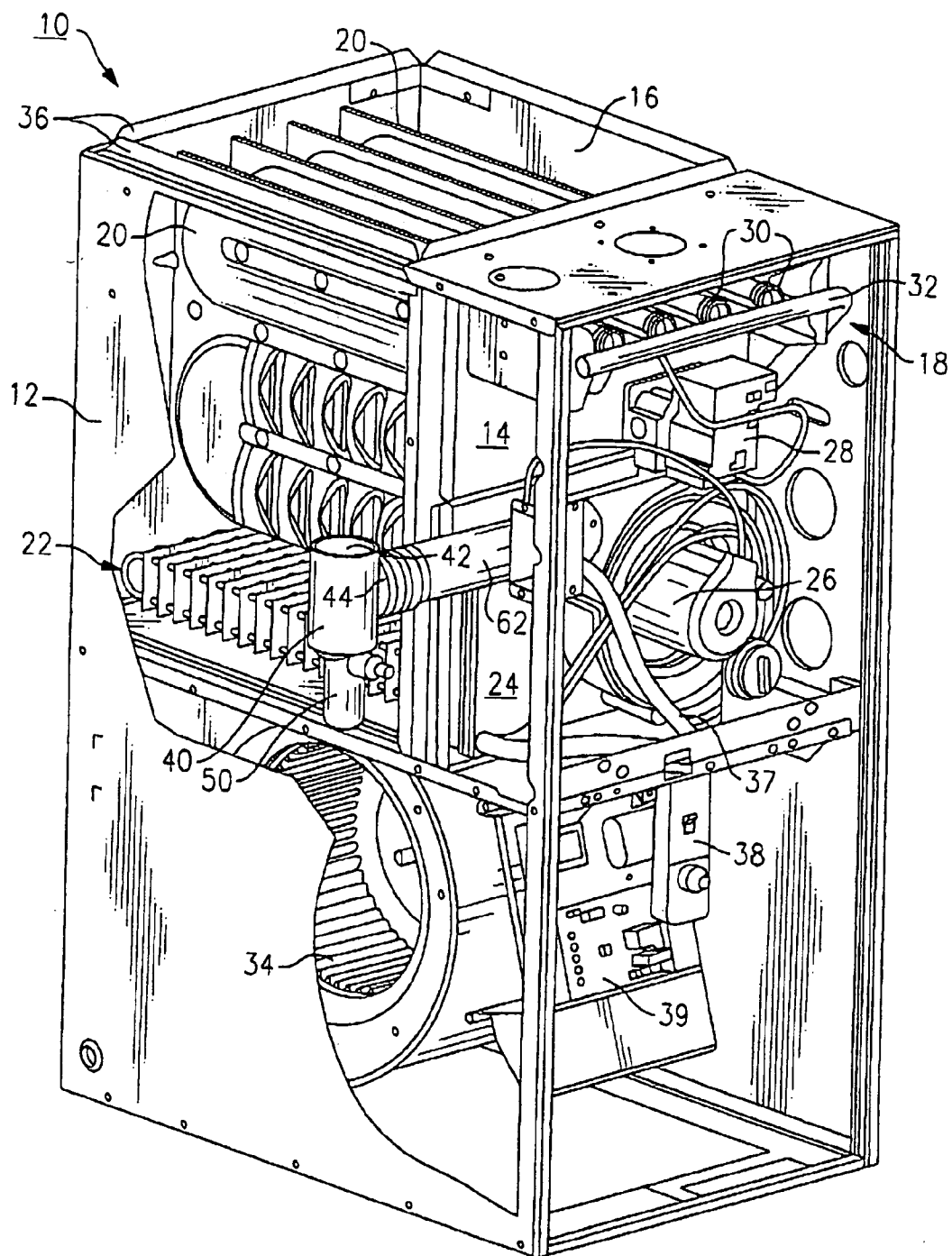
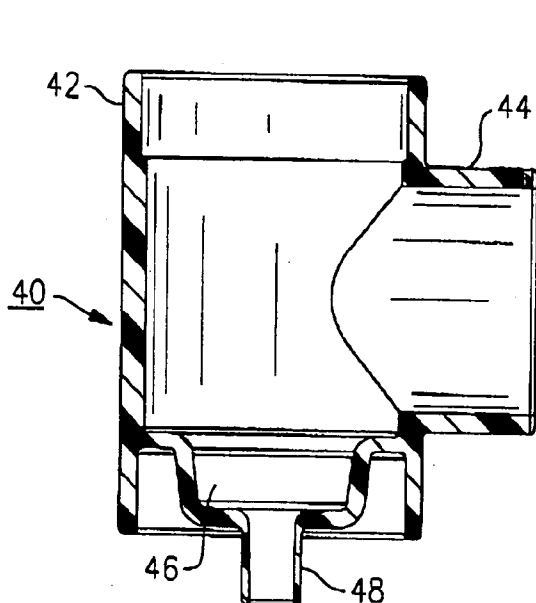
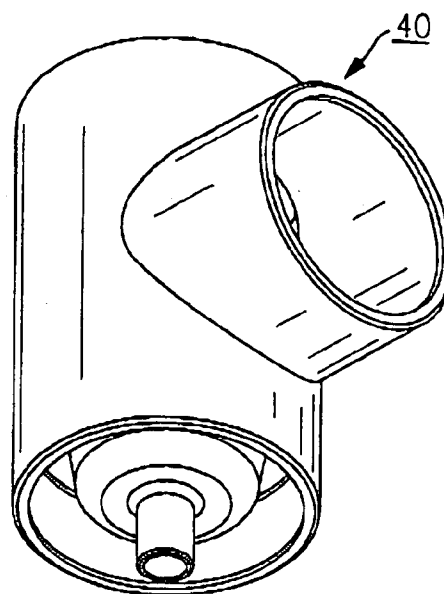

FIG. 1



**FIG. 2A**



**FIG. 2B**

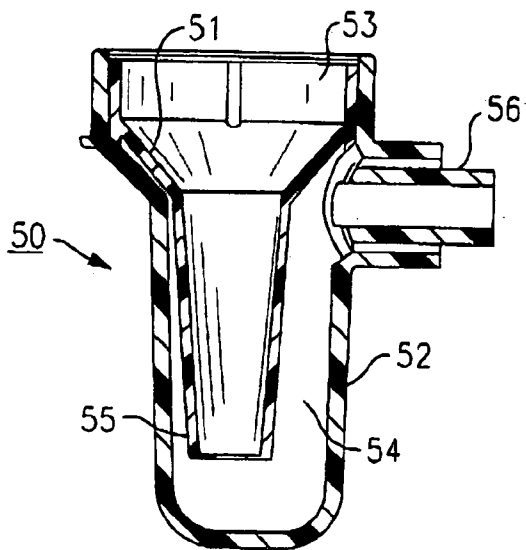

**FIG. 3A**

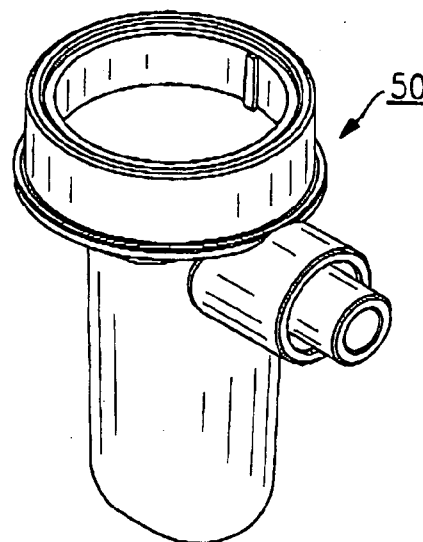

**FIG. 3B**

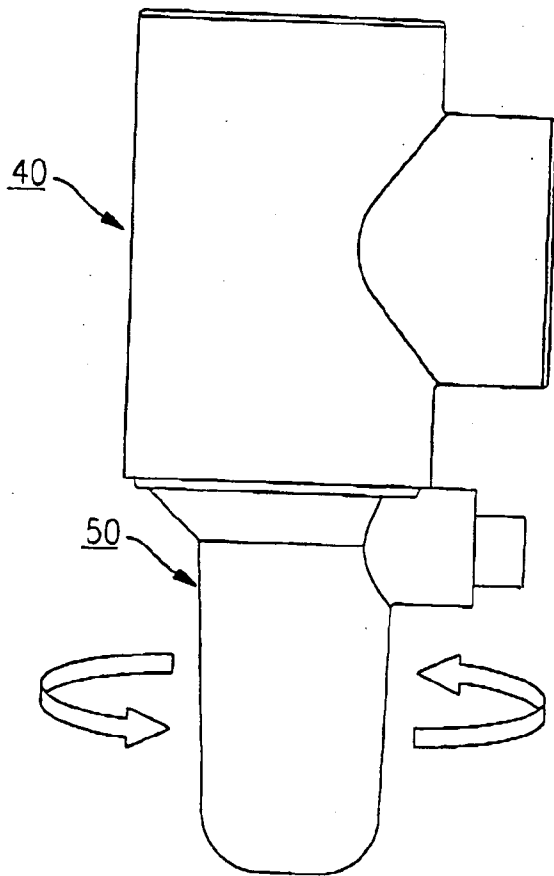

FIG. 4A

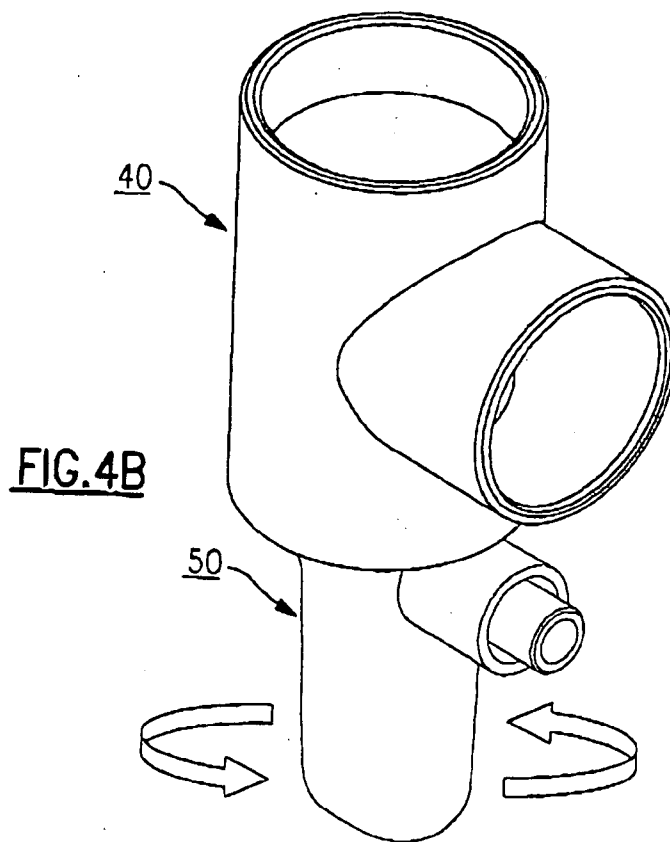
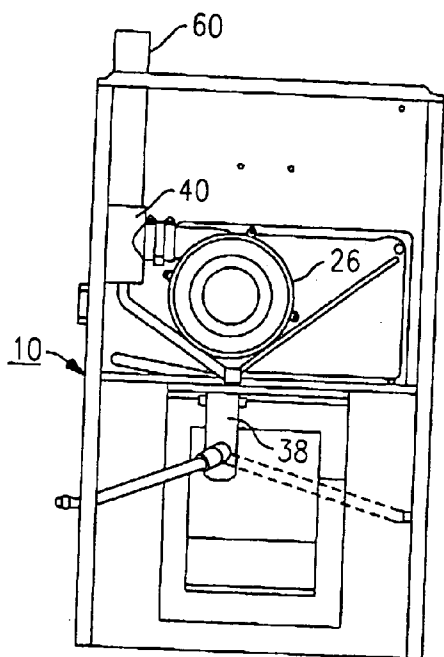
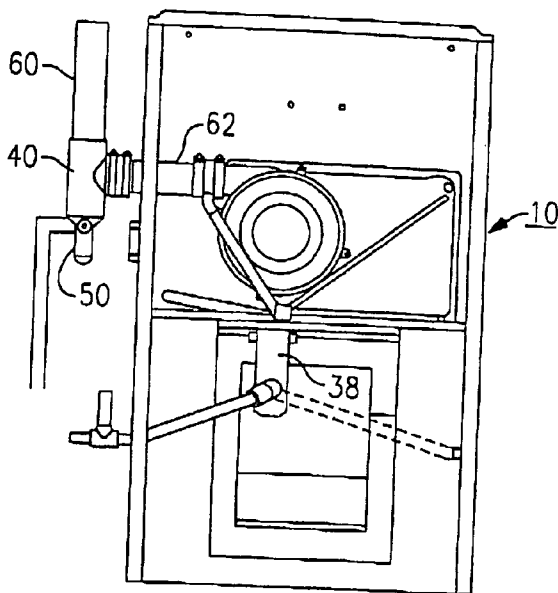

FIG. 4B



**FIG. 5A**



**FIG. 5B**

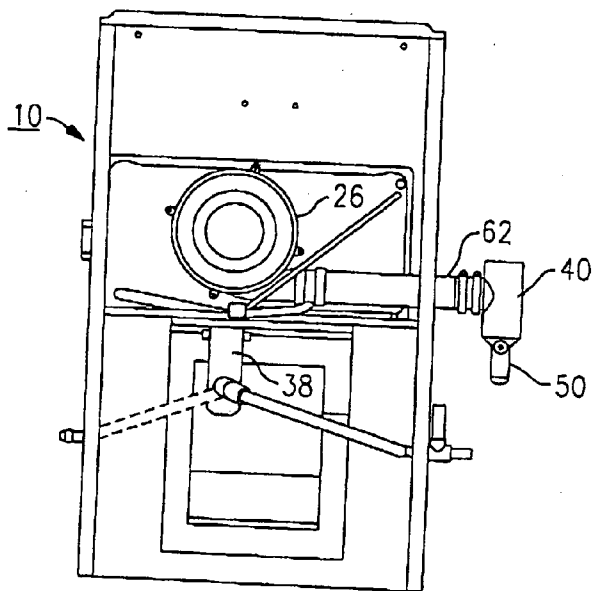

**FIG. 5C**

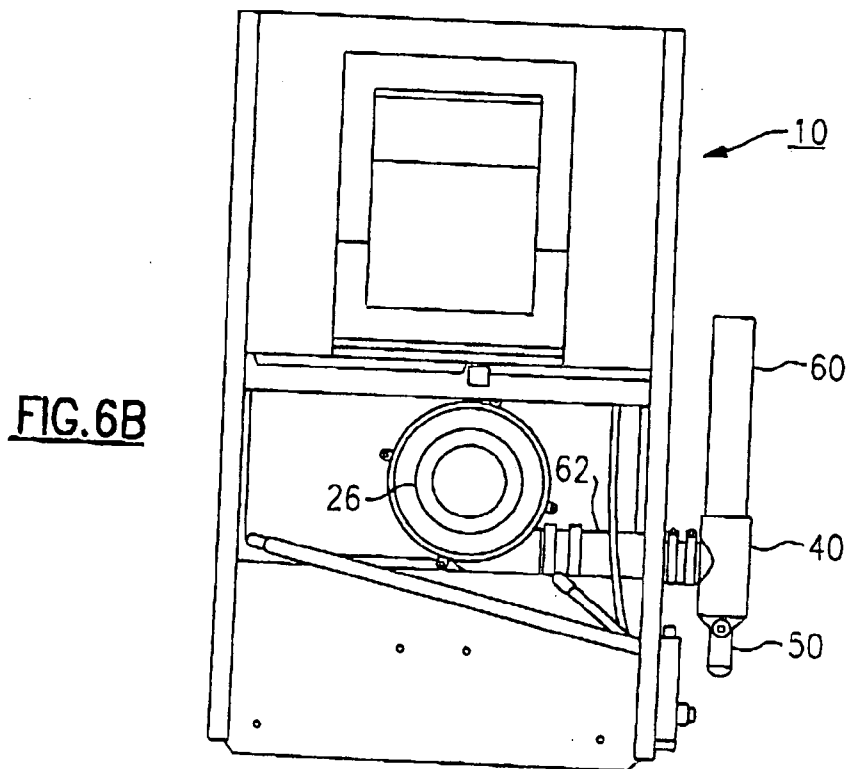
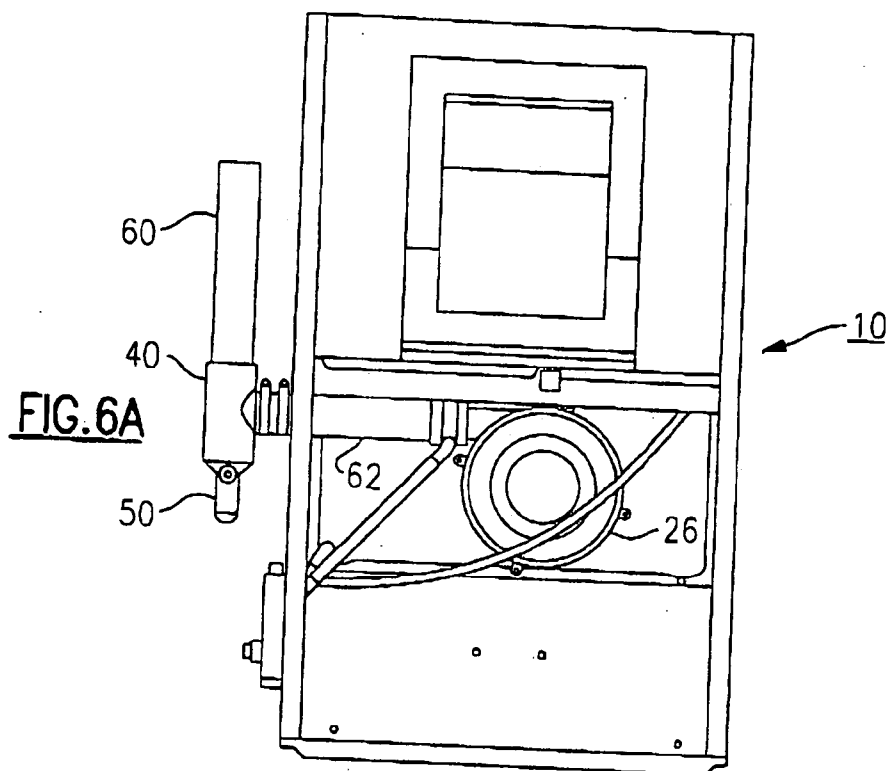

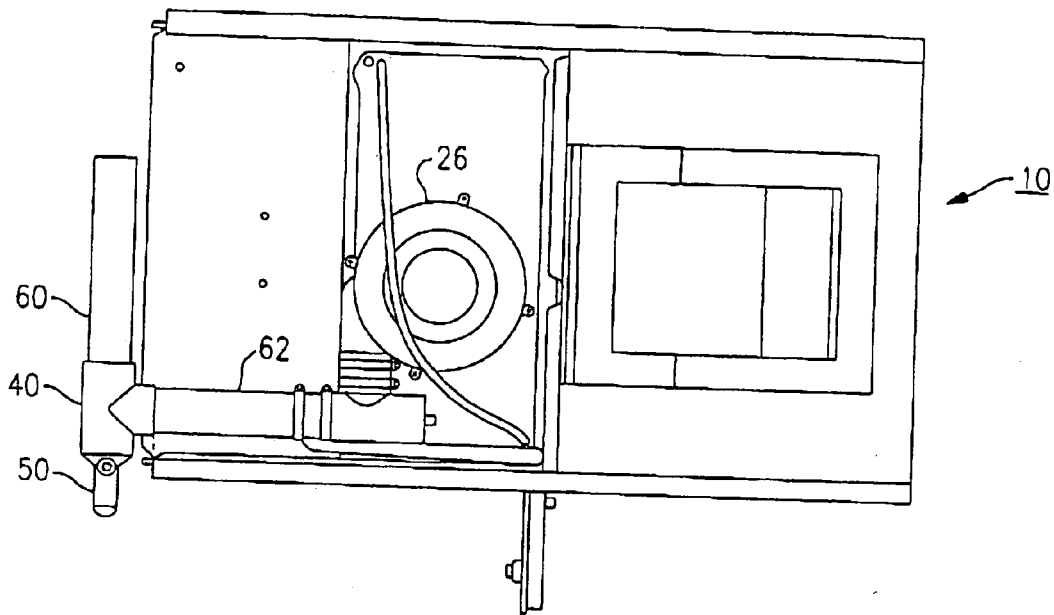

FIG. 7A

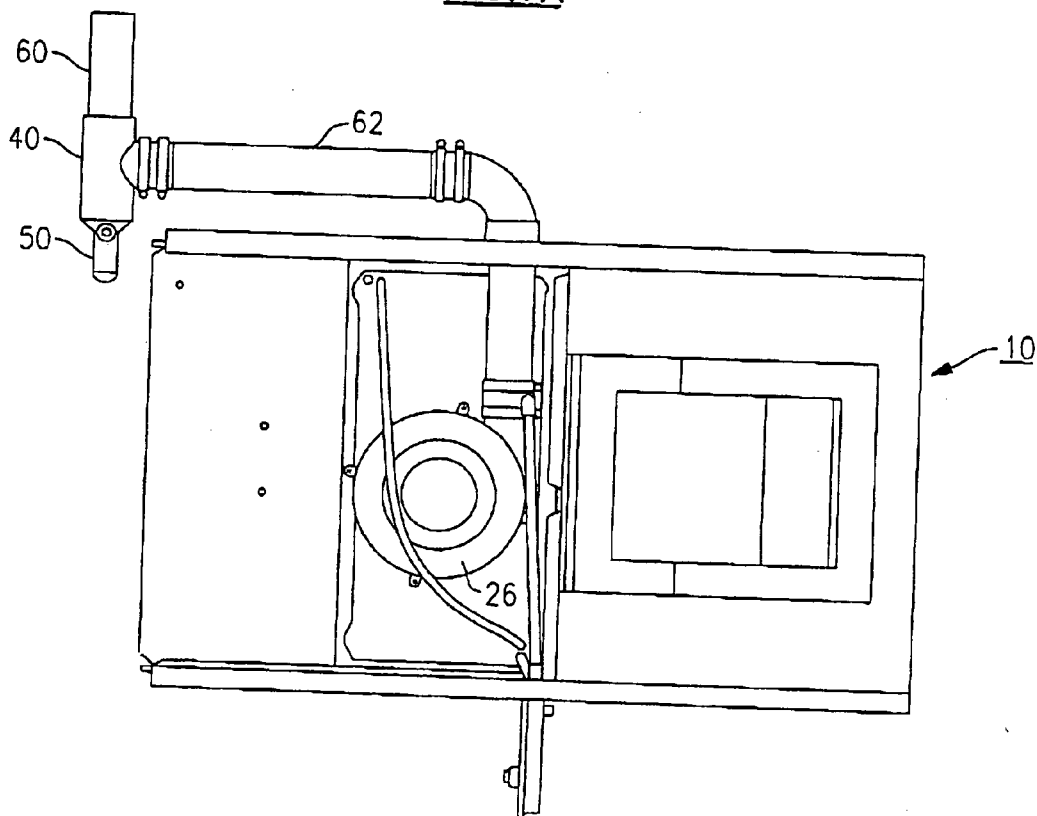
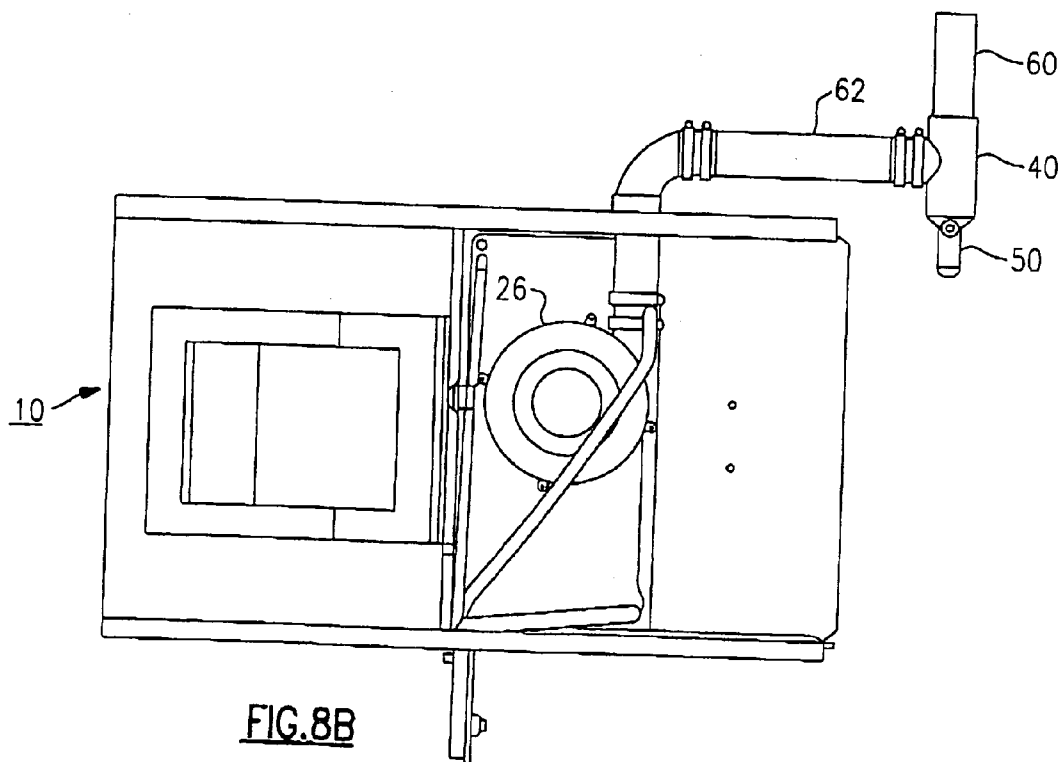
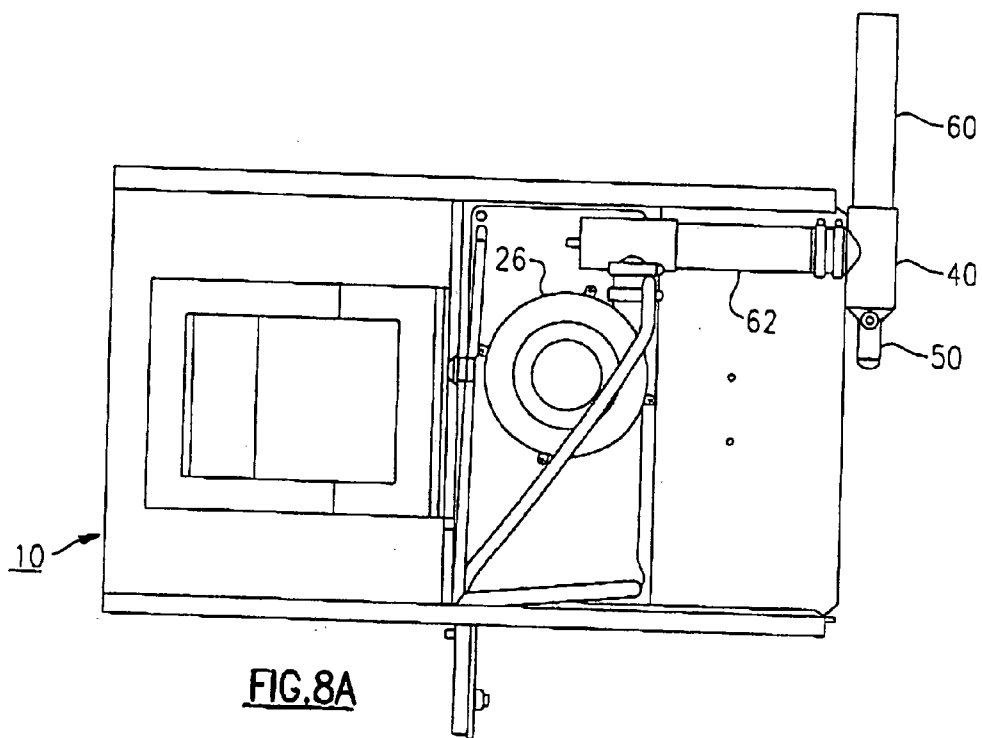

FIG. 7B





## METHOD AND COMPONENTS FOR DRAINING AND TRAPPING

### FIELD OF THE INVENTION

[0001] The invention is directed to draining and trapping vent condensate in residential condensing furnaces.

### BACKGROUND OF THE INVENTION

[0002] The present invention relates in general to a system for preventing vent condensate from entering a furnace inducer, and more specifically to a drain tee and drain tee trap which solve this problem.

[0003] A high percentage of condensing furnaces experience field problems caused by vent condensate collecting in the inducer housing. When this occurs, it can cause the furnace to shut down (no heat) or result in a homeowner complaint due to noise, "water sloshing".

[0004] Most domestic furnace manufactures have vent drainage and trapping capability using a tee, or draining through the inducer to the furnace trap. However, these techniques do not solve all the problems described above.

[0005] In addition to addressing the drainage problems long standing in the field, there is a need for a system which is designed for ease of installation, use on multipoise (4-way) furnaces, and vent drainage internal or external (application/model dependent) to the furnace casing.

### SUMMARY OF THE INVENTION

[0006] It is therefore an objective of the present invention to provide for a draining and trapping system for vent condensate in residential furnaces which overcomes the problems of the prior art described above.

[0007] It is an object of the present invention to provide a system which reduces the chance of vent condensate from entering a furnace inducer.

[0008] It is another object of the present invention to provide a system which provides a flow path away from a furnace inducer outlet to enable the inducer to quickly expel condensate.

[0009] It is yet another object of the present invention to provide an improved drainage system for vent condensate from a furnace which is designed for ease of installation in internal or external applications.

[0010] The present invention utilizes two specially designed component parts: a) drain tee and b) drain tee trap. Using one or both of these components, vent condensate will be trapped and drained in any furnace model/orientation or vent configuration as will be more specifically described herein as will be shown in the drawings.

[0011] The drain tee includes an integral drain reservoir with a tubing connection for connecting drain tube when the drain tee trap is not used. A standard PVC Sch 40 body design with a 90 degree tee is used to minimize back flow of condensate. Standard PVC DWV connection/socket sizes, one 2" PVC pipe size and two 2" PVC fitting size, are used for connection to standard PVC vent materials and to reduce overall height and cost. Shorter (than standard fittings) center connection used for clearance when installed internal to a furnace casing.

[0012] The drain tee trap consists of a two-piece sealed trap with a 2 inch water column pressure trapping capacity. The body volume is minimized to decrease self-priming time while passage widths are maximized to reduce clogging and/or blockage. A standard 2" PVC pipe size inlet connection is used for attachment to the drain tee or to a standard 2" PVC Sch40 or DWV tee. The trap includes an outlet connection compatible with standard 1/2" cts CPVC fittings or standard 3/4" PVC fittings. The trap can be rotated 360 degrees in the tee socket prior to gluing in place. This allows the installer to orient outlet in the optimal direction for drain line attachment.

### BRIEF DESCRIPTION OF THE DRAWINGS

[0013] For a further understanding of these and objects of the invention, reference will be made to the following detailed description of the invention which is to be read in connection with the accompanying drawing, wherein:

[0014] **FIG. 1** is a partial cutaway perspective view of a furnace illustrating the key operative components in accordance with one embodiment of the present invention.

[0015] **FIG. 2A** is a side sectional view of a drain tee of the present invention.

[0016] **FIG. 2B** is a perspective view of the drain tee of **FIG. 2A**

[0017] **FIG. 3A** is a side sectional view of a drain tee trap of the present invention.

[0018] **FIG. 3B** is a perspective view of the drain tee trap of **FIG. 3A**.

[0019] **FIG. 4A** is a side view of the combination drain tee and drain tee trap.

[0020] **FIG. 4B** is a perspective view of **FIG. 4A**.

[0021] **FIG. 5A** is a partial sectional view of a furnace with an upflow installation illustrating an internal drain tee in the top vent mode.

[0022] **FIG. 5B** is a partial sectional view of a furnace illustrating an external left side vent with drain tee and trap.

[0023] **FIG. 5C** is a partial sectional view of a furnace illustrating an external right side vent with drain tee and trap.

[0024] **FIG. 6A** is a partial sectional view of a furnace with a downflow installation having an external left side vent.

[0025] **FIG. 6B** is a partial sectional view of a furnace with a downflow installation having an external right side vent.

[0026] **FIG. 7A** is a partial sectional view of a furnace with a horizontal left installation with an internal drain tee and external drain tee trap with a left side vent.

[0027] **FIG. 7B** is a partial sectional view of a furnace with a horizontal left installation with an external top vent.

[0028] **FIG. 8A** is a partial sectional view of a furnace with a horizontal right installation with an internal drain tee and external drain tee trap with standard tee and right side vent.

[0029] **FIG. 8B** shows the same installation with an external top vent.

DETAILED DESCRIPTION OF THE  
INVENTION

[0030] Referring now to the drawings and initially to FIG. 1, a forced air gas furnace 10 is here shown as a so-called multi-poise condensing furnace. These furnaces can be installed in an erect or upflow configuration, an inverted or downflow configuration, a horizontal right-flow configuration, or a horizontal left-flow configuration. These furnaces include design features which permit efficient operation in any of the four poises or orientations. In addition to ensuring that comfort space air is moved efficiently through the furnace heat exchanger and returned to the comfort space, there must be adequate drainage of condensation from the furnace, and the vent gases must be removed and impelled through the inducer to a vent pipe, and out into the exterior environment.

[0031] More specifically, the furnace 10 as illustrated in FIG. 1 has a cabinet or housing 12 having a vertical cell panel 14 that defines a heat exchanger space 16 behind the cell panel and an equipment space 18 in front of the cell panel 14.

[0032] Heat exchanger element 20 is shown with condenser 22 illustrated and arranged in parallel. The condenser feeds into a collector box 24 which serves as a plenum for combustion gases and also collects condensed water that it receives from the condenser 22.

[0033] An inducer 26 is positioned on the front of the collector box 24 to receive the vent gases from the collector box. The inducer can be rotated to provide vent gas discharge in different directions, one of which is shown. The inducer is contained within an air-tight housing.

[0034] A gas valve 28 meters and controls natural gas flow. The primary heat exchanger 20 consists of several parallel cells, each forming a serpentine path that leads into the condensers 22. A burner assembly contains a plurality of gas burners 30 that receive gas feed from the valve 28 and associated gas manifold 32. The burners inject flame through respective openings so that hot combustion products pass through the primary heat exchanger 20 and condenser heat exchanger 22 where the combustion products heat circulation air that passes over the condensers and cells.

[0035] A circulation blower 34 disposed below the heat exchanger forces comfort-space circulation air through the heat exchanger compartment 16 through an air supply duct connection 36 in a well known manner, and the heated circulation air returns through conventional ductwork (not shown) to the comfort space. A condensate drain tube 37 connects the drain tee and/or drain tee trap with furnace drain tarp 38. Control board 39 provides for the control and function of the various components of the furnace described herein.

[0036] To accommodate the multi-poise capability of this furnace, the inducer typically can be rotated to orient the vent connection in the desired direction.

[0037] The condenser stage of the furnace heat exchanger has a front plenum or collector box into which passes condensed moisture from the combustion products and also all remaining gaseous combustion products. A vent gas port (not shown) is formed at the center of the collector box front wall. Two or more condensate drain taps (not shown) are

provided, disposed at corners of the collector box to drain off the condensate from the condensing heat exchanger. Depending on the poise selected, one or another of these drain taps will be lowermost and this tap is connected to a drain tube. Any remaining drain taps are capped off.

[0038] The inducer includes a centrifugal fan (not shown) contained within an airtight housing, with an intake port situated centrally on the wall of the housing that faces the collector box of the condensing heat exchanger.

[0039] In FIG. 1 the combination drain tee 40 and drain tee trap 50 are shown connected to furnace inducer 26 by vent coupling 62 to side connection 44 of drain tee 40. The drain tee is positioned for connection to a vertical vent pipe 60 (FIGS. 5A-8B) through upper connecting socket 42.

[0040] The drain tee 40 and drain tee trap 50 of the present invention is used in conjunction with the furnace inducer to be used in various designs for multi-poise internal/external drainage incorporating all of the features which will be described herein and are illustrated in the accompanying drawings. In using one or both of the drain tee or drain tee trap, vent condensate will be trapped and drained in any of the furnace model/orientations and vent configurations as illustrated herein.

[0041] As shown in FIG. 2A the drain tee 40 is in the form of a unitized body having an upper socket 42 which is adapted for connection to a vertical or side drain vent pipe, a side connection 44, an integral drain reservoir 46 having a drain tap 48 for connection to a connecting drain tube when the drain tee trap is not used. A perspective view of the drain tee 40 is illustrated in FIG. 2B.

[0042] The drain tee trap 50 (FIG. 3A) comprises a two piece sealed trap having an outer body or shell 52 and a funnel shaped inner section 51 which together defines a reservoir 54 and side tap 56 for an outlet connection. The funnel shaped inner section 51 having an upper inlet connection 53 for attachment to the drain tee and an outlet 55 at its bottom. A perspective view of the drain tee trap is shown in FIG. 3B.

[0043] FIGS. 4A and 4B illustrate the combination of the drain tee and drain tee trap with the top of the drain tee trap engaged with the bottom of the drain tee. The two components are designed so that the trap can be rotated 360 degrees in the tee socket prior to gluing in place. This allows the installer to orient the outlet in the optimum direction for drain line attachment.

[0044] As shown in 5A, 5B and 5C, FIG. 5A illustrates an arrangement in which the drain tee 40 is connected from the inducer 26 and vented upwardly through vent 60 while the drain tap 48 on the bottom of the drain tee is connected to the tee drain tube and exits through the furnace drain trap 38. FIG. 5B the tee in combination with the tee drain trap is connected to the furnace and vents flue gas vertically, while trapping and draining vent condensate to a drain connection. NOTE: Implementing the drain tee & trap as shown allows drainage of vent condensate directly into typical household draining without further trapping. Past practice would be: 1) Installer make own trap by "looping" a drainline (more work not as robust, more space); and 2) Condensate routed back into furnace and through furnace trap. FIG. 5C illustrates an external right side vent with drain tee and trap. FIGS. 6A and 6B; 8A and 8B; and 7A and 7B illustrate various

installation orientations which utilize the tee and drain trap. These various configurations and positions provide advantageous options for furnace installation in which space, constraints and code requirements require various options in order to accomplish proper venting and drainage.

[0045] The design of the present invention has the versatility/flexibility to provide drainage and trapping in a wide variety of applications with a minimum special parts. The following configurations illustrate the many advantageous applications of the invention:

- [0046] Upflow, top vent, using Tee and furnace trap inside furnace.
- [0047] Upflow, left-side vent, using Tee and integral tee trap outside furnace.
- [0048] Upflow, right-side vent, using Tee and integral tee trap outside furnace.
- [0049] Downflow, left-side vent, using Tee and integral tee trap outside furnace.
- [0050] Downflow, right-side, Tee and integral tee trap outside furnace.
- [0051] Left-hand horizontal, top vent, Tee integral tee trap outside furnace.
- [0052] Left-hand horizontal, end vent, Tee integral tee trap outside furnace.
- [0053] Right-hand horizontal, top vent, Tee and integral tee trap outside furnace.
- [0054] Right-hand horizontal, end vent, Tee and integral tee trap outside furnace.

[0055] Additionally, the integral tee trap can be rotated to provide drainage in desired direction and also used with a standard off-the-shelf tee to provide drainage and trapping.

[0056] The Tee is designed to combine the wall thicknesses of standard Schedule 40 PVC fittings with the small socket size of standard DWV PVC fittings to create a more compact design with maximum strength and compatible with standard PVC pipe and components.

[0057] Together, the parts provide a drainage and trapping system that is adaptable to more installation configurations than prior art.

[0058] In a further application, the ICP top of the line deluxe furnaces have a wide casing and the tee can be used inside the furnace for top venting (FIG. 5A) or outside like 5B & C. The ICP standard furnaces (less expensive models) are narrower and can only be installed with the tee (and trap) outside the casing (FIGS. 5B & C). This is an important difference because upflow (FIGS. 5A, B & C) comprises 80% of installations. Since these models compete in price-sensitive markets, reducing costs by not shipping the special Tee in the standard units and allow the installer to use an off-the-shelf tee is a valuable option. It can therefore be seen that the Tee's flexibility allows us to provide differentiation in a tiered product line while using minimum special parts.

[0059] While the present invention has been particularly shown and described with reference to the preferred mode as

illustrated in the drawing, it will be understood by one skilled in the art that various changes in detail may be effected therein without departing from the spirit and scope of the invention as defined by the claims.

We claim:

1. A system for draining and trapping vent condensate in a multipoise furnace in which a one piece drain tee is connected to an inducer and vented outwardly while the bottom of the tee contains means for connection to a tee drain tube which is connected to and exits through a furnace drain trap, wherein said tee includes an integral drain reservoir having a bottom drain tap, with said drain tee further including means for connection to said inducer and to an outward vent.

2. The system of claim 1 in which said furnace is an upflow installation with an internal drain tee in a top vent mode.

3. A system for draining and trapping vent condensate in a multipoise furnace in which a combination drain tee/drain tee trap is connected to an inducer and vented outwardly, wherein said drain tee further includes an integral drain reservoir, and means for connection to said inducer and an outward vent, and where said drain tee trap is connected to the bottom of said drain tee and includes a two piece sealed trap, and water column pressure trapping means.

4. The system of claim 3 in which said drain tee trap includes an outlet connection adapted for connection to a drain.

5. The system of claim 3 in which said furnace has an external left side vent with said drain tee and trap.

6. The system of claim 3 in which said furnace has an external right side vent with said drain tee and trap.

7. The system of claim 3 in which said furnace has a downflow installation having an external left side vent.

8. The system of claim 3 in which said furnace has a downflow installation having an external right side vent.

9. The system of claim 3 in which said furnace has a horizontal left installation with an internal drain tee and external drain tee trap with a left side vent.

10. The system of claim 3 in which said furnace has a horizontal left installation with an external top vent.

11. The system of claim 3 in which said furnace has a horizontal right installation with an internal drain tee and external drain tee trap with a right side vent.

12. The system of claim 3 in which said furnace has an external top vent.

13. A combination drain tee/drain tee trap suitable for use in a system for draining and trapping vent condensate in a multipoise furnace wherein said drain tee comprises an outer housing which includes an integral drain reservoir and bottom drain trap, and means for connection to a furnace inducer and an outward vent, and where said drain tee trap is connected in sealed engagement to the bottom of said drain tee and includes a sealed trap, and water column pressure trapping means.

14. The combination drain tee/drain tee trap of claim 12 in which the drain tee trap includes an outlet connection adapted for connection to a drain.

\* \* \* \* \*