

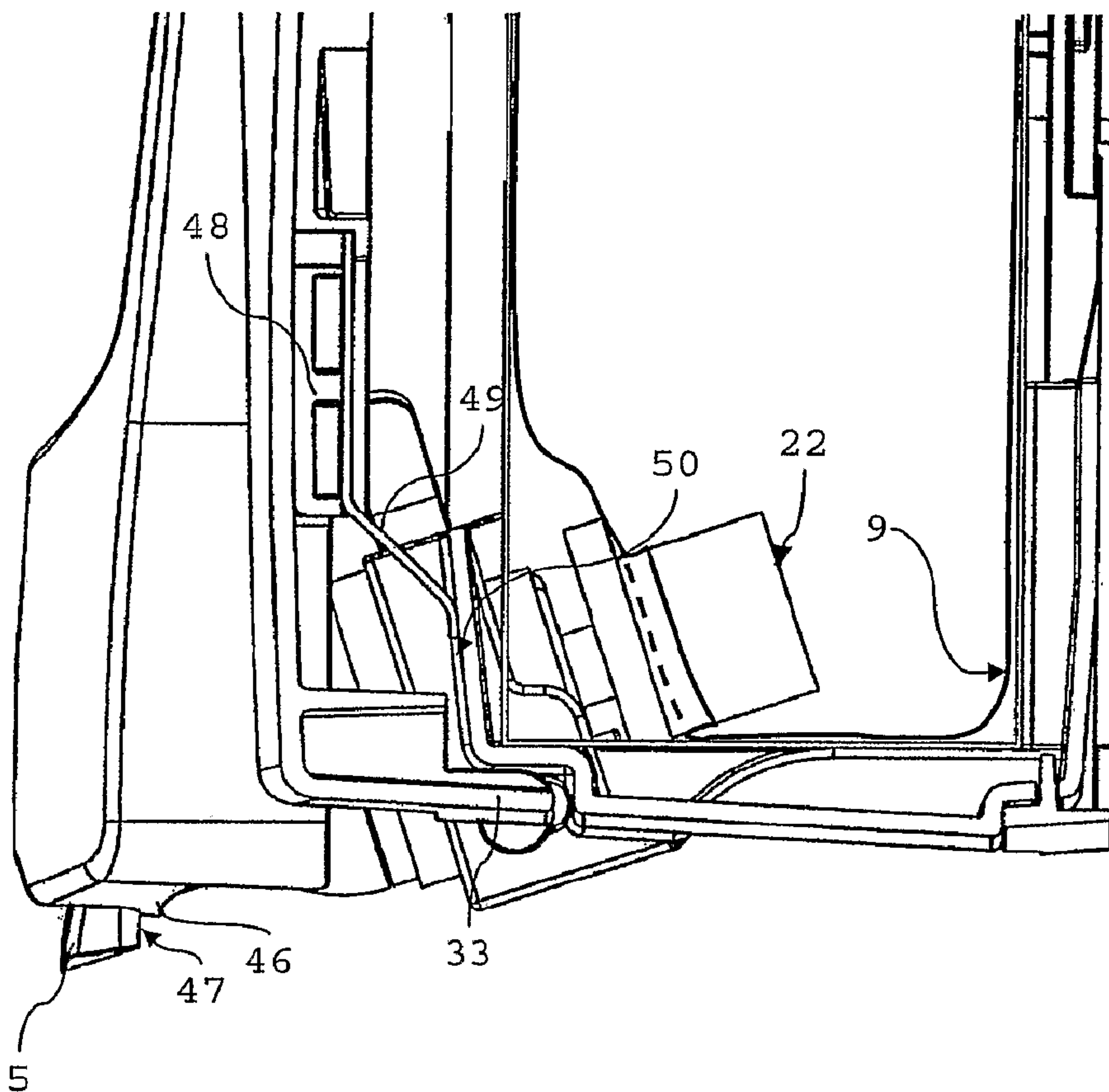

(86) Date de dépôt PCT/PCT Filing Date: 2002/11/11
 (87) Date publication PCT/PCT Publication Date: 2003/07/24
 (45) Date de délivrance/Issue Date: 2009/06/23
 (85) Entrée phase nationale/National Entry: 2004/05/03
 (86) N° demande PCT/PCT Application No.: NL 2002/000724
 (87) N° publication PCT/PCT Publication No.: 2003/059524
 (30) Priorité/Priority: 2001/11/12 (NL1019348)

(51) Cl.Int./Int.Cl. *A47K 5/14* (2006.01),
B05B 11/00 (2006.01)
 (72) Inventeur/Inventor:
GANZEBOOM, WILHELMUS EVERHARDUS, NL
 (73) Propriétaire/Owner:
TECHNICAL CONCEPTS BENTFIELD B.V., NL
 (74) Agent: SIM & MCBURNEY

(54) Titre : DISTRIBUTEUR DE MOUSSE, SON LOGEMENT ET SON SUPPORT DE STOCKAGE
 (54) Title: FOAM DISPENSER, HOUSING AND STORAGE HOLDER THEREFOR



(57) Abrégé/Abstract:

A foam dispenser comprises a housing (2), a fluid reservoir (8) placed in the housing (2), having an opening, a plug (22) connected to the fluid reservoir (8) in the opening, and a foam pump (6), comprising an air pump, a fluid pump, a closable supply to the air

(57) **Abrégé(suite)/Abstract(continued):**

pump, a nozzle (5), and a moveable operating part (11), wherein the foam pump (6) dispenses a quantity of foam through the nozzle (5) upon actuation of the operating part (11) in a direction of pumping, wherein the foam pump (6) and the fluid reservoir (8) are combined into a removable storage holder. The foam dispenser comprises a coupling piece (23) connected to the foam pump, with which the removable storage holder is fastened to the housing (2).

(12) INTERNATIONAL APPLICATION PUBLISHED UNDER THE PATENT COOPERATION TREATY (PCT)

(19) World Intellectual Property Organization
International Bureau(43) International Publication Date
24 July 2003 (24.07.2003)

PCT

(10) International Publication Number
WO 03/059524 A1

- (51) International Patent Classification⁷: **B05B 11/00**,
A47K 5/14
- (54) Agent: **DE VRIES, Johannes, Hendrik, Fokke**; De Vries & Metman, Overschiestraat 180, NL-1062 XK Amsterdam (NL).
- (21) International Application Number: PCT/NL02/00724
- (81) Designated States (*national*): AE, AG, AL, AM, AT, AU, AZ, BA, BB, BG, BR, BY, BZ, CA, CH, CN, CO, CR, CU, CZ, DE, DK, DM, DZ, EC, EE, ES, FI, GB, GD, GE, GH, GM, HR, HU, ID, IL, IN, IS, JP, KE, KG, KP, KR, KZ, LC, LK, LR, LS, LT, LU, LV, MA, MD, MG, MK, MN, MW, MX, MZ, NO, NZ, OM, PH, PL, PT, RO, RU, SD, SE, SG, SI, SK, SL, TJ, TM, TN, TR, TT, TZ, UA, UG, US, UZ, VC, VN, YU, ZA, ZM, ZW.
- (22) International Filing Date:
11 November 2002 (11.11.2002)
- (84) Designated States (*regional*): ARIPO patent (GH, GM, KE, LS, MW, MZ, SD, SL, SZ, TZ, UG, ZM, ZW), Eurasian patent (AM, AZ, BY, KG, KZ, MD, RU, TJ, TM), European patent (AT, BE, BG, CH, CY, CZ, DE, DK, EE, ES, FI, FR, GB, GR, IE, IT, LU, MC, NL, PT, SE, SK, TR), OAPI patent (BF, BJ, CF, CG, CI, CM, GA, GN, GQ, GW, ML, MR, NE, SN, TD, TG).
- (25) Filing Language: Dutch
- (26) Publication Language: English
- (30) Priority Data:
1019348 12 November 2001 (12.11.2001) NL
- (71) Applicant (*for all designated States except US*): **BENT-FIELD EUROPE B.V.** [NL/NL]; Ampèrestraat 12, NL-2181 HB Hillegom (NL).
- (72) Inventor; and
(75) Inventor/Applicant (*for US only*): **GANZEBOOM, Wilhelmus, Everhardus** [NL/NL]; Zonnelaan 4, NL-2012 TC Haarlem (NL).
- Published:
— with international search report

[Continued on next page]

(54) Title: FOAM DISPENSER, HOUSING AND STORAGE HOLDER THEREFOR

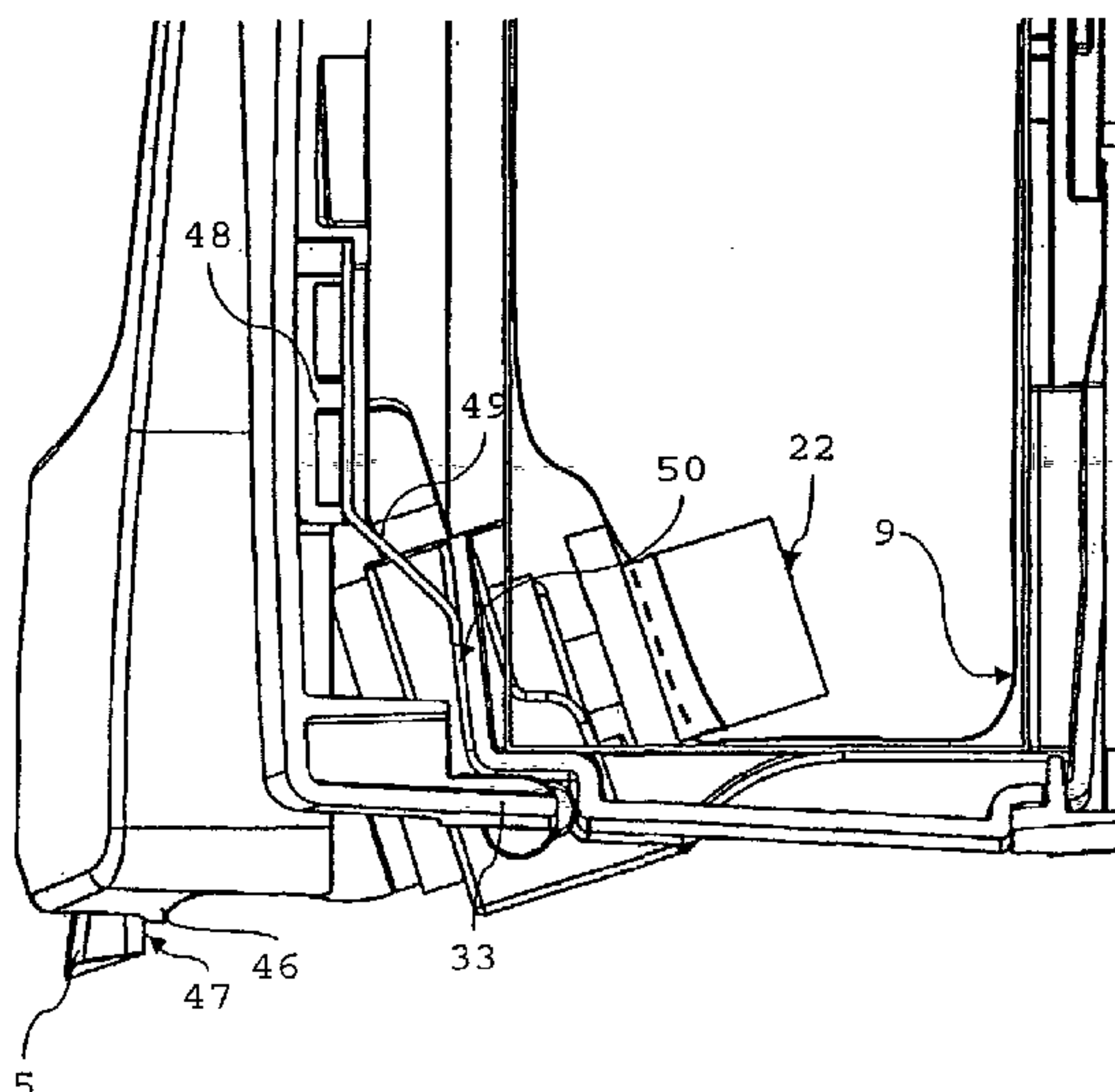

(57) Abstract: A foam dispenser comprises a housing (2), a fluid reservoir (8) placed in the housing (2), having an opening, a plug (22) connected to the fluid reservoir (8) in the opening, and a foam pump (6), comprising an air pump, a fluid pump, a closable supply to the air pump, a nozzle (5), and a moveable operating part (11), wherein the foam pump (6) dispenses a quantity of foam through the nozzle (5) upon actuation of the operating part (11) in a direction of pumping, wherein the foam pump (6) and the fluid reservoir (8) are combined into a removable storage holder. The foam dispenser comprises a coupling piece (23) connected to the foam pump, with which the removable storage holder is fastened to the housing (2).

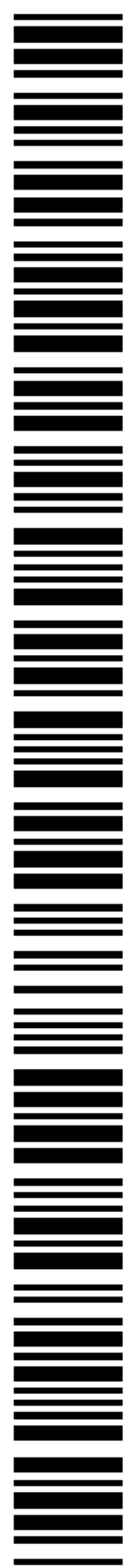

WO 03/059524 A1

WO 03/059524 A1



For two-letter codes and other abbreviations, refer to the "Guidance Notes on Codes and Abbreviations" appearing at the beginning of each regular issue of the PCT Gazette.

Foam dispenser, housing and storage holder therefor

The invention relates to a foam dispenser, comprising a housing, a fluid reservoir placed in the housing, having an opening, a plug connected to the fluid reservoir in the opening and a foam pump, comprising an air pump, a fluid pump, a closable supply to the air pump, a nozzle, and a moveable operating part, wherein the foam pump dispenses a quantity of foam through the nozzle upon actuation of the operating part in a direction of pumping, wherein the foam pump and the fluid reservoir are combined into a removable storage holder.

The invention also relates to a housing for a foam dispenser, suitable for placement of a removable fluid reservoir and a foam pump, and arranged for operation of the foam pump.

Furthermore, the invention also relates to a storage holder, e.g. for liquid soap, destined for placement in a foam dispenser, and comprising a fluid reservoir having an opening, a plug, connected to the fluid reservoir in the opening and a foam pump, comprising an air pump, a fluid pump, a closable supply to the air pump, a nozzle and a moveable operating part, wherein the foam pump dispenses a quantity of foam through the nozzle upon actuation of the operating part in a direction of pumping.

Soap dispensers with foam pumps can, in general, be divided into two categories. Certain variants are in use in hand soap dispensers, consisting of a flexible standing can. In an opening at the top of the can, there is screwed a foam pump, having a nozzle pointing downwards and a dip tube, which extends at least partly into the can. The pump is therefore located above the level of the fluid reservoir. The soap is

pumped upwards. At the same time, air flows into the can via an air supply in the pump, to prevent a vacuum being established in the can. Such a soap dispenser must always be used standing up. If it is held upside down, soap flows through the air supply. There is also a chance of contamination from outside, by means of which the air supply can be blocked. For this reason, lengthy use of the pump and dispenser is not well possible.

In a different type of soap dispenser having a foam pump the fluid reservoir is located above the level of the pump. This variant is especially suited for fitting in a bathroom or toilet. The fluid reservoir is used to store the liquid soap and is replaceable, so that the foam dispenser can be recharged. In this variant, the pump is fixedly attached to the housing. For this reason, the pump is of a much more robust type. Because the fluid reservoir is located above the level of the pump, parts of the pump continually contact the fluid, due to gravitational effects, and can thus be harmfully affected. The pump must also last much longer, namely as long as is needed to pump away the contents of a number of the replaceable fluid reservoirs. Replacement of the pump entails having to replace the entire housing and is therefore costly.

WO 95/26831 describes a fluid dispenser for dispensing foam. The device comprises a collapsible fluid container and a foam pump attached to the container outlet. The foam pump comprises two enclosures. The first is connected to the neck of the container and the second is telescopically received in the first. In assembled state, the two enclosures define an air chamber and a fluid chamber, each having an outlet, which join together at the foam outlet. The fluid dispenser comprises a dispenser housing for detachably receiving the collapsible container and the foam pump. The

foam pump need therefore be less robust, as the fluid reservoir and pump can both be replaced after use.

A disadvantage of the known apparatus is that the foam pump has been designed especially for this application. The foam pump is only suitable for application in one sort of housing. This makes production of the pump much less economical, as it is manufactured in a small series, especially for this application. When one wants to make different versions of housing and storage holder, for example to provide dispensers for different types of fluid, different types of pump and housing must be made, which further reduces the production series of both the pump and the housing and thus makes manufacturing less economical.

US 6 082 586 discloses a liquid dispenser including a housing enclosing an upper liquid dispenser compartment and a lower compartment housing a foam producing pump. The dispenser is designed to releasibly receive therein a liquid container comprising a liquid storage compartment and a liquid outlet or throat. Attached in the throat of the container is a foam pump. The foam pump includes a cup-shaped enclosure member having a top portion with an aperture or fluid inlet centrally located therein. The enclosure includes a shoulder against which the edge of the throat of the container abuts when the pump is assembled with the container. The outer diameter of the cup-shaped enclosure and the inner diameter of the throat of the liquid container are chosen so the enclosure can be inserted into the throat with a snug fit with the throat edge bearing against the shoulder. The cup-shaped enclosure is then welded to the container to permanently attach it thereto. A cylinder and the cup-shaped enclosure, when assembled, define an air chamber which can be pressurised by pushing a piston

Insertion sheet A

[new paragraph]

US 6 082 586 discloses a liquid dispenser including a housing enclosing an upper liquid dispenser compartment and a lower compartment housing a foam producing pump. The dispenser is designed to releasibly receive therein a liquid container comprising a liquid storage compartment and a liquid outlet or throat. Attached in the throat of the container is a foam pump. The foam pump includes a cup-shaped enclosure member having a top portion with an aperture or fluid inlet centrally located therein. The enclosure includes a shoulder against which the edge of the throat of the container abuts when the pump is assembled with the container. The outer diameter of the cup-shaped enclosure and the inner diameter of the throat of the liquid container are chosen so the enclosure can be inserted into the throat with a snug fit with the throat edge bearing against the shoulder. The cup-shaped enclosure is then welded to the container to permanently attach it thereto. A cylinder and the cup-shaped enclosure, when assembled, define an air chamber which can be pressurised by pushing a piston inwardly into a tube within the enclosure. Thus, the enclosure is part of the pump as well as forming a plug to attach the foam pump into the throat of the container.

[new paragraph]

Insertion sheet B

with the aid of which the foam pump is coupled to the fluid reservoir and

inwardly into a tube within the enclosure. Thus, the enclosure is part of the pump as well as forming a plug to attach the foam pump into the throat of the container.

It is an object of the invention to provide an
5 alternative foam dispenser, housing for a foam dispenser and storage holder of the type mentioned above, which can be manufactured more easily and more efficiently.

To this end the foam dispenser according to the invention wherein the foam dispenser comprises a coupling
10 piece, connected to the foam pump, with the aid of which the foam pump is coupled to the fluid reservoir and with which the removable storage holder is fastened to the housing.

Thus, the foam dispenser has a modular build. It is
15 easy to use a different pump, because only an adjustment to the coupling piece is necessary. For this reason, pumps can be used which are also produced for other purposes.

The housing according to the invention wherein the
20 housing comprises an adapter for attachment of a coupling piece connected to the foam pump with the aid of which the foam pump is coupled to the fluid reservoir.

This fits within the modular concept of the invention, as in this way, one type of housing can be
25 used for different types of storage holder. The housing need only comprise an adapter associated with the coupling piece.

The storage holder according to the invention wherein the storage holder comprises a coupling piece,
30 connected to the foam pump, with the aid of which the foam pump is coupled to the fluid reservoir and with which the removable storage holder can be fastened in the foam dispenser.

4a

This aspect of the invention is also part of the modular concept. By means of the coupling piece, it is, amongst others, possible to make use of existing pumps which are already manufactured in large series. It is also possible to use different variants of the pump, by using an adapted coupling piece.

According to an aspect of the invention, the housing is provided with an adapter, in which the coupling piece is received, wherein the coupling piece and the adapter are provided with one or more means for fixing and positioning the foam pump.

By these means, it is ensured that the foam always emerges from the foam dispenser in the right direction. For example, if the user must hold his hand underneath it, the nozzle should always point downwards. This is automatically ensured, as the reservoir with pump and coupling piece can only be positioned in the adapter in one manner.

Preferably, the adapter is provided with resilient means which are supported by the coupling piece and with one or more latches which restrain the coupling piece in the adapter under tension.

When the storage holder needs to be replaced, the coupling piece is released and at least partly pushed out of the adapter by the resilient means. This ensures a more comfortable removal from the storage holder.

According to a further aspect of the invention, the housing is provided with a handle, mechanically contacting the

operating part of the foam pump, for transferring a force in the direction of pumping.

The user of the dispenser therefor pumps by exerting a force on the handle. This has the advantage that the operating part of the pump need not be directly operated. On the one hand this allows to provide a handle with a larger operating surface, which is more comfortable in operation. On the other hand, it is thus possible to shield the pump from its surroundings, as it need not be accessible to a user. In this way, contamination of the supply to the air pump, for example by the wet hands of a user, is avoided.

Preferably, the handle is coupled to the operating part and the foam dispenser is further provided with resilient means, supported by the housing and exerting a force opposed to the direction of pumping on the handle.

This has the effect of returning the pump to a starting position without leaks after each stroke of the pump, including when the pump starts to move more brusquely towards the end of its lifetime.

According to another aspect of the invention the nozzle is part of the operating part and the handle is provided with means for aligning the nozzle.

The foam therefore always leaves the dispenser in the right direction and the user is not surprised by foam landing next to his hands.

According to an aspect of the storage holder according to the invention, the fluid reservoir has a flexible wall, with which the foam pump is connected in a substantially airtight manner.

Thus, no air channel is needed for pressure compensation inside the reservoir, as the reservoir is capable of deforming, as it empties, until ultimately it is almost

completely evacuated. Due to airtight connection, no soap can flow through air channels, for instance under influence of gravity.

In an embodiment of a storage holder according to the invention, the coupling piece comprises a threaded neck and the foam pump comprises a matching thread, with which the foam pump is attached to the coupling piece.

In this way it is possible, with the aid of the coupling piece, to couple a pump to the fluid reservoir, which is also suited to being screwed onto bottles. Such pumps are already being manufactured in large numbers. It is therefore also advantageous from a point of view of efficiency to apply them also in the invention.

In an embodiment of the storage holder according to the invention, the foam pump has an air passage, of which one end is located in an outer wall of the foam pump facing the reservoir, wherein the coupling piece is adapted to close off the air passage.

This allows, with the aid of the coupling piece, a pump to be coupled to the fluid reservoir which is also suitable for hand soap dispensers, wherein the fluid level is below that of the pump and the fluid reservoir is aerated, for instance because it is not flexible. The advantage is that this pump is manufactured in large series for application in hand soap dispensers. It is efficient and economical to also apply such a pump in the foam dispenser according to the invention.

According to a further aspect of the invention, the coupling piece is adapted to connect at least two parts of the foam pump to each other.

The coupling piece thus also performs the function of keeping together the foam pump. This allows a foam pump to be

used which is simpler, so that the costs of the foam pump will be lower.

According to still a further aspect of the invention, storage holder for placement in a foam dispenser, and
5 comprising a fluid reservoir having an opening, and a foam pump, comprising an air pump, a fluid pump, a closable supply to the air pump, a nozzle and a moveable operating part, wherein the foam pump dispenses a quantity of foam through the nozzle upon actuation of the operating part in a direction of
10 pumping, wherein the storage holder comprises a coupling piece, connected to the foam pump, with which the removable storage holder can be fastened in the foam dispenser, wherein the storage holder comprises a plug, connected to the fluid reservoir in the opening, and wherein the assembled foam pump
15 and coupling piece are coupled to the fluid reservoir by attachment to the plug.

The invention will now be explained in further detail with reference to the accompanying drawings.

20 Fig. 1 is a perspective view of an embodiment of the foam dispenser according to the invention.

Fig. 2 is a cross-sectional side view of the foam dispenser of Fig. 1.

Fig. 3 is a cross-section of the foam pump in the foam dispenser of Fig. 1.

25 Fig. 4 shows part of the reservoir, the coupling piece and the foam pump, prior to assembly into a reservoir according to the invention.

Fig. 5 is a side view of the foam dispenser of Fig. 1 in folded open condition.

30 Fig. 6 is a perspective view of the foam dispenser in folded open condition.

7a

Fig. 7 is a perspective view of a detail of the foam dispenser according to the invention, in which the coupling between the coupling piece and housing is to be seen.

5 Fig. 8 is a perspective rear view of the operating handle in a foam dispenser according to the invention.

Fig. 9 is a cross-sectional side view in which is to be seen how the handle is suspended in the housing.

The invention will be explained with reference to a soap foam dispenser 1. It will be clear that according to the invention, other foaming substances than soap can also be dispensed. The foam dispenser 1 according to the invention is for example suited for dispensing a foaming cleaning agent, cosmetics product, etcetera.

15 Fig. 1 shows an example of the soap foam dispenser 1. This comprises a housing 2 of which an operating handle 3 forms

a part. The housing 2 and the operating handle 3 are preferably made of plastic, e.g. POM, PA or ASA. Possibly, the operating handle 3 can be made of a different plastic from the housing 2, or have a different colour from the housing 2.

A window 4 is provided in the operating handle 3. Through the window 4, a view is provided of the contents of a reservoir, which is filled with liquid soap. Thanks to the window 4, one can see how full the reservoir still is. An embodiment with a window in the housing 2 is also possible.

Just visible in Fig. 1, is a nozzle 5 of a foam pump 6. In Fig. 1, one looks down aslant from the front, onto the dispenser 1. Normally, the soap foam dispenser 1 is attached by its rear side to the wall of, for example, a lavatory space. The user holds one or both hands underneath the nozzle 5 and presses the operating handle 3 with the palms of his hands, whereby a quantity of soap foam lands on his hand(s) by means of the nozzle 5.

Fig. 2 shows a cross-sectional side view of the dispenser 1. In use, a flat rear wall 7 of the dispenser 1 is attached to a wall. To this end, the rear wall 7 is provided with screw holes for example, or holes through which hooks in the wall can be stuck. In the housing 2, a removable storage holder with a soap reservoir 8 has been placed. The soap reservoir 8 comprises a flexible wall, schematically referred to by reference numeral 9. The foam pump 6 is connected to the wall 9 in a substantially airtight manner, as will be explained in further detail below. The wall 9 of the soap reservoir 8 preferably comes in the shape of a plastic bag.

Good properties of the bag are obtained when it is built up out of a laminate. An example of such a laminate is a laminate comprising of a layer of PE, a layer of PA, and another layer PE. PE has the advantage that it can be well

thermally welded, so that a stopper or plug can be welded into an opening in the bag. PA is a material that forms a good barrier against soap. The said materials are very flexible. It goes without saying that these materials are proposed merely by way of elucidating example. It is not necessary that the flexible wall 9 consist of a laminate. The wall 9 can also be formed by co-extrusion. Another choice of materials is also possible, as long as a good barrier against the contents of the reservoir 8 is provided.

In Fig. 2, the foam pump 6 can also be seen, which is connected to the flexible wall 9 in an airtight manner and thus forms one removable whole with the soap reservoir 8. The foam pump sucks up the liquid soap from the reservoir 8 through a short suction tube 10. Thanks to the short suction tube 10, it is also possible to use the storage holder in a dispenser in which the pump 6 lies above the bag, without the bag having to be completely filled upon delivery. The liquid pump of the foam pump 6 can pump air. It has, however, become apparent that immaculate execution of the first stroke of the foam pump 6 can be ensured by sucking fluid through the suction tube 10. In the foam pump 6, foam is formed by mixing with air, which is dispensed via the nozzle 5.

An important advantage of the shown apparatus lies in the use of the flexible wall 9 and the airtight connection to the pump 6. Due to the use of the flexible wall 9 no aeration of the reservoir 8 is necessary. Therefore, no air holes are needed in the wall 9, due to which no measures are necessary to prevent the fluid contents flowing from the reservoir 8. As more fluid is pumped up out of the reservoir 8, the flexible wall 9 collapses further. No fluid can reach the foam pump 6 from the reservoir 8 either, other than through the suction

tube 10. This is particularly important, because the foam pump 6 lies lower than the fluid in use.

In Fig. 3, a cross-section of the foam pump 6 is depicted, to illustrate the most important principles and parts of such a pump. The foam pump 6 is preferably of a type that is also used for hand soap dispensers in the shape of bottles. Such pumps are cheap and are produced in large quantities. An example of such a pump is known from US patent Nr. 6 053 364, so that the following will be confined through a description of the aspects of importance to the present invention.

The foam pump 6 is actuated by moving an operating part 11 in a downward direction, as depicted in Fig. 3. Foam leaves the pump 6 through the nozzle 5, which forms an integral part of part 11. Actuation of the operating part 11 leads to actuation of an air ring piston 12, which moves in an air chamber 13, and of a fluid piston 14, which moves through a fluid chamber 15. Thereby, air is expelled from the air chamber 13 and fluid from the fluid chamber 15 to a mixing chamber 16, through openings 17, for example in the shape of grooves (not visible in Fig. 3) in the fluid piston 14, between the air ring piston 12 and fluid piston 14 and a closable opening 18 between the fluid piston 14 and a central sealing element 19, respectively. Via one or more foam forming parts 20, situated between mixing chamber 16 and nozzle 5, foam leaves the mixing chamber 16. The foam forming parts 20 can for example be present in the form of perforated plates or meshes.

When the air ring piston 12 moves up to the initial position, an under pressure arises in the air chamber 13. Valves 21, here in the shape of holes which are covered by membranes, open as a consequence of this under pressure. Air is sucked in from outside, past the operating part 11, which

shows some clearance. The air is thus supplied from outside the reservoir 8 through an air supply, closable by the valves 21. Because the air is sucked in from outside, no air supply from the reservoir 8 is necessary.

Fig. 4 shows how the foam pump 6 is attached to the flexible wall 9 of the reservoir 8. The wall 9 is thermally welded to a plug 22 in an opening in the reservoir 8. Bonding is also possible in principle. The foam pump 6 is connected to a coupling piece 23, with which the storage holder, comprising the reservoir 8, the foam pump 6, the coupling piece 23 and the plug 22, can be attached to the housing 2.

Guidance edges, not shown, can ensure that the parts 6, 22, 23 are positioned at a correct angle around the longitudinal axis depicted by a dashed line, relative to each other. For example, a defined tightening moment can be adhered to when screwing the foam pump 6 to the coupling piece 23, to ensure that the foam pump 6 is aligned correctly relative to the rest of the storage holder and the housing 2.

In the embodiment shown in Fig. 4, the foam pump 6 is screwed to the coupling piece 23. This assembly is subsequently pushed tight onto the plug 22. It goes without saying that other ways of attachment are possible. Thus, it is also possible that the pump is attached by means of a snap or click connection to the coupling piece. An embodiment, in which the coupling piece is bonded to the plug or screwed onto it, is also conceivable. In these embodiments guidance means can also be applied to align the pump, coupling piece and plug at a correct angle relative to the longitudinal axis.

In the embodiment depicted in Fig. 4, the coupling piece 23 comprises a threaded neck 24 and a foam pump 6 comprises a matching thread 25, applied to the inside of a cap 26. This is an advantageous embodiment of the invention. Foam

pumps with such a thread 25 are produced in large quantities for screwing onto the threaded neck of the bottle of a hand soap dispenser. The foam pump 6 shown in Figure 3 is also a typical example of this. It is thereby possible to use the foam pump 6 both in soap dispensers according to the invention and in such hand soap dispensers, by which means advantages of scale are consequently achievable in production.

To be useful in such dispensers, which generally do not have a flexible wall and are used in a standing position, the shown foam pump 6 is provided with an air passage 28 located in an outer wall 27 of the air chamber 13, which emerges into the fluid reservoir, the bottle, at one end, and, at the other end, is, at least indirectly, in contact with the outside air. This serves to aerate the bottle. As mentioned above, this is not necessary for the invention, because use is made of a reservoir 8 with a flexible wall 9. The wall 9 collapses as the reservoir 8 empties. The air passage 28 is even bothersome, as it can also form a source of contamination of the pump and of the soap flowing through it. In hand soap dispensers it is also the cause of the fact that the dispenser can only be used standing up. In a hand soap dispenser with a bottle as a reservoir, the hole forms an open connection between the pump 6 and the contents of the bottle. In the shown dispenser, according to the invention, this is of less concern, because the short suction tube 10 is already clamped onto the plug 22, so that soap can only flow through the pump 6 through the tube 10. Contamination of the pump could, without further measures, however occur.

To be able to nevertheless use this pervasive type of foam pump 6, the coupling piece 23 is adapted to close off the air passage 28. At least a part of the inner surface of the coupling piece 23 abuts the outer wall 27 of the air chamber 13

to this end, in such a manner that the air passage 28 is closed off.

In the shown embodiment, the coupling piece 23 performs another important function, as it is adapted to connect the cap 26 to the rest of the pump 6, in this case the outer wall 27 of the air chamber 13. The coupling piece 23 therefor plays a role in connecting the parts of the foam pump 6. Upon screwing together the foam pump 6 and the coupling piece 23, a front edge 29 of the coupling piece 23 comes to rest against a supporting area 13, which forms part of the outer wall 27 of the air chamber 13, so that this outer wall 27 is pressed against the cap 26.

As can be seen in, amongst others, Fig. 2, the pump 6 mechanically contacts the handle 3 and is actuated by means of the handle 3, whereby the nozzle 5 moves in the direction of the reservoir 8. To prevent the entire pump 6 being pressed into the bag, and thus no foam being dispensed, the pump 6 is rigidly coupled to the housing 2, in a manner which will be further explained below.

The soap reservoir 8 has a further rectangular surrounding housing 31 around the flexible wall 9, for example made of stiff cardboard. This housing 31 eases the transport of the reservoir 8 and placement in the housing 2. An embodiment in which eyes, loops, or a seam with holes are provided on the bag, so that it can be suspended from the rear wall 7 on the inside is, however, also possible.

It is visible in Fig. 5 that the housing 2 actually comprises two parts, namely a carrier 32 and a hinging hood 33. An embodiment, in which the hood 33 can be completely detached, is also one of the possibilities. Such a modular build has the advantage that parts are easily replaceable, if they are damaged. Furthermore, different markets can be supplied by,

for example, different hoods. The handle 3 can possibly be replaceable, so that the housing 2 is not only suitable for the specific foam pump 6 depicted here.

The housing 2 is provided with a latching arrangement, not shown in further detail in Fig. 5, to hold the hood 33 in position during normal use. When the reservoir 8 is empty, the hood 33 is released and opened, and the entire storage holder, including the foam pump 6, is taken out and replaced by a full one.

Fig. 6 depicts a perspective view of the soap dispenser 1 in folded open condition. In this embodiment, in which the storage holder is provided with a surrounding housing 31 with a rigid wall, the storage holder is simply placed in a shallow tray, the so called box holder 34, in the carrier 32.

Also visible, is that the foam pump 6 is attached to the housing 2 by means of the coupling piece 23 upon placement of the storage holder. According to the invention, the coupling piece 23 is slid into an adapter 35 and locked in by two latches 36. By these means for securing and positioning the foam pump 6, it is, on the one hand, achieved that the foam pump is rigidly coupled to the housing 2 during use, so that the force exerted by the user through the handle 3 on the pump 6 can be resisted. The latches 36 prevent unintended release during use. On the other hand, the orientation of the foam pump 6 is thus also determined, so that the nozzle 5 points downwards and foam lands there where the user of the dispenser 1 expects it to.

Differently designed combinations of coupling piece 23 and adapter 35 are possible. A different type of locking of the coupling piece 23 is also possible. By using the coupling piece 23, different types of foam pump can be made suitable for

use in one type of housing 2. The coupling piece 23 forms part of the storage holder, and is thus included with it.

Attention is again drawn emphatically to the advantage of the modular build of the foam dispenser 1 according to the invention. One can manufacture different embodiments of the foam dispenser, which all comprise the same hood 33, foam pump 6 and other standard parts, but only differ in the design of the adapter 35, the coupling piece 23, or the latching of the coupling piece 23 in the adapter 35. This can be of importance, if different types of soap are available, for example for people with allergies or for use in a workshop or laboratory. It is then undesired that a reservoir 8 with the wrong contents is placed in the housing 2. With an adapter or latch of a specific shape, such an error is avoided. Only one specific type of storage holder can be placed in the housing 2.

In the embodiment according to Fig. 6, an opening 37 is present, defined by an edge 38, in the enclosing housing 31 of the storage holder. When the housing 2 is closed, a transparent cover 39 of the window 4 in the operating handle 3 moves in front of the opening 37. Thus a view is maintained of the contents of the reservoir 8, in order that it can be established timely that it is getting empty.

Preferably, the edge 38 is a perforated edge and the opening 37 is provided upon placement of the storage holder by tearing off a removable part of the enclosing housing 31 along the edge 38. In such an embodiment, the entire storage holder can be transported before use as a rectangular box, wherein the foam pump 6 lies in the box. If the housing 31 is then torn open along the edge 38, opening 37 comes into existence, from which the foam pump 6 and the coupling piece 23 can be pulled. The foam pump and the connection to the wall 9 of the soap bag are thus protected during transport by the enclosing housing

31. The storage holders are easily stackable due to the rectangular shape of the housing 31.

Fig. 7 provides a perspective view of the assembly of Fig. 4 just prior to placement of the storage holder in the box holder 34 which is part of the housing 2. A number of constructive measures which have been taken to position and secure the foam pump 6 relative to the housing 2 are also visible in this drawing. The coupling piece 23 thus has a cam 40, a rib 41 and a round protrusion 42. The coupling piece 23 is slid into the adapter 35, in this case integral with the box holder 34, to which the latches 36 are also attached. The latches 36 each have a recess 43 with which they engage the cams 40 of the coupling piece 23. Because the foam pump 6 is aligned relative to the coupling piece 23 and the coupling piece 23 relative to the housing 2, by means of the adapter 35, the foam pump cannot be placed lopsidedly in the housing 2. The foam thus always leaves the nozzle 5 in a downwardly directed flow.

In a preferred embodiment of the foam dispenser according to the invention, the latches 36 have a second function. In this embodiment the adapter 35 is provided with resilient means, not shown, which are supported by the coupling piece 23. The resilient means exert a force which would move the coupling piece 23 out of the adapter 35, if the latches 36 would not keep the coupling piece 23 under tension. If one wants to remove the storage holder, that is the assembly of reservoir 8 and foam pump 6, from the housing, then one moves the latches 36, so that the coupling piece 23 is pushed out of the adapter 35 by the resilient means. It is thus easier to handle. Changing of storage holders is thus considerably eased.

A further constructive measure, apart from that comprised in the adapter 35 and the coupling piece 23, to make the nozzle 5 point in the right direction will now be explained in further detail with reference to Fig. 8. Here, the operating handle 3 is shown in perspective, seen from behind. At this rear side, which is thus on the inside of the housing 2, two orientation ribs 44 have been provided which enclamp a nozzle 5 stuck through a hole 45. It is thereby guaranteed that not only does the nozzle 5 point in the right direction relative to the housing 2, but also that the nozzle 45 points in the right direction relative to the housing 2 and the foam pump 6. After placement of the storage holder in the housing 2, the nozzle 5 will, upon closing of the hood 33, stick through the hole 45 and be enclamped on both sides and be aligned by the ribs 44 which, for a better functioning, can possibly taper from above to below. Lopsidedness of the nozzle 5 is hereby corrected.

At its rear side, the hole 45 also has an edge 46. In the un hoped for event that the foam pump 6 should start to move brusquely during its lifetime, then with this edge 46 it can be taken care of that the operating part 11 of the foam pump 6 is returned to the initial position after actuation. When the handle 3 is returned to the initial position, the edge 46 will encounter a part, denoted by reference number 47 in Fig. 4, of the operating part 11 which is thus entrained in a direction opposite to the direction of actuation of the foam pump 6. The edge 46 of the handle 3 thus ensures that the handle 3 functions as a kind of carrier.

The handle 3 can be moved back by pulling it, but in a preferred embodiment of the invention, resilient means are fitted to point of suspension 48 of the handle 3, which ensure an automatic rebounding of the handle 3 after a stroke of the

pump. In Fig. 9, such a resilient element 49 is shown, which can for example consist of a bent strip of metal or elastic plastic. The resilient element 49 is attached to the point of suspension 48 at one end, for example by means of a screw. When the hood 33 is closed, the resilient element 49 is under tension, because the other end contacts a supporting area 50 of the box holder 34.

By means of a different choice of material or design of the resilient element 49, or by placing the point of suspension 48 or the supporting area 50 elsewhere, the maximum stroke and/or the maximum force transferable to the operating part 11 is set differently. The same effect can be achieved by moving the point of engagement of the handle 3 with the pump 6, for example by using a different adapter or a different coupling piece. Here again, the special advantage of the modular build of the foam dispenser 1 according to the invention becomes apparent. With a number of modules, a multitude of embodiments can be provided, which are each specifically adapted to a certain usage.

In Fig. 9, it can also be seen how the resilient force of the resilient element 49 is transferred to the nozzle 5, which, as mentioned, forms an integral part of the operating part 11, by means of the edge 46.

It will be apparent that the embodiment described above has been given purely by way of example and can vary within the scope of the claims. Thus, the foam dispenser according to the invention is not limited to the dispensing of soap foam. Other foaming substances can be dispensed also. The foam dispenser is also pre-eminently suited for use in different positions, because the bag of soap is closed in an airtight manner and fluid can only reach the pump in one manner. The foam dispenser need not necessarily therefor be

attached to a wall in the orientation here described, in order to function well.

CLAIMS

1. Storage holder for placement in a foam dispenser, and comprising a fluid reservoir having an opening, and a foam pump, comprising an air pump, a fluid pump, a closable supply to the air pump, a nozzle and a moveable operating part, wherein the foam pump dispenses a quantity of foam through the nozzle upon actuation of the operating part in a direction of pumping, wherein the storage holder comprises a coupling piece, connected to the foam pump, with which the removable storage holder can be fastened in the foam dispenser, wherein the storage holder comprises a plug, connected to the fluid reservoir in the opening, and wherein the assembled foam pump and coupling piece are coupled to the fluid reservoir by attachment to the plug.

2. Storage holder according to claim 1, wherein the fluid reservoir has a flexible wall, with which the foam pump is connected in a substantially airtight manner.

3. Storage holder according to claim 1 or 2, further provided with a surrounding housing with a rigid wall, suitable for suspension in the housing of a foam dispenser, wherein the wall of the surrounding housing comprises a detachable part for running the foam pump through.

4. Storage holder according to any one of claims 1-3, wherein the coupling piece comprises a threaded neck and the foam pump comprises a matching

thread, with which the foam pump is attached to the coupling piece.

5. Storage holder according to any one of
5 claims 1-4, wherein the foam pump has an air passage, of which one end is located in an outer wall of the foam pump facing the reservoir, wherein the coupling piece is adapted to close off the air passage.

10 6. Storage holder according to any one of claims 1-5, wherein the coupling piece is adapted to connect at least two parts of the foam pump to each other.

15 7. Foam dispenser, comprising a housing and, placed in the housing a removable storage holder, according to any one of claims 1-6, the removable storage holder being fastened to the housing with the coupling piece.

20 8. Foam dispenser according to claim 7, wherein the housing is provided with an adapter, in which the coupling piece is received, and wherein the coupling piece and the adapter are provided with one or more means
25 for fixing and positioning the foam pump.

9. Foam dispenser according to claim 8, wherein the adapter is provided with resilient means which are supported by the coupling piece and with one or
30 more latches which restrain the coupling piece in the adapter under tension.

10. Foam dispenser according to any one of claims 7-9, wherein the housing is provided with a handle, mechanically contacting the operating part of the foam pump, for transferring a force in the direction of
5 pumping.

11. Foam dispenser according to claim 10, wherein the handle is coupled to the operating part and the foam dispenser is further provided with resilient
10 means, supported by the housing and exerting a force opposed to the direction of pumping on the handle.

12. Foam dispenser according to claim 10 or 11, wherein a maximum displacement of the handle in the
15 direction of pumping and/or a maximum force transferable to the operating part can be set.

13. Foam dispenser according to any one of claims 10-12, wherein the nozzle is part of the operating
20 part and the handle is provided with means for aligning the nozzle.

14. Foam dispenser according to any one of claims 7-13, wherein the closable supply forms a
25 connection between the space outside the reservoir and the air pump.

1/7

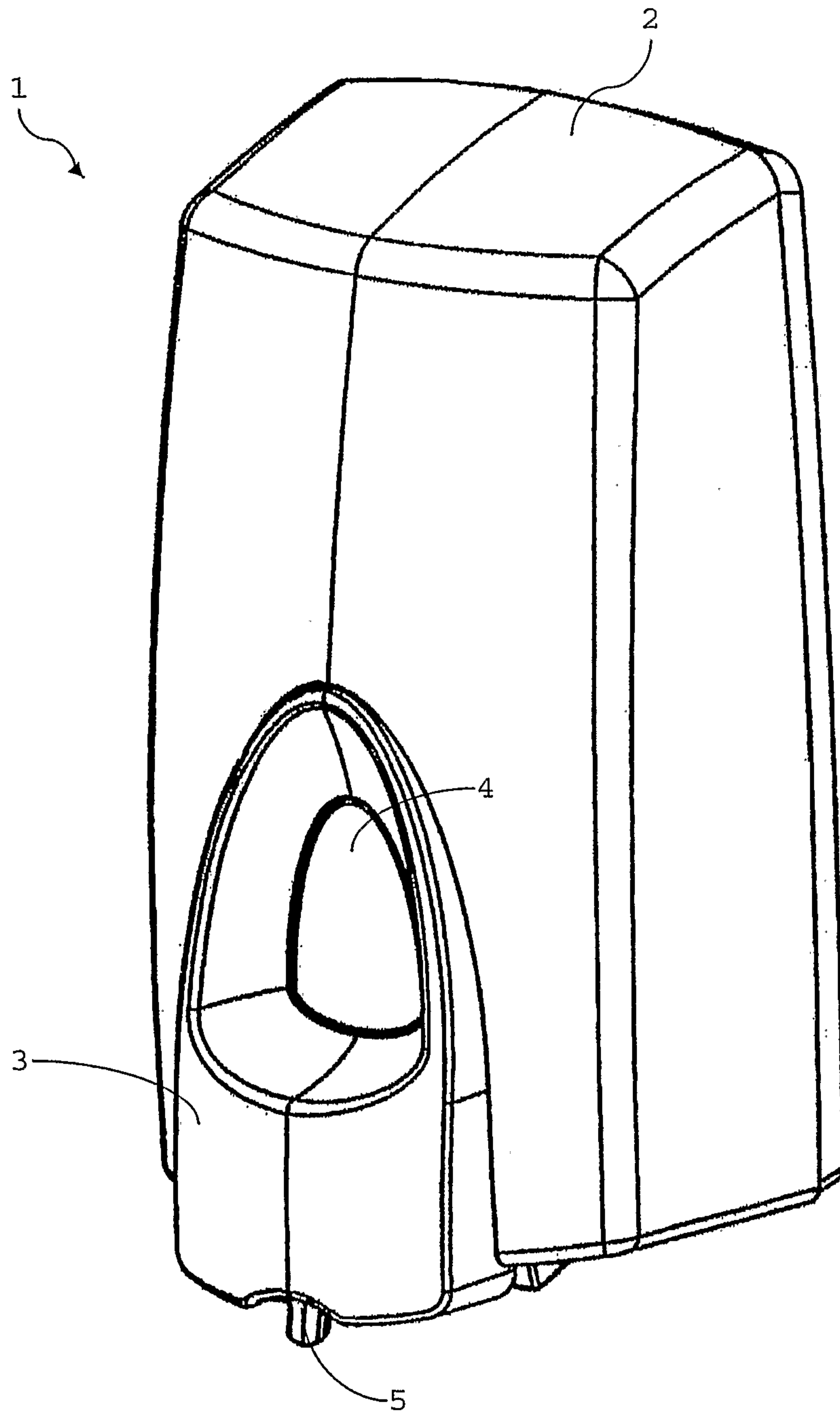

Fig. 1

2/7

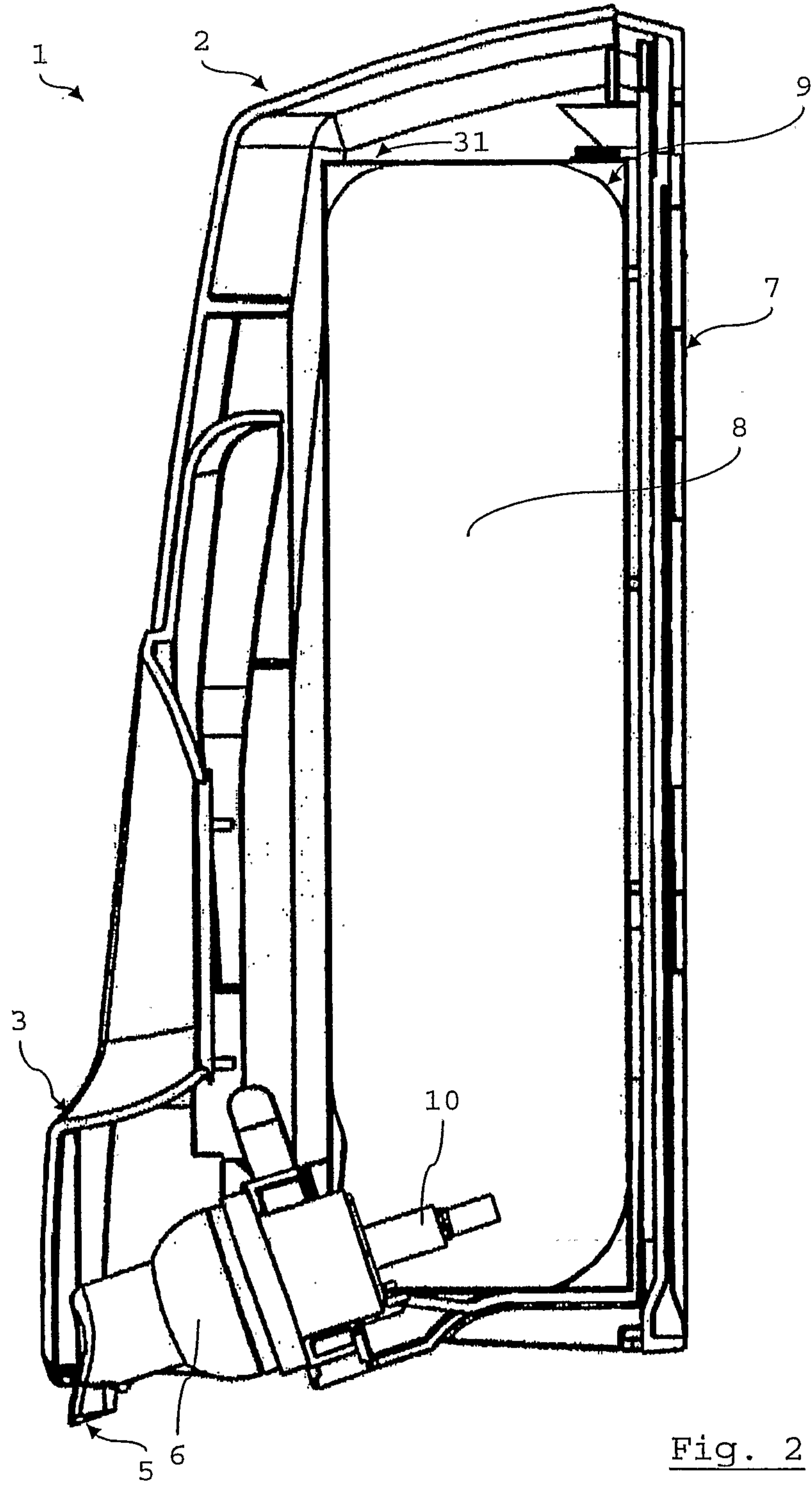

Fig. 2

3/7

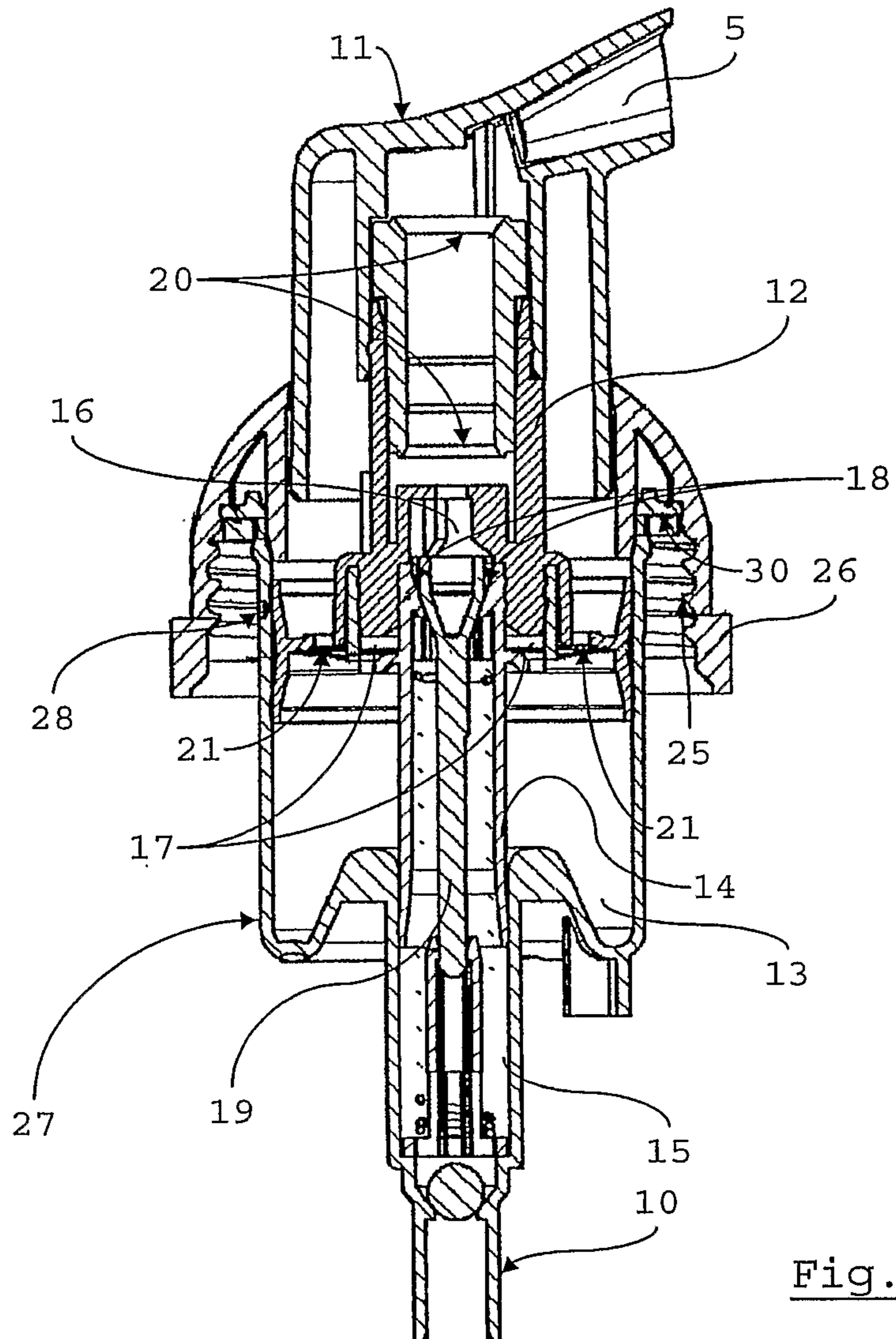

Fig. 3

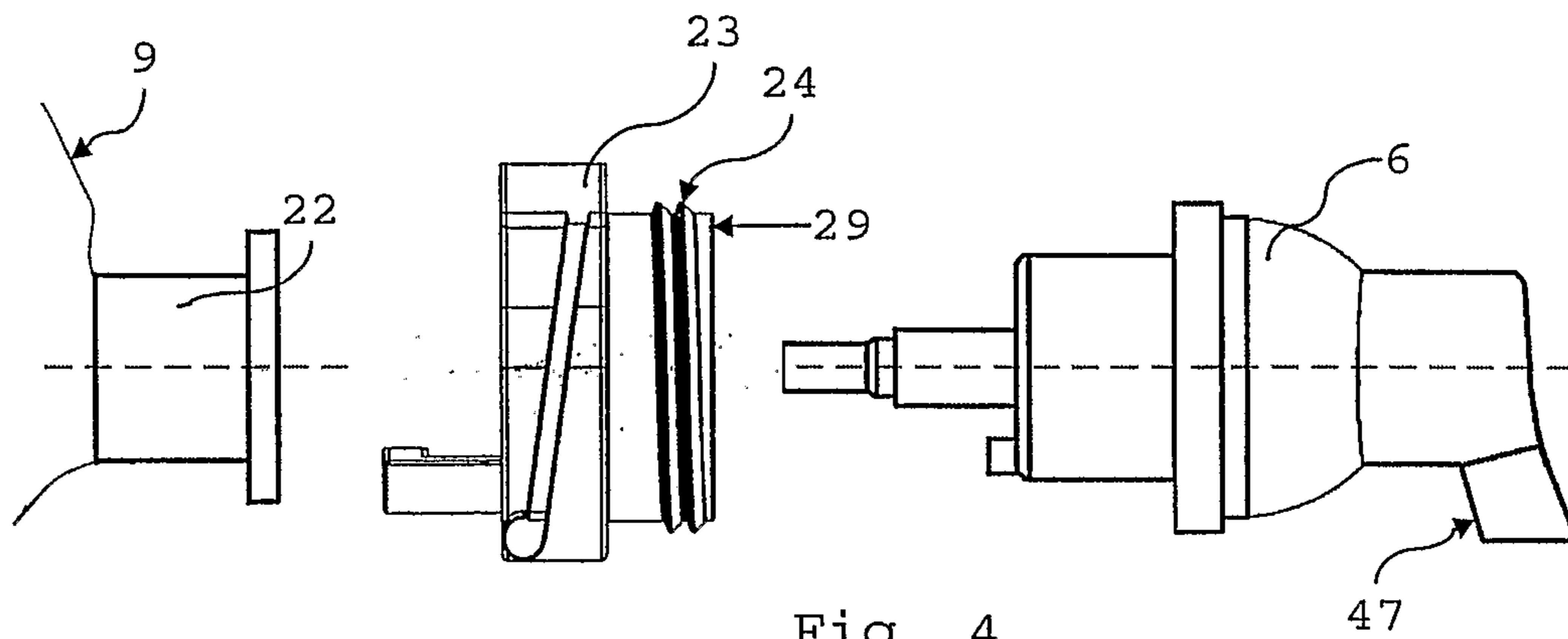

Fig. 4

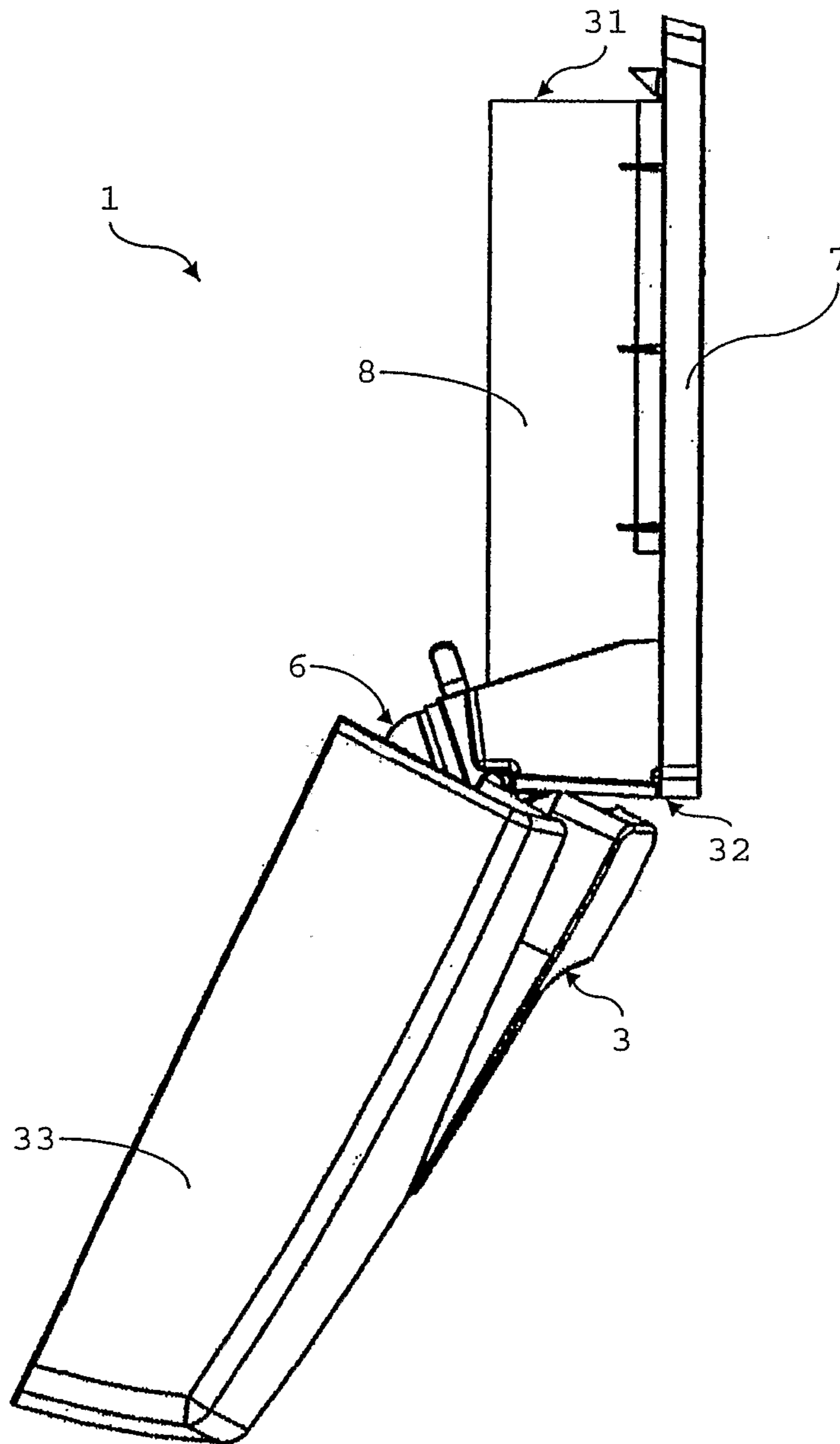

Fig. 5

5/7

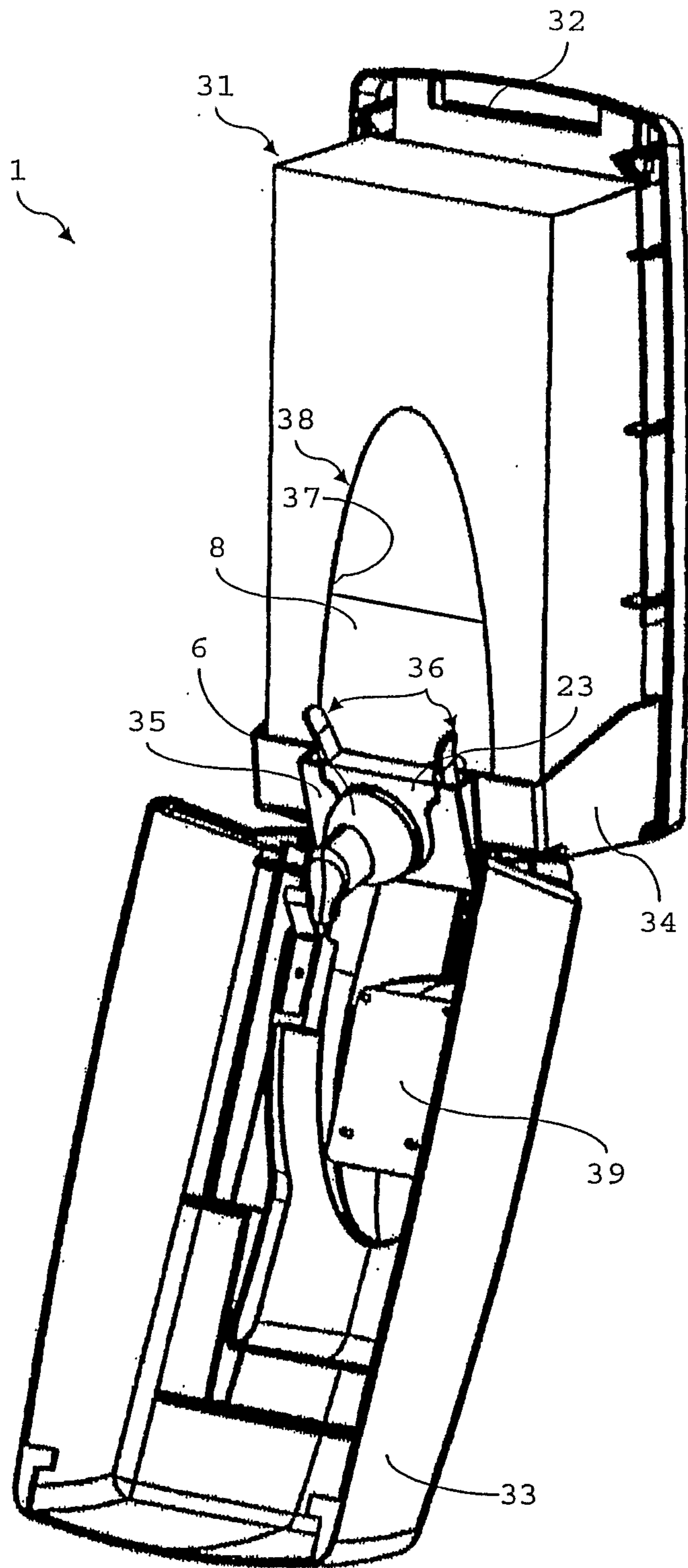

Fig. 6

6/7

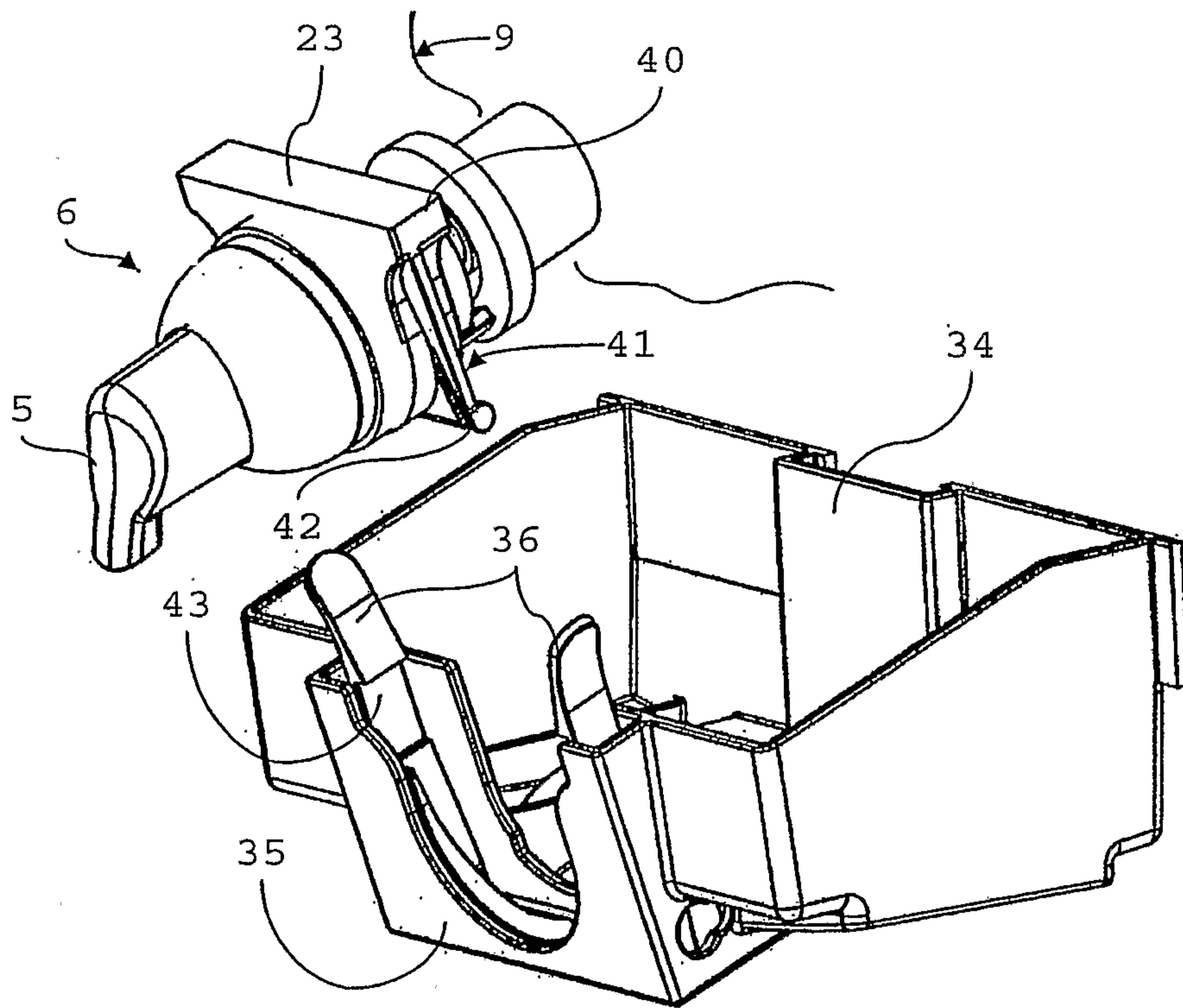

Fig. 7

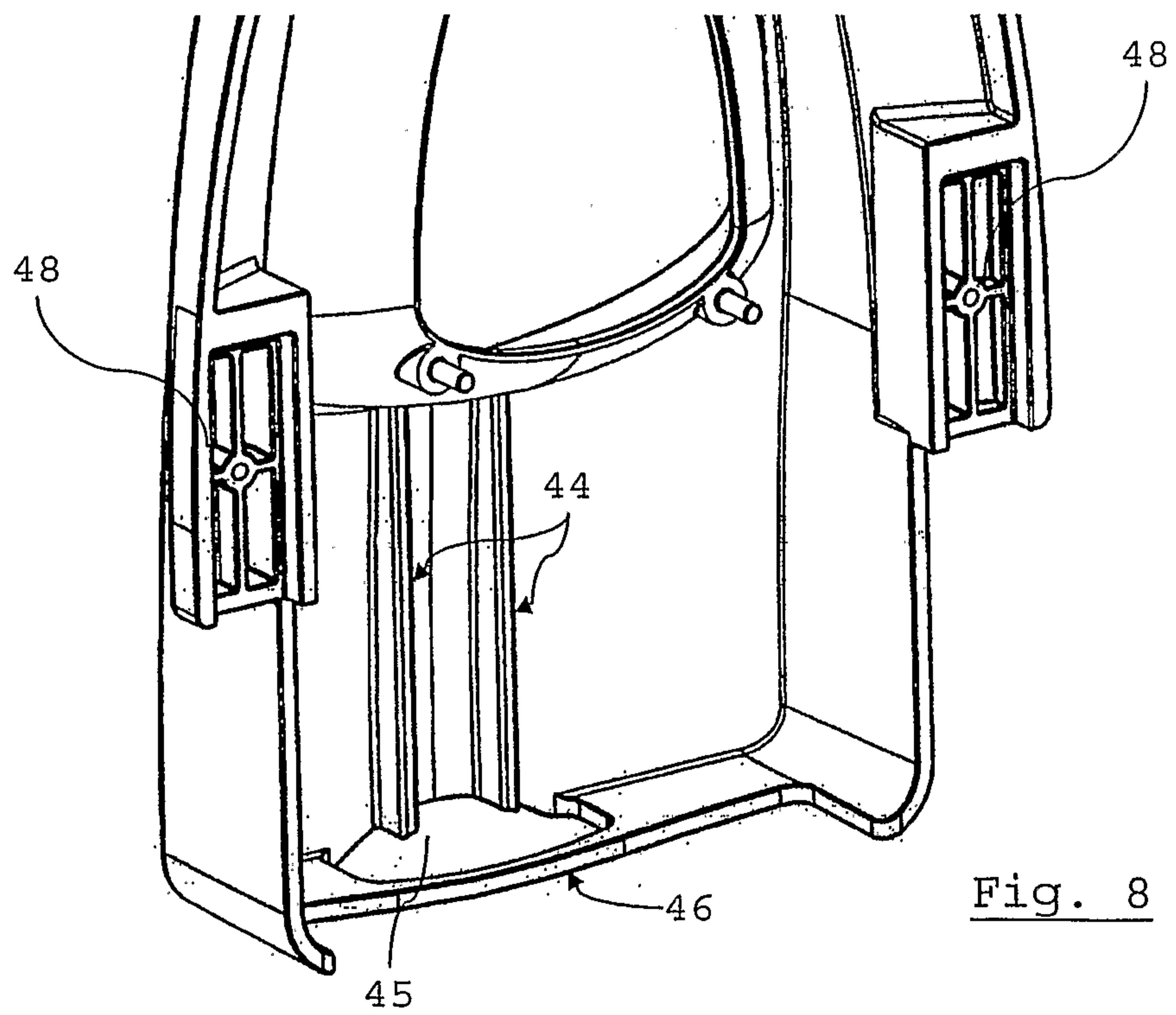

Fig. 8

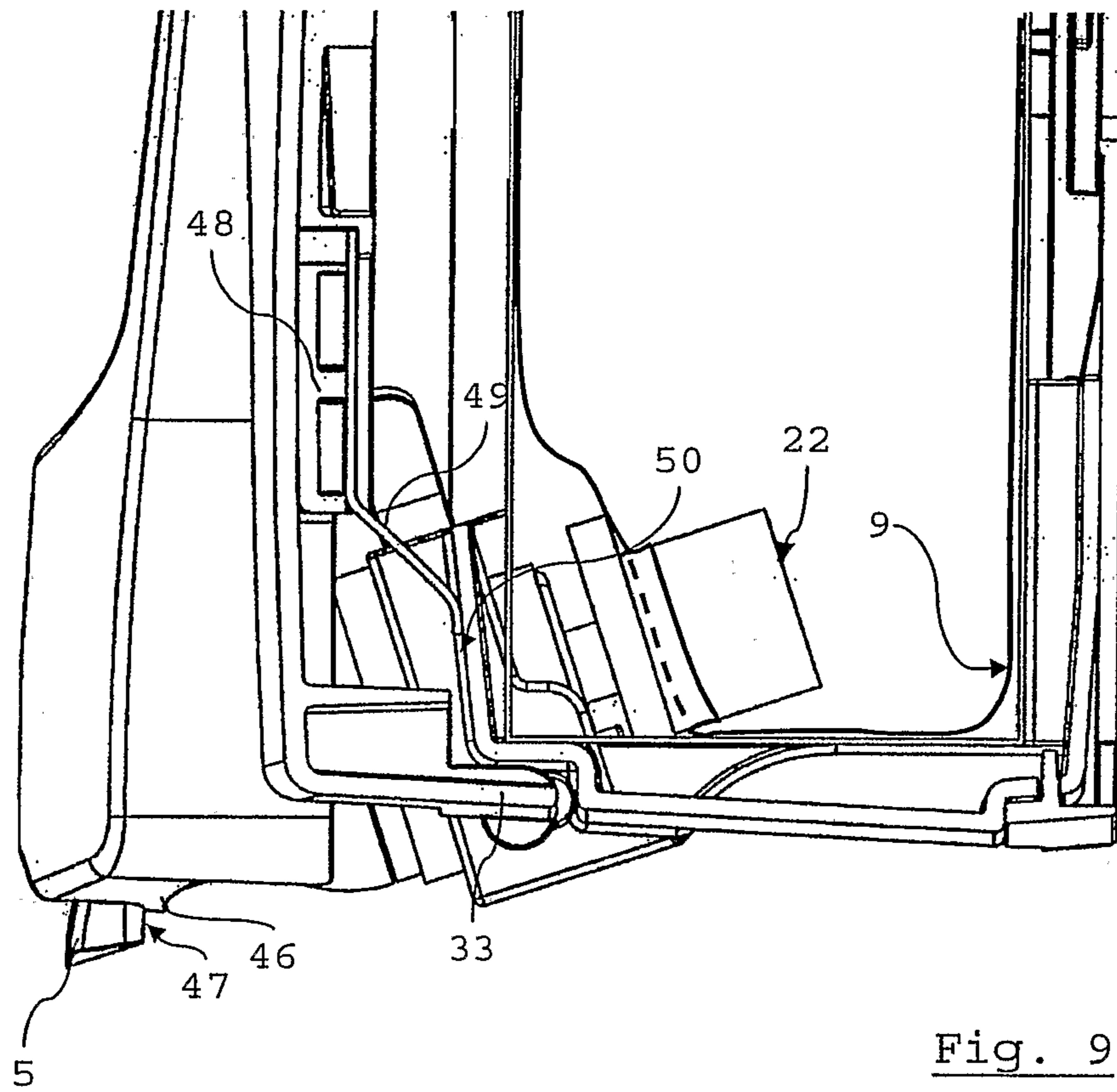

Fig. 9

