

G. C. SWEET.

Screw Plate.

No. 66,908.

Patented July 16 1867.

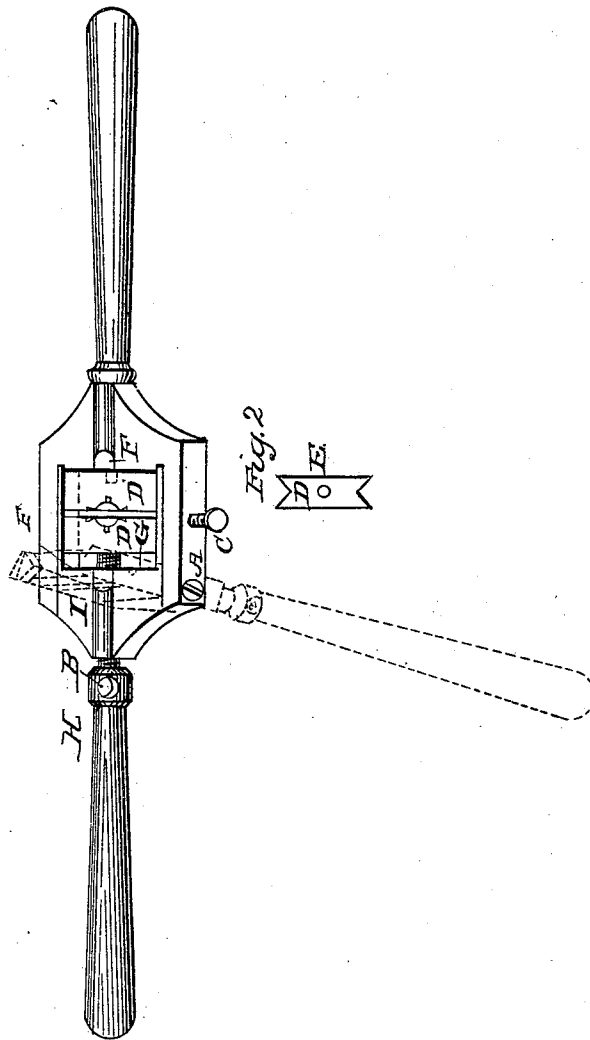

Witnesses
Albert Bellis.
Frank Douglas.

Inventor
George C Sweet

United States Patent Office.

GEORGE C. SWEET, OF NORWICH, CONNECTICUT, ASSIGNOR TO HIMSELF
AND FRANK DOUGLAS, OF SAME PLACE.

Letters Patent No. 66,908, dated July 16, 1867.

IMPROVED SCREW-PLATE.

The Schedule referred to in these Letters Patent and making part of the same.

TO ALL WHOM IT MAY CONCERN:

Be it known that I, GEORGE C. SWEET, of Norwich, county of New London, and State of Connecticut, have invented a new and improved Screw-Plate; and I do hereby declare that the following is a full, clear, and exact description thereof, reference being had to the accompanying drawings and to letters of reference marked thereon.

The nature of my invention consists in providing a screw-plate in which new dies may be easily fitted, and when in use said dies can be quickly changed or adjusted.

To enable others skilled in the art to make and use my invention, I will proceed to describe its construction and operation.

Figure 1 is a perspective view of the whole screw-plate, and also represents, by dotted lines, the part of the plate containing the dies tilted up for the reception or removal of said dies.

Figure 2 is a view of the end of die, showing the shape corresponding to plate, and also the hole E that locks the die in position for use.

D D are the dies; I the tilting-frame that holds them; H the screw-handle that sets the dies together when turned by a pin in hole B. The end of plate I, in which handle H is screwed, contains dies D D, and tilts on screw-pivots A A, as shown by dotted lines in fig. 1. The screws or pins A A, that form the pivots upon which the end I of the screw-plate is tilted, are screwed or driven into the half of the plate that contains the dies D D, and said pivots A A pass freely through the forked ends of the other half of screw-plate. I therefore designate the half of the screw-plate I, that contains the dies D D, and into which the screw-handle H is screwed, the tilting-frame. And said tilting-frame is pivoted to the other half of screw-plate by pivots A A, passing through the extreme ends that fork outside of tilting-frame, and thus the two halves of the screw-plate are held together by the pivots A A, and when tilted up in line it forms a whole screw-plate, with square hole in the centre that contains the dies D D. Die D, fig. 2, has a hole, B, and slides on to pin F, (as shown by dotted lines in fig. 1,) and locks it firmly in its place. Screw C may also be used for the same purpose when screwed into hole G of frame I.

The operation of changing dies is as follows: Die D is slipped off of pin F, and frame I is tilted down on screws A A, leaving dies D D free to be taken out or exchanged. When it is tilted back die D is slipped up on pin F to lock it firmly in its place. In heavy plates screw C should be used.

Claim.

What I claim as my invention, and desire to secure by Letters Patent, is—

A screw-plate made in two parts and pivoted together by pivots A A, for the purpose of tilting one-half of plate down for the removal or reception of dies, as herein specified.

GEORGE C. SWEET.

Witnesses:

ALBERT L. BOLLES,
FRANK DOUGLAS.