

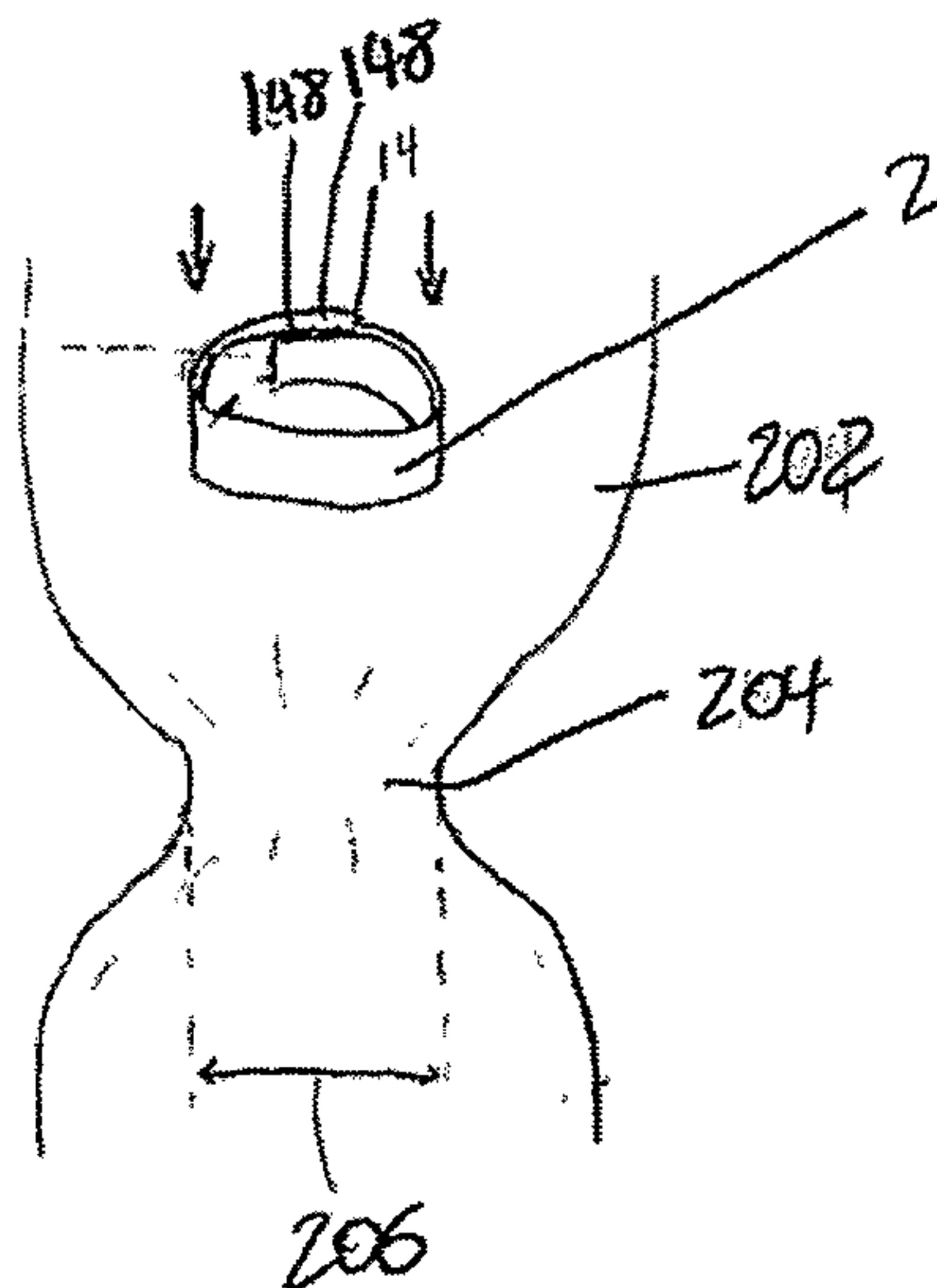

(86) Date de dépôt PCT/PCT Filing Date: 2003/12/20  
 (87) Date publication PCT/PCT Publication Date: 2004/07/15  
 (85) Entrée phase nationale/National Entry: 2005/06/08  
 (86) N° demande PCT/PCT Application No.: US 2003/041222  
 (87) N° publication PCT/PCT Publication No.: 2004/058106  
 (30) Priorité/Priority: 2002/12/20 (10/327,821) US

(51) Cl.Int.<sup>7</sup>/Int.Cl.<sup>7</sup> A61F 2/24  
 (71) Demandeur/Applicant:  
 ARBOR SURGICAL TECHNOLOGIES, INC., US  
 (72) Inventeurs/Inventors:  
 FOGARTY, THOMAS J., US;  
 DREWS, MICHAEL J., US;  
 HOLMGREN, NEIL, US;  
 MODESITT, D., BRUCE, US  
 (74) Agent: SMART & BIGGAR

(54) Titre : PROTHESE POUVANT ETRE IMPLANTEE BIOLOGIQUEMENT ET PROCEDE D'UTILISATION DE CELLE-CI  
 (54) Title: BIOLOGICALLY IMPLANTABLE PROSTHESIS AND METHODS OF USING THE SAME



(57) Abrégé/Abstract:

A biological implantable prosthesis (2) is disclosed. The prosthesis (2) can have a circumferentially expandable wall (4) with engagement elements (148) that enable the prosthesis (2) to engage a second prosthesis (68). The prosthesis (2) can be placed accurately into annulus (204) which has an initial annulus diameter (206). The prosthesis (2) can be used to expand the annulus (204) to an expanded annulus diameter (208).

## (12) INTERNATIONAL APPLICATION PUBLISHED UNDER THE PATENT COOPERATION TREATY (PCT)

(19) World Intellectual Property  
Organization  
International Bureau



(43) International Publication Date  
15 July 2004 (15.07.2004)

PCT

(10) International Publication Number  
**WO 2004/058106 A3**

- (51) International Patent Classification<sup>7</sup>: **A61F 2/24**
- (21) International Application Number:  
PCT/US2003/041222
- (22) International Filing Date:  
20 December 2003 (20.12.2003)
- (25) Filing Language: English
- (26) Publication Language: English
- (30) Priority Data:  
10/327,821 20 December 2002 (20.12.2002) US
- (71) Applicant (for all designated States except US): **ARBOR SURGICAL TECHNOLOGIES, INC.** [US/US]; 13844 Alton Parkway, Suite 140, Irvine, CA 92618 (US).
- (72) Inventors; and  
(75) Inventors/Applicants (for US only): **FOGARTY, Thomas, J.** [US/US]; 3270 Alpine Road, Portola Valley, CA 92028 (US). **DREWS, Michael, J.** [US/US]; 4524 U Street, Sacramento, CA 95817 (US). **HOLMGREN, Neil** [US/US]; 6211 N. Winthrop Ave. #605, Chicago IL 60660 (US). **MODESITT, D., Bruce** [US/US]; 120 Wingate Avenue, San Carlos, CA 94070 (US).
- (74) Agent: **LEVINE, David, A.**; P.O. Box 61180, Palo Alto, CA 94306-1180 (US).
- (81) Designated States (*national*): AE, AG, AL, AM, AT, AU, AZ, BA, BB, BG, BR, BW, BY, BZ, CA, CH, CN, CO, CR, CU, CZ, DE, DK, DM, DZ, EC, EE, EG, ES, FI, GB, GD, GE, GH, GM, HR, HU, ID, IL, IN, IS, JP, KE, KG, KP, KR, KZ, LC, LK, LR, LS, LT, LU, LV, MA, MD, MG, MK, MN, MW, MX, MZ, NI, NO, NZ, OM, PG, PH, PL, PT, RO, RU, SC, SD, SE, SG, SK, SL, SY, TJ, TM, TN, TR, TT, TZ, UA, UG, US, UZ, VC, VN, YU, ZA, ZM, ZW.
- (84) Designated States (*regional*): ARIPO patent (BW, GH, GM, KE, LS, MW, MZ, SD, SL, SZ, TZ, UG, ZM, ZW), Eurasian patent (AM, AZ, BY, KG, KZ, MD, RU, TJ, TM), European patent (AT, BE, BG, CH, CY, CZ, DE, DK, EE, ES, FI, FR, GB, GR, HU, IE, IT, LU, MC, NL, PT, RO, SE, SI, SK, TR), OAPI patent (BF, BJ, CF, CG, CI, CM, GA, GN, GQ, GW, ML, MR, NE, SN, TD, TG).
- Published:**
- with international search report
  - before the expiration of the time limit for amending the claims and to be republished in the event of receipt of amendments
- (88) Date of publication of the international search report:  
19 August 2004
- For two-letter codes and other abbreviations, refer to the "Guidance Notes on Codes and Abbreviations" appearing at the beginning of each regular issue of the PCT Gazette.*

(54) Title: BIOLOGICALLY IMPLANTABLE PROSTHESIS AND METHODS OF USING THE SAME

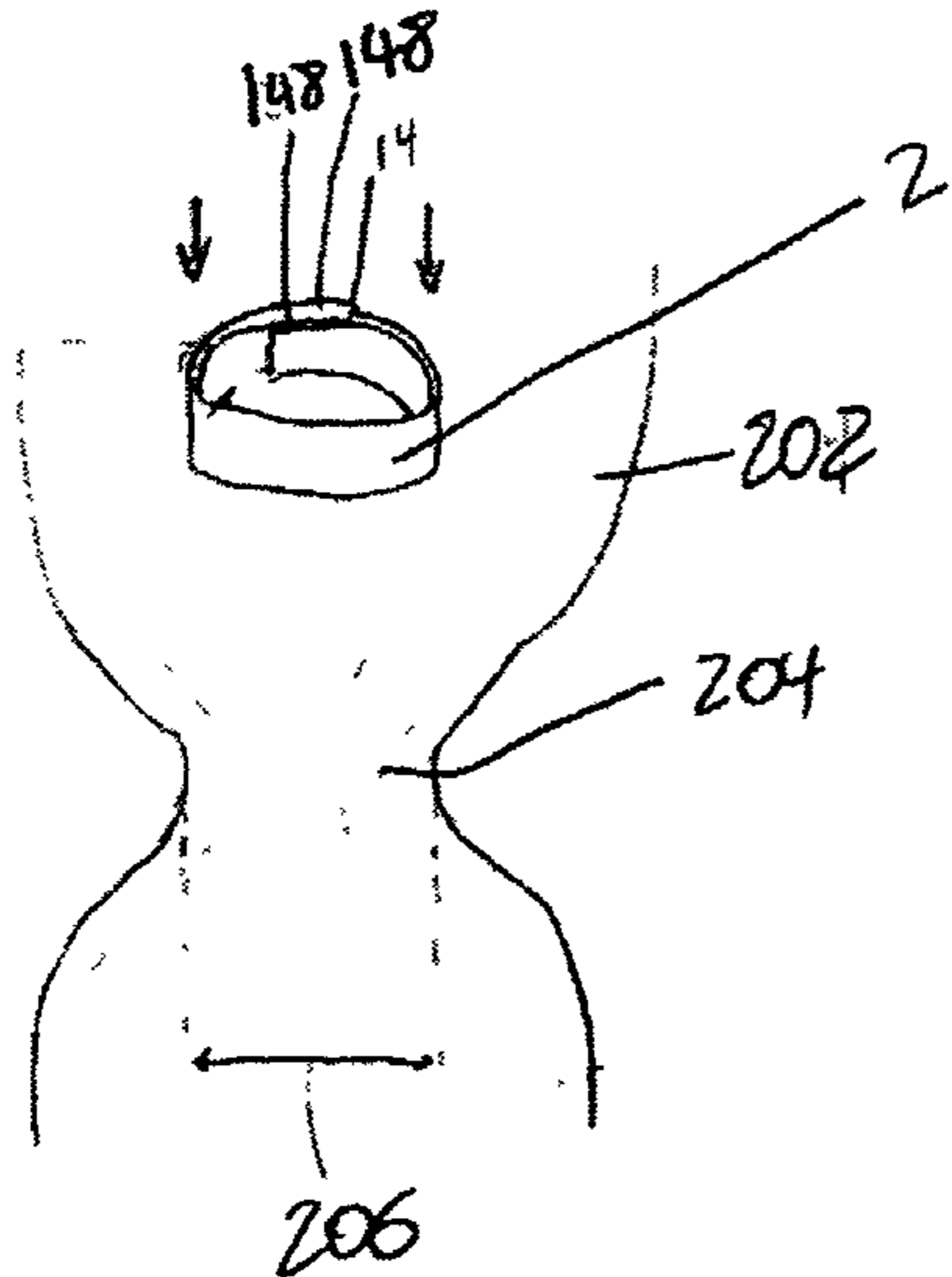

(57) Abstract: A biological implantable prosthesis (2) is disclosed. The prosthesis (2) can have a circumferentially expandable wall (4) with engagement elements (148) that enable the prosthesis (2) to engage a second prosthesis (68). The prosthesis (2) can be placed accurately into annulus (204) which has an initial annulus diameter (206). The prosthesis (2) can be used to expand the annulus (204) to an expanded annulus diameter (208).

WO 2004/058106 A3

1  
2  
3  
4  
5  
6  
7  
8  
9  
10  
11  
12  
13  
14  
15  
16  
17  
18  
19  
20  
21  
22  
23  
24  
25  
26  
27  
28  
29  
30  
31  
32  
33

## TITLE OF THE INVENTION

### **BIOLOGICALLY IMPLANTABLE PROSTHESIS AND METHODS OF USING THE SAME**

#### TECHNICAL FIELD

**[0001]** The present invention relates generally to a biologically implantable prosthesis, a heart valve assembly using the prosthesis, and methods of using the same within an annulus of the body.

#### BACKGROUND ART

**[0002]** Prosthetic heart valves can replace defective human valves in patients. Prosthetic valves commonly include sewing rings or suture cuffs that are attached to and extend around the outer circumference of the prosthetic valve orifice.

**[0003]** In a typical prosthetic valve implantation procedure, the heart is incised and the defective valve is removed leaving a surrounding area of locally tougher tissue. Known heart valve replacement techniques include individually passing sutures through the tough tissue to form an array of sutures. Free ends of the sutures are extended out of the thoracic cavity and laid, spaced apart, on the patient's body. The free ends of the sutures are then individually threaded through an edge around the circumference of the sewing ring. Once all sutures have been run through the ring, all the sutures are pulled up taught and the prosthetic valve is slid or "parachuted" down into place adjacent the tough tissue. Thereafter, the prosthetic valve is secured in place by traditional knot tying with the sutures.

**[0004]** The sewing ring is often made of a biocompatible fabric through which a needle and suture can pass. The prosthetic valves are typically sutured to a biological mass or annulus that is left when the surgeon removes the existing valve from the patient's heart. The sutures are tied snugly, thereby securing the sewing ring to the annulus and, in turn, the prosthetic valve to the heart.

**[0005]** Sewing rings can be tedious to secure to the valve orifice. Further, attaching the sewing ring to the annulus can be time consuming and cumbersome. The complexity of suturing provides a greater opportunity for mistakes and requires a patient to be on cardiopulmonary bypass for a lengthy period. It is also desirable to

1 provide as large of a lumen through the prosthetic valve as possible to improve  
2 hemodynamics. However, techniques for attaching the sewing ring to the orifice  
3 typically require the area of the valve lumen be reduced to accommodate an  
4 attachment mechanism. For example, the sewing ring is typically retained on top of  
5 the annulus, resulting in a lumen that is, at the largest, the size of the original lumen.  
6 **[0006]** A patient can also have a natural valve lumen that is detrimentally small. In  
7 these cases, the natural valve can be gusseted before the prosthetic valve is implanted.  
8 To gusset the natural valve, a longitudinal incision can be made along the wall of the  
9 lumen. The lumen can then be circumferentially expanded and the now-expanded  
10 incision can be covered with a patch graft or other membrane and stitched closed.  
11 **[0007]** U.S. Patent No. 4,743,253 to Magladry discloses a suture ring with a  
12 continuous compression ring. Magladry's ring is ductile, but provides a compressive,  
13 not expansive, force. In fact, the ring taught by Magladry is intended for placement  
14 over a heart valve and provides compression on the heart valve.  
15 **[0008]** U.S. Patent No. 6,217,610 to Carpentier et al. discloses an expandable  
16 annuloplasty ring. Carpentier et al. teach expanding the ring over the life of a patient  
17 by increasing the size of the ring by balloon dilatation. The ring is intended to  
18 remodel the shape of the valve annulus, not serve as a foundation to attach a second  
19 prosthesis and form a heart valve.  
20 **[0009]** U.S. Patent No. 5,984,959 to Robertson et al. discloses an expandable heart  
21 valve ring for attaching a synthetic valve thereto and a tool for attaching the ring to  
22 the synthetic valve. Robertson et al. teach the ring as having tabs that are used to  
23 attach to the second prosthesis by using a second device to engage the tabs.  
24 **[0010]** There is a need for a circumferentially expandable bio-prosthesis. There is  
25 also a need for a prosthesis and method that can expand an annulus and maintain an  
26 enlarged annulus circumference. Furthermore, there is a need for a minimally  
27 invasive heart valve replacement procedure. Also, there is a need for a prosthesis that  
28 can provide for the above and engagement with a second prosthesis, for example, the  
29 crown of a heart valve. Furthermore, there is a need for the above prosthesis that can  
30 self-engage a second prosthesis to improve implantation time.

31

32

## DISCLOSURE OF INVENTION

1 [0011] One embodiment of the disclosed prosthesis is a biologically implantable  
2 first prosthesis for a heart valve having a circumferentially expandable wall. The wall  
3 has a latitudinal cross-section perpendicular to the longitudinal axis, and a  
4 longitudinal cross-section parallel to the longitudinal axis. The prosthesis also has an  
5 engagement element configured to self-engage a second prosthesis.

6 [0012] The first prosthesis can also have a stop, where the stop prevents the wall  
7 from circumferentially decreasing. The first prosthesis can also have a fixturing  
8 device connector. The wall can also be corrugated. The wall can also have a turned  
9 lip on its leading edge. The first prosthesis can also be in an assembly where the first  
10 prosthesis can receive a second prosthesis, for example a crown.

11 [0013] Another embodiment of the prosthesis is a biologically implantable first  
12 prosthesis for a heart valve having a wall with a first edge and a second edge. The  
13 wall has a longitudinal axis at the center of the first prosthesis, and the first edge has  
14 an engagement element for engaging a second prosthesis. The engagement element is  
15 also turned toward the second edge.

16 [0014] The engagement element can be curved toward the second edge. The first  
17 edge can be the leading edge. The first prosthesis can also have a fixturing device  
18 connector that can be a port in the wall. The wall can also be corrugated. The first  
19 prosthesis can also be in an assembly with a second prosthesis connected to the  
20 engagement element. The second prosthesis can be a crown.

21 [0015] An embodiment of a method of implanting a heart valve in a valve annulus is  
22 attaching a first prosthesis to the valve annulus and attaching a second prosthesis to  
23 the first prosthesis. The first prosthesis has a circumferentially expandable wall. The  
24 wall has a longitudinal axis, and the wall has a latitudinal cross-section perpendicular  
25 to the longitudinal axis.

26 [0016] The first prosthesis can be a ring. The second prosthesis can be a crown.  
27 The wall of the first prosthesis can have a first terminal end and a second terminal  
28 end. Attaching the first prosthesis can include fixing the first prosthesis to a  
29 biological mass with a fixturing device. Attaching the first prosthesis can also include  
30 snap-fitting the second prosthesis to the first prosthesis.

31 [0017] Another embodiment of a method of implanting a heart valve in a valve  
32 annulus includes attaching a first prosthesis to the valve annulus and attaching a  
33 second prosthesis to the first prosthesis. The first prosthesis has a wall having a first

1 edge and a second edge. The wall also has a longitudinal axis. The first edge  
2 comprises an engagement element, and the engagement element is turned toward the  
3 second edge.

4 **[0018]** The engagement element can be turned away from the longitudinal axis.  
5 The first prosthesis can be a ring. The second prosthesis can be a crown. Attaching  
6 the crown can include snap-fitting the crown to the first prosthesis.

7 **[0019]** An embodiment of a method of increasing and maintaining the size of a  
8 biological valve annulus includes placing a circumferentially expandable first  
9 prosthesis in the annulus. The method also includes circumferentially expanding the  
10 first prosthesis, and circumferentially locking the first prosthesis.

11 **[0020]** Circumferentially expanding the first prosthesis can include increasing the  
12 radius of the annulus from about 0.1 mm (0.004 in.) to more than about 2.0 mm (0.08  
13 in.). The first prosthesis can also have an engagement element configured to receive a  
14 second prosthesis.

15

16

#### BRIEF DESCRIPTION OF THE DRAWINGS

17 **[0021]** Figure 1 is a bottom view of an embodiment of the prosthesis.

18 **[0022]** Figure 2 is a top perspective view of the embodiment of the prosthesis of  
19 Figure 1.

20 **[0023]** Figure 3 is a bottom view of another embodiment of the prosthesis.

21 **[0024]** Figure 4 is a top perspective view of the embodiment of the prosthesis of  
22 Figure 3.

23 **[0025]** Figure 5 is a bottom view of another embodiment of the prosthesis.

24 **[0026]** Figure 6 is a top perspective view of the embodiment of the prosthesis of  
25 Figure 5.

26 **[0027]** Figure 7 is a bottom view of another embodiment of the prosthesis with cut-  
27 away views of the collars.

28 **[0028]** Figure 8 is a top perspective view of the embodiment of the prosthesis of  
29 Figure 7 with cut-away views of the collars.

30 **[0029]** Figure 9 is a bottom view of another embodiment of the prosthesis with cut-  
31 away views of the collars.

32 **[0030]** Figure 10 is a top perspective view of the embodiment of the prosthesis of  
33 Figure 8 with cut-away views of the collars.

- 1 [0031] Figure 11 is a top perspective view of another embodiment of the prosthesis  
2 with magnets.
- 3 [0032] Figure 12 illustrates cross-section A-A of Figure 11.
- 4 [0033] Figure 13 is a top perspective view of another embodiment of the prosthesis  
5 with magnets.
- 6 [0034] Figure 14 illustrates cross-section B-B of Figure 13.
- 7 [0035] Figure 15 is a top perspective view of another embodiment of the prosthesis  
8 with magnets.
- 9 [0036] Figures 16-18 are top views of various deformable embodiments of the  
10 prosthesis in unexpanded states.
- 11 [0037] Figure 19 is a top view of the embodiment of the prosthesis of Figure 12 in  
12 an expanded state.
- 13 [0038] Figures 20-22 illustrate various embodiments of the fixturing device  
14 connectors.
- 15 [0039] Figures 23-25 illustrate various embodiments of the receiving elements.
- 16 [0040] Figures 26 and 27 are cut-away views of various embodiments of the  
17 receiving elements.
- 18 [0041] Figures 28-33 illustrate various embodiments of the protrusions.
- 19 [0042] Figure 34 illustrates the steering elements.
- 20 [0043] Figures 35-43 are cross-sections of various embodiments of the wall of the  
21 prosthesis.
- 22
- 23 [0044] Figure 44 illustrates an embodiment of the prosthesis of Figure 38.
- 24 [0045] Figures 45 and 46 illustrate cross-sections of the wall of the prosthesis with  
25 various embodiments of the covering.
- 26 [0046] Figures 47-52 illustrate various embodiments of the engagement element.
- 27 [0047] Figure 53 is a cut-away view of an embodiment of positioning the prosthesis  
28 in an annulus with a solid view of the prosthesis.
- 29 [0048] Figure 54 is a cut-away view of an embodiment of positioning the prosthesis  
30 in an annulus.
- 31 [0049] Figures 55 and 56 illustrate various embodiments of the protrusions and  
32 receiving elements when the prosthesis is not expanded.
- 33 [0050] Figure 57 is a cut-away view of an embodiment of expanding the prosthesis.

- 1 [0051] Figures 58 and 59 illustrate an embodiment of an expansion tool.
- 2 [0052] Figures 60 and 61 illustrate another embodiment of an expansion tool.
- 3 [0053] Figures 62 and 63 illustrate various embodiments of the protrusions and  
4 receiving elements when the prosthesis is expanded.
- 5 [0054] Figure 64 is a cut-away view of fixturing the prosthesis to a biological mass.
- 6 [0055] Figures 65-68 illustrate an embodiment of a method and assembly for  
7 fixturing the prosthesis to a biological mass.
- 8 [0056] Figure 69 is a cut-away view of positioning the second prosthesis onto the  
9 first prosthesis with a solid view of the second prosthesis.
- 10 [0057] Figure 70 is a cut-away view of attaching the second prosthesis to the first  
11 prosthesis.
- 12 [0058] Figures 71-77 are exploded views of various embodiments of attaching the  
13 second prosthesis to the first prosthesis.
- 14 [0059] Figure 78 is an exploded view of an embodiment of attaching the second  
15 prosthesis to an adapter and attaching the adapter to the first prosthesis.
- 16 [0060] Figures 79 and 80 illustrate cross-sections C-C and D-D, respectively, from  
17 Figure 78.
- 18 [0061] Figure 81 is a top view of an embodiment of the first prosthesis with the  
19 second prosthesis attached thereto.
- 20 [0062] Figures 82-84 illustrate an embodiment of a method of removing the second  
21 prosthesis from the first prosthesis.

22

23

## DETAILED DESCRIPTION

24

## AND INDUSTRIAL APPLICABILITY

- 25 [0063] Figures 1 and 2 illustrate an embodiment of a biologically implantable first  
26 prosthesis 2. The first prosthesis 2 can have a wall 4. The wall 4 can have material  
27 strength and dimensions known to one having ordinary skill in the art to make the first  
28 prosthesis resiliently expandable. The wall 4 can have an open form or spiral  
29 longitudinal cross-section, as shown in Figure 1. The longitudinal cross-section can  
30 be perpendicular to a central longitudinal axis 6.
- 31 [0064] The wall 4 can have a first terminal end 8 and a second terminal end 10.  
32 Each end 8 and 10 can be defined from a midpoint 12 of the wall 4 to a first terminus  
33 14 or a second terminus 16 of the wall 4 at the respective end 8 or 10. The wall 4 can



1 have an end difference length 18. The end difference length 18 can be the shortest  
2 angular length from the first terminus 14 to the second terminus 16. The wall 4 can  
3 also have a leading edge 20 and a trailing edge 22. The leading edge 20 and trailing  
4 edge 22 can be substantially perpendicular to the longitudinal axis 6. The first  
5 prosthesis 2 can have a circumference equivalent to a wall length 24 minus an end  
6 difference length 18. The wall 4 can have a wall height 25. The wall height can be  
7 from about 3.18 mm (0.125 in.) to about 12.7 mm 8.26 mm (0.500 in.), for example  
8 about (0.325 in.). The wall 4 can also be void of any attachment device with which to  
9 fix one end 8 or 10 of the wall 4 to the other end 8 or 10 of the wall 4. The wall 4 can  
10 made from stainless steel alloys, nickel titanium alloys (e.g., Nitinol), cobalt-chrome  
11 alloys (e.g., ELGILOY® from Elgin Specialty Metals, Elgin, IL; CONICHROME®  
12 from Carpenter Metals Corp., Wyomissing, PA), polymers such as polyester (e.g.,  
13 DACRON® from E. I. Du Pont de Nemours and Company, Wilmington, DE),  
14 polypropylene, polytetrafluoroethylene (PTFE), expanded PTFE (ePTFE), polyether  
15 ether ketone (PEEK), nylon, extruded collagen, silicone, radiopaque materials or  
16 combinations thereof. Examples of radiopaque materials are barium, sulfate,  
17 titanium, stainless steel, nickel-titanium alloys and gold.

18 **[0065]** Figures 3 and 4 illustrate an embodiment of the first prosthesis 2 that can be  
19 mechanically expandable. A first protrusion 26 and a second protrusion 28 at the first  
20 terminal end 8 can extend from the wall 4. The protrusions 26 and 28 can extend  
21 perpendicular to the wall 4 or perpendicular to the longitudinal axis 6. The  
22 protrusions 26 and 28 can be tabs, brads, extensions, balls, rods or a combination  
23 thereof. The protrusions can have a protrusion depth 30 sufficient to retain the wall 4.

24 **[0066]** The wall 4 can also have a first receiving element 32 and a second receiving  
25 element 34 at the second terminal end 10 that receive or engage the first protrusion 26  
26 and the second protrusion 28, respectively. The wall 4 can also have more or less  
27 (e.g., one or zero) receiving elements 32 or 34. The receiving elements 32 and 34 can  
28 be holes in the wall 4. The receiving elements 32 and 34 can also be divets, dimples,  
29 hooks, slots, or a combination thereof. The protrusions 26 and 28 and receiving  
30 elements 32 and 34 can act together as a stop, or an interference fit, to prevent the first  
31 prosthesis 2 from circumferentially extending or decreasing beyond desired limits.

32 **[0067]** Figures 5 and 6 illustrate an embodiment of the first prosthesis 2 that can  
33 have protrusions 26 and receiving elements 32 that can be dimples. The protrusions

1 26 and receiving elements 32 can be in a first row 36, a second row 38, and additional  
2 rows 40. The protrusions 26 can also be in a first column 42, a second column 44,  
3 and additional columns 46. The receiving elements 32 can have a receiving element  
4 depth 46 within the same range of sizes as the protrusion depth 36, above.

5 **[0068]** Figures 7 and 8 illustrate an embodiment of the first prosthesis 2 that can  
6 have the protrusions 26 and 28 extending from the first terminus 14 substantially at a  
7 tangent to the wall 4. The protrusions 26 and 28 can be rods 48 with balls 50 at the  
8 ends of the rods 48. The receiving elements 32 and 34 can extend from the second  
9 terminus 16 substantially at a tangent to the wall 4. The receiving elements 32 and 34  
10 can be collars 52 for receiving the balls 50. The wall 4 can have a longitudinal cross-  
11 section in the shape of a circular open curve, as shown in Figure 7. A circumferential  
12 gap 54 can exist between the first terminus 14 and the second terminus 16.

13 **[0069]** Figures 9 and 10 illustrate an embodiment of the first prosthesis 2 that can  
14 have different embodiments of protrusions 26 and 28 and receiving elements 32 and  
15 34. The first prosthesis 2 of Figures 9 and 10 can also have a wall angle 56 relative to  
16 the longitudinal axis 6 controlled by the dimensions of the protrusions 26 and 28 and  
17 receiving elements 32 and 34 and the locations of the protrusions 26 and 28 and  
18 receiving elements 32 and 34 on the wall 4. The wall angle 56 can be from about 10°  
19 to about 60°, more narrowly from about 20° to about 45°, for example about 25°. The  
20 protrusions 26 and 28 and the receiving elements 32 and 34 can be located along the  
21 trailing edge 22, the leading edge 20 or therebetween.

22 **[0070]** Figures 11 and 12 illustrate an embodiment of the first prosthesis 2 with the  
23 wall 4 having a bottom segment 58 and a top segment 60. The first prosthesis 2 can  
24 be deformably circumferentially expandable. The bottom segment 58 can have the  
25 wall angle 56 relative to the longitudinal axis 6. The angle between the bottom  
26 segment 58 and the top segment 60 can be a joint angle 62. The joint angle 62 can be  
27 from about 90° to about 180°, more narrowly from about 90° to about 160°, for  
28 example about 120°. The wall 4 can also have a first steering groove 64 that can  
29 extend over the length of the bottom segment 58. The wall 4 can also have a second  
30 steering groove 66 that can extend over a portion of the length of the bottom segment  
31 58. The grooves 64 and 66 can help angularly align, with respect to the longitudinal  
32 axis 6, a second prosthesis 68 that can be attached to the first prosthesis 2. The  
33 grooves 64 and 66 can also prevent the rotation of the first prosthesis 2 with respect to

1 the second prosthesis 68. The second groove 66 can also help to longitudinally align  
2 the second prosthesis 68.

3 [0071] The first prosthesis 2 can also have engagement elements, for example top  
4 magnets 70 in the top segment 60 and bottom magnets 72 in the bottom segment 58.  
5 The magnets 70 and 72 can have a magnet height 74, a magnet width 76 and a magnet  
6 length 78. The magnets 70 and 72 can be rare earth, high strength-type magnets. The  
7 magnets can be made from neodymium-iron-boron and can be encapsulated in a  
8 coating made from PTFE (e.g., TEFLON® (from E. I. Du Pont de Nemours and  
9 Company, Wilmington, DE), PEEK, a similarly inert and stable biocompatible  
10 polymer, or a combination thereof. A radiopaque material can also be added to the  
11 coating. The top and/or bottom magnets 70 and/or 72 can be customized to allow for  
12 only one angular orientation of the second prosthesis 68 by changing the polarity of  
13 one or an irregular number of magnets 70 and/or 72 (e.g., positive) to be different  
14 from the polarity of the remaining magnets 70 and/or 72 (e.g., negative).

15 [0072] In one example, 24 magnets 70 can be evenly distributed around the  
16 circumference of the first prosthesis 2. The magnet heights 74 can be about 3.175  
17 mm (0.125 in.). The magnet widths 76 can be about 3.175 mm (0.125 in.). The  
18 magnet lengths 78 can be about 1.59 mm (0.0625 in.).

19 [0073] Figures 13 and 14 illustrate an embodiment of the first prosthesis 2 similar to  
20 the embodiment illustrated in Figures 11 and 12. The present embodiment of the first  
21 prosthesis 2 can have a cloth sewing surface 80. The magnets 70 can be square or  
22 rectangular in cross-section (as shown in Figures 11 and 12) or oval or circular in  
23 cross-section (as shown in Figures 13 and 14). The wall 4 can also be multiple  
24 segments 58 and 60, as shown in Figures 11 and 12, or a single segment, as shown in  
25 Figures 13 and 14.

26 [0074] Figure 15 illustrates an embodiment of the first prosthesis 2 similar to the  
27 embodiment illustrated in Figures 11 and 12. The first prosthesis 2 in the present  
28 embodiment can also be mechanically and/or resiliently circumferentially expandable.

29 [0075] Figures 16-18 illustrate deformable embodiments of the first prosthesis 2. In  
30 an unexpanded state, the first prosthesis 2 can have an unexpanded diameter 82. The  
31 embodiment of the first prosthesis 2 in Figure 16 can have a smooth wall 4, thereby  
32 relying on hoop strain to expand. In Figure 17, the embodiment can have an  
33 accordianed wall 4 with multiple pleats or folds 84. The folds 84 can open or unfold

1 to maximize circumferential expansion of the wall 4 during use. The embodiment of  
2 the first prosthesis 2 in Figure 18 can have a single large fold 84 for the same purpose  
3 as the folds 84 shown in Figure 17. Figure 19 illustrates a deformable embodiment of  
4 the first prosthesis 2 in an expanded state. A radial force, as shown by arrows,  
5 directed away from the longitudinal axis 6 can expand the first prosthesis 2 to an  
6 expanded diameter 86. Materials and dimensions of the first prosthesis 2 can be  
7 selected by one having ordinary skill in the art to permit the ratio of the unexpanded  
8 diameter 82 to the expanded diameter 86 to be from about 0% to about 50%, more  
9 narrowly from about 5% to about 20%, yet more narrowly from about 9% to about  
10 12%, for example about 9.5%.

11 **[0076]** Figure 20 illustrates a length of the wall 4 that can have a first fixturing  
12 device connector 88 and a second fixturing device connector 90. The fixturing device  
13 connectors 88 and 90 can be ports or holes in the wall 4. The fixturing device  
14 connectors 88 and 90 can be ovular and can have a fixturing device connector height  
15 92 and a fixturing device connector length 94. The fixturing device connector height  
16 92 can be from about 0.51 mm (0.020 in.) to about 3.18 mm (0.125 in.), more  
17 narrowly from about 1.0 mm (0.040 in.) to about 1.5 mm (0.060 in.), for example  
18 about 1.3 mm (0.050 in).

19 **[0077]** Figure 21 illustrates a length of the wall 4 that can have first, second, and  
20 additional fixturing device connectors 88, 90 and 96. The fixturing device connectors  
21 88, 90 and 96 can be circular in shape. Figure 22 illustrates a length of the wall 4 that  
22 can have the fixturing device connectors 88, 90 and 96 attached to the leading and  
23 trailing edges 20 and 22. The fixturing device connectors 88, 90 and 96 can be made  
24 from fabric or metal, for example polymers such as polyester (e.g., DACRON® from  
25 E. I. Du Pont de Nemours and Company, Wilmington, DE), polypropylene, PTFE,  
26 ePTFE, nylon, extruded collagen, silicone, stainless steel alloys, nickel-titanium  
27 alloys (e.g., Nitinol), cobalt-chrome alloys (e.g., ELGILOY® from Elgin Specialty  
28 Metals, Elgin, IL, CONICHROME® from Carpenter Metals Corp., Wyomissing, PA)  
29 or combinations thereof. Various shaped and configured fixturing device  
30 connectors 88, 90 and 96 can be on the same wall 4.

31 **[0078]** Figure 23 illustrates a length of the wall 4 that can have the receiving  
32 elements 32 and 34. The receiving elements 32 and 34 can be ports or holes in the  
33 wall 4. The receiving elements 32 and 34 and the fixturing device connectors 88, 90

1 and 96 can be the same element. The receiving elements 32 and 34 can have a first  
2 setting position 98 and a first neck 100 at one end of the first setting position 98. The  
3 first setting position 98 can have a setting position length 102 from about 4 mm (0.2  
4 in.) to about 10 mm (0.4 in.), for example about 6.3 mm (0.25 in.). The first neck 100  
5 can have a neck width 104. The first neck 100 can be at a first end of a second setting  
6 position 106. The receiving elements 32 and 34 can have more or less than two  
7 setting positions 98 and 106 (e.g., one or zero). At a second end of the second setting  
8 position 106, the second setting position 106 can have a second neck 108. The second  
9 neck 108 can be at a first end of a final stop position 110. The final stop position 110  
10 can have a final stop length 112.

11 **[0079]** The first and second setting positions 98 and 106 can lead to the first and  
12 second necks 100 and 108, respectively, with a ramp angle 114. The stop position  
13 110 and the second setting position 106 can lead to the second 108 and first necks  
14 100, respectively, with a stop angle 116.

15 **[0080]** Figure 24 illustrates narrowing oval or teardrop-shaped receiving elements  
16 32 and 34. Figure 25 illustrates rectangular receiving elements 32 and 34.

17 **[0081]** Figure 26 illustrates the receiving element 32 that can be in the shape of a  
18 collar or sleeve. The receiving element 32 can be attached by a connection zone 118  
19 to a rod (not shown) extending from the wall 4 or to the wall 4 itself. The receiving  
20 element 32 can have first wedges 120 and second wedges 122. The length between  
21 the closest point of the first wedges 120 or of the second wedges 122 can be the neck  
22 width 104. The wedges 120 and 122 can revolve around the entire receiving element  
23 32, thereby forming a single, circular first wedge 120 and a single, circular second  
24 wedge 122 (when seen in three-dimensions).

25 **[0082]** A receiving element shaftway 124 can be open at one end of the receiving  
26 element 32. The receiving element 32 can have a first narrowing 126 near the  
27 connection zone 118 and a second narrowing 128 near the receiving element shaftway  
28 124. Figure 27 illustrates the receiving element 32 that can have the wedges 120 and  
29 122 shaped as scales or stop tabs.

30 **[0083]** A length of the wall 4 that can have protrusions 26 and 28 is illustrated in  
31 Figure 28. The protrusions 26 and 28, shown alone in various embodiments in  
32 Figures 29 and 25, can be made from an extension 130 and a cuff 132. The extension  
33 130 can be shaped cylindrically or, as shown in Figure 30, as a shaft with a triangular

1 cross-section. The extension 130 can have an extension height 134 and an extension  
2 width 136. The extension height 134 can be from about 0.51 mm (0.020 in.) to about  
3 2.54 mm (0.100 in.), for example about 1.3 mm (0.050 in.). The final stop length 112  
4 can be from about the extension width 136 to about 10 mm (0.4 in.), for example  
5 about 6.3 mm (0.25 in.).

6 **[0084]** The cuff 132 can be shaped as a circle or a square and can be substantially  
7 flat in depth. The cuff 132 can have a cuff height 138 and a cuff width 140. The cuff  
8 height 138 can be from about the fixturing device connector height 92 to about 5.08  
9 mm (0.200 in.), for example about 2.0 mm (0.080 in.). The cuff width 140 can be  
10 within the range for the cuff height 138, above.

11 **[0085]** Figure 31 illustrates a length of the wall 4 having the protrusions 26 and 28  
12 formed from tabs cut out of the wall 4. Cut holes 142 can exist in the wall 4 where  
13 the material in the protrusions 26 and 28 was located in the wall 4 before being cut  
14 out.

15 **[0086]** Figure 32 illustrates a length of the wall 4 that can have a first set and a  
16 second set of protrusions 26 and 28 extending from the wall 4. The wall 4 can have a  
17 wall radius of curvature 144. The protrusions 26 and 28 can have protrusion radii of  
18 curvature 146. The protrusion radii of curvature 146 can be from about the wall  
19 radius of curvature 144 to infinity.

20 **[0087]** Figure 33 illustrates a length of the wall 4 that can have an engagement  
21 element 148. The engagement element 148 can be shaped as a lip and wrapped  
22 around the protrusion 26. The engagement element 148 can enable the first prosthesis  
23 2 to self-engage the second prosthesis 68. For example, the engagement element 148  
24 can snap-fit to the second prosthesis 68.

25 **[0088]** Figure 34 illustrates the first terminal end 8 and the second terminal end 10.  
26 The second terminal end 10 can have a first guide 150 and a second guide 152 that  
27 can wrap around the leading edge 20 and the trailing edge 22, respectively, of the first  
28 terminal end 8. The first terminal end 8 can slide angularly, with respect to the  
29 longitudinal axis 6, within the guides 150 and 152. The guides 150 and 152 can also  
30 minimize the risk of the first terminal end 8 moving too far away from or becoming  
31 misaligned from the second terminal end 10.

32 **[0089]** Figures 35-43 illustrate embodiments of the first prosthesis 2 at a latitudinal  
33 cross-section. The latitudinal cross-section can be a cross-section parallel with the

1 longitudinal axis 6. Figure 35 illustrates an embodiment with the wall 4 having a  
2 corrugated latitudinal cross-section. Figure 36 illustrates an embodiment with the  
3 wall 4 having a straight latitudinal cross-section, parallel with the longitudinal axis 6.

4 **[0090]** Figure 37 illustrates an embodiment having the trailing edge 22 angled  
5 toward the longitudinal axis 6 at the wall angle 56. Figure 38 illustrates an  
6 embodiment having the trailing edge 22 angled away from the longitudinal axis 6 at  
7 the wall angle 56.

8 **[0091]** Figure 39 illustrates an embodiment having a wall 4 convex toward the  
9 longitudinal axis 6. The wall 4 can be straight or have a lateral convex radius of  
10 curvature 154. Figure 40 illustrates an embodiment having a wall 4 concave toward  
11 the longitudinal axis 6. The wall 4 can have a lateral concave radius of curvature 156  
12 within the same range as the lateral convex radius of curvature 154.

13 **[0092]** Figure 41 illustrates an embodiment having a wall 4 with a top segment 60, a  
14 middle segment 158 and a bottom segment 58. The top segment 60 and leading edge  
15 20 can be angled away from the longitudinal axis 6. The bottom segment 58 and  
16 trailing edge 22 can be angled away from the longitudinal axis 6. The middle  
17 segment 158 can remain parallel to the longitudinal axis 6.

18 **[0093]** Figure 42 illustrates an embodiment having the top segment 60 and the  
19 leading edge 20 that can be angled toward the longitudinal axis 6. The bottom  
20 segment 58 and trailing edge 22 can also be angled toward the longitudinal axis 6.  
21 The middle segment 158 can remain parallel to the longitudinal axis 6.

22 **[0094]** Figures 43 and 44 illustrate an embodiment of the wall 4 that can have a  
23 bottom segment 58 that can extend from the wall 4 at a retainer angle 160 with respect  
24 to the longitudinal axis 6 from about 0° to about 90°, more narrowly from about 10°  
25 to about 50°, for example about 30°. The bottom segment 58 can also have cuts 162,  
26 shown in Figure 44. The cuts 162 can minimize stresses when the bottom segment 58  
27 fans away from the middle segment 158. The bottom segment 58 can also act as a  
28 retention element, extending beyond the typical trailing edge 22 and stabilizing the  
29 first prosthesis 2 after the first prosthesis 2 is implanted.

30 **[0095]** Figure 45 illustrates a cross-section of the wall 4 that can have a fabric  
31 covering 164, for example polyester (e.g., DACRON® from E. I. du Pont de Nemours  
32 and Company, Wilmington, DE), polypropylene, PTFE, ePTFE, nylon, extruded  
33 collagen, silicone or combinations thereof. The fabric can be attached to the wall 4 at

1 a first attachment point 166 and a second attachment point 168. The bare area of the  
2 wall between the attachment points 166 and 168 can be the engagement surface 170.  
3 The second prosthesis 68 can engage the first prosthesis 2 at the engagement surface  
4 170.

5 [0096] Figure 46 illustrates a cross-section of the wall 4 covered entirely by the  
6 covering 164. The second prosthesis 68 can also engage the first prosthesis 2 at the  
7 engagement surface 170 covered by the covering 164.

8 [0097] Figure 47 illustrates a length of wall 4 with the engagement element 148,  
9 shaped as an open lip, on the leading edge 20. The engagement element 148 can be  
10 turned toward the longitudinal axis 6 and toward the trailing edge 22. Figure 48  
11 illustrates the engagement element 148 turned away from the longitudinal axis 6 and  
12 toward the trailing edge 22.

13 [0098] Figures 49 and 50 illustrate an embodiment of the first prosthesis 2 that can  
14 have a first length 172, a second length 174 and a third length 176. The lengths 172,  
15 174 and 176 can be separated by cuts 162 in the wall 4. The engagement element 148  
16 on the first length 172 and third length 176 can turn toward the longitudinal axis 6.  
17 The top and middle segments 60 and 158 of the first length 172 and the third length  
18 176 can be bent away from the bottom segment 58 as shown by the arrows in Figure  
19 50. The top and middle segments 60 and 158 of the second length 174 can be  
20 similarly bent but in the opposite direction to the top and middle segments 60 and 158  
21 of the first and third lengths 172 and 176. The engagement element 148 on the  
22 second length 174 can turn away from the longitudinal axis 6. A lip length 178 can be  
23 the length between a first lip edge 180 of the engagement element 148 on the first  
24 length 172 or third length 176 and a second lip edge 182 of the engagement element  
25 148 on the second length 174. The lip length 178 can be small enough to form a  
26 seam, crease or seat 184 to aid in seating, receiving and engaging a second prosthesis.

27 [0099] Figure 51 illustrates a length of the wall 4 that can have the lengths 172, 174  
28 and 176. The engagement elements 148 on the first length 172 and third length 176  
29 can turn away from the longitudinal axis 6. The engagement element 148 on the  
30 second length 174 can turn toward the longitudinal axis 6. The engagement element  
31 148 can then engage a second prosthesis on both sides of the wall 4.

32 [0100] Figure 52 illustrates an embodiment that can have springs 186. One segment  
33 of each spring 186 can be a latch 188. The springs 186 can have windings 190 around



1 a rail 192 fixed under the engagement element 148. The springs 186 can also have  
2 retaining legs 194 pressed against the wall 4. The latches 188 can be biased to  
3 contract, as shown by arrows 196, against the wall 4. The latches 188 can be held in  
4 the uncontracted position shown in Figure 52 by interference beams 198. The  
5 interference beams 198 can be directly or indirectly rigidly attached to each other at a  
6 proximal end (in the direction of arrows 200) to minimize the interference beams 198  
7 from deflecting under the force, shown by arrows 196, from the latches 188. The  
8 interference beams 198 can be removed, as shown by arrows 200, allowing the latches  
9 188 to contract, as shown by arrows 196, against, for example, the second prosthesis,  
10 once the second prosthesis is positioned within the reach of the latches 188.

11

## 12 METHOD OF MAKING

13 **[0101]** The wall 4 can be made from methods known to one having ordinary skill in  
14 the art. For example, the wall 4 can be molded or machined. The engagement  
15 element 148, the corrugation and any other bends in the wall 4 can be formed (e.g.,  
16 pressure formed), molded or machined into the wall 4 or bent into the metal with  
17 methods known to one having ordinary skill in the art.

18 **[0102]** The protrusions 26 and 28 and the receiving elements 32 and 34 (e.g., at the  
19 connection zone 118) can be fixed to the to the wall 4 or formed of the wall 4 by  
20 crimping, stamping, melting, screwing, gluing, welding, die cutting, laser cutting,  
21 electrical discharge machining (EDM) or a combination thereof. Cuts 162 and holes  
22 in the wall 4 can be made by die cutting, lasers or EDM.

23 **[0103]** Any part of the first prosthesis 2, or the first prosthesis 2 as a whole after  
24 assembly, can be coated by dip-coating or spray-coating methods known to one  
25 having ordinary skill in the art. One example of a method used to coat a medical  
26 device for vascular use is provided in U.S. Patent No. 6,358,556 by Ding et al. and  
27 hereby incorporated by reference in its entirety. Time release coating methods known  
28 to one having ordinary skill in the art can also be used to delay the release of an agent  
29 in the coating. The coatings can be thrombogenic or anti-thrombogenic. For  
30 example, coatings on the inside of the first prosthesis 2, the side facing the  
31 longitudinal axis 6, can be anti-thrombogenic, and coatings on the outside of the first  
32 prosthesis, the side facing away from the longitudinal axis 6, can be thrombogenic.

1 [0104] The first prosthesis 2 can be covered with a fabric, for example polyester  
2 (e.g., DACRON® from E. I. du Pont de Nemours and Company, Wilmington, DE),  
3 polypropylene, PTFE, ePTFE, nylon, extruded collagen, silicone or combinations  
4 thereof. Methods of covering an implantable device with fabric are known to those  
5 having ordinary skill in the art.

6

#### 7 METHOD OF USE

8 [0105] The first prosthesis 2 can be introduced in an unexpanded state to an  
9 antechamber 202 adjacent to a targeted valve annulus 204 by methods known to one  
10 having ordinary skill in the art. Figure 53 illustrates positioning and lowering, as  
11 shown by the arrows, the first prosthesis 2 to the annulus 204. Because of the  
12 collapsible and expandable nature of the first prosthesis 2, the procedure of  
13 implanting the first prosthesis 2 can be accomplished thoroscopically, endoscopically  
14 and/or endoluminally. The first prosthesis 2 can be placed accurately enough into the  
15 annulus 204 so that the first prosthesis 2 does not block vessel openings in chambers  
16 neighboring the annulus 204 (e.g., the openings for the coronary vessels) and does not  
17 fall out of the annulus 204 (e.g., into a chamber of the heart, a ventricle for example).  
18 The annulus 204 can have an initial annulus diameter 206. Figure 54 illustrates  
19 positioning and seating the first prosthesis 2.

20 [0106] When the first prosthesis 2 is completely unexpanded, the protrusion 26 and  
21 the receiving element 32 can be aligned as illustrated in Figures 55 and 56. As shown  
22 in Figure 55, the extension 130 can be located in the first setting position 98. As  
23 shown in Figure 56, the ball 50 can be located in the first setting position 98.

24 [0107] The first prosthesis 2 can be circumferentially expanded, as illustrated by the  
25 arrows in Figure 57. The prosthesis can have an expanded annulus diameter 208.  
26 The expanded annulus diameter 208 can be from about 5 mm (0.2 in.) to about 40 mm  
27 (1.6 in.), depends on the size of the initial annulus diameter 206, and can be  
28 influenced by other anatomy, anomalies (e.g., narrowing, stenosis) and age (e.g.,  
29 pediatric sizing). An expansion tool 210 can be used to expand the first prosthesis 2.  
30 Examples of the expansion tool 210 include a balloon, back sides of a clamp jaws, or  
31 a flexible plug assembly as shown in Figures 58-61. Another example of the  
32 expansion tool 210 is disclosed in U.S. Patent No. 5,984,959 to Robertson et al. which  
33 is herein incorporated by reference in its entirety.

1 [0108] Figure 58 illustrates a flexible plug 212 that can be cylindrical and have a  
2 static plate 214 on a first side 216. The plug 212 can be made from polymers, for  
3 example polyurethane or silicone. The plug 212 can have a hole 218 in the center of  
4 the plug 212. A rigid inner tube 220 can pass through the hole 218 and be tied into a  
5 knot or pull against a washer 222 on the first side 216. A squeeze plate 224 can be  
6 fixedly attached to an end of a rigid outer tube 226. The outer tube 226 can be larger  
7 than the inner tube 220, and the inner tube 220 can slide through the outer tube 226.  
8 A force in the direction of the plug 212 can be applied to the outer tube 226, as shown  
9 by arrows 228. A force in the direction away from the plug 212 can be applied to the  
10 inner tube 220, as shown by arrows 230. The plug can have a resting diameter 232  
11 when no forces are applied.

12 [0109] Once the forces shown by the arrows 228 and 230 are applied to the plug  
13 212, the plug 212 can deform away from the tubes 220 and 226, as shown by arrows  
14 234 and illustrated in Figure 59. Once deformed, the plug 212 can have an expanded  
15 diameter 236. The resting diameter 232 and the expanded diameter 236 can be sized  
16 appropriately to the dimensions of the first prosthesis 2. The deformation of the plug  
17 212 can also create forces in the same direction as the arrows 234. When the forces  
18 shown by the arrows 228 and 230 are removed, the plug 212 can return to the shape  
19 shown in Figure 58.

20 [0110] Figure 60 illustrates another embodiment of the plug 212. The plug 212 can  
21 have a recessed top surface 238 and a recessed bottom surface 240. A top perimeter  
22 242 and a bottom perimeter 244 can be angled from the recessed surfaces 238 and 240  
23 to meet a wall 246 of the plug 212. The squeeze plate 224 and the static plate 214 can  
24 both be conically or partially conically shaped to fit the perimeters 242 and 244 of the  
25 plug 212. As shown in Figure 61, when the forces shown by the arrows 228 and 230  
26 are applied, the plug wall 246 can expand radially and maintain a flat surface.

27 [0111] When the first prosthesis 2 is completely expanded, the protrusion 26 and the  
28 receiving element 32 can be aligned as illustrated in Figures 62 and 63. As shown in  
29 Figure 62, the extension 130 can be located in the final stop position 110. As shown  
30 in Figure 63, the ball 50 can be located in the final stop position 110. The  
31 interference fit caused by the stop angle 116 and neck width 104 of the second neck  
32 108 can prevent the protrusion 26 from re-entering the second setting position 106. In  
33 addition, when expanded the first prosthesis frictionally engages the annulus,

1 expanding the annulus diameter. When expanded, the first prosthesis 2 can also trap  
2 vascular plaque between the wall 4 and the perimeter of the annulus 204. The first  
3 prosthesis 2 can also be partially expanded, forcing the protrusion 26 into the second  
4 setting position 106.

5 [0112] Fixturing devices 248 can be used to fix the first prosthesis 2 through the  
6 fixturing device connectors 88 to the biological mass of the annulus 204, as shown in  
7 Figure 64. Examples of fixturing devices 88 are sutures, clips, staples, pins and  
8 combinations thereof.

9 [0113] Figures 65-68 illustrate one embodiment of a method of fixing the first  
10 prosthesis 2 to the annulus 204. Figure 65 illustrates an embodiment of a fixturing  
11 device assembly 250. The fixturing device assembly 250 can have a needle 252. The  
12 needle 252 can be curved or have a curved tip. The needle 252 can also be attached at  
13 a proximal end to a distal end of a line 254. The proximal end of the needle 252 can  
14 also be attached directly to the can 256 without the line 254 or formed as the can 256.  
15 A proximal end of the line 254 can be attached to a can 256. The can 256 can be a  
16 flexible cylindrical storage device, for example a coil. The can 256 can removably  
17 hold the fixturing device 148. The fixturing device 148 can have a fixturing element  
18 258, for example a wire or fiber. The fixturing element 258 can have a ball 260 at a  
19 first end and a radially expandable portion 262 at a second end. The fixturing device  
20 248 can also have a pledget 264 on the fixturing element 258 between the ball 260  
21 and the expandable portion 262.

22 [0114] The fixturing device assembly 250 can be positioned so the needle 252 is  
23 adjacent to the fixturing device connector 88, as shown by arrows 266. The needle  
24 252 can then be pushed through the fixturing device connector 88 and the annulus  
25 204, as shown by arrow 268 in Figure 66. The needle 252 can then be pulled away  
26 from the annulus 204, as shown by arrow 270 in Figure 67. The can 256 can follow  
27 the path of the needle 252 through the annulus 204, as shown by arrow 272. The  
28 pledget 264 can also be larger than the fixturing device connector 88, and the pledget  
29 264 can provide an interference fit against the fixturing device connector 88. The  
30 needle 252 can continue to be pulled away from the annulus 204, pulling the can 256  
31 out of the annulus 204, as shown by arrow 274 in Figure 68. The interference fit of  
32 the pledget 264 against the fixturing device connector 88 can provide a resistive force  
33 holding the fixturing device 248 and causing the fixturing element 258 to slide out of

1 the can 256 as the needle 252 is pulled away from the annulus 204. The radially  
2 expandable portion 262 can then radially expand, thereby causing the first prosthesis  
3 2 and the annulus 204 to be fixed between the pledget 264 and the radially expandable  
4 portion 262.

5 **[0115]** The inner surface of the can 256 can be designed - for example by coiling,  
6 corrugation, or other roughening – to adjust the friction between the inner surface of  
7 the can 256 and the fixturing device 148. This friction can influence the amount of  
8 resistive force necessary to remove the fixturing device 148 from the can 256. The  
9 resistive force can be larger than about the force necessary to have the fixturing  
10 device 148 fall out of the can 256 before the fixturing device 148 has passed through  
11 the annulus 104. The resistive force can also be less than about the force necessary to  
12 deform the pledget 264 sufficient to pull the pledget 256 through the fixturing device  
13 connector 88. The resistive force can be, for example, about 1.1 N (0.25 lbs.).

14 **[0116]** A second prosthesis 68 can then be positioned on the engagement element  
15 148, as shown by the arrows in Figure 69. Once seated on the engagement element  
16 148, the second prosthesis 68 can then be engaged by the first prosthesis 2, as shown  
17 in Figure 70. Examples of second prostheses 68 include a connection adapter and a  
18 heart valve crown with leaflets 276, for example, U.S. Patent No. 6,371,983 to Lane  
19 which is herein incorporated by reference in its entirety.

20 **[0117]** Figure 71 illustrates another embodiment of the heart valve assembly 278  
21 with the second prosthesis 68. The first prosthesis 2 can have a tapered wall 280 to  
22 provide a longitudinal stop and to guide insertion of the second prosthesis 68 into the  
23 first prosthesis 2, as shown by arrows 282. The tapered wall 280 can also push back  
24 the annulus 204, maintaining the expanded annulus diameter 208 when the second  
25 prosthesis 68 is engaged in the first prosthesis 2. The second prosthesis 68 can have  
26 spring lock tabs 284 to fix to the engagement element 148. The spring lock tabs 284  
27 can angle outwardly from the longitudinal axis 6. The first and second prostheses 2  
28 and 68 can have first and second prosthesis diameters 288 and 290, respectively. The  
29 first prosthesis diameter 288 can be larger than the second prosthesis diameter 290.  
30 Figure 72 illustrates the embodiment of the heart valve assembly 278 of Figure 71,  
31 however the second prosthesis diameter 290 can be larger than the first prosthesis  
32 diameter 288, and the spring lock tabs 284 can angle inwardly toward the longitudinal

1 axis 6. The first prosthesis 2 and the second prosthesis 68 act to maintain the  
2 expanded annular lumen diameter 208.

3 **[0118]** Figure 73 illustrates another embodiment of the heart valve assembly 278  
4 with a second prosthesis 68 that can have fixation points 286 that align with fixation  
5 points 286 on the first prosthesis 2 to allow insertion of sutures, grommets, clips 292  
6 or pins 294 through the aligned fixation points 286 to fix the first prosthesis 2 to the  
7 second prosthesis 68.

8 **[0119]** Figure 74 illustrates another embodiment of the heart valve assembly 278  
9 with a multi-lobed stiffening ring 296 that can be placed near the edge of the second  
10 prosthesis 68 as shown by arrows 298. The second prosthesis 68 can have several  
11 flaps 300. The flaps 300 can wrap around the stiffening ring 296, as shown by arrows  
12 302. The wrapped stiffening ring 296 can increase the rigidity of the second  
13 prosthesis 68 and can engage the engagement element 148.

14 **[0120]** Figure 75 illustrates yet another embodiment of the heart valve assembly 278  
15 with an embodiment of the first prosthesis 2 equivalent to the embodiment in Figure  
16 52. The second prosthesis 68 can have latch openings 304 to receive the latches 188.  
17 When the second prosthesis 68 is lowered into the first prosthesis 2, the interference  
18 beams 198 can be removed, as shown by arrows 200. The latches 188 can then  
19 contract onto the latch openings 304.

20 **[0121]** Figure 76 illustrates an embodiment of the heart valve assembly 278 with an  
21 embodiment of the first prosthesis 2 equivalent to the embodiment in Figures 11 and  
22 12. The second prosthesis can have a rib 306 to fit within the groove 64. The second  
23 prosthesis 68 can also have an upper arm 308 that can have a top magnet 70 and a  
24 lower arm 310 that can have a bottom magnet 72. The magnets 70 and 72 in the  
25 second prosthesis 68 can have polarities opposite of the polarities of the  
26 corresponding magnets 70 and 72 in the first prosthesis 2. Figure 77 illustrates an  
27 embodiment of the heart valve assembly 278 with an embodiment of the first  
28 prosthesis equivalent to the embodiment in Figures 13 and 14.

29 **[0122]** Figure 78 illustrates an embodiment of the heart valve assembly 278 with an  
30 adapter 312 connecting the second prosthesis 68 to the first prosthesis 2. The adapter  
31 312 can have spring lock tabs 284 to fix to the engagement element 148, and the  
32 adapter 312 can have a stop ridge 314 to position the adapter 312 against the wall 4.

1 [0123] The adapter 312 can also have fixation points 286 that align with other  
2 fixation points 286 on the second prosthesis 68 to allow insertion of sutures,  
3 grommets, clips, pins, or the fixturing devices 248, through the aligned fixation points  
4 286 to fix the adapter 312 to the second prosthesis 68. The second prosthesis 68 can  
5 also be lowered into the top of the adapter 312 as shown by arrow 316. The adapter  
6 312 can attach to the inside or outside of the first or second prosthesis 2 or 68  
7 depending on the dimensions and the orientation of the attachment apparatus (e.g.,  
8 unidirectional clips).

9 [0124] The adapter 312 can also have multiple shapes of cross-sections, as shown in  
10 Figures 79 and 80. As shown in Figure 79, cross-section C-C can have three lobes  
11 318 and three scallops 320. One scallop 320 can be between each lobe 318. Cross-  
12 section C-C can be the same as the cross-section of the second prosthesis 68 where  
13 the second prosthesis 68 engages the adapter 312. As shown in Figure 80, cross-  
14 section D-D can be circular. Cross-section D-D can be the same as the cross-section  
15 of the first prosthesis 2 where the first prosthesis 2 engages the adapter 312.

16 [0125] Figure 81 illustrates a second prosthesis 68 received by a first prosthesis 2.  
17 The second prosthesis 68 can have three lobes 318. The second prosthesis can have a  
18 scallop 320 between each two lobes 318. The scallop gap 322 between each scallop  
19 320 and the wall 4 can be covered by a fabric during use of the prostheses 2 and 68.

20 [0126] Figure 82 illustrates that a lever device 324, for example a clamp or scissors,  
21 can be forced, as shown by arrows, into the scallop gap 322. As illustrated in Figure  
22 83, once legs 326 of the lever device 324 are placed next to two scallops 320, the  
23 lever device 324 can be squeezed, as shown by arrows, thereby crushing the second  
24 prosthesis 68 and separating it from the first prosthesis 2. As illustrated in Figure 84,  
25 the second prosthesis 68 can be removed from the first prosthesis 2, as shown by  
26 arrows, once the second prosthesis 68 is separated from the first prosthesis 2. Once  
27 the second prosthesis 68 is removed, a new second prosthesis 68 can be added as  
28 described above. Leaflet failure can be fixed easily and inexpensively by implanting  
29 a new second prosthesis 68. Circumferential expansion of the first prosthesis 2 and  
30 replacement of the second prosthesis 68 to account for pediatric expansion of the  
31 valve can also be performed easily and inexpensively.

32 [0127] It is apparent to one skilled in the art that various changes and modifications  
33 can be made to this disclosure, and equivalents employed, without departing from the

- 1 spirit and scope of the invention. Elements shown with any embodiment are
- 2 exemplary for the specific embodiment and can be used on other embodiments within
- 3 this disclosure.
- 4



1  
2  
3  
4  
5  
6  
7  
8  
9  
10  
11  
12  
13  
14  
15  
16  
17  
18  
19  
20  
21  
22  
23  
24  
25  
26  
27  
28  
29  
30  
31  
32

## CLAIMS

We claim:

1. A biologically implantable first prosthesis for a heart valve comprising:
  - a circumferentially expandable wall, wherein the wall has a longitudinal axis, and wherein the wall has a latitudinal cross-section perpendicular to the longitudinal axis, and wherein the wall has a longitudinal cross-section parallel to the longitudinal axis, and
  - an engagement element configured to self-engage a second prosthesis.
2. The first prosthesis of Claim 1, further comprising a stop, wherein the stop prevents the wall from circumferentially decreasing.
3. The first prosthesis of Claim 2, wherein the stop prevents the wall from circumferentially expanding.
4. The first prosthesis of Claim 2, wherein the wall is resiliently expandable.
5. The first prosthesis of Claim 2, wherein the wall is deformably expandable.
6. The first prosthesis of Claim 2, wherein the wall is mechanically expandable.
7. The first prosthesis of Claim 2, wherein the latitudinal cross-section comprises an open form.
8. The first prosthesis of Claim 2, wherein the latitudinal cross-section comprises a spiral.
9. The first prosthesis of Claim 2, wherein the wall comprises a first terminal end.
10. The first prosthesis of Claim 9, wherein the wall comprises a second terminal end.

- 1 11. The first prosthesis of Claim 9, wherein the latitudinal cross-section comprises a  
2 spiral.  
3
- 4 12. The first prosthesis of Claim 9, further comprising a first protrusion.  
5
- 6 13. The first prosthesis of Claim 12, wherein the first protrusion is attached to the  
7 wall.  
8
- 9 14. The first prosthesis of Claim 13, wherein the first protrusion extends from the  
10 wall with a vector having a radial component with respect to the longitudinal axis.  
11
- 12 15. The first prosthesis of Claim 14, wherein the first protrusion comprises a dimple.  
13
- 14 16. The first prosthesis of Claim 15, wherein the first protrusion comprises a tab.  
15
- 16 17. The first prosthesis of Claim 16, further comprising a receiving element.  
17
- 18 18. The first prosthesis of Claim 17, wherein the receiving element comprises an  
19 element in the wall.  
20
- 21 19. The first prosthesis of Claim 12, wherein the first protrusion extends from the  
22 wall with a vector having an angular component with respect to the longitudinal axis.  
23
- 24 20. The first prosthesis of Claim 19, wherein the first protrusion comprises a ball.  
25
- 26 21. The first prosthesis of Claim 20, further comprising a receiving element.  
27
- 28 22. The first prosthesis of Claim 21, wherein the receiving element comprises a  
29 collar.  
30
- 31 23. The first prosthesis of Claim 9, further comprising a receiving element.  
32

- 1 24. The first prosthesis of Claim 23, wherein the receiving element is configured to  
2 receive a protrusion extending from the wall with a vector with a radial component  
3 with respect to the longitudinal axis.  
4
- 5 25. The first prosthesis of Claim 24, wherein the receiving element is configured to  
6 receive a protrusion extending from the wall with a vector having an angular  
7 component with respect to the longitudinal axis.  
8
- 9 26. The first prosthesis of Claim 12, further comprising a second protrusion.  
10
- 11 27. The first prosthesis of Claim 26, wherein the first protrusion is located at a first  
12 length along the longitudinal axis and wherein the second protrusion is located at a  
13 second length along the longitudinal axis.  
14
- 15 28. The first prosthesis of Claim 26, wherein the first protrusion and the second  
16 protrusion are located at a first length along the longitudinal axis.  
17
- 18 29. The first prosthesis of Claim 26, wherein the first protrusion comprises a first tab,  
19 and the first prosthesis further comprises a first port in the wall for receiving the first  
20 tab.  
21
- 22 30. The first prosthesis of Claim 29, wherein the second protrusion comprises a  
23 second tab and a second port in the wall for receiving the second tab.  
24
- 25 31. The first prosthesis of Claim 29, wherein the second protrusion comprises a ball,  
26 and the first prosthesis further comprises a collar for receiving the ball.  
27
- 28 32. The first prosthesis of Claim 1, further comprising a fixturing device connector.  
29
- 30 33. The first prosthesis of Claim 32, wherein the fixturing device connector  
31 comprises a port in the wall.  
32
- 33 34. The first prosthesis of Claim 1, wherein the wall is corrugated.

1

2 35. The first prosthesis of Claim 1, wherein the wall has a leading edge and a trailing  
3 edge, and further comprising a turned lip on the leading edge.

4

5 36. A heart valve assembly comprising:

6 the first prosthesis of Claim 1, and

7 the second prosthesis received by the first prosthesis.

8

9 37. The assembly of claim 36, wherein the second prosthesis is a crown.

10

11 38. The assembly of claim 37, wherein the crown is engaged by the engagement  
12 element.

13

14 39. The assembly of claim 37, wherein the crown comprises a leaflet.

15

16 40. The assembly of claim 36, wherein the first prosthesis is a ring.

17

18 41. The assembly of Claim 36, wherein the second prosthesis is fixedly connected to  
19 the first prosthesis.

20

21 42. The assembly of Claim 36, wherein the second prosthesis is removably connected  
22 to the first prosthesis.

23

24 43. The assembly of Claim 36, wherein the second prosthesis is snap-fitted to the first  
25 prosthesis.

26

27 44. A biologically implantable prosthetic assembly for a heart valve comprising:

28 the first prosthesis of Claim 32, and

29 a fixturing device attached to the fixturing device connector, wherein the  
30 fixturing device fixes the first prosthesis to a biological mass.

31

32 45. The assembly of Claim 44, wherein the fixturing device comprises a suture.

33

- 1 46. The assembly of Claim 44, wherein the fixturing device comprises a clip.  
2
- 3 47. The assembly of Claim 44, wherein the fixturing device comprises a staple.  
4
- 5 48. The assembly of Claim 44, wherein the fixturing device comprises a pin.  
6
- 7 49. The assembly of Claim 44, wherein the fixturing device comprises a radially  
8 expandable wire.  
9
- 10 50. A biologically implantable first prosthesis for a heart valve comprising:  
11 a wall comprising a first edge and a second edge, wherein the wall has a  
12 longitudinal axis at the center of the first prosthesis, and wherein at least a portion of  
13 the wall is angled away from or toward the longitudinal axis, and wherein the first  
14 edge comprises an engagement element for engaging a second prosthesis.  
15
- 16 51. The first prosthesis of Claim 50, wherein the engagement element is turned  
17 toward the second edge.  
18
- 19 52. The first prosthesis of Claim 50, wherein the first edge is the leading edge.  
20
- 21 53. The first prosthesis of Claim 50, wherein the engagement element is turned  
22 toward the longitudinal axis.  
23
- 24 54. The first prosthesis of Claim 50, wherein the engagement element is turned away  
25 from the longitudinal axis.  
26
- 27 55. The first prosthesis of Claim 50, wherein the engagement element comprises a  
28 first segment and a second segment, and wherein the first segment is turned away  
29 from the longitudinal axis and the second segment is turned toward the longitudinal  
30 axis.  
31
- 32 56. The first prosthesis of Claim 50, further comprising a fixturing device connector.  
33

- 1 57. The first prosthesis of Claim 56, wherein the fixturing device connector  
2 comprises a port in the wall.  
3
- 4 58. The first prosthesis of Claim 50, wherein the wall is corrugated.  
5
- 6 59. The first prosthesis of Claim 50, wherein the longitudinal cross-section comprises  
7 a convex curve with respect to the longitudinal axis.  
8
- 9 60. The first prosthesis of Claim 50, wherein the longitudinal cross-section is a  
10 convex curve with respect to the longitudinal axis.  
11
- 12 61. The first prosthesis of Claim 50, wherein the wall is circumferentially  
13 expandable.  
14
- 15 62. A heart valve assembly comprising:  
16 the first prosthesis of Claim 50, and  
17 the second prosthesis, wherein the second prosthesis is connected to the  
18 engagement element.  
19
- 20 63. The assembly of claim 62, wherein the second prosthesis is a crown.  
21
- 22 64. The assembly of claim 63, wherein the crown is engaged by the engagement  
23 element.  
24
- 25 65. The assembly of claim 63, wherein the crown comprises a leaflet.  
26
- 27 66. The assembly of claim 62, wherein the first prosthesis is a ring.  
28
- 29 67. The assembly of Claim 62, wherein the second prosthesis is fixedly connected to  
30 the first prosthesis.  
31
- 32 68. The assembly of Claim 62, wherein the second prosthesis is removably connected  
33 to the first prosthesis.

1

2 69. The assembly of Claim 62, wherein the second prosthesis self-engages to the first  
3 prosthesis.

4

5 70. A heart valve assembly comprising:

6 a first prosthesis;

7 a first magnet in the first prosthesis;

8 a second prosthesis; and

9 a second magnet in the second prosthesis, wherein an attraction between the  
10 first magnet and the second magnet engages the first prosthesis to the second  
11 prosthesis.

12

13 71. A method of implanting a heart valve in a valve annulus comprising:

14 attaching a first prosthesis to the valve annulus, the first prosthesis comprising  
15 a circumferentially expandable wall, wherein the wall has a longitudinal axis, and  
16 wherein the wall has a latitudinal cross-section perpendicular to the longitudinal axis,  
17 and

18 self-attaching a second prosthesis to the first prosthesis.

19

20 72. The method of Claim 71, wherein the first prosthesis is a ring.

21

22 73. The method of Claim 71, wherein the second prosthesis is a crown.

23

24 74. The method of Claim 71, wherein the wall comprises a first terminal end.

25

26 75. The method of Claim 74, wherein the wall comprises a second terminal end.

27

28 76. The method of Claim 71, wherein the latitudinal cross-section comprises a spiral.

29

30 77. The method of Claim 71, wherein attaching the first prosthesis comprises  
31 positioning the first prosthesis in the annulus and circumferentially expanding the first  
32 prosthesis.

33

- 1 78. The method of Claim 71, wherein attaching the first prosthesis comprises fixing  
2 the first prosthesis to a biological mass with a fixturing device.  
3
- 4 79. The method of Claim 71, wherein attaching the first prosthesis comprises  
5 positioning the first prosthesis in the annulus.  
6
- 7 80. The method of Claim 71, wherein attaching the first prosthesis comprises snap-  
8 fitting the second prosthesis to the first prosthesis.  
9
- 10 81. The method of Claim 71, further comprising removing the second prosthesis.  
11
- 12 82. A method of changing a heart valve comprising removing a second prosthesis  
13 from a first prosthesis, wherein the first prosthesis is the first prosthesis of Claim 1.  
14
- 15 83. The method of Claim 82, further comprising replacing the second prosthesis with  
16 another prosthesis.  
17
- 18 84. A method of implanting a heart valve in a valve annulus comprising:  
19       attaching a first prosthesis to the valve annulus, the first prosthesis comprising  
20 a wall, wherein the wall comprises a first edge and a second edge, and wherein the  
21 wall has a longitudinal axis, and wherein at least a portion of the wall is angled away  
22 from or toward the longitudinal axis, and wherein the first edge comprises an  
23 engagement element, and  
24       attaching a second prosthesis to the first prosthesis.  
25
- 26 85. The method of Claim 84, wherein the engagement element is turned away from  
27 the longitudinal axis.  
28
- 29 86. The method of Claim 85, wherein the first prosthesis is a ring.  
30
- 31 87. The method of Claim 86, wherein the second prosthesis is a crown.  
32



- 1 88. The method of Claim 87, wherein the first edge is the leading edge and the  
2 second edge is the trailing edge.  
3
- 4 89. The method of Claim 88, wherein attaching the crown comprises snap-fitting the  
5 crown to the first prosthesis.  
6
- 7 90. The method of Claim 89, wherein the second edge comprises a retention element.  
8
- 9 91. A method of increasing and maintaining the size of a biological valve annulus  
10 comprising:  
11 placing a circumferentially expandable first prosthesis in the annulus,  
12 circumferentially expanding the first prosthesis to an expanded size, and  
13 circumferentially maintaining the first prosthesis at the expanded size.  
14
- 15 92. The method of Claim 91, wherein circumferentially expanding comprises  
16 increasing the radius of the annulus from about 0.1 mm to about 2.0 mm.  
17
- 18 93. The method of Claim 91, wherein the first prosthesis comprises an engagement  
19 element configured to receive a second prosthesis.  
20
- 21 94. A method of fixing a heart valve assembly to a biological mass comprising:  
22 positioning the assembly near the mass,  
23 inserting a fixation device through the assembly and the mass, wherein the  
24 fixation device comprises a first end, a second end, and a middle, and wherein the first  
25 end is expandable, and wherein the first end and the second end are on opposite sides  
26 of the assembly and the mass, and  
27 expanding the first end.  
28
- 29 95. A biologically implantable system for a heart valve comprising:  
30 a first prosthesis comprising tissue, and  
31 a second prosthesis comprising an engagement element, wherein the  
32 engagement element is configured to engage the first prosthesis in one or more  
33 parallel planes.

1

2 96. The system of claim 95, wherein the first prosthesis comprises a tissue leaflet.

3

4 96. A biologically implantable system for a heart valve comprising:

5 a first prosthesis comprising tissue, and

6 a second prosthesis having a longitudinal axis, the second prosthesis

7 comprising an engagement element configured to self-engage the first prosthesis.

8

9 98. The system of Claim 97, wherein the first prosthesis comprises a tissue leaflet.

10

11 99. The system of Claim 97, wherein the engagement element is configured to self-

12 engage the first prosthesis when the first prosthesis is moved relative to the second

13 prosthesis parallel to the longitudinal axis.

14

15 100. The system of Claim 97, wherein the second prosthesis comprises a

16 circumferentially expandable wall.

17

18 101. A biologically implantable first prosthesis for a heart valve comprising:

19 a first prosthesis comprising tissue, and an engagement element configured to

20 self-engage a second prosthesis.

21

22 102. The prosthesis of Claim 101, wherein the first prosthesis comprises a tissue

23 leaflet.

24

25 103. The prosthesis of Claim 101, wherein the engagement element is configured to

26 self-engage the second prosthesis when the first prosthesis is moved relative to the

27 second prosthesis parallel to a longitudinal axis of the second prosthesis.

28

29 104. A fixturing assembly comprising:

30 a needle comprising a needle body and a needle first end and a needle second end,

31 said needle second end comprising a can, and

1 a fixturing device comprising a fixturing device first end, a fixturing device second  
2 end, wherein at least a portion of the fixturing device first end is held by the can and  
3 removable from the can.

4

5 105. The assembly of Claim 104, wherein the needle comprises a curved portion.

6

7 106. The assembly of Claim 104, wherein the needle second end is directly attached to the  
8 can.

9

10 107. The assembly of Claim 104, wherein the needle second end is formed as the can.

11

12 108. The assembly of Claim 104, wherein the fixturing device second end comprises an  
13 interference fit piece.

14

15 109. The assembly of Claim 108, wherein the interference fit piece comprises a pledget.

16

17 110. The assembly of Claim 108, wherein the interference fit piece comprises a ball.

18

19 111. The assembly of Claim 110, further comprising a pledget retained by the ball.

20

21 112. The assembly of Claim 104, wherein the fixturing device first end comprises a  
22 radially expandable portion.

23

24 113. The assembly of Claim 112, wherein the radially expandable portion expands when  
25 the fixturing device first end is removed from the can.

26

27 114. A fixturing assembly comprising:

28 a needle comprising a needle second end,

29 a can comprising a can first end,

30 a line comprising a line first end and a line second end, wherein the line first end is  
31 attached to the needle second end and wherein the line second end is attached to the can  
32 first end, and

- 1 a fixturing device comprising a fixturing device first end and a fixturing device  
2 second end, wherein at least a portion of the fixturing device first end is frictionally  
3 engaged by and removable from the can.  
4
- 5 115. The assembly of Claim 114, wherein the line is a suture.  
6
- 7 116. The assembly of Claim 114, wherein the can comprises a flexible section.  
8
- 9 117. The assembly of Claim 116, wherein the flexible section comprises a coil.  
10
- 11 118. The assembly of Claim 114, further comprising an interference fit piece attached to  
12 the fixturing device second end.  
13
- 14 119. The assembly of Claim 118, wherein the interference fit piece comprises a pledget.  
15
- 16 120. The assembly of Claim 118, wherein the interference fit piece comprises a ball.  
17
- 18 121. The assembly of Claim 120, further comprising a pledget retained by the ball.  
19
- 20 122. The assembly of Claim 114, wherein the fixturing device first end comprises a  
21 radially expandable portion.  
22
- 23 123. The assembly of Claim 122, wherein the radially expandable portion expands when  
24 the fixturing device first end is removed from the can.  
25
- 26 124. A method of fixturing a first mass and a second mass, the method comprising:  
27 moving the fixation assembly of Claim 104 through the first mass and the second  
28 mass, and  
29 deploying the fixturing device from the can such that the fixturing device fixtures  
30 the first mass and the second mass.  
31
- 32 125. The method of Claim 124, wherein the fixturing device is frictionally engaged by the  
33 can.

1

2 126. The method of Claim 124, wherein deploying further comprises slidably releasing the  
3 fixturing device from the can.

4

5 127. The method of Claim 124, wherein the fixturing device further comprises an  
6 interference fit piece, and the method further comprises catching the interference fit piece  
7 on the first mass.

8

9 128. The method of Claim 124, wherein the fixturing device first end comprises an  
10 expandable portion, and wherein deploying further comprises expanding the expandable  
11 portion when the fixturing device first end deploys from the can.

12

13 129. A method of fixturing a first mass and a second mass, the method comprising:  
14 moving the fixation assembly of Claim 111 through the first mass and the second  
15 mass, and  
16 deploying the fixturing device from the can such that the fixturing device fixtures  
17 the first mass and the second mass.

18

19 130. The method of Claim 129, wherein the fixturing device is frictionally engaged by the  
20 can.

21

22 131. The method of Claim 129, wherein deploying further comprises slidably releasing the  
23 fixturing device from the can.

24

25 132. The method of Claim 129, wherein the fixturing device further comprises an  
26 interference fit piece, and the method further comprises catching the interference fit piece  
27 on the first mass.

28

29 133. The method of Claim 129, wherein the fixturing device first end comprises an  
30 expandable portion, and wherein deploying further comprises expanding the expandable  
31 portion when the fixturing device first end deploys from the can.

32

33

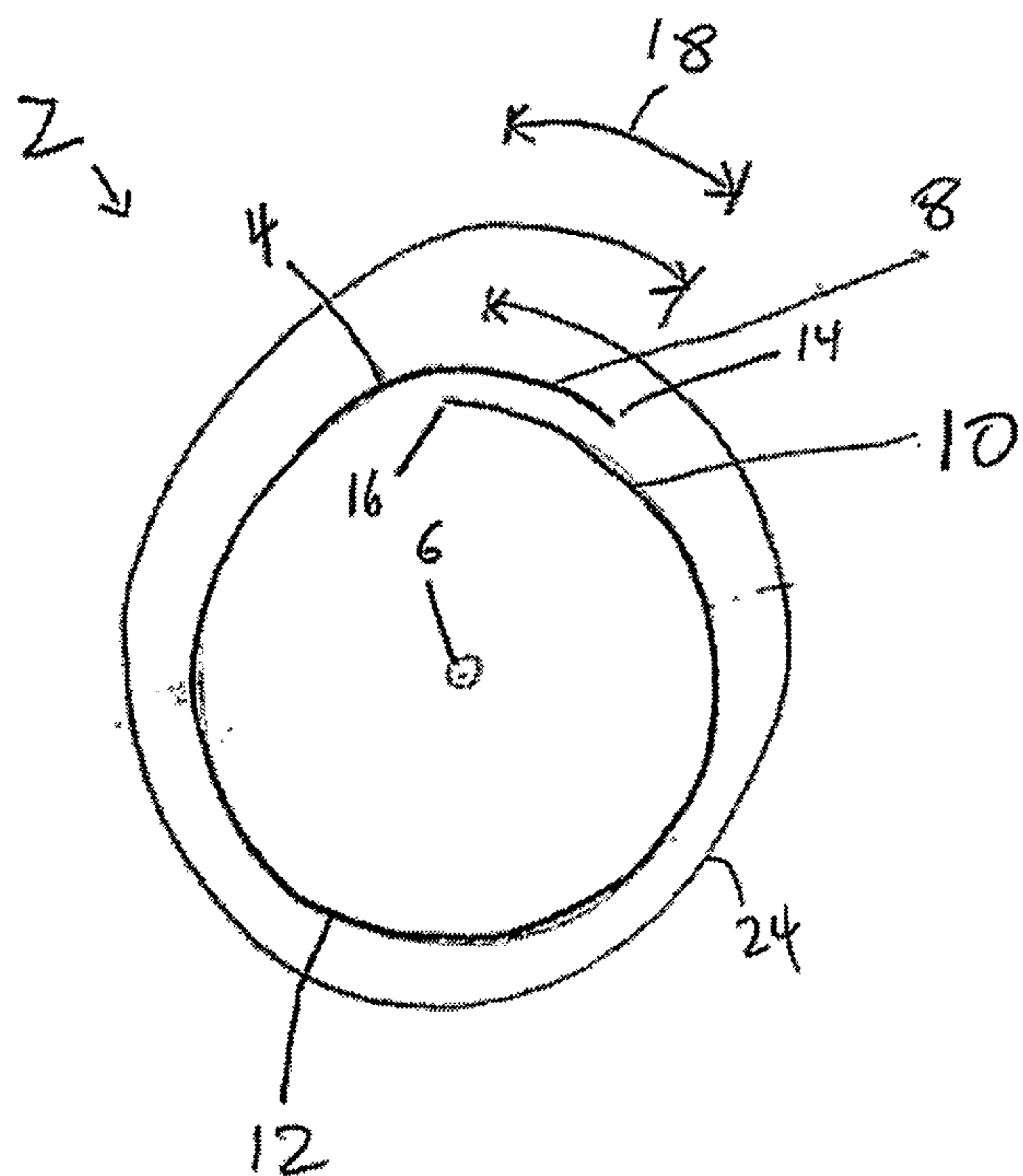

FIG. 1

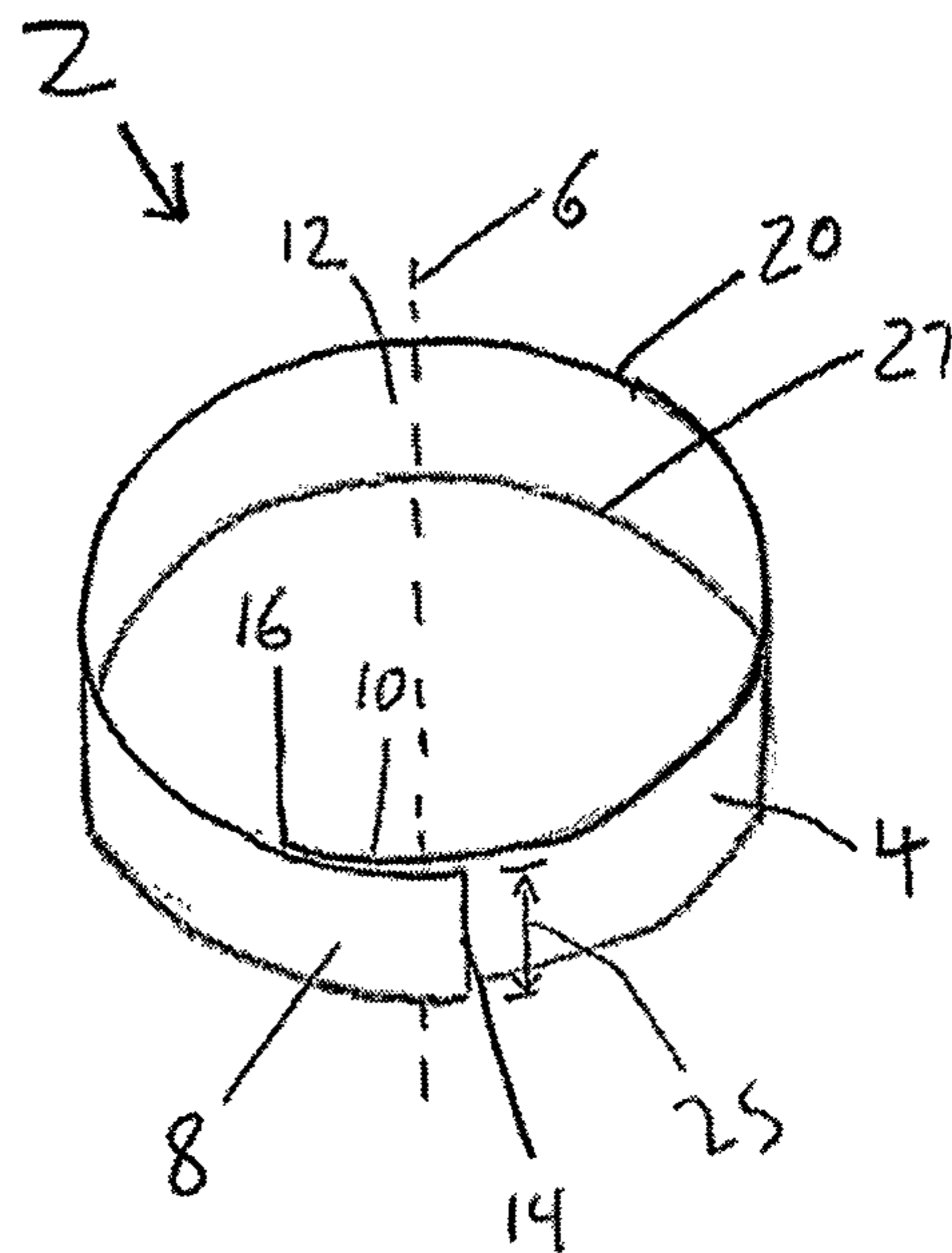

FIG. 2

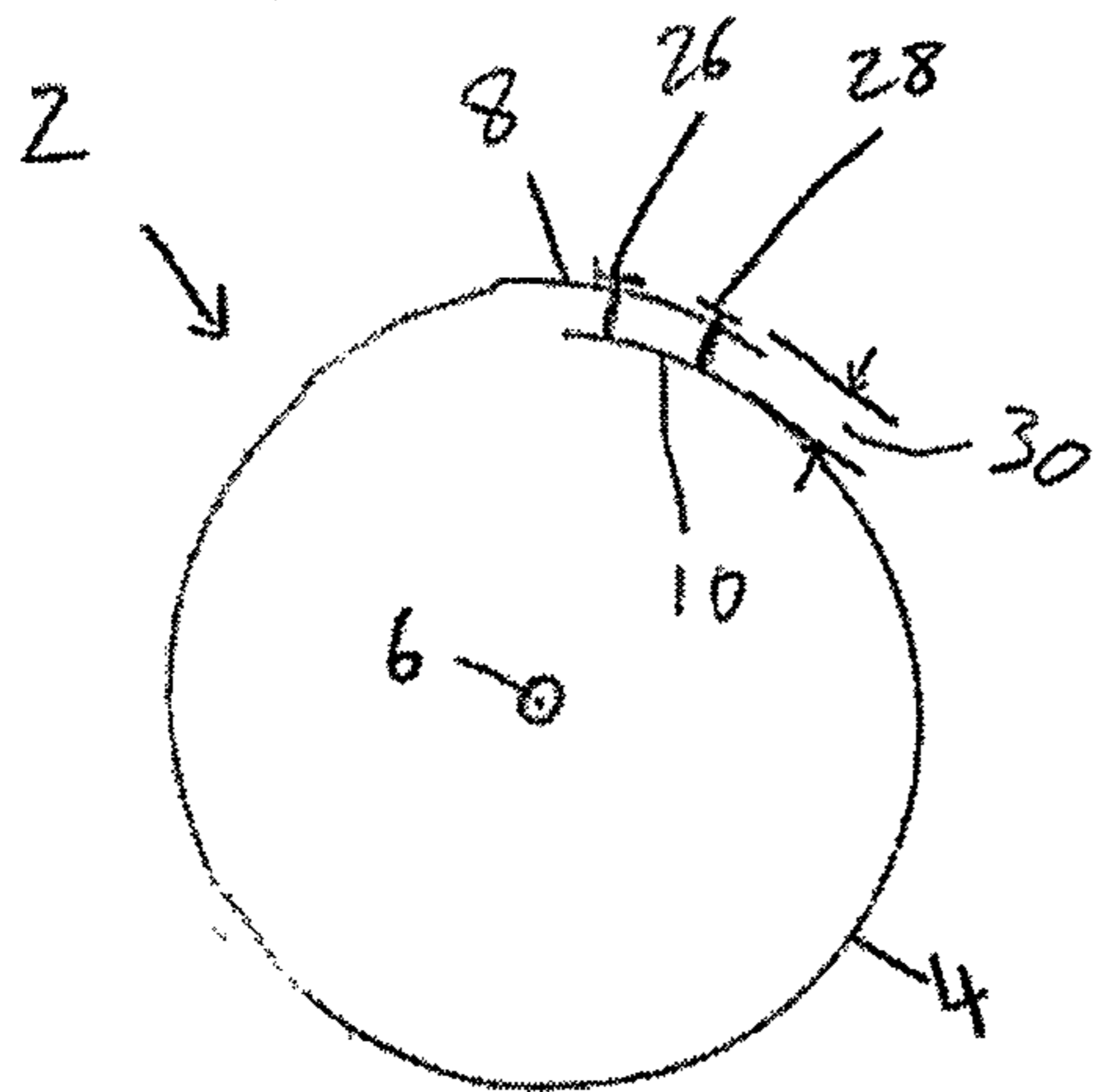

FIG. 3

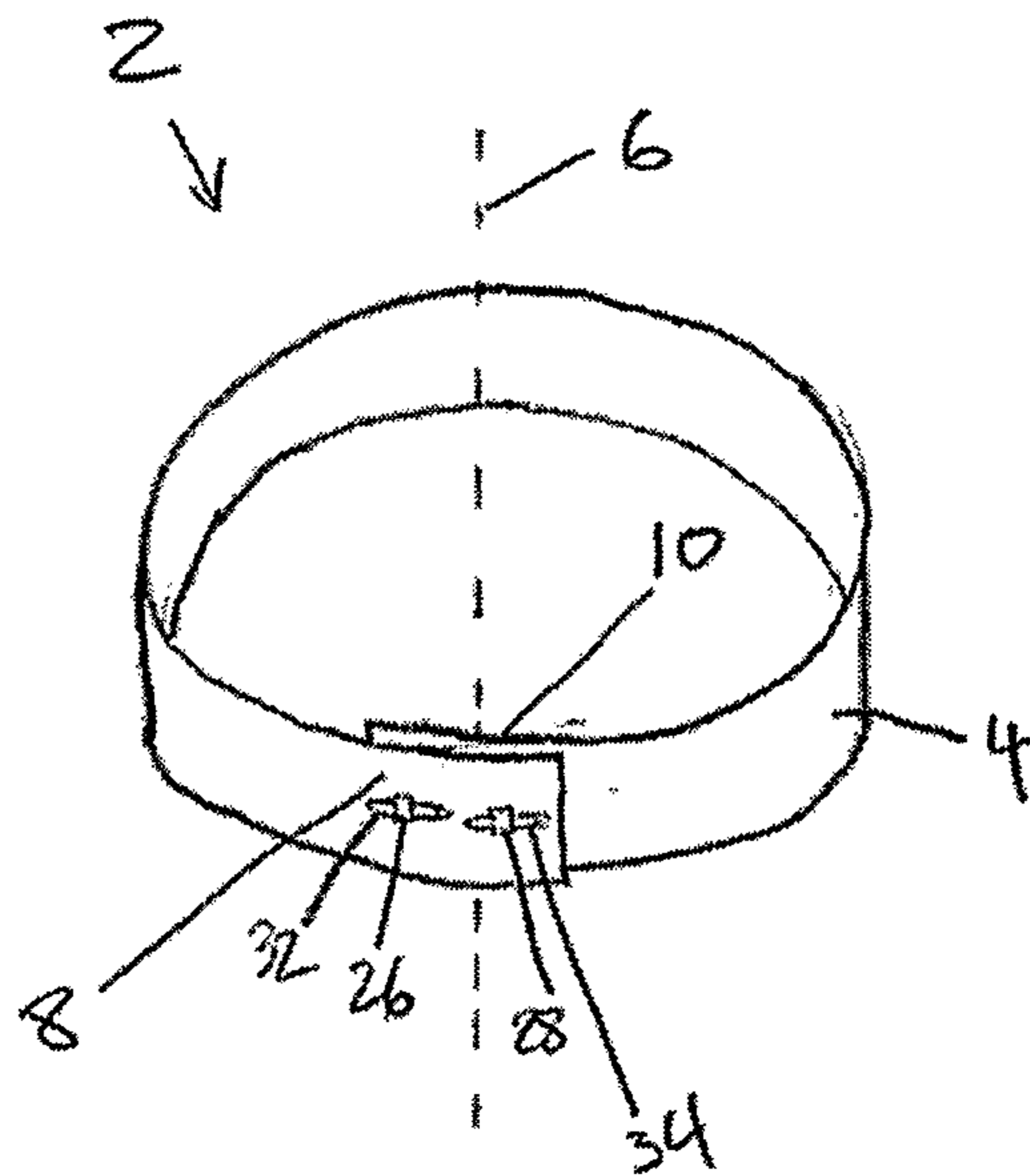

FIG. 4

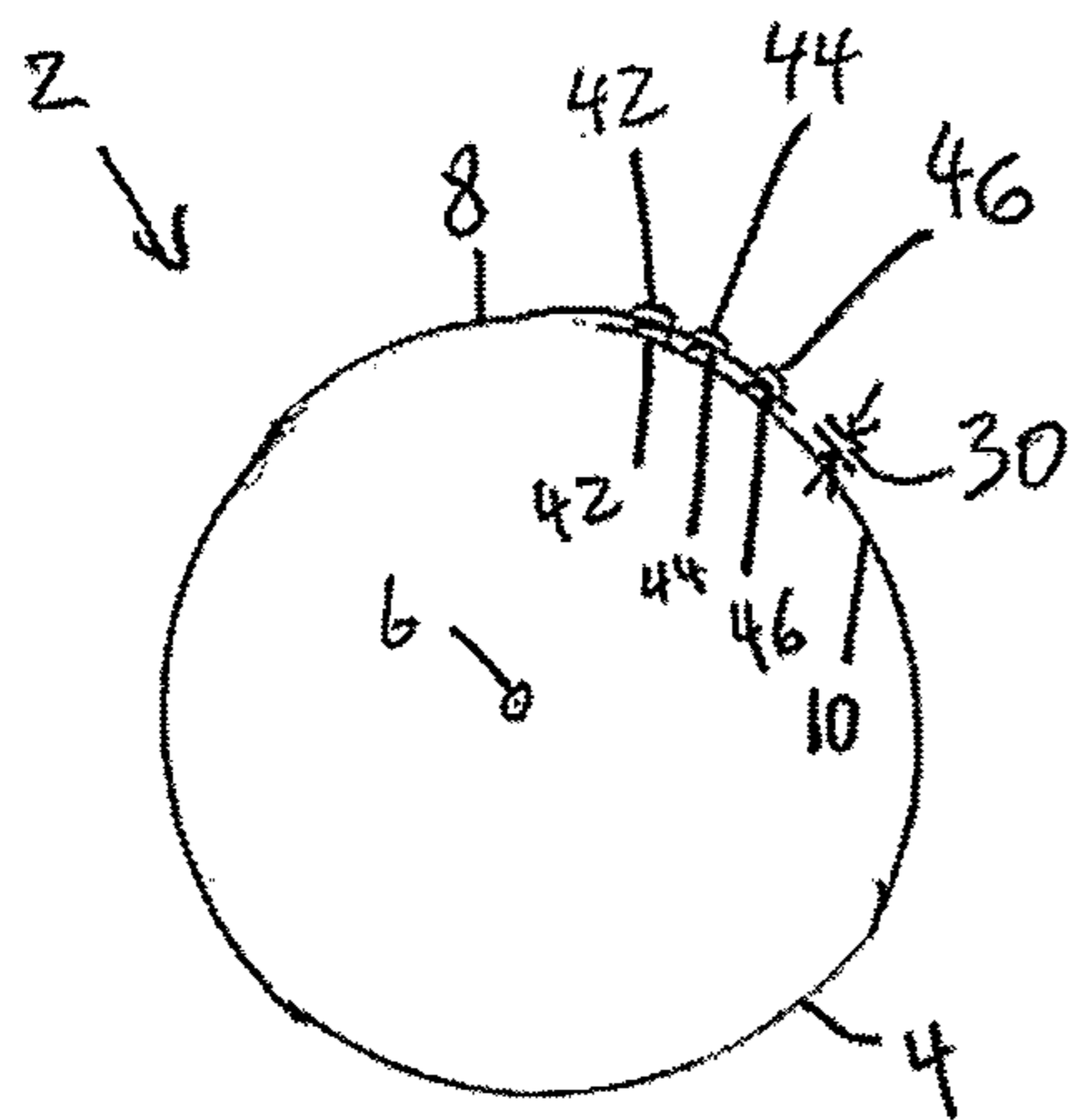

FIG. 5

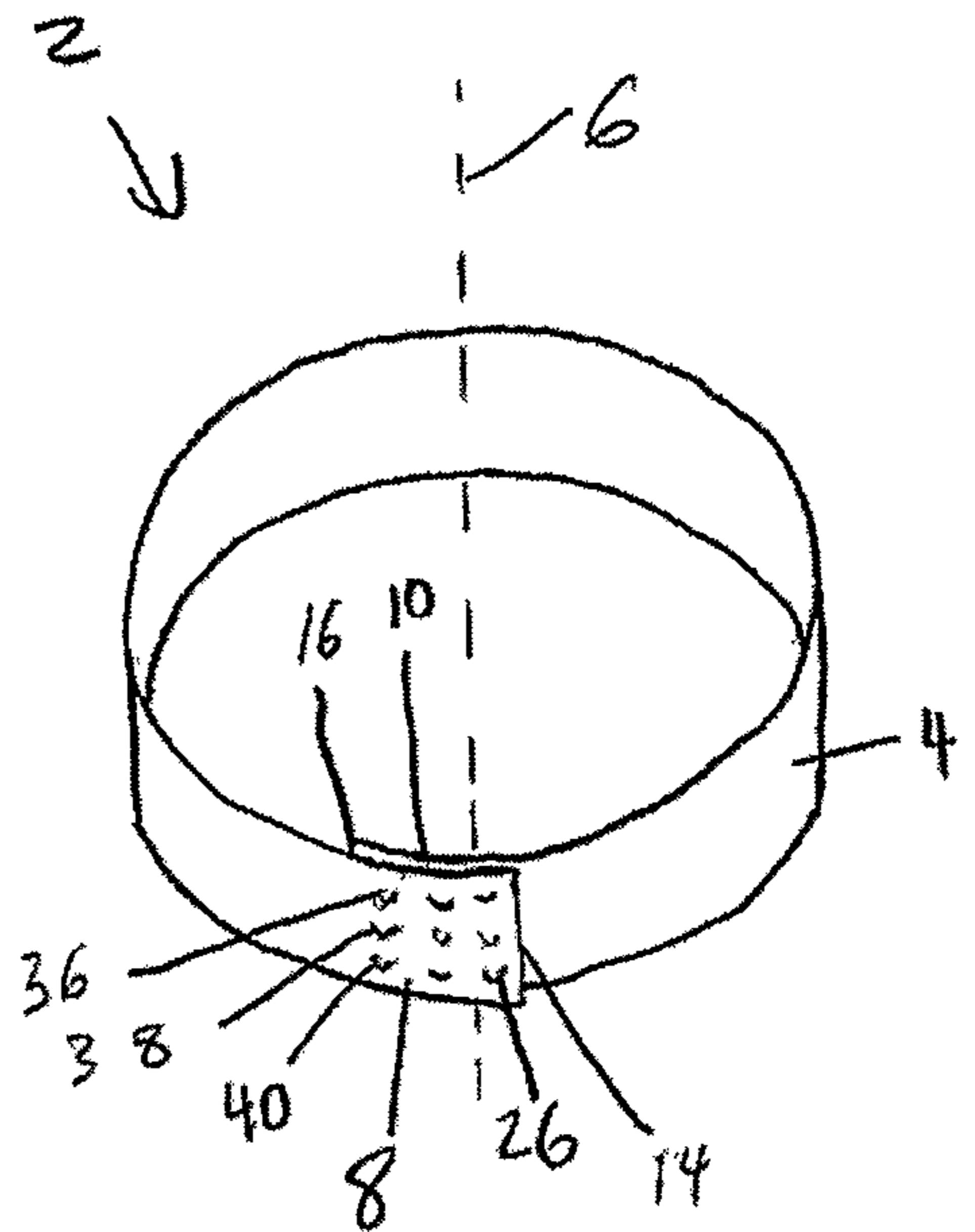

FIG. 6

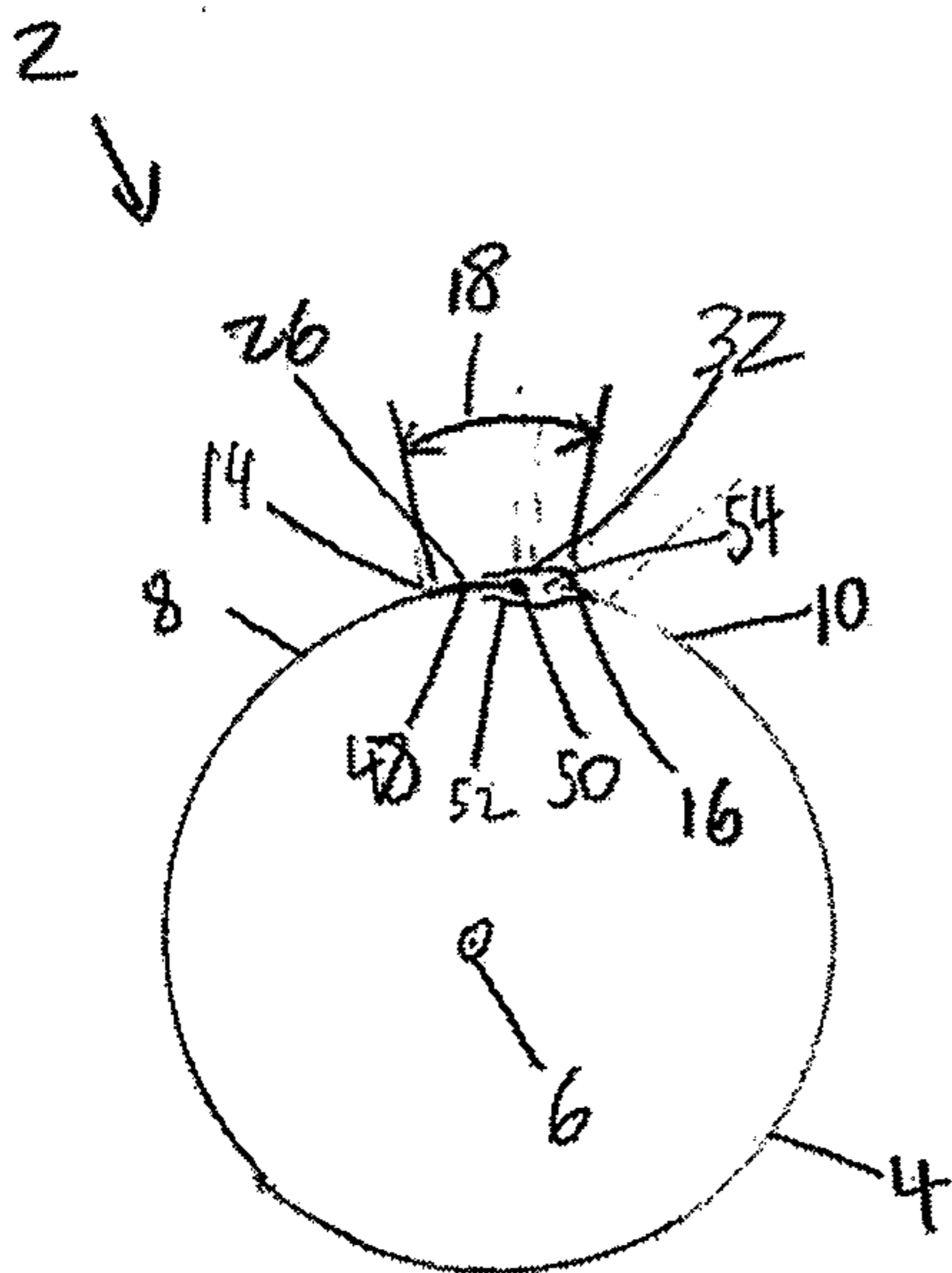

FIG. 7

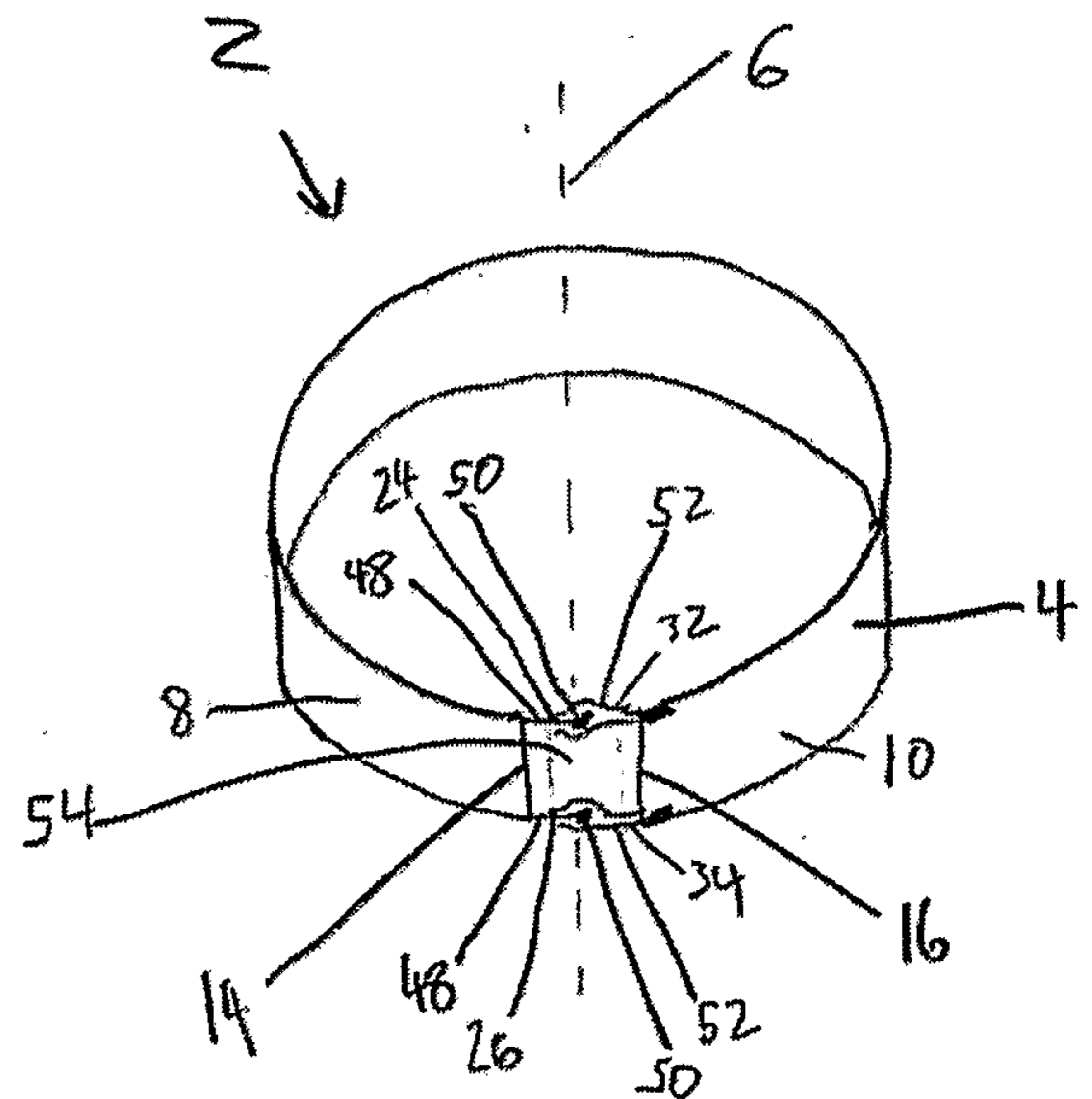

FIG. 8

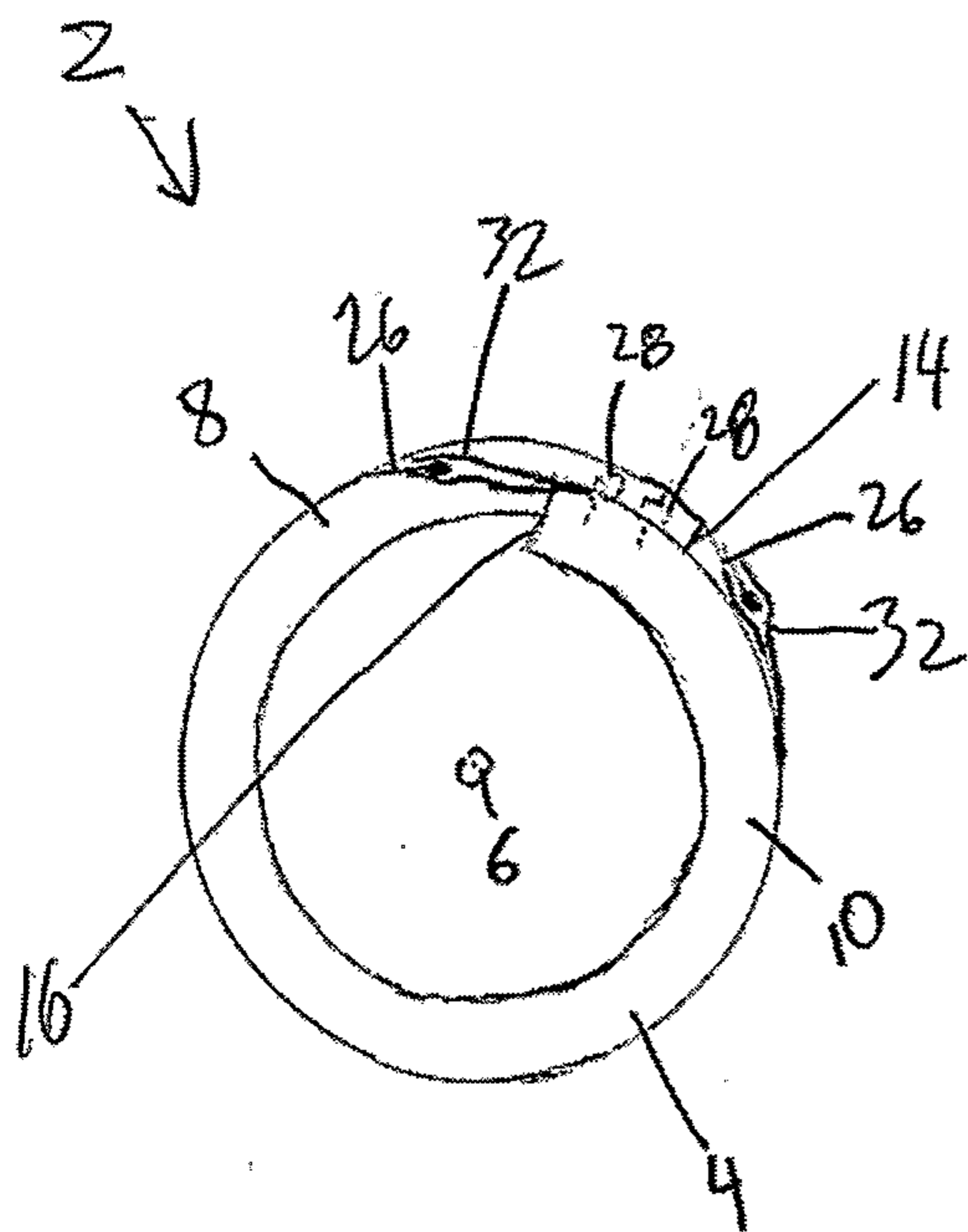

FIG. 9

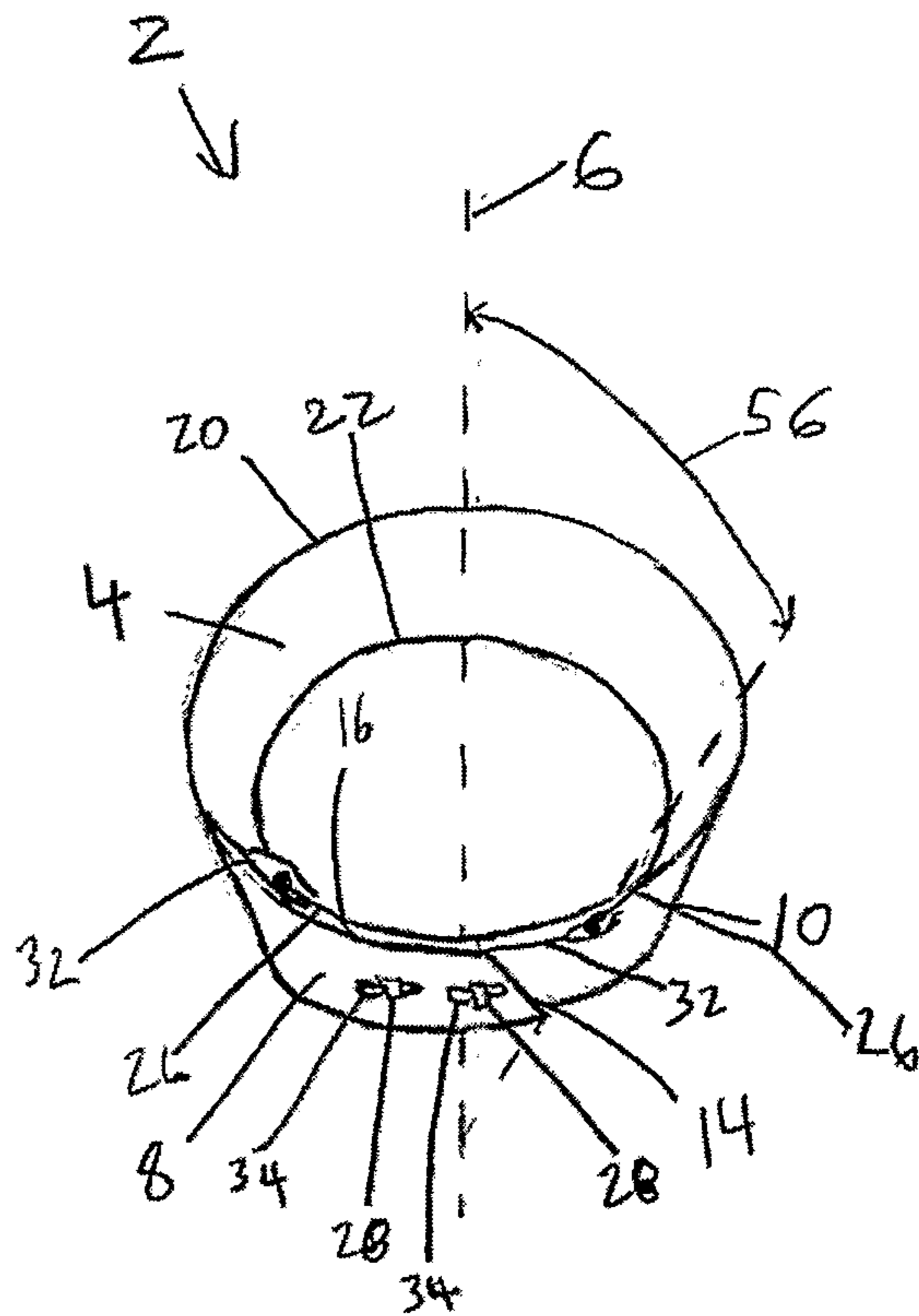

FIG. 10

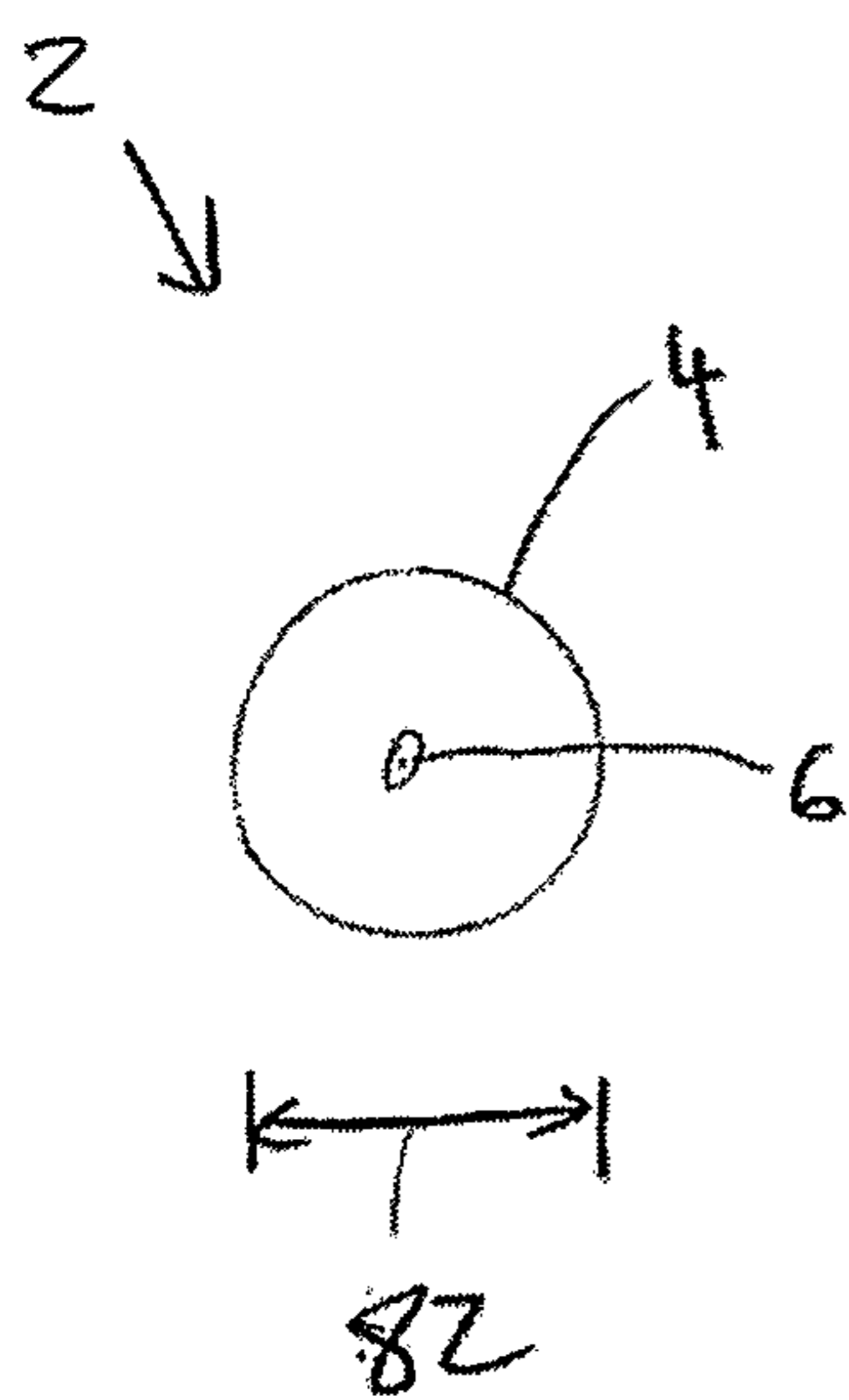

FIG. 16

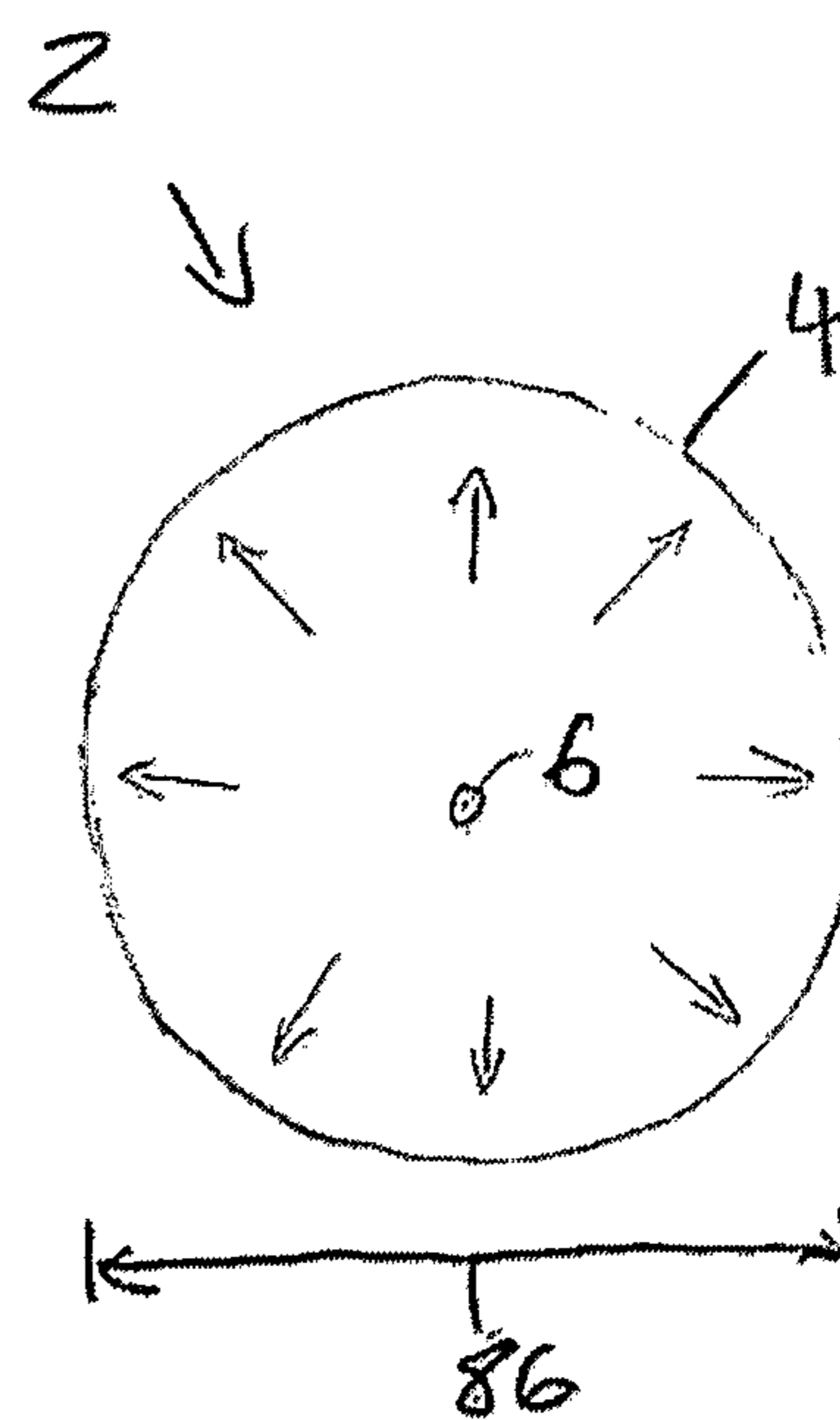

FIG. 19



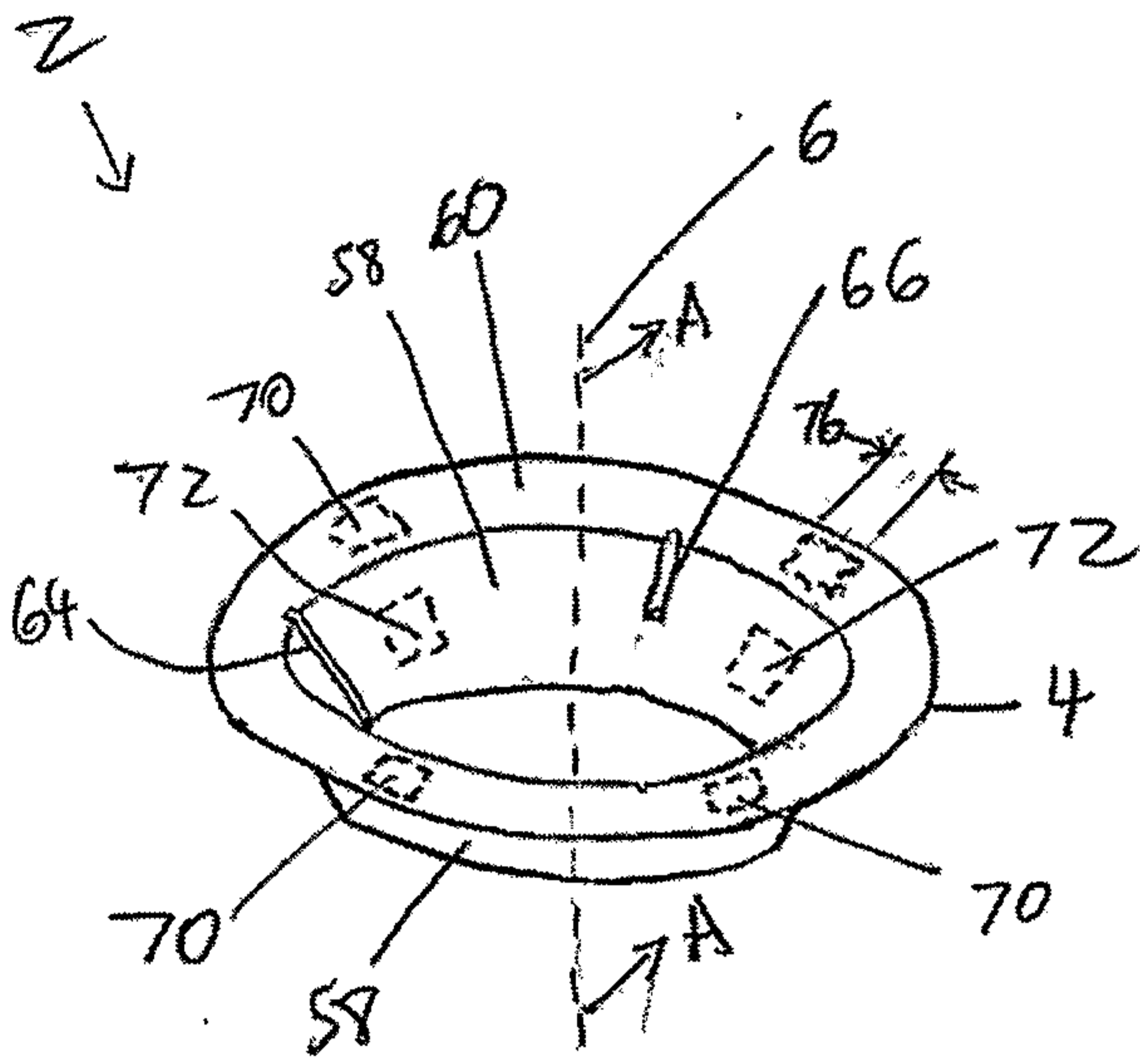

FIG. 11

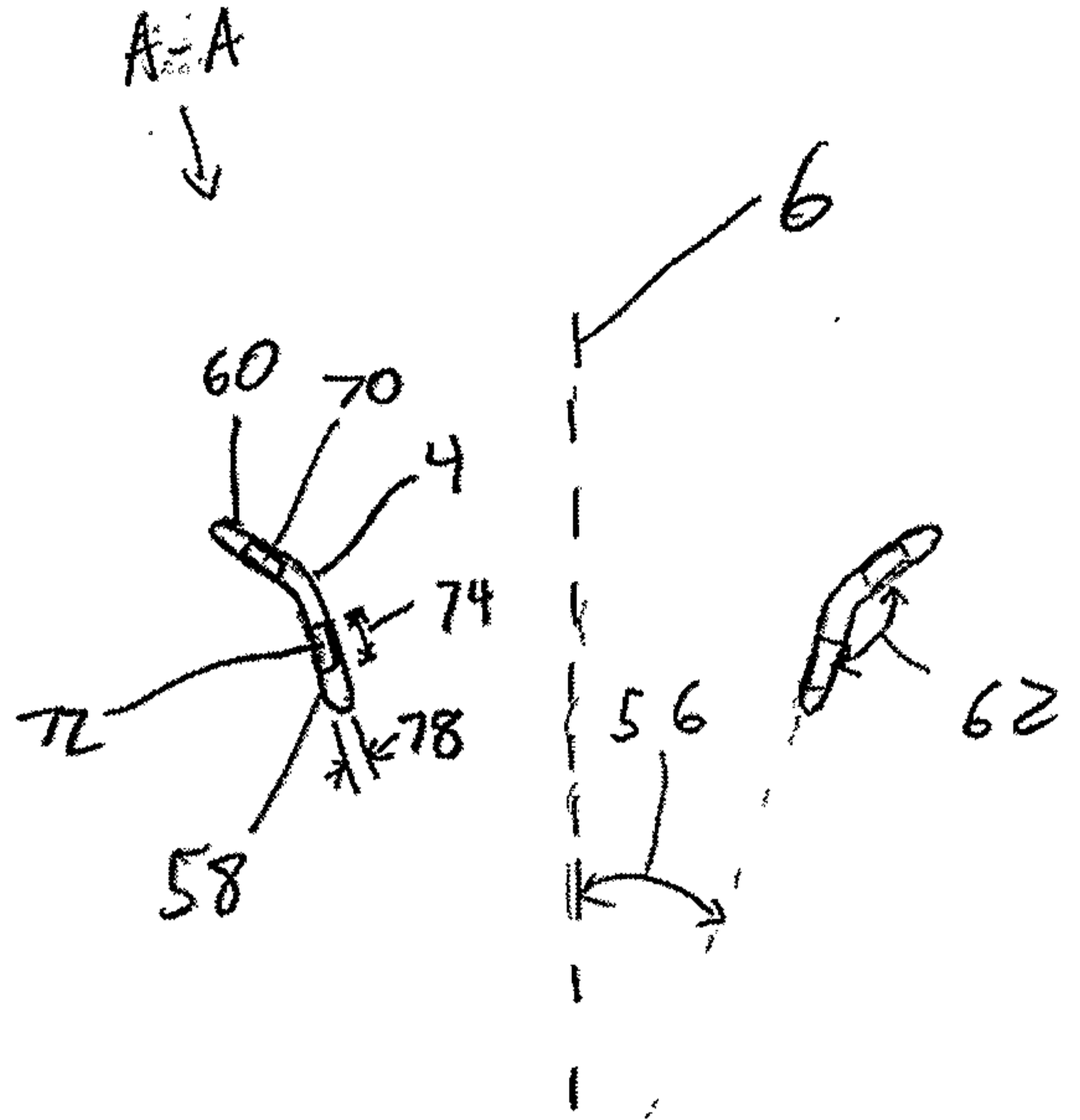

FIG. 12

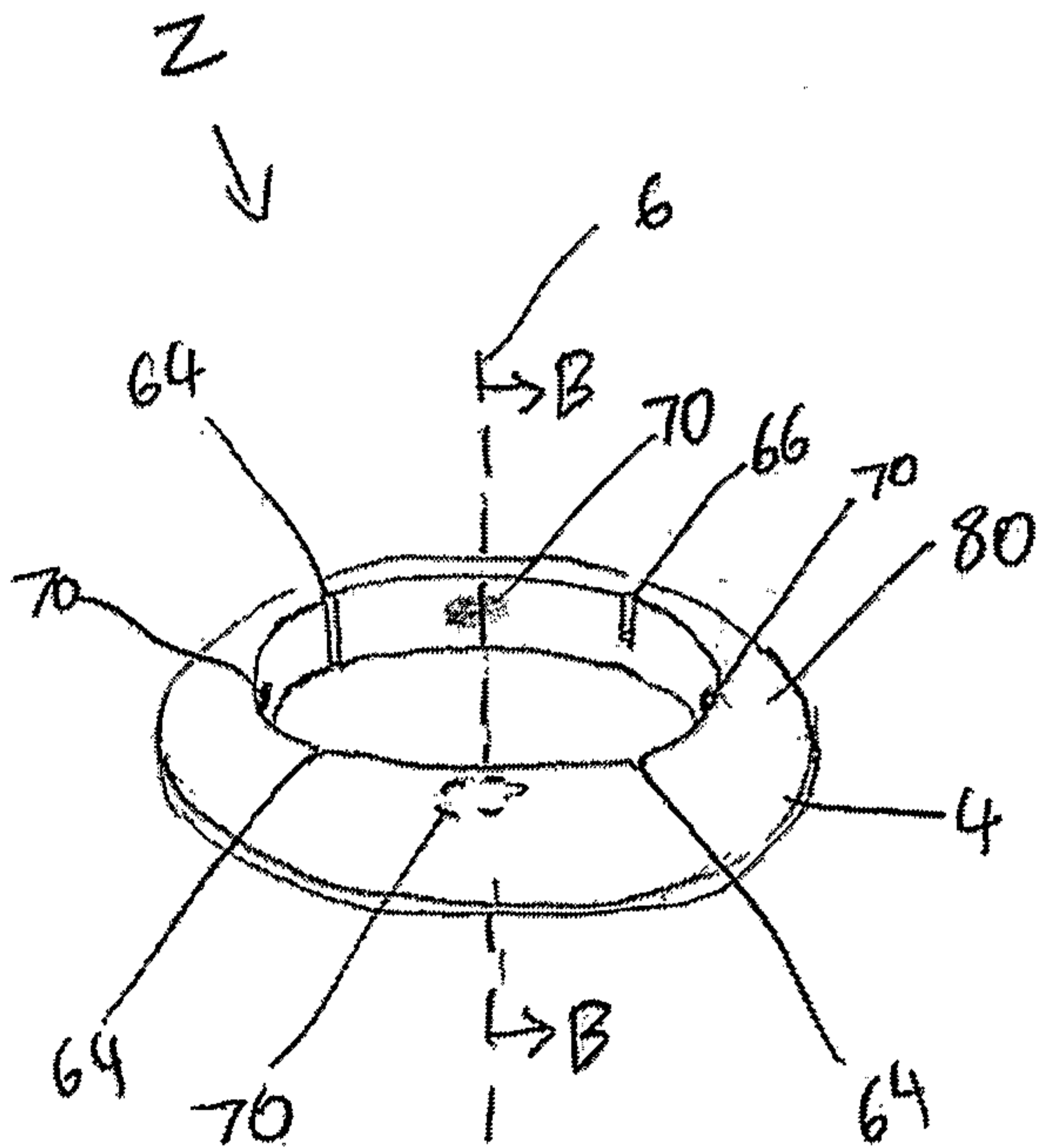

FIG. 13

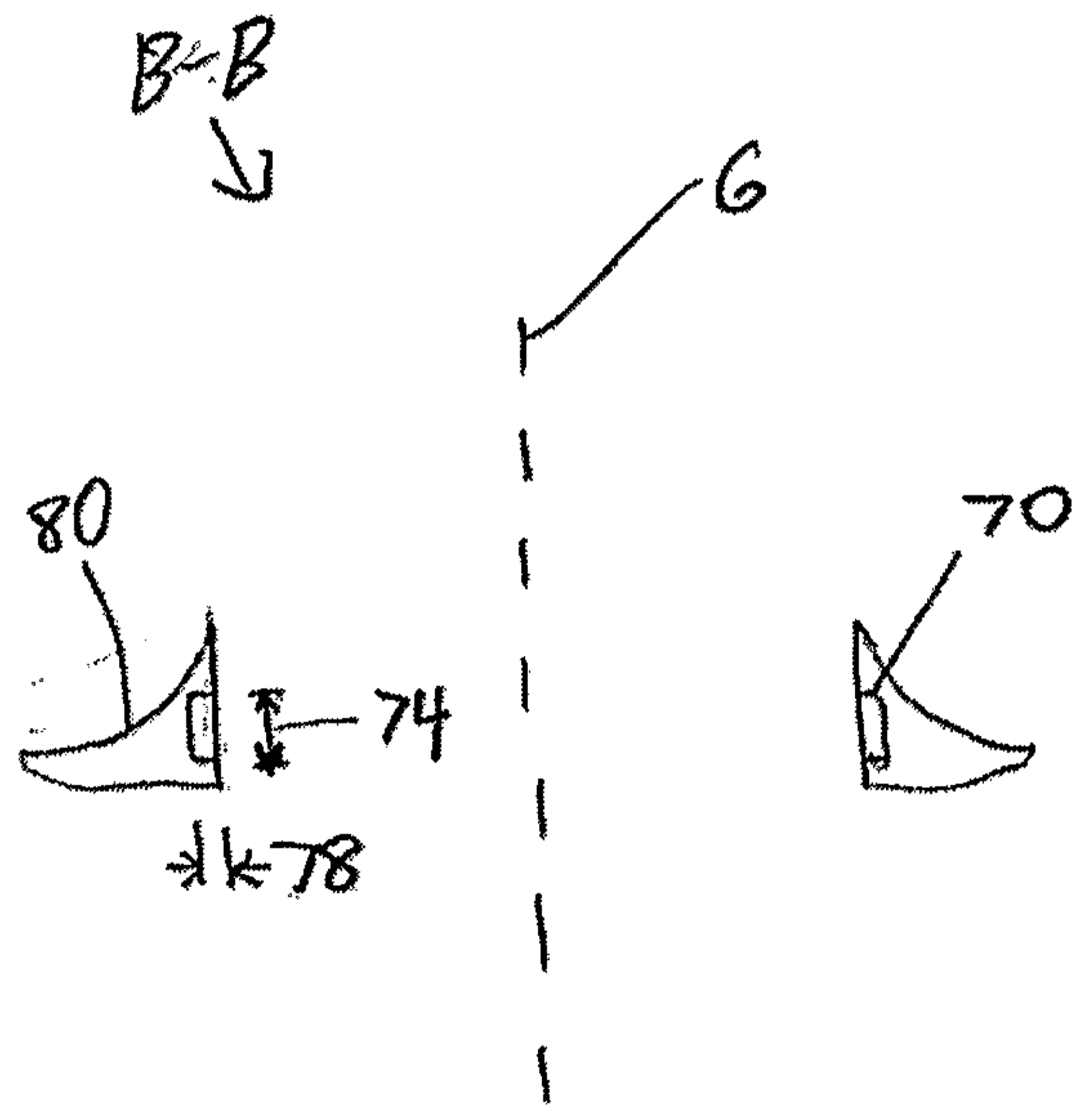

FIG. 14

2  
↓

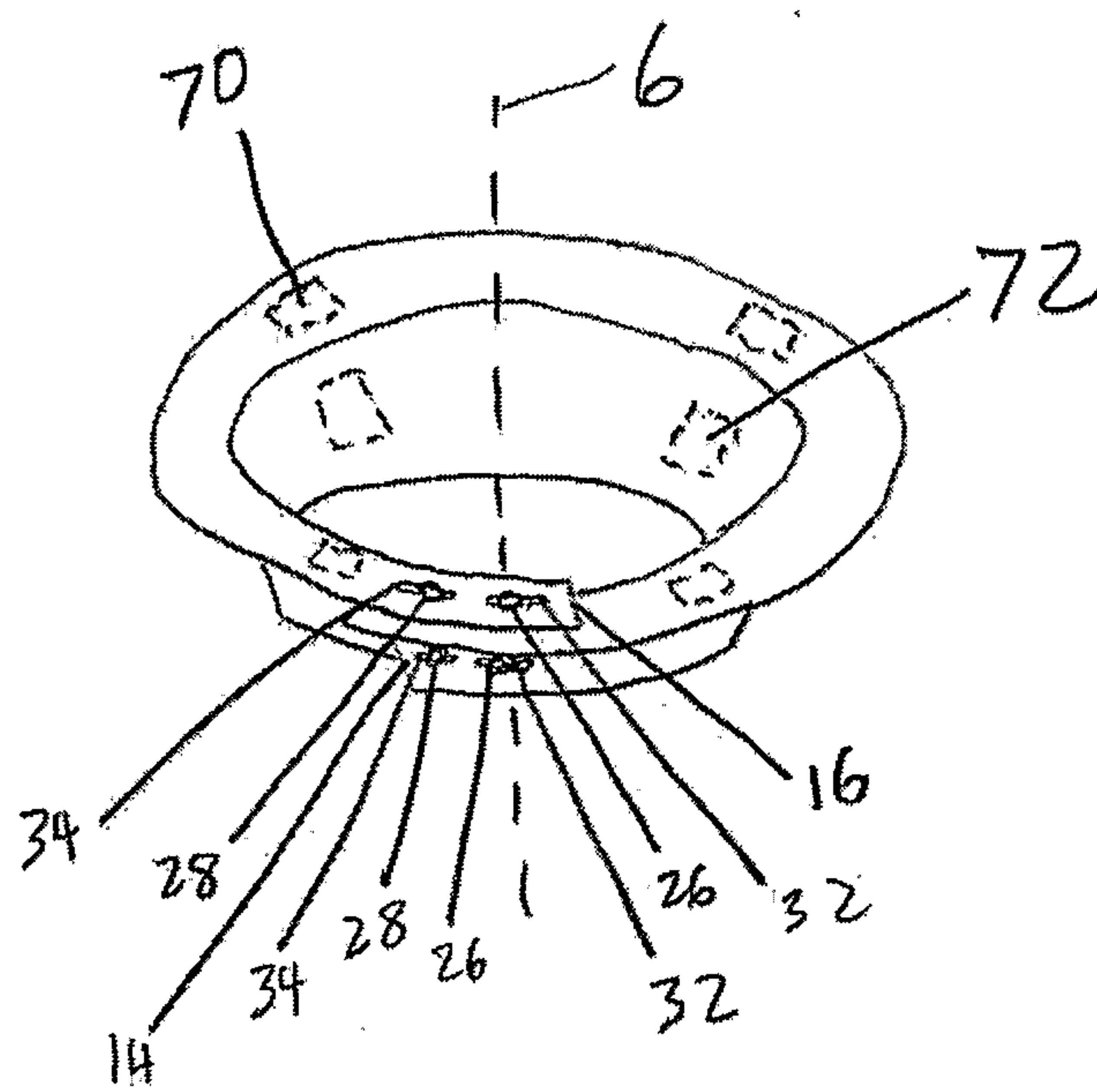

Fig. 15

Z ↓

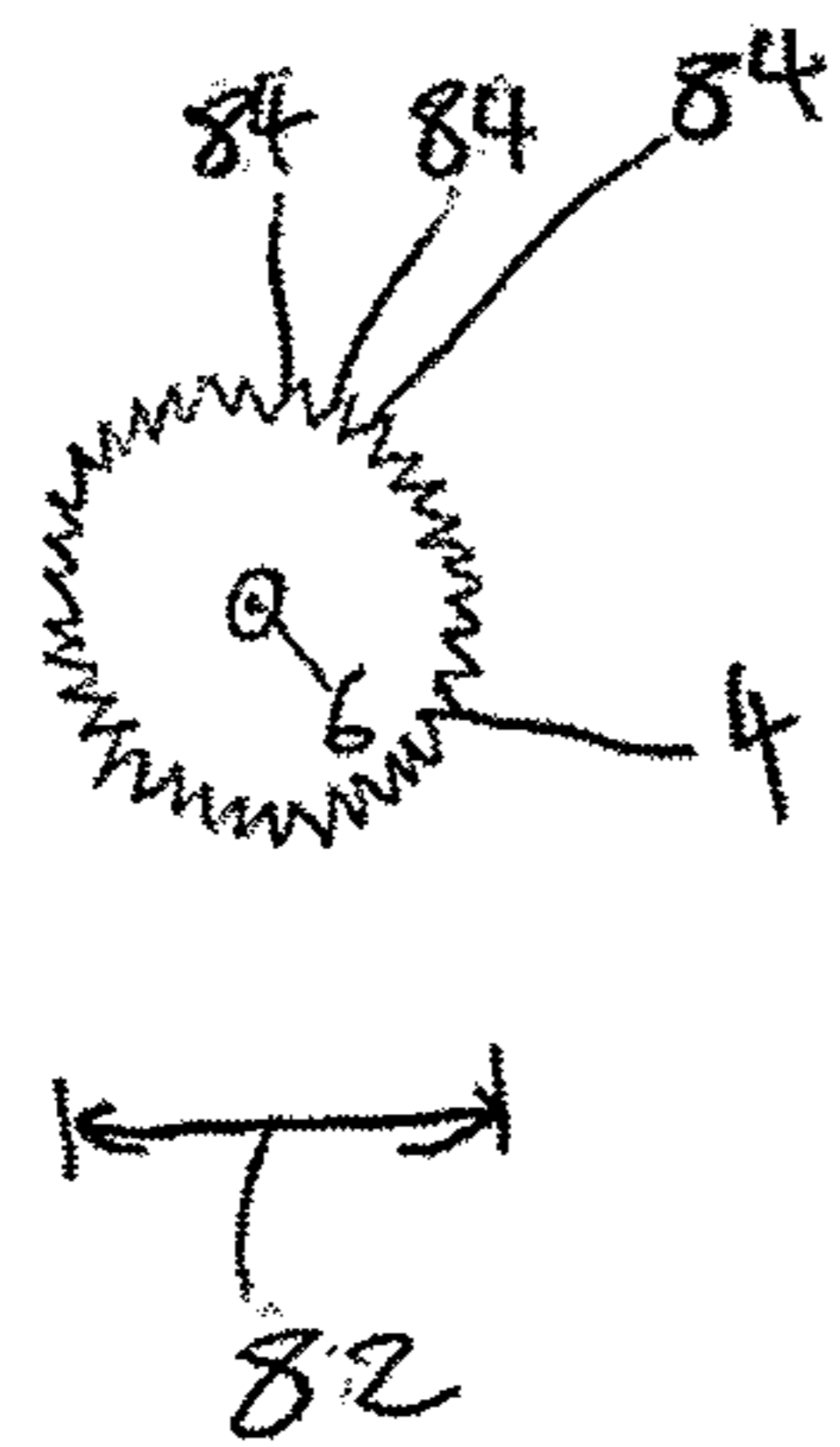

FIG. 17.

Z ↓

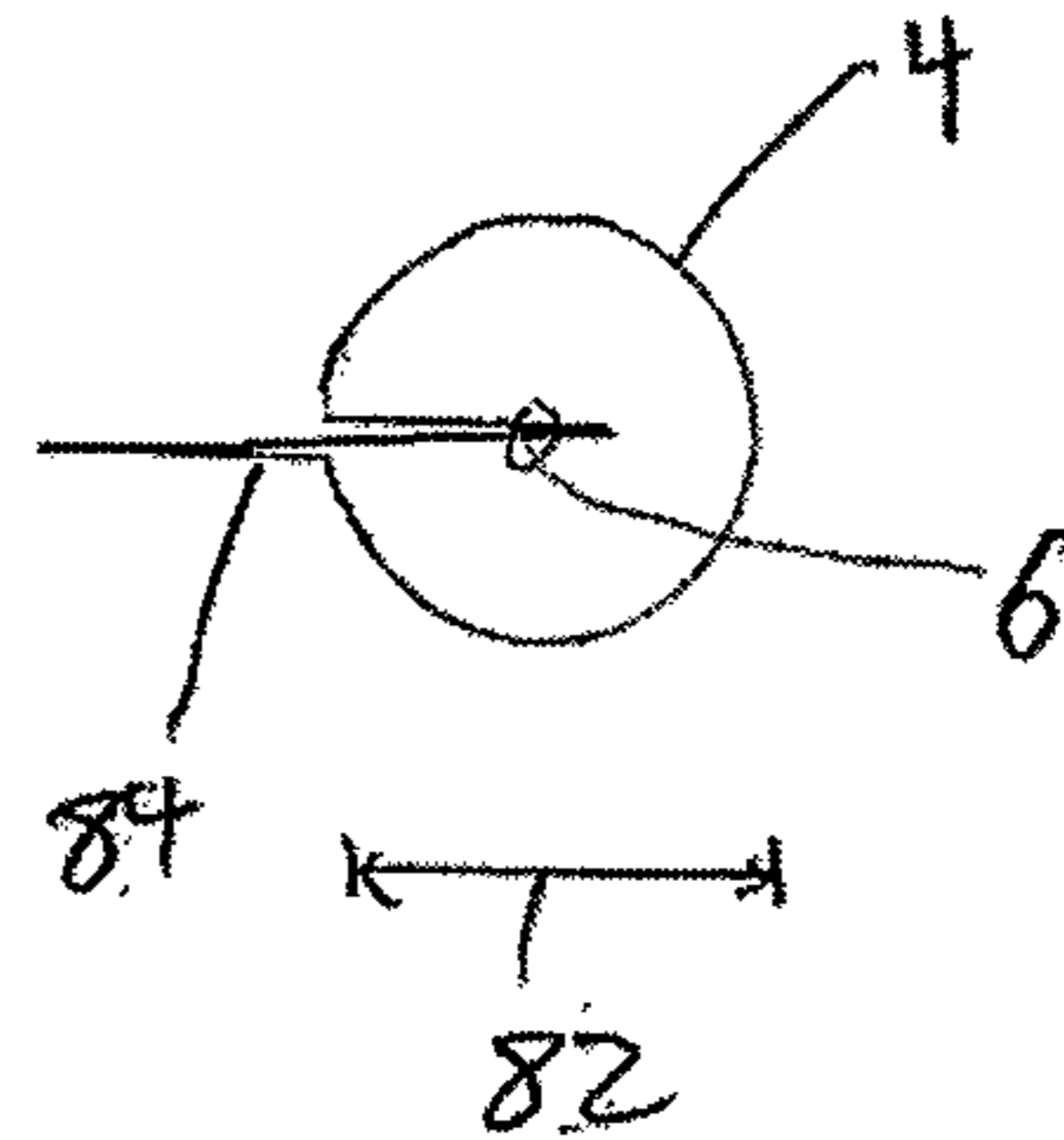

FIG. 18.

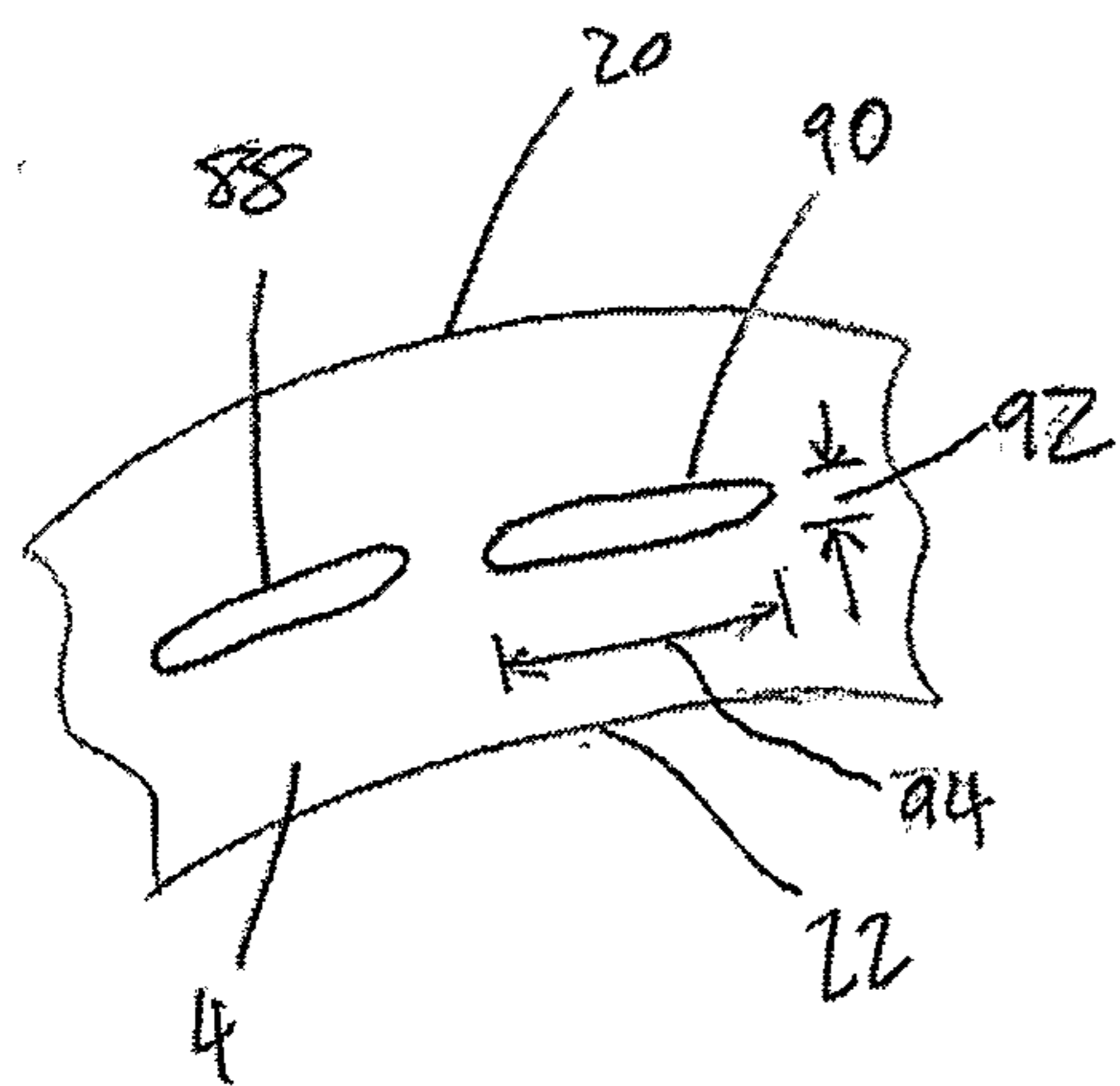

FIG. 20

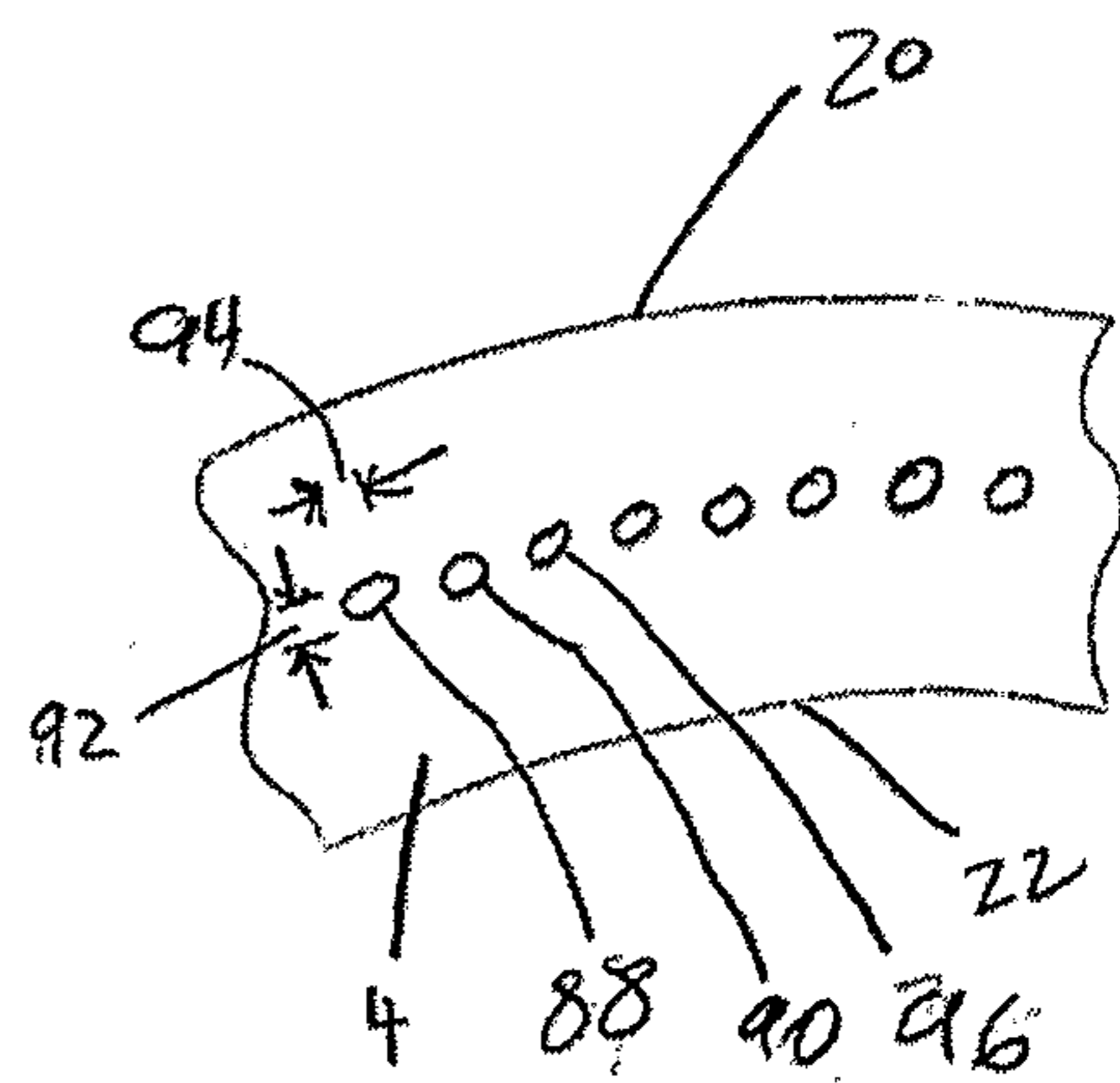

FIG. 21

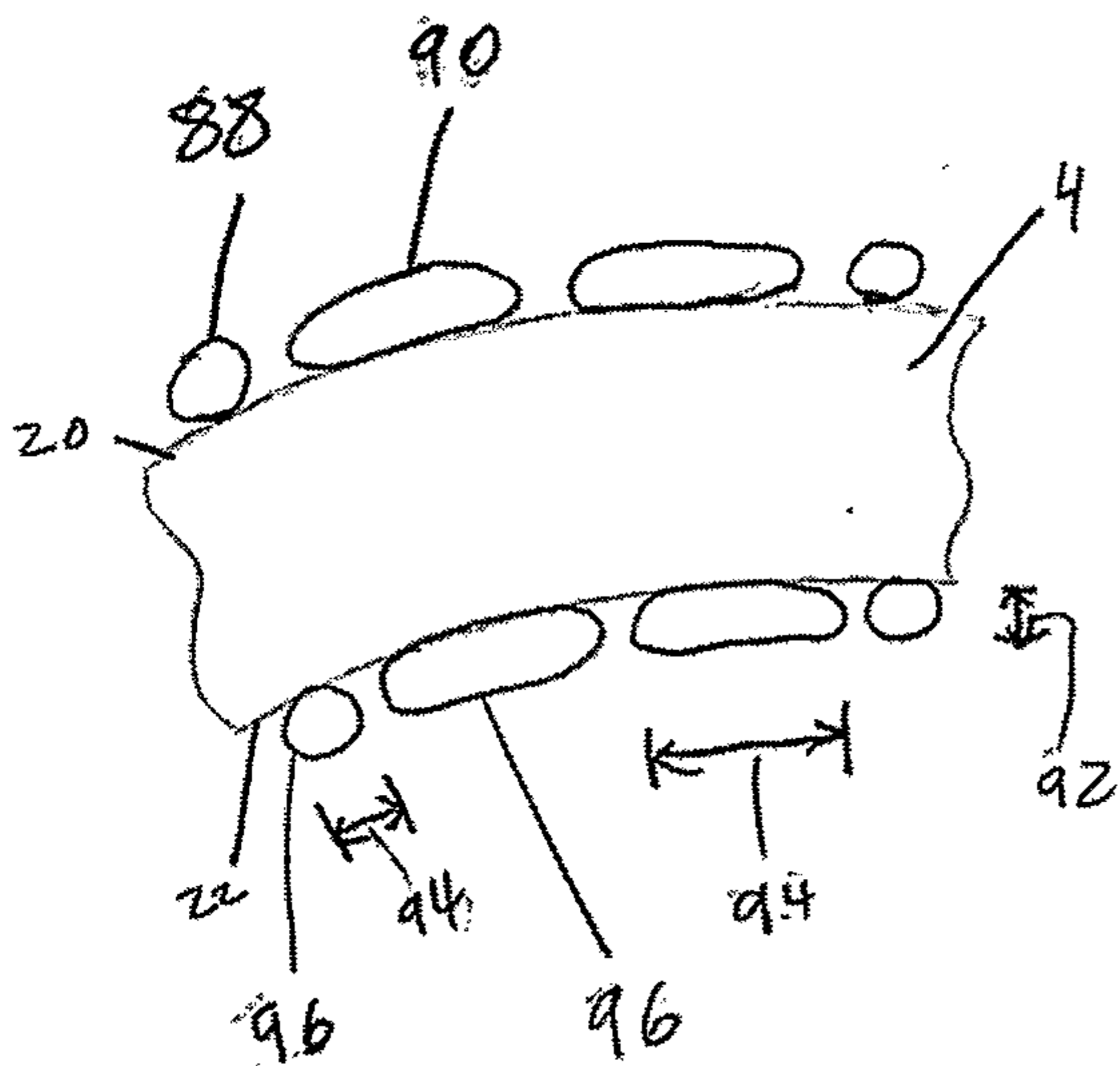

FIG. 22

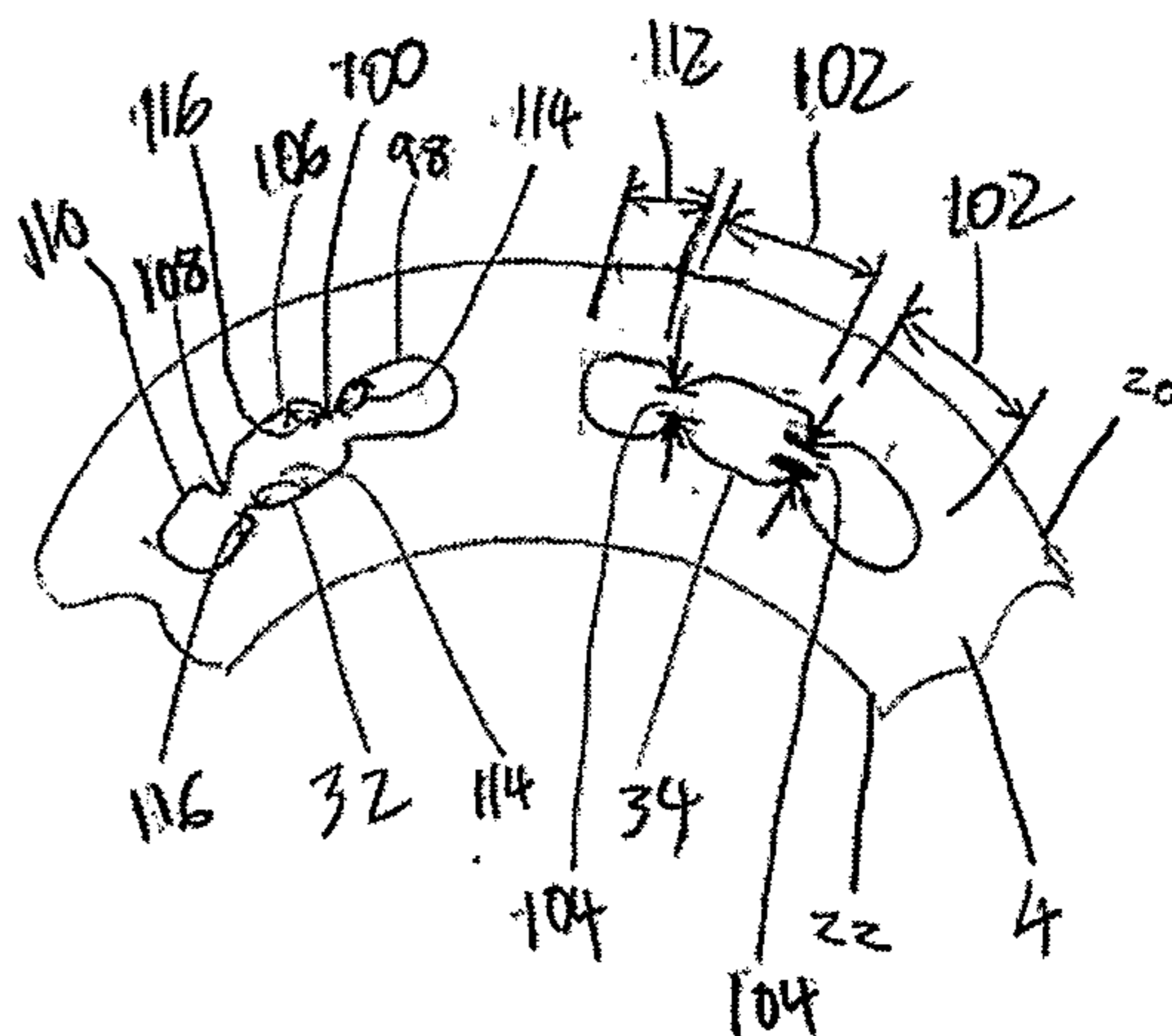

FIG. 23

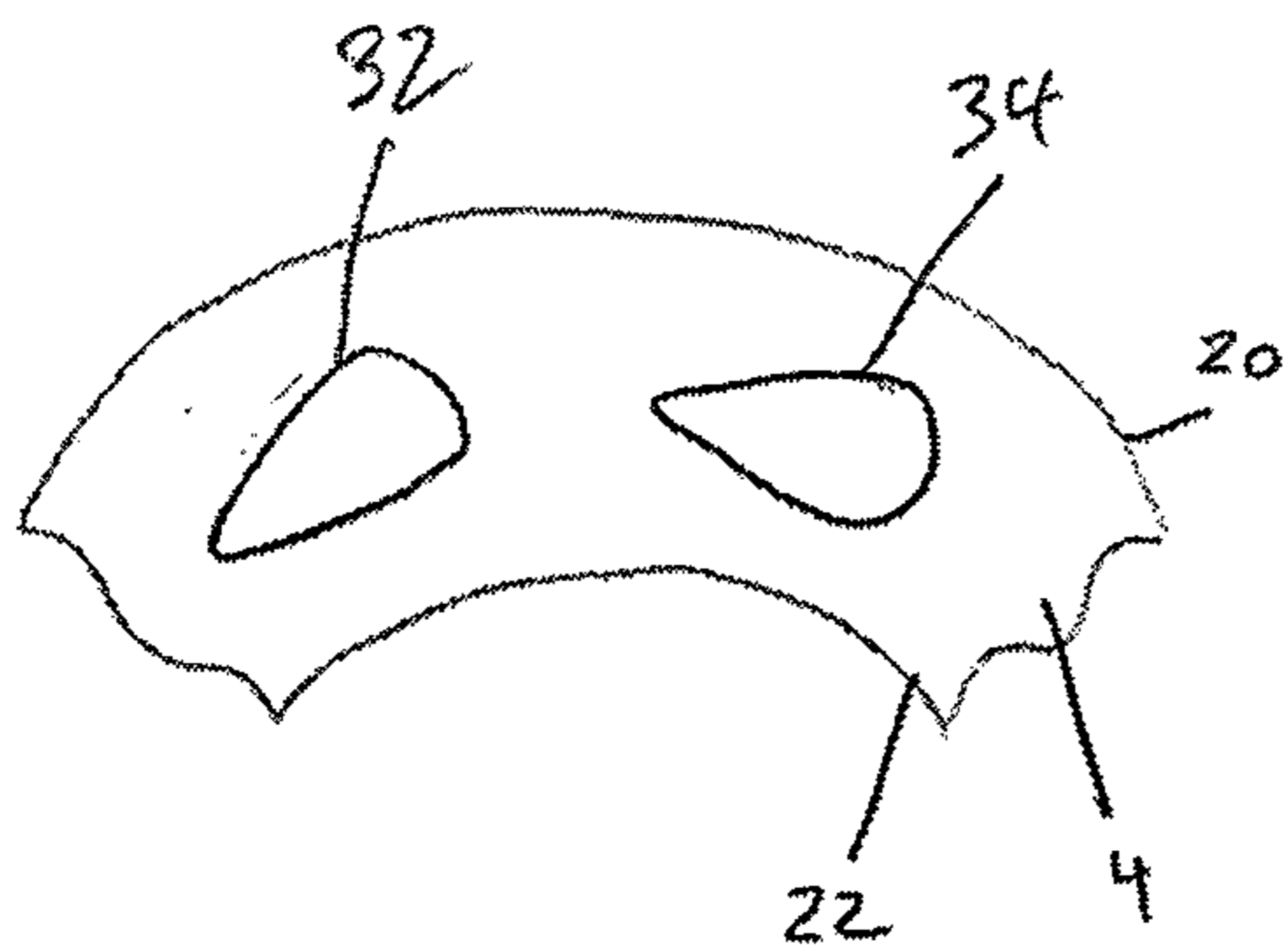

FIG. 24

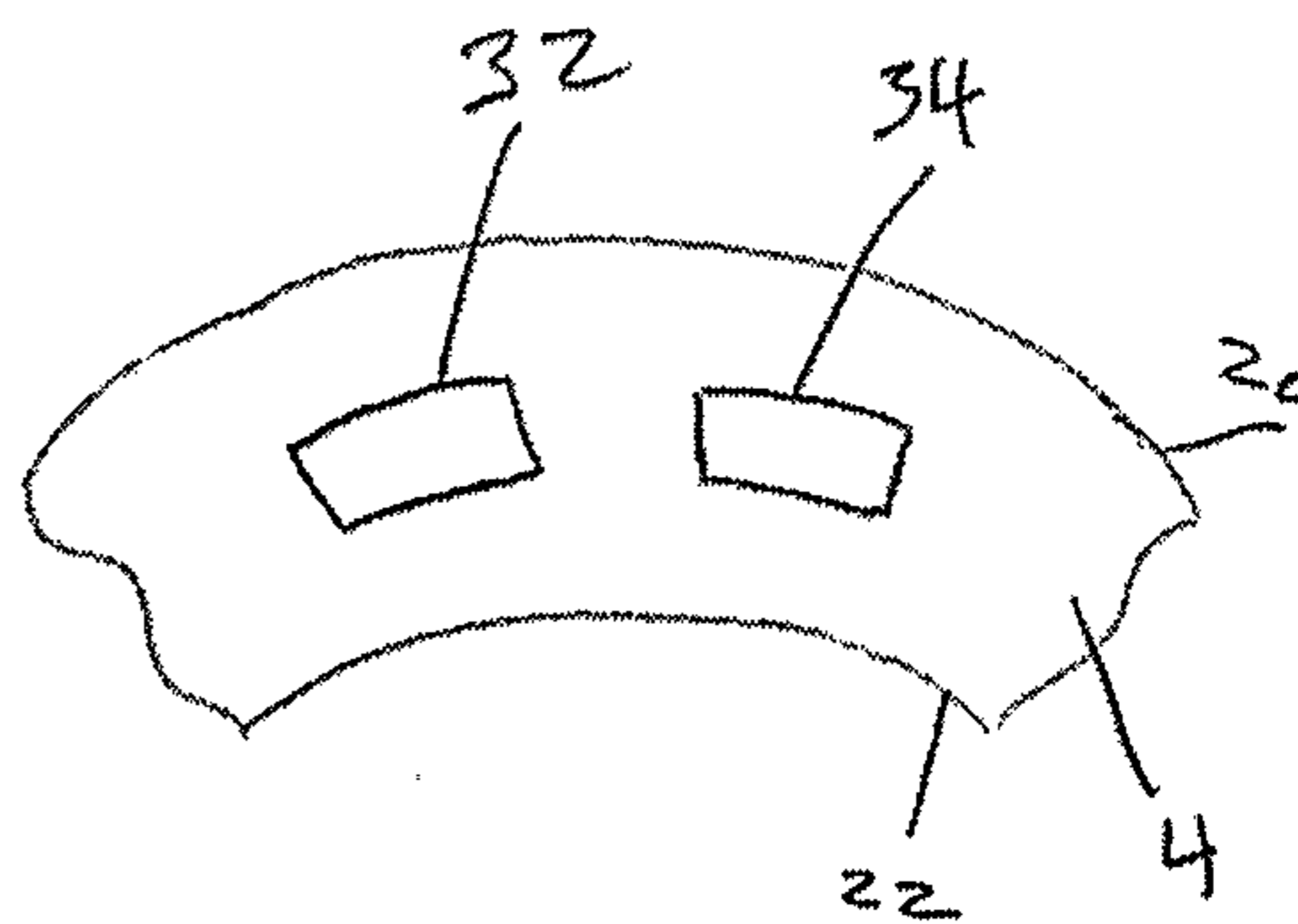

FIG. 25

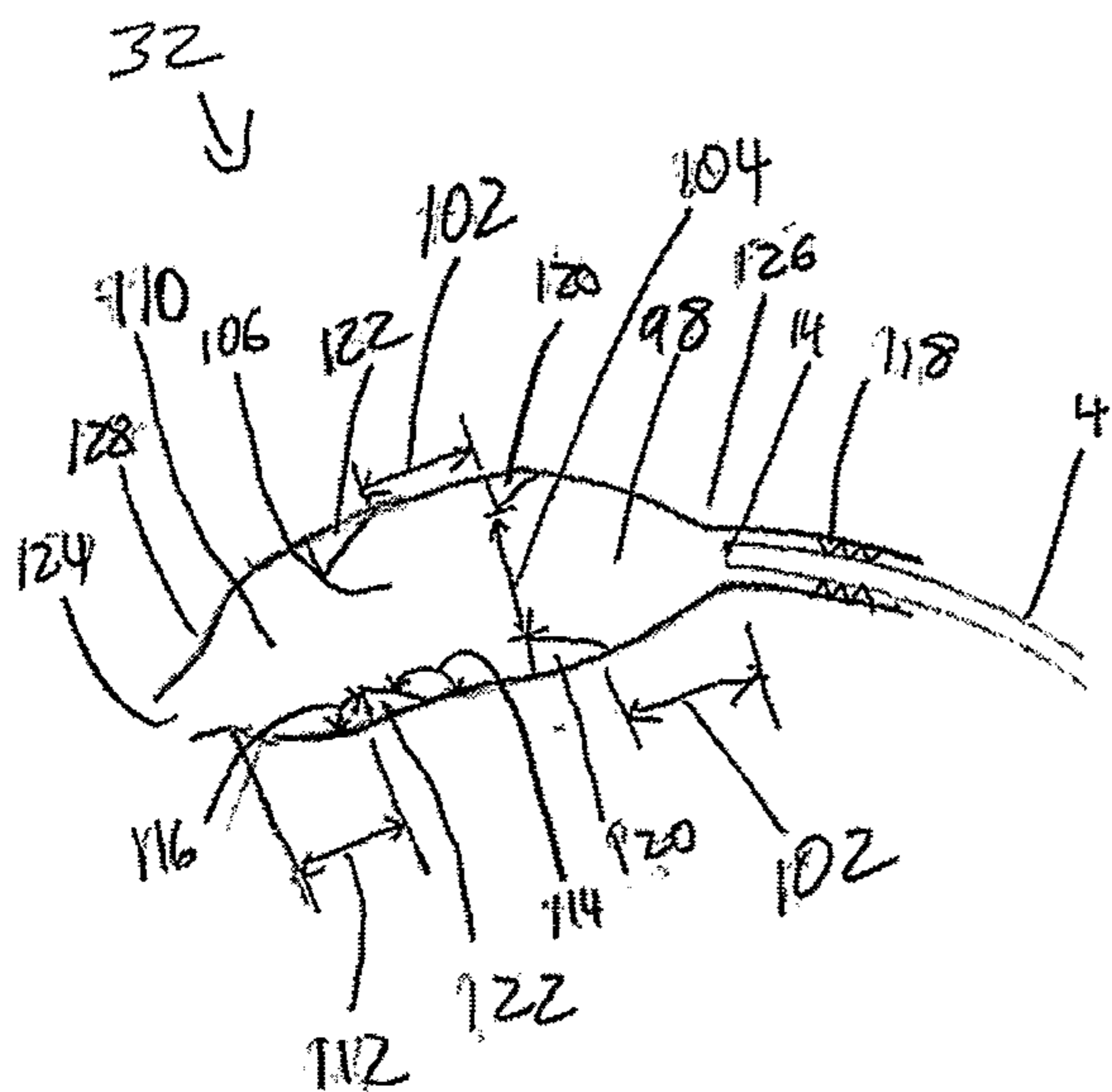

FIG. 26

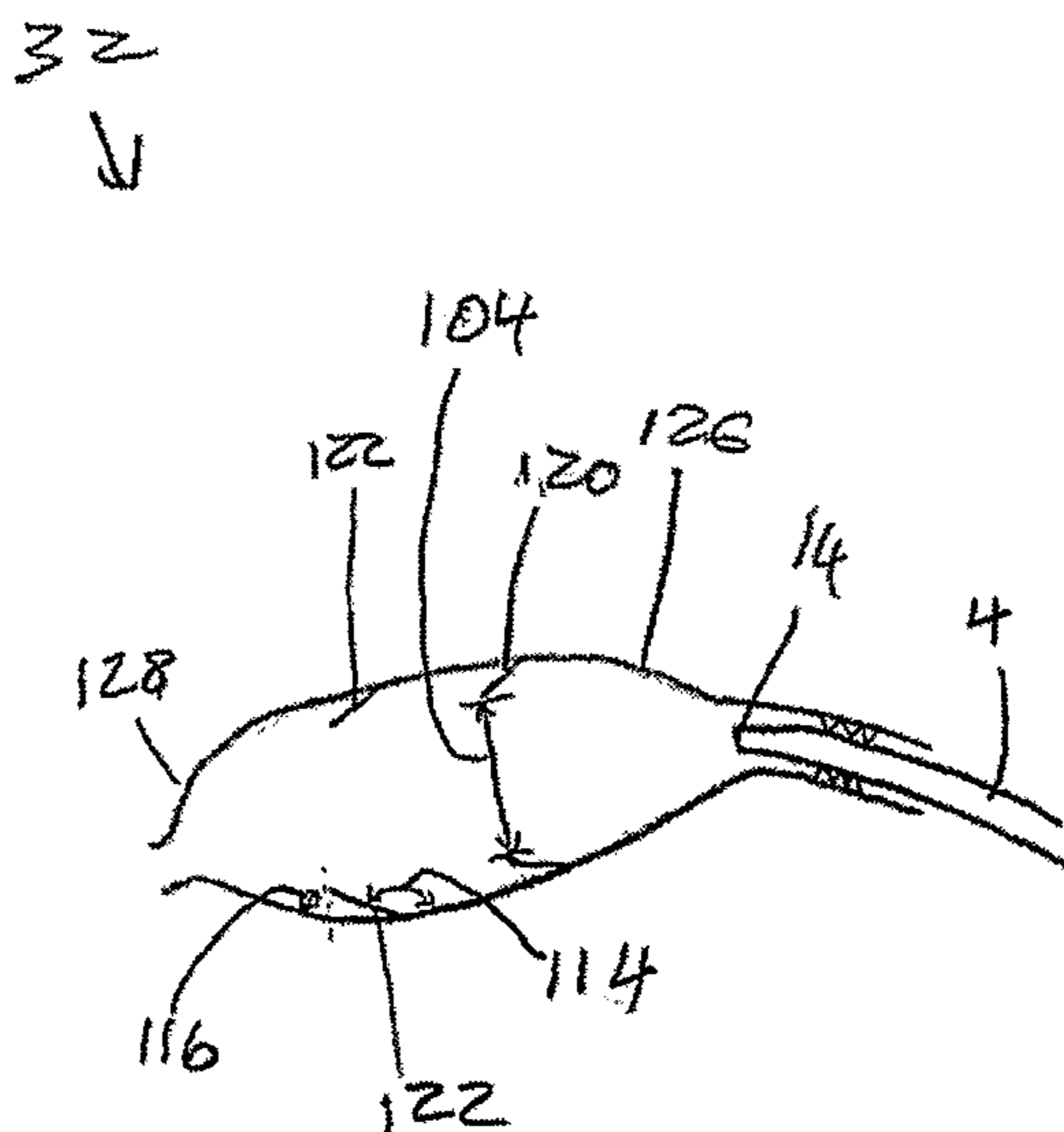

FIG. 27

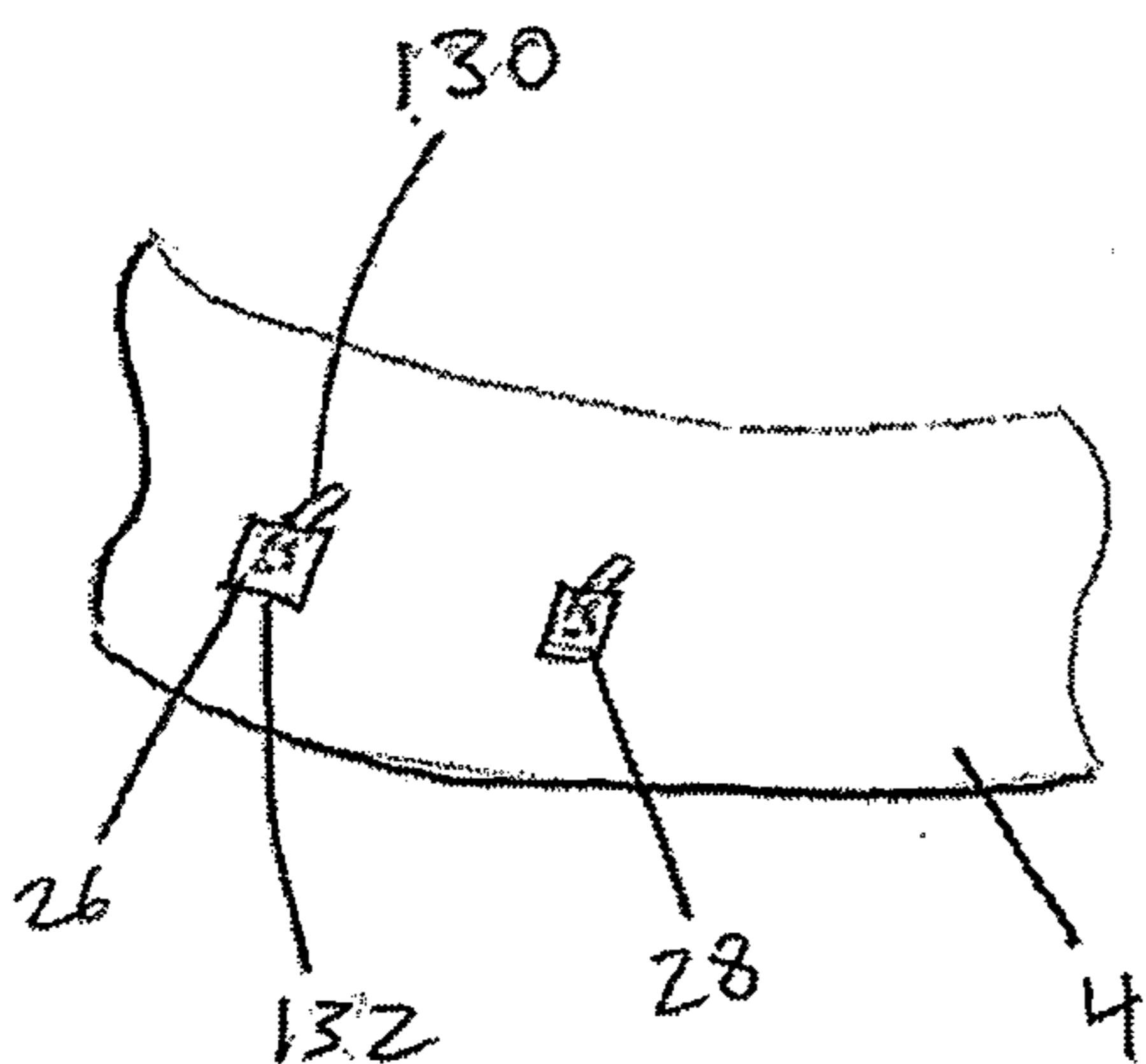

FIG. 28

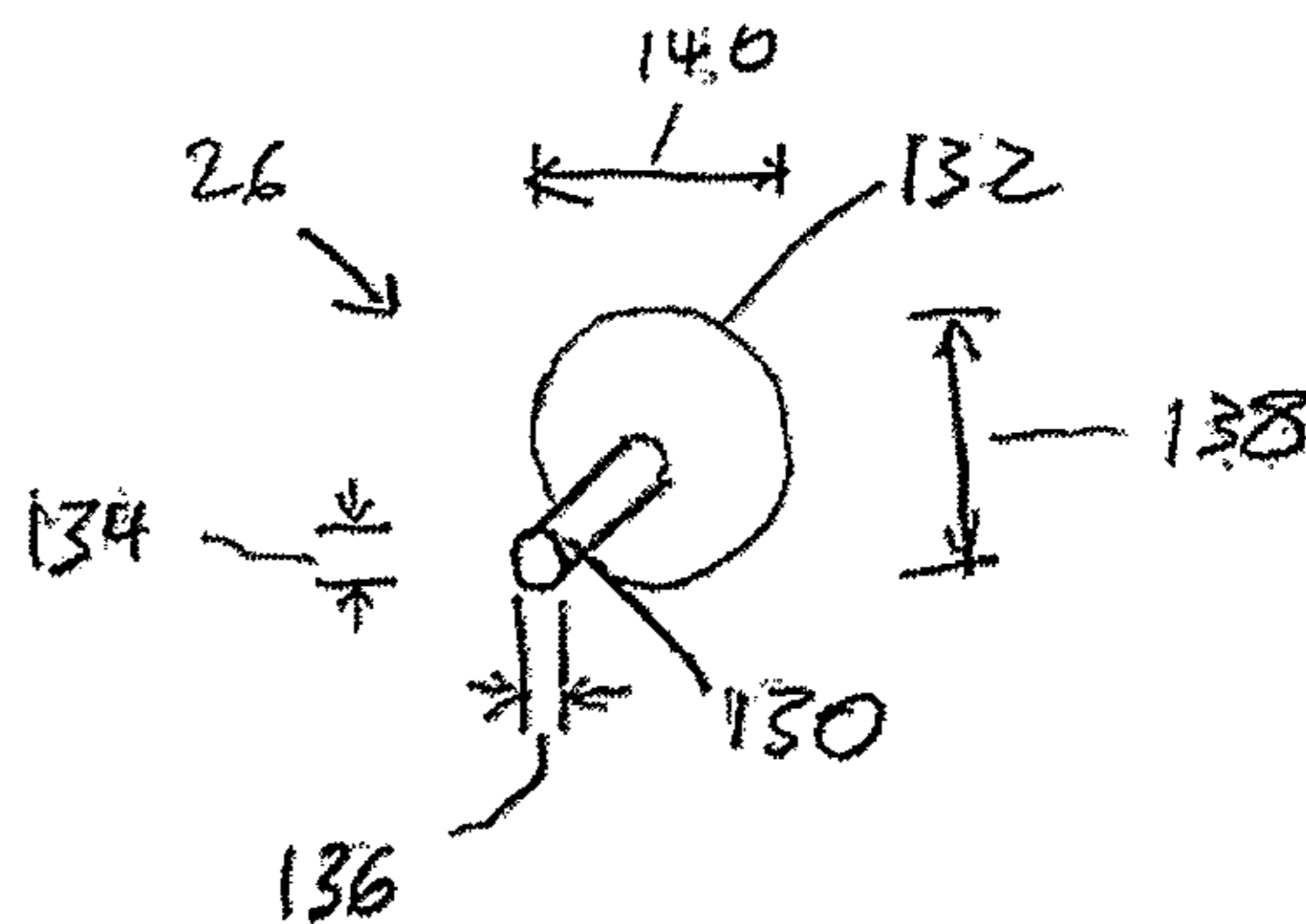

FIG. 29

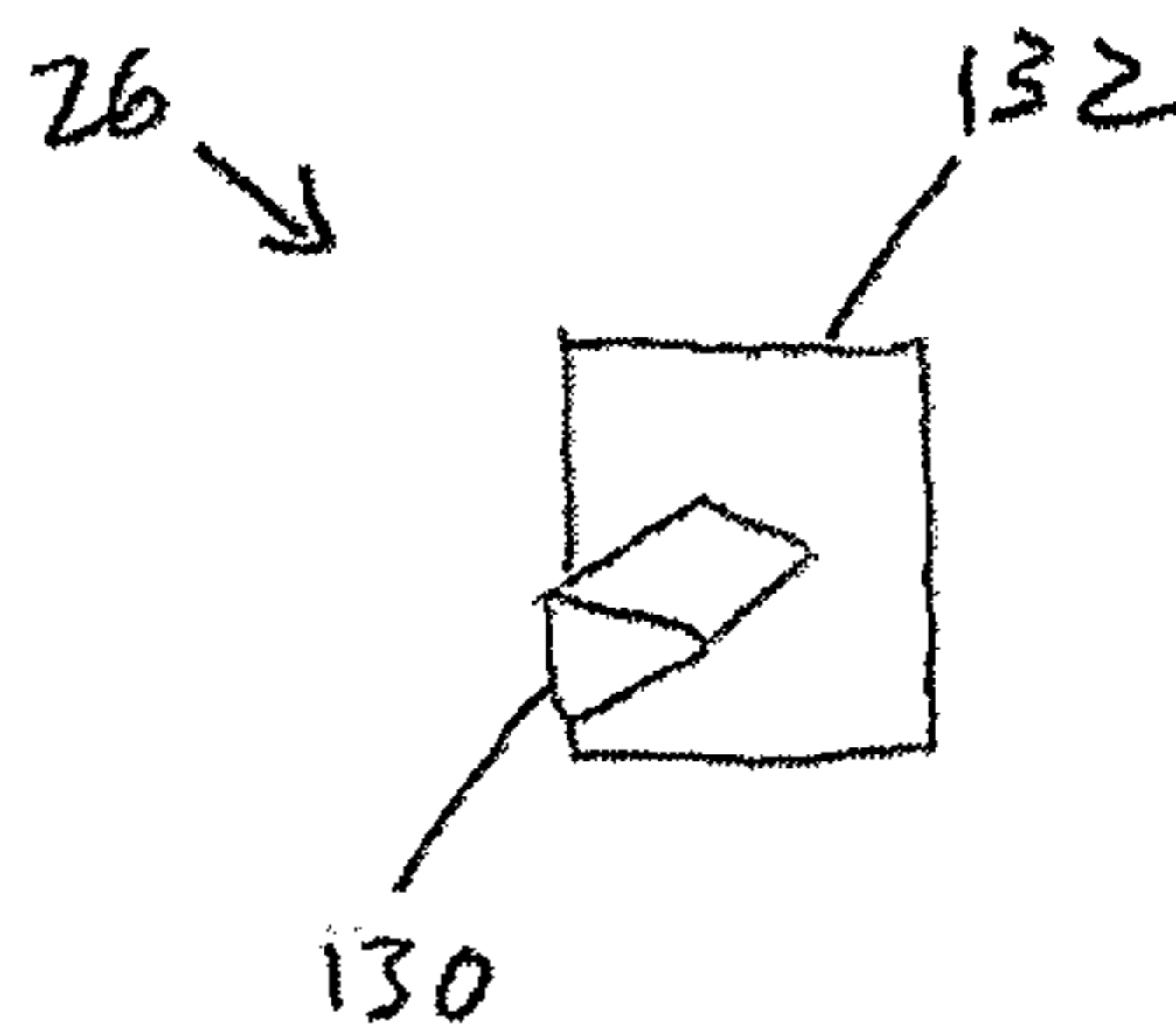

FIG. 30

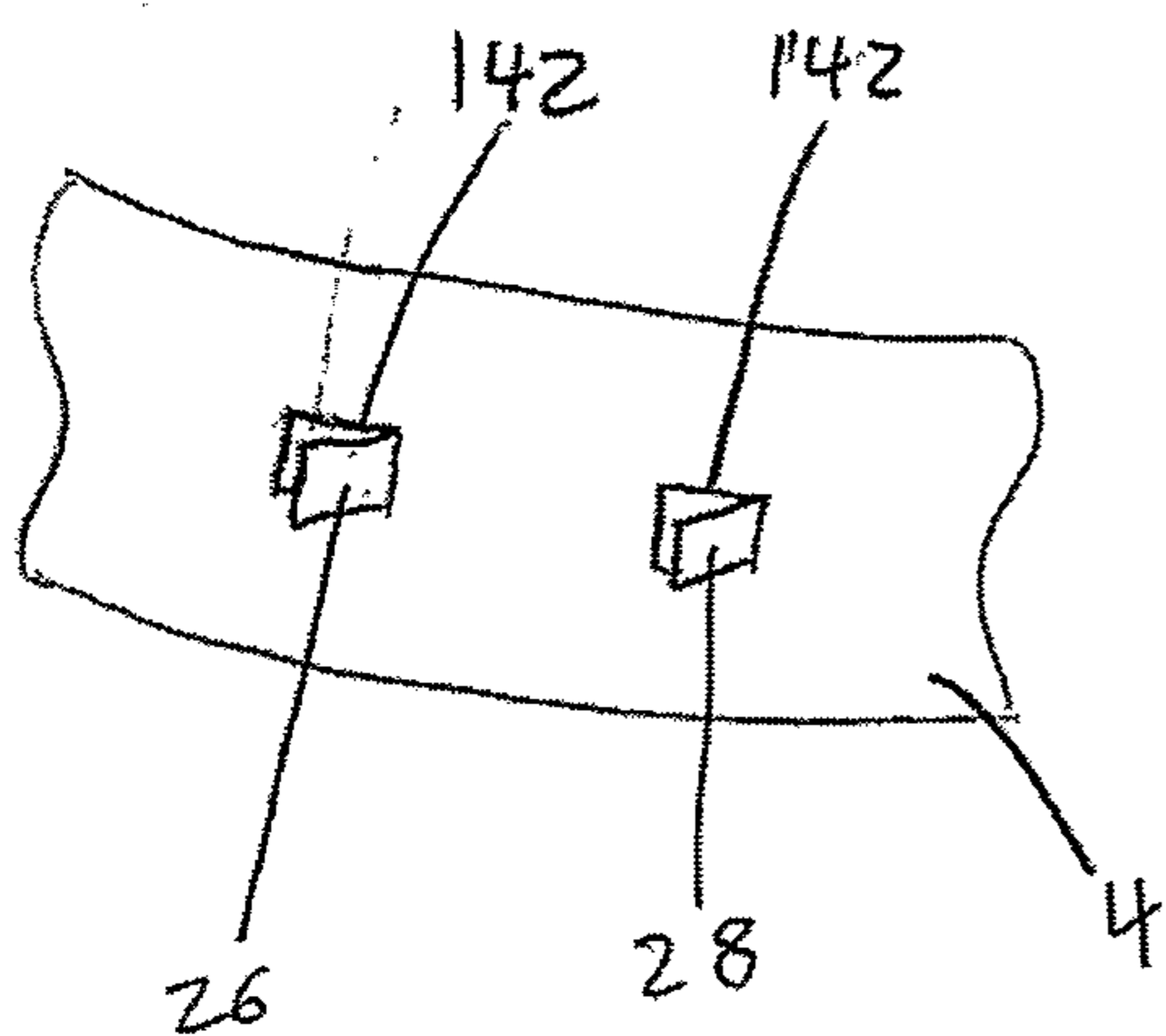

FIG. 36

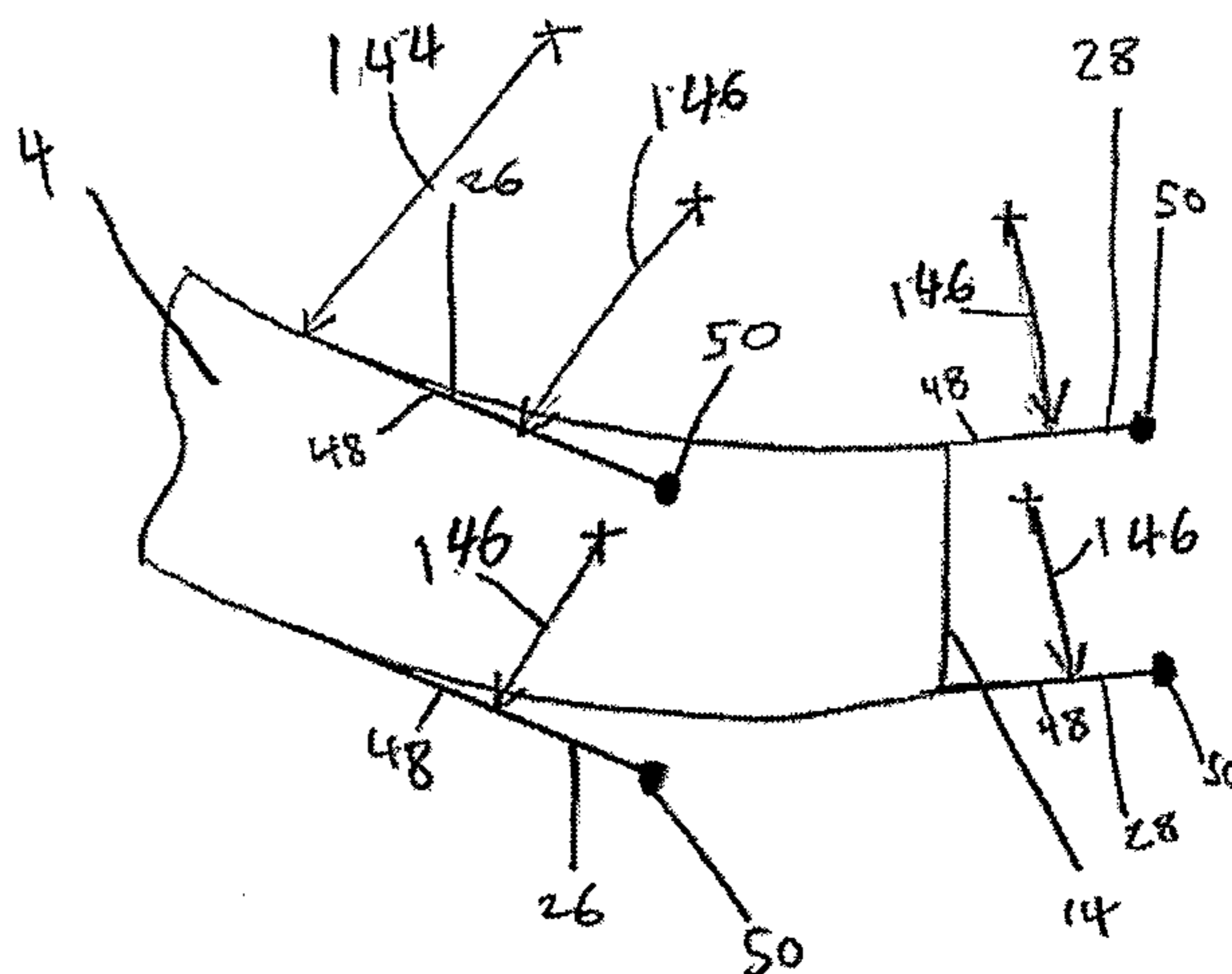

FIG. 37

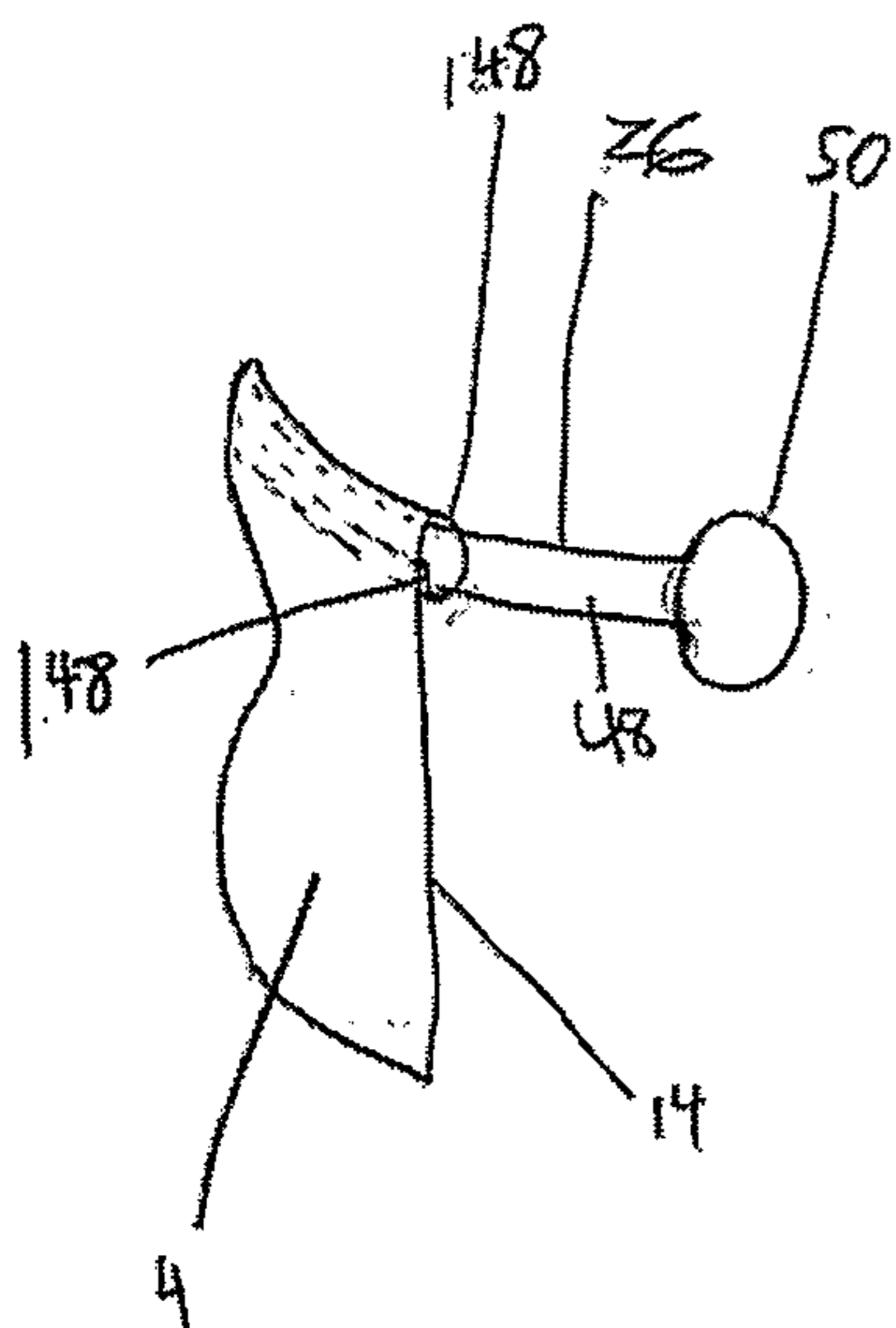

FIG. 38

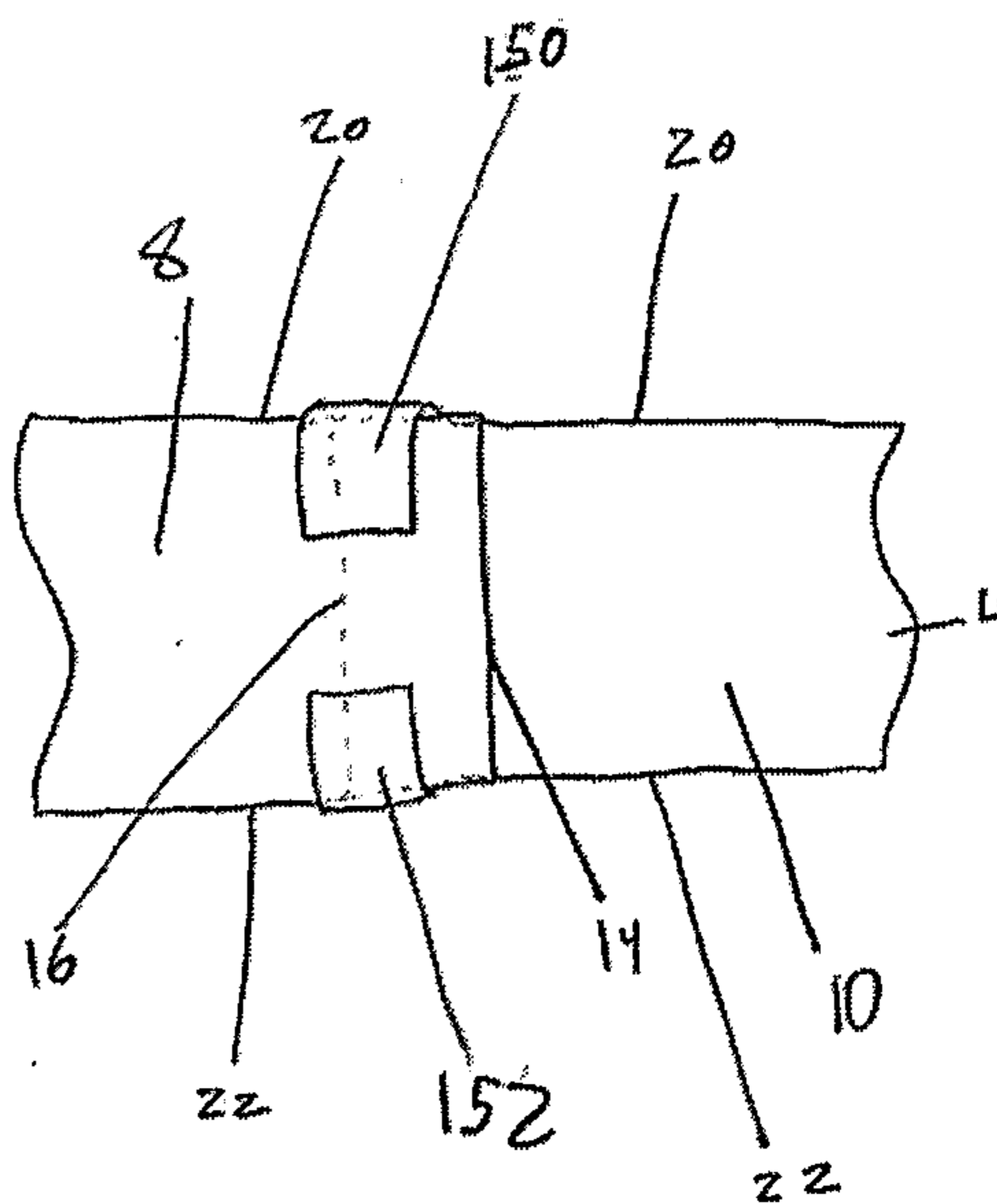

FIG. 39



FIG. 35



FIG. 36

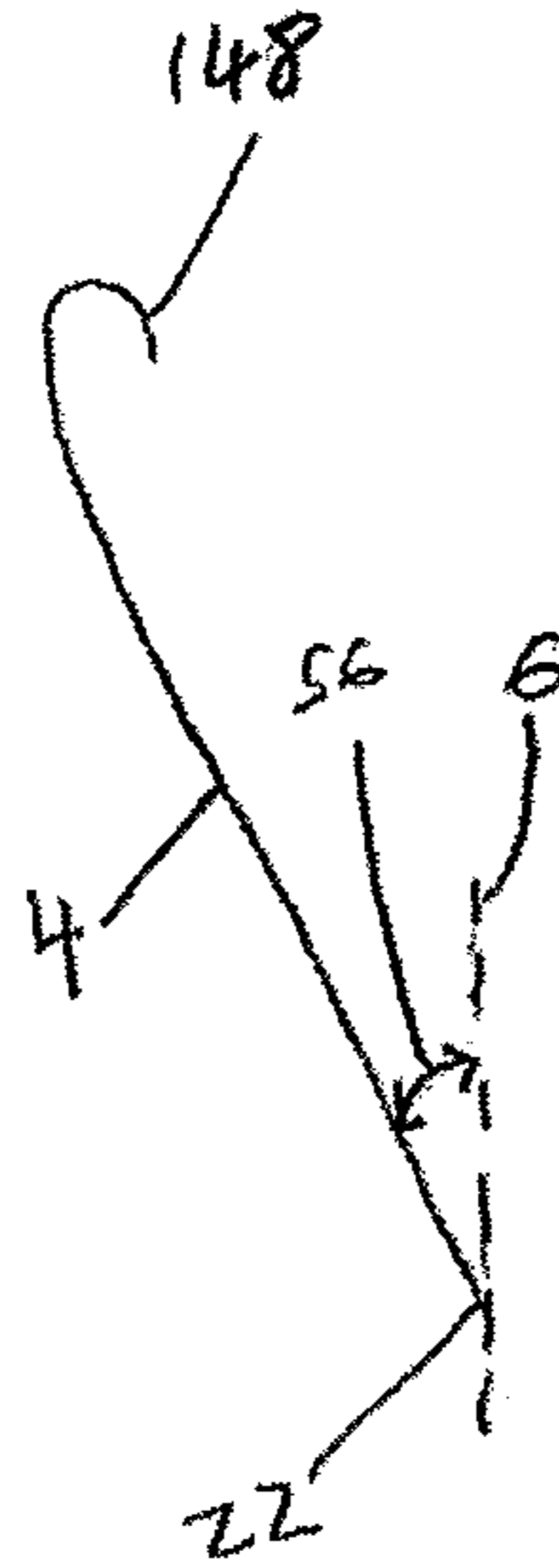

FIG. 37

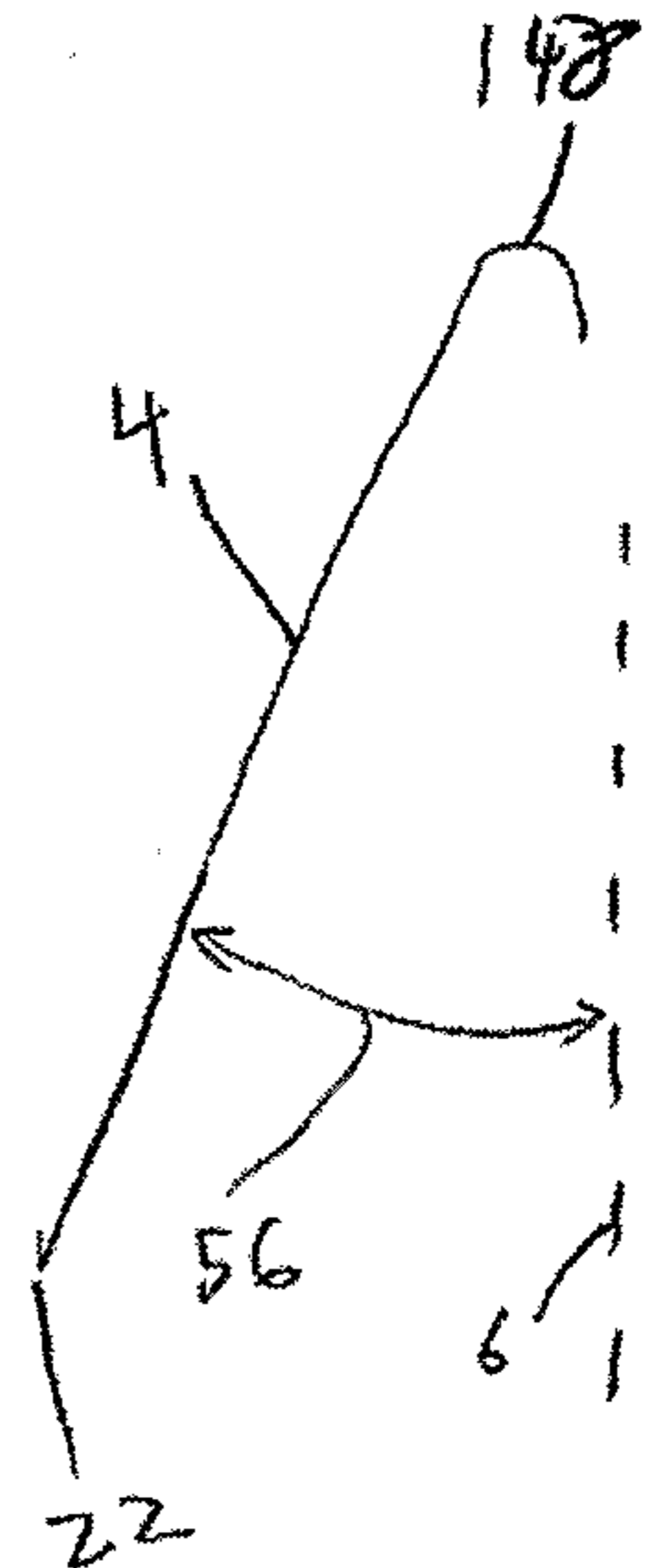

FIG. 38

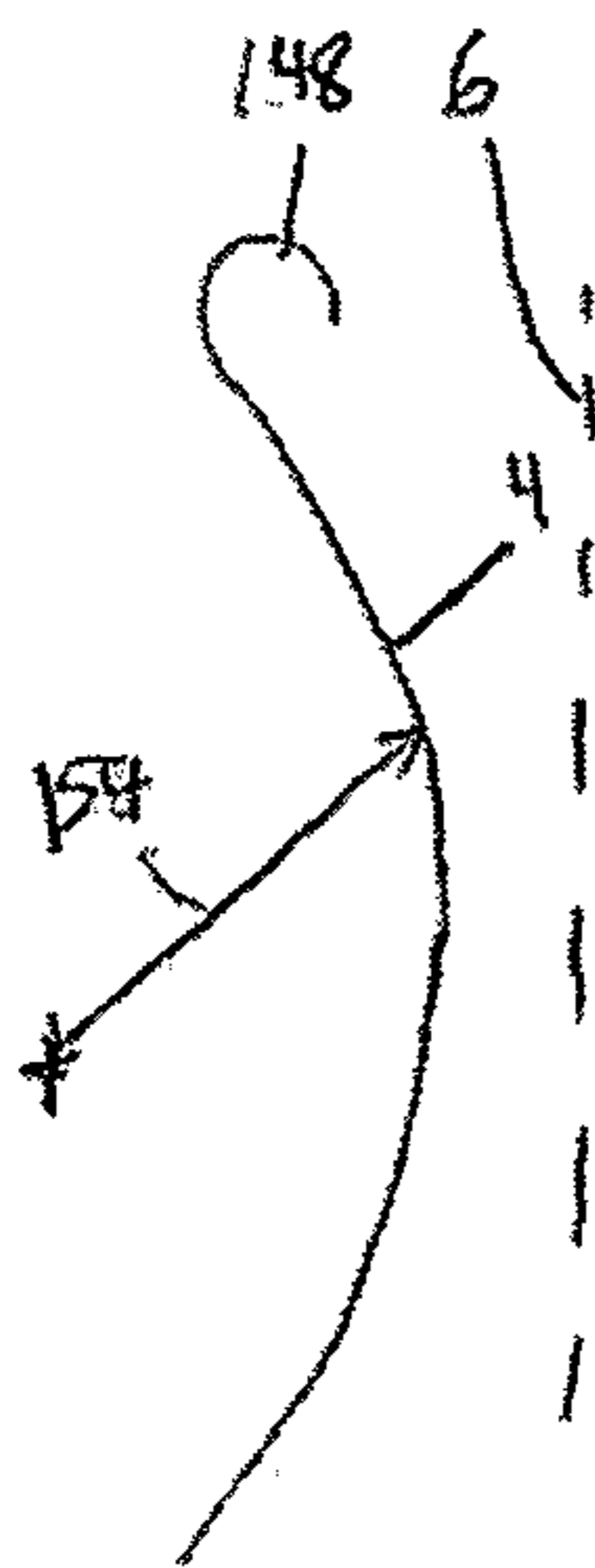

FIG. 39

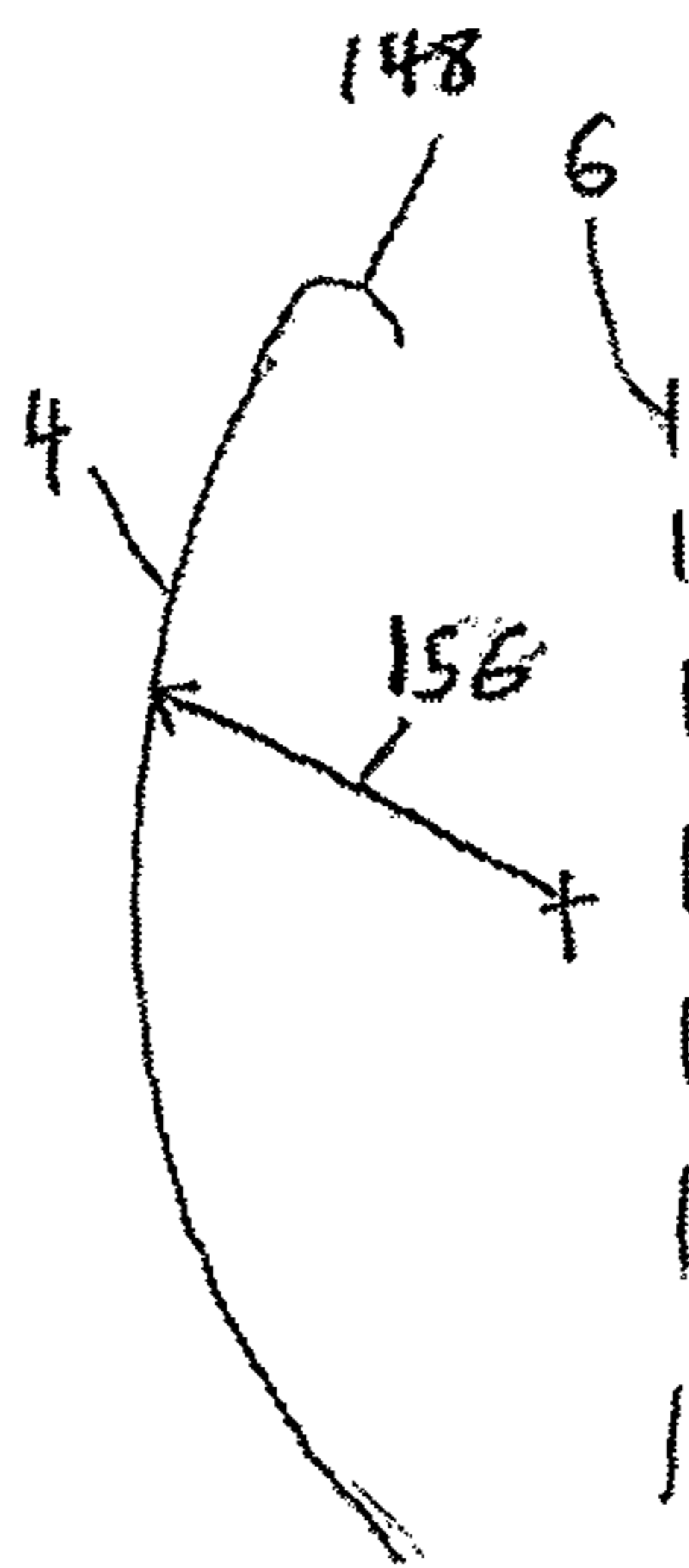

FIG. 40

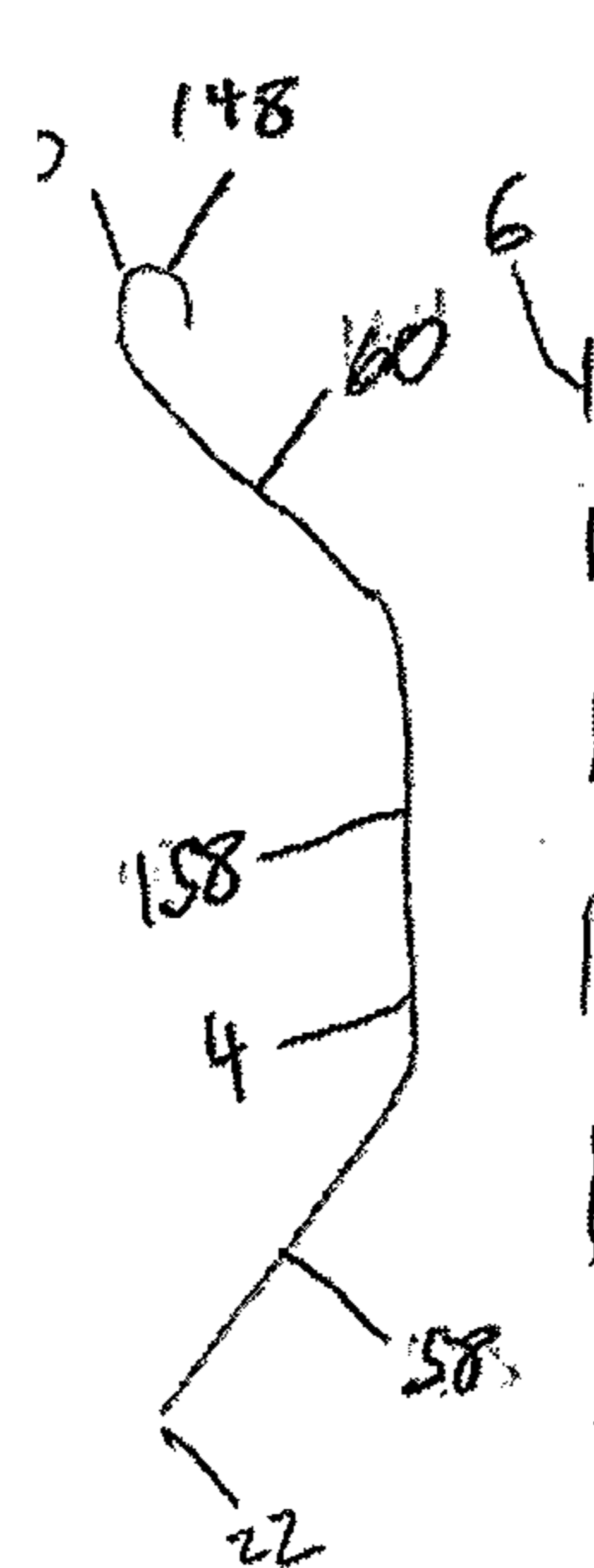

FIG. 41

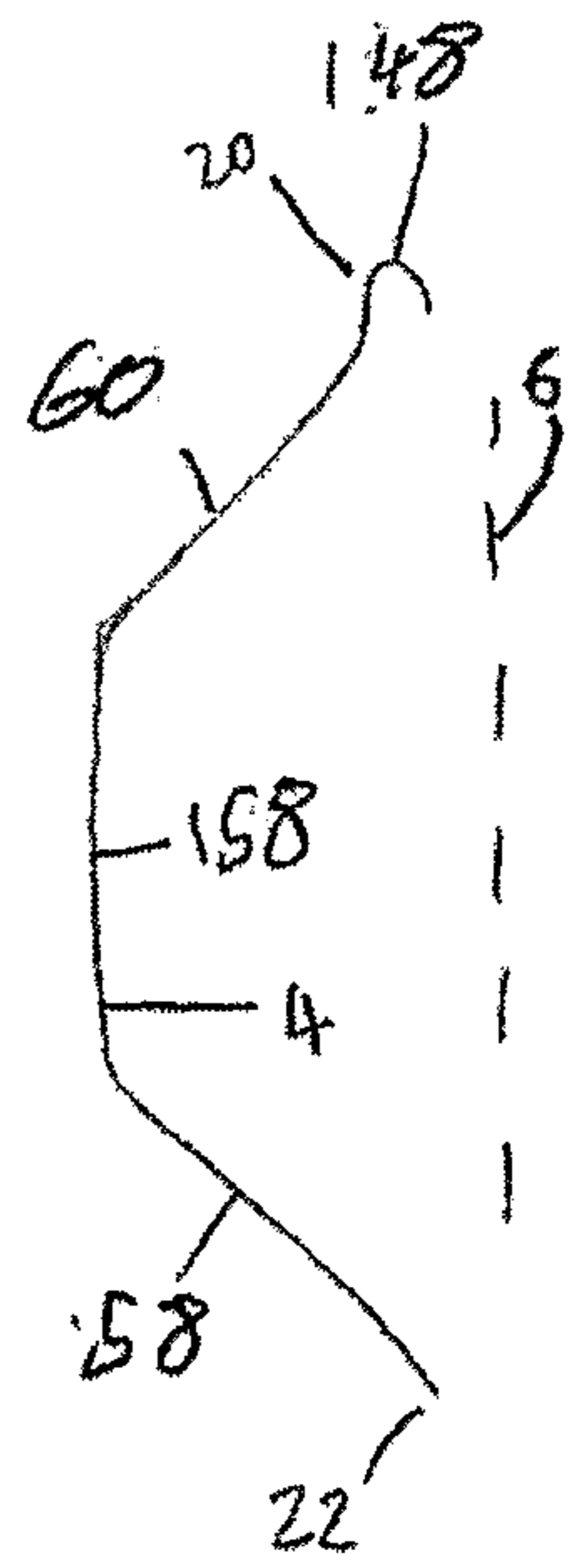

FIG. 42

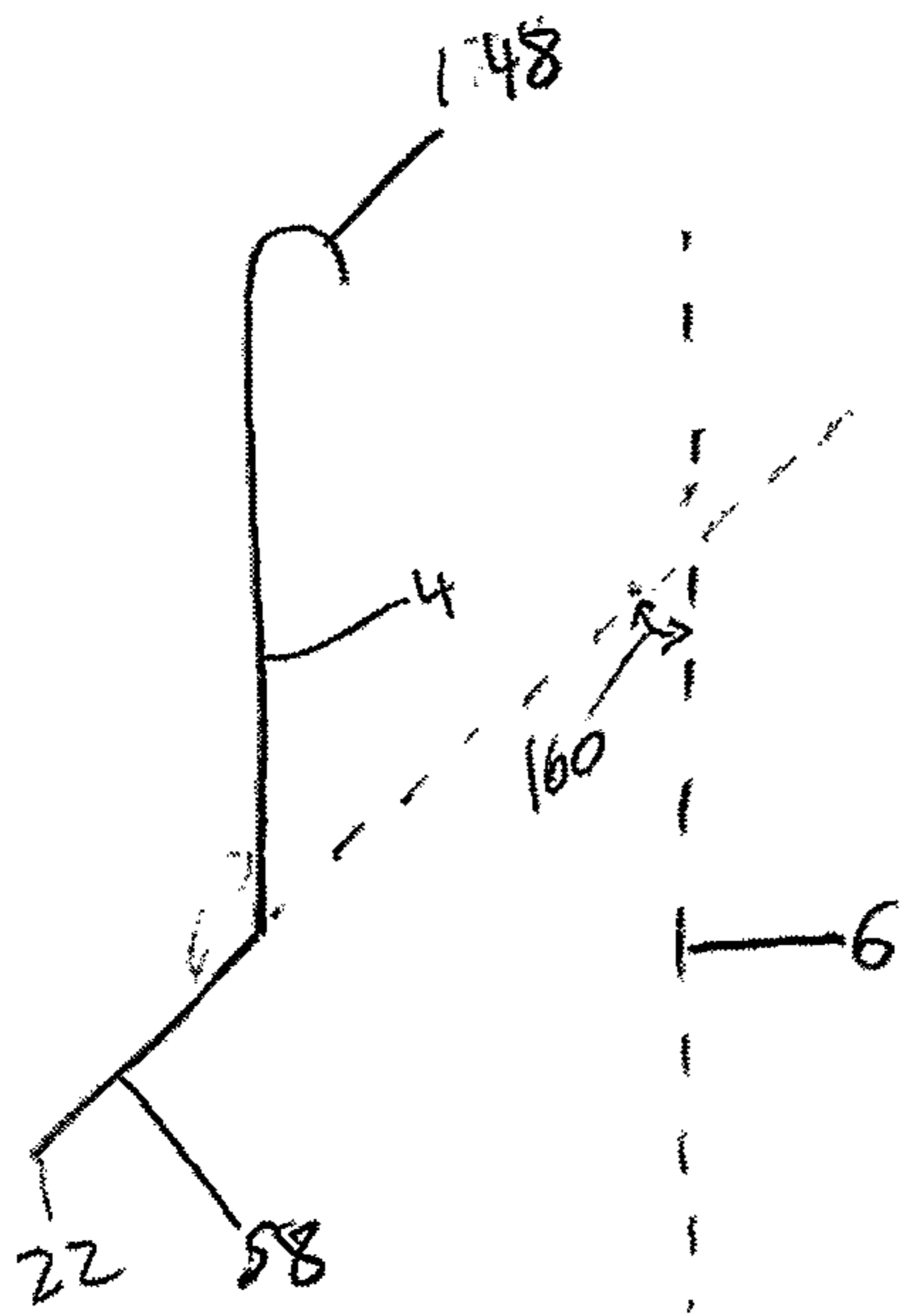

FIG. 43

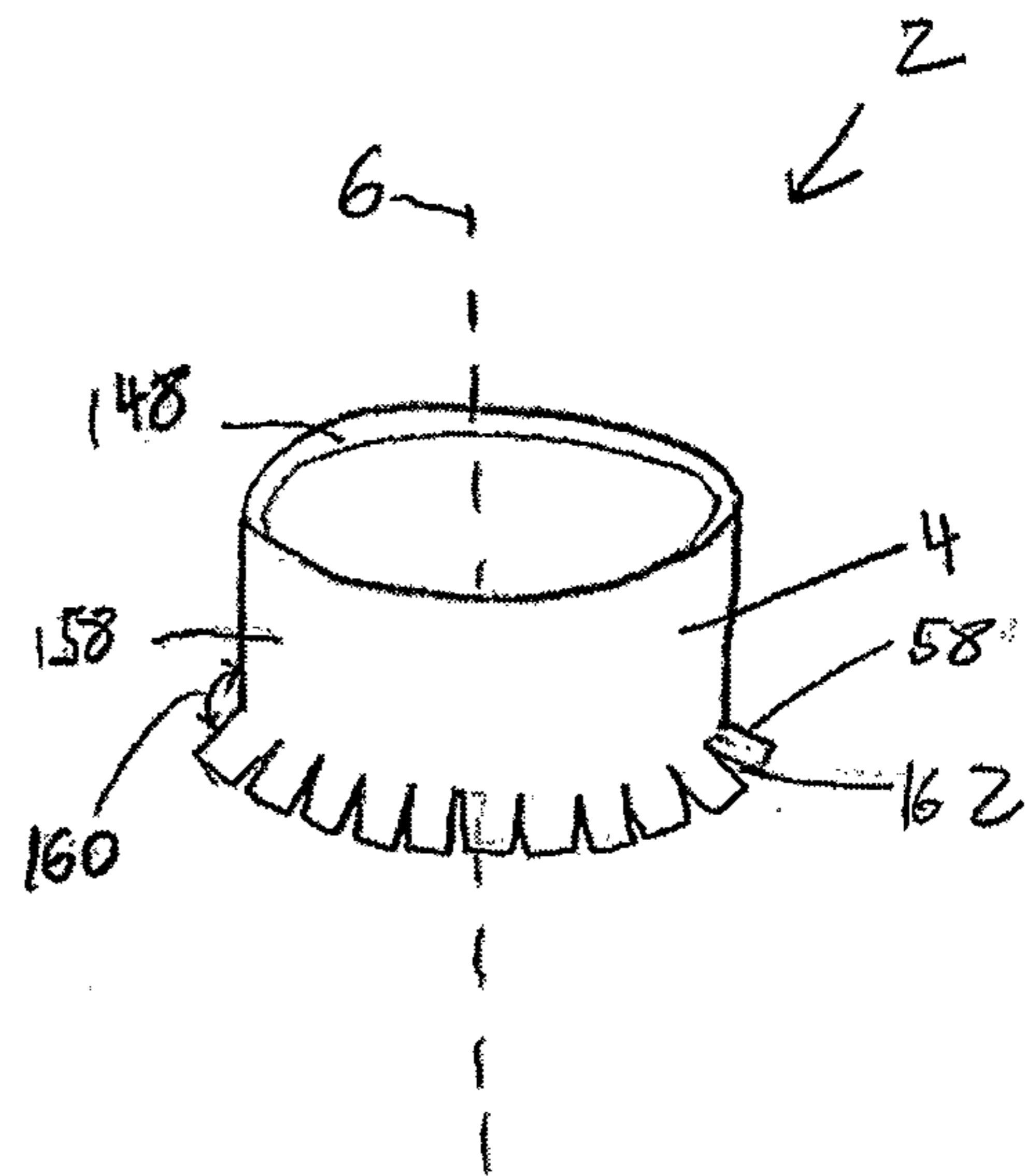

FIG. 44

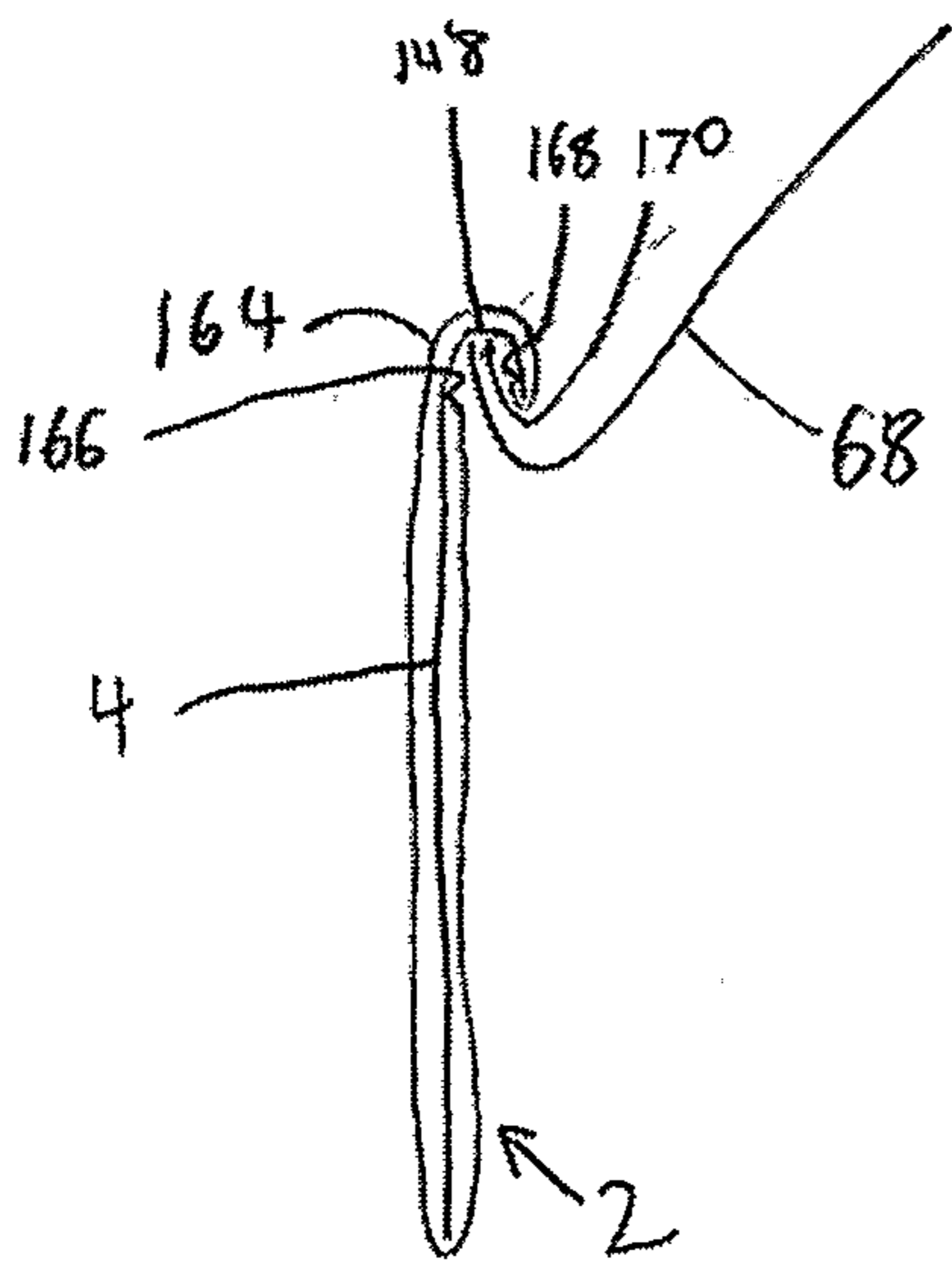

FIG. 45

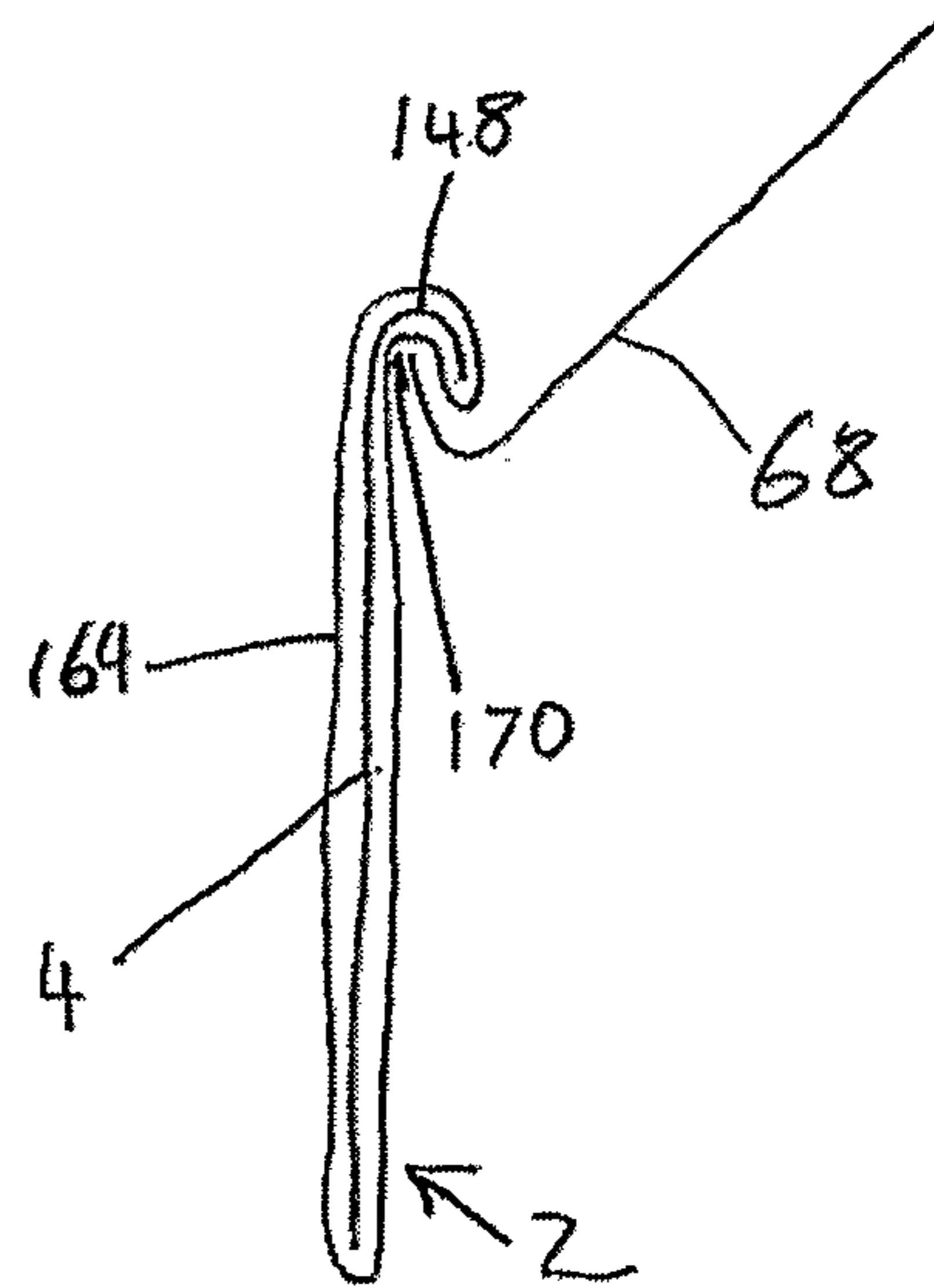

FIG. 46



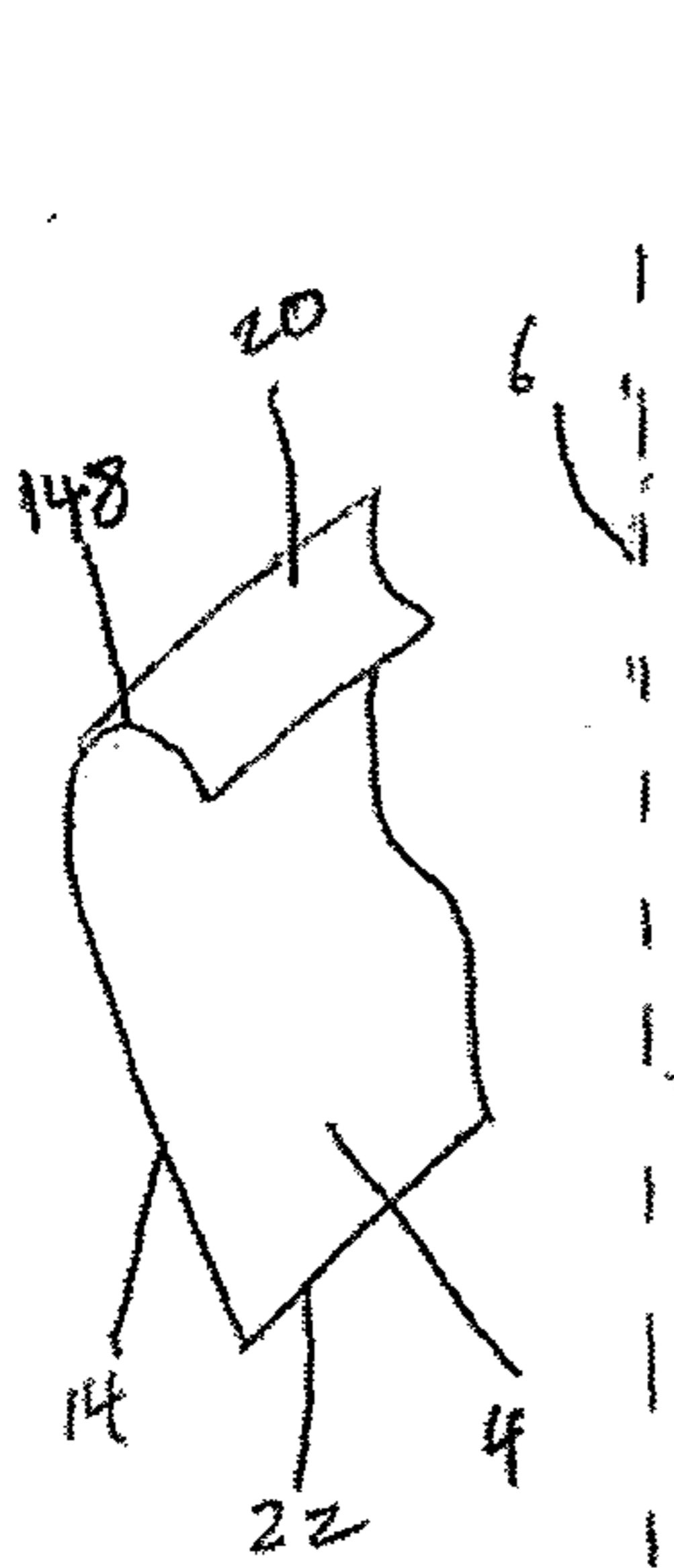

FIG. 47

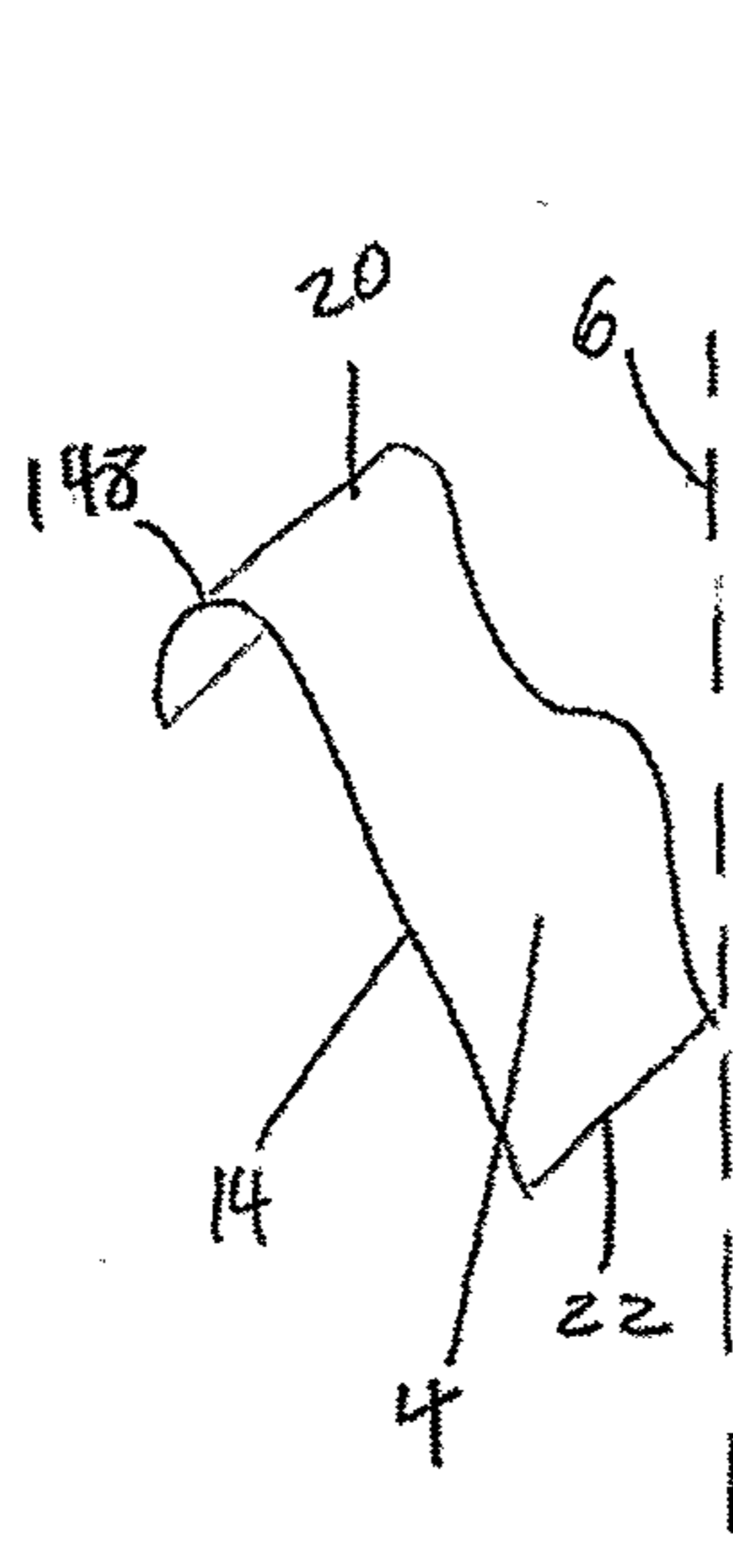

FIG. 48

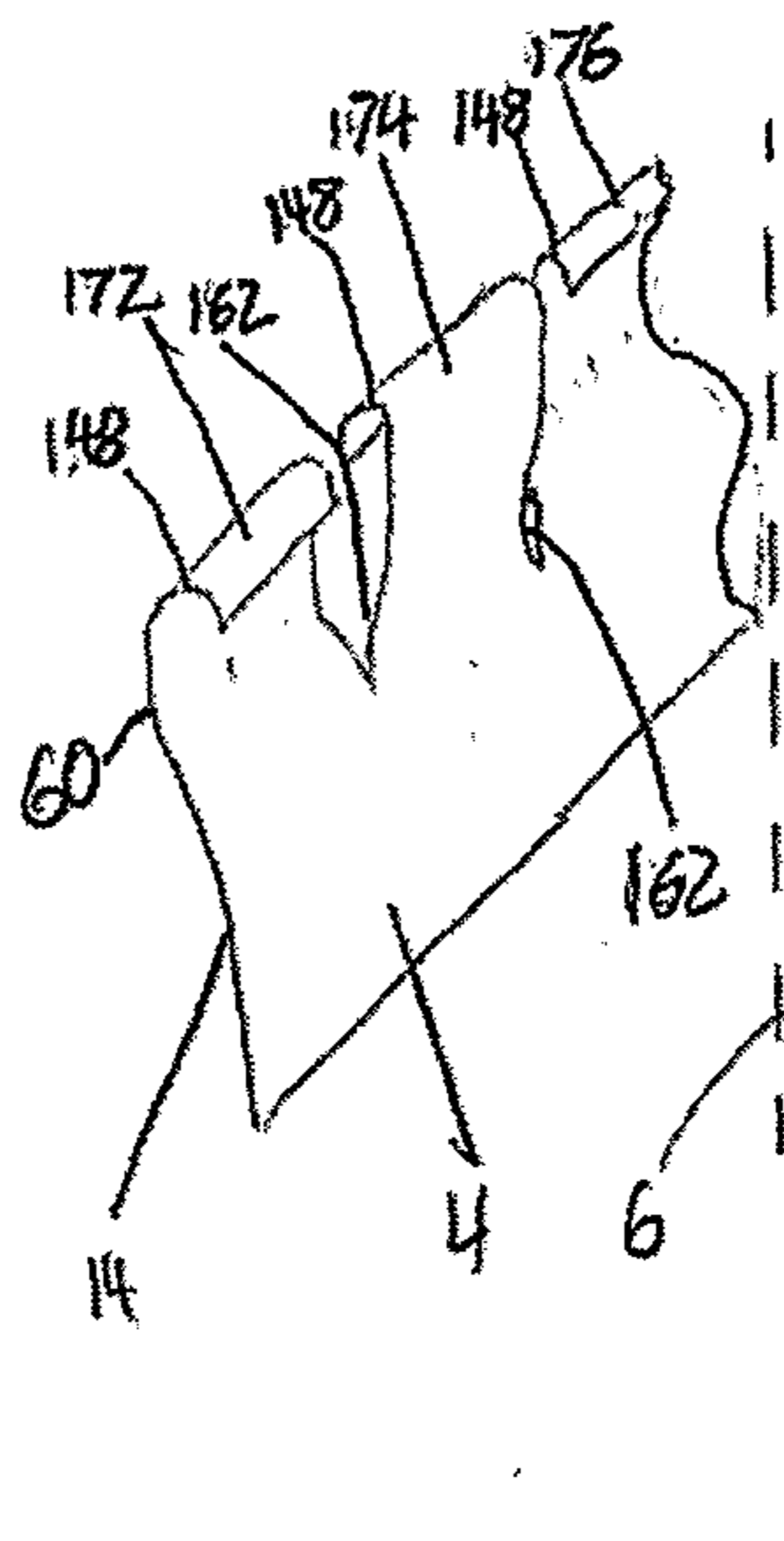

FIG. 49

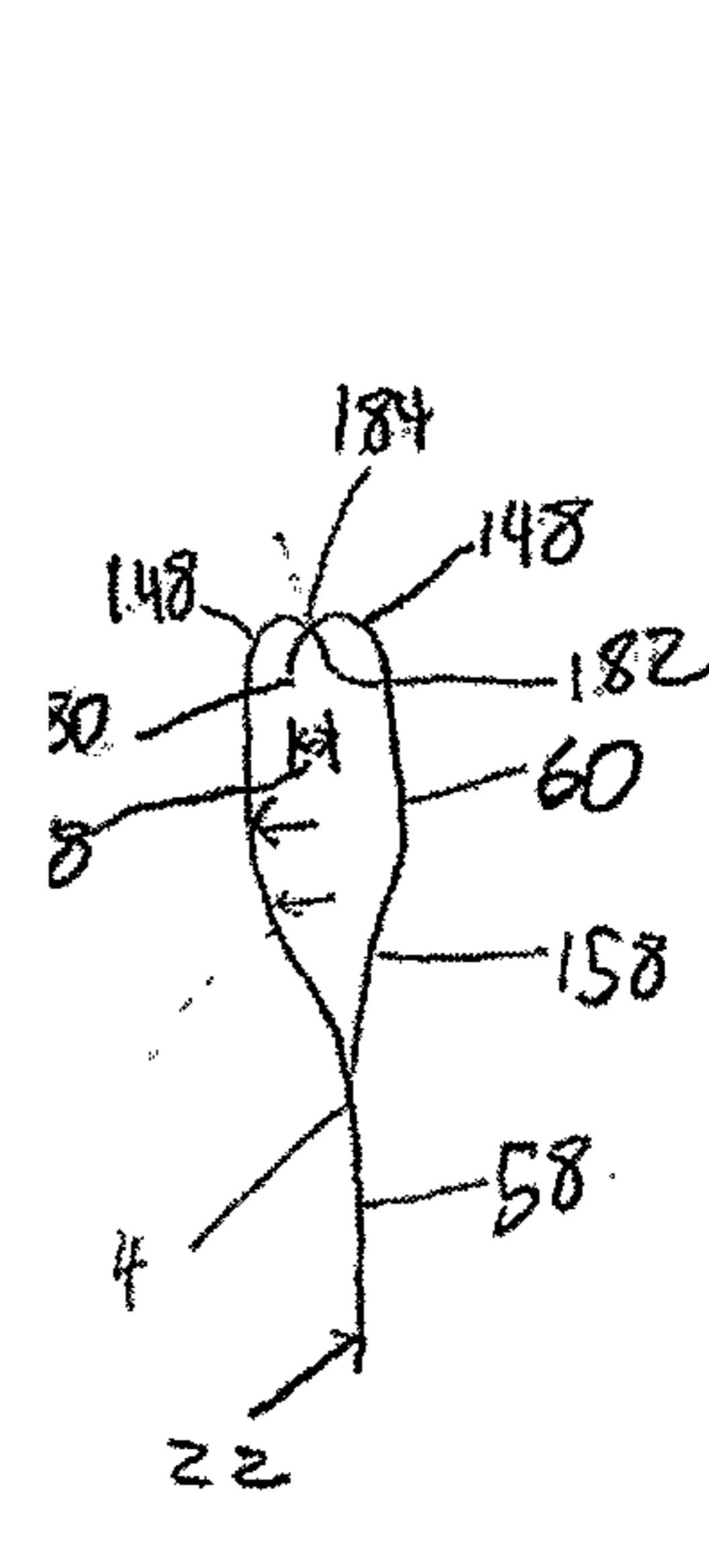

FIG. 50

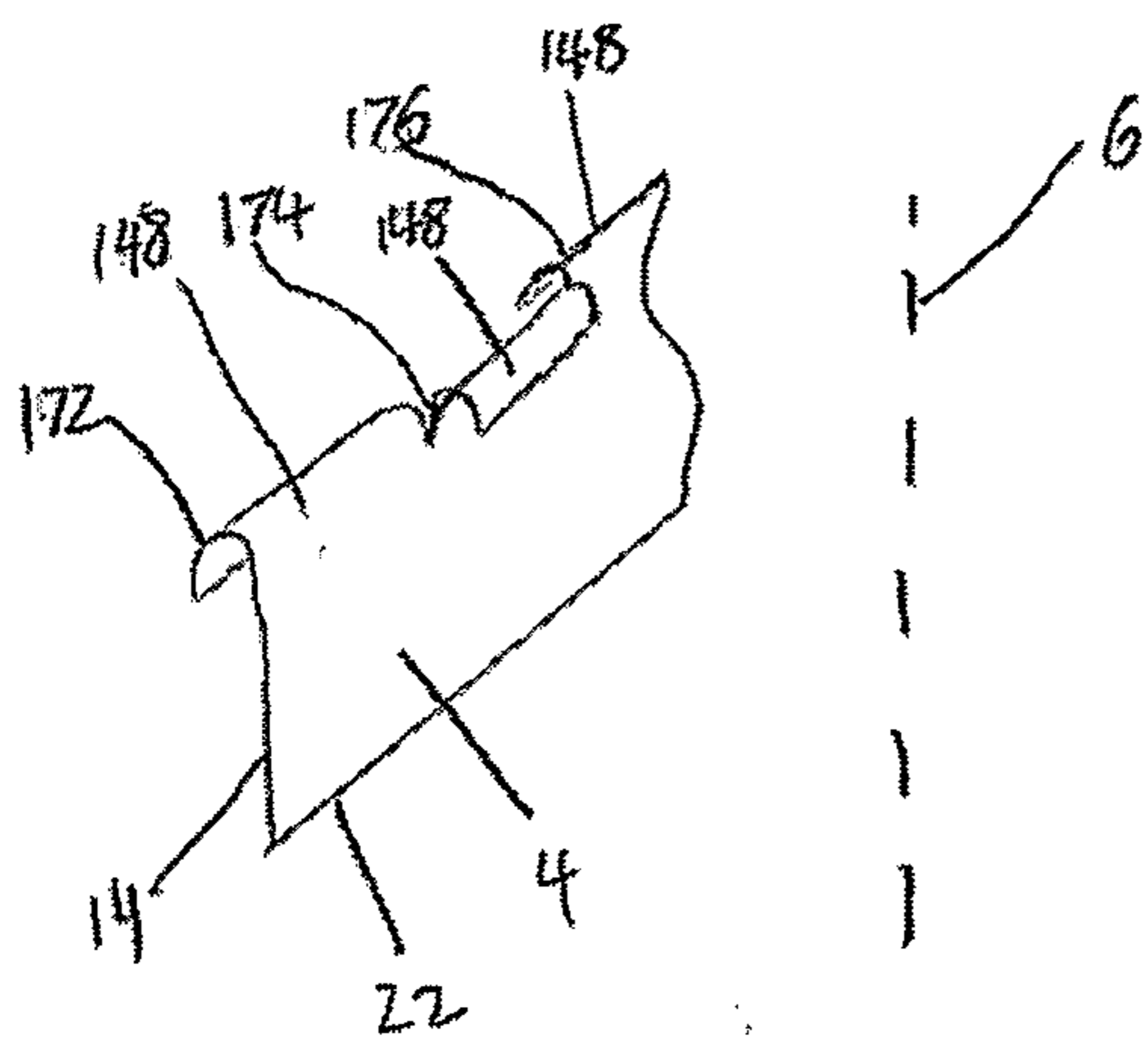

FIG. 51

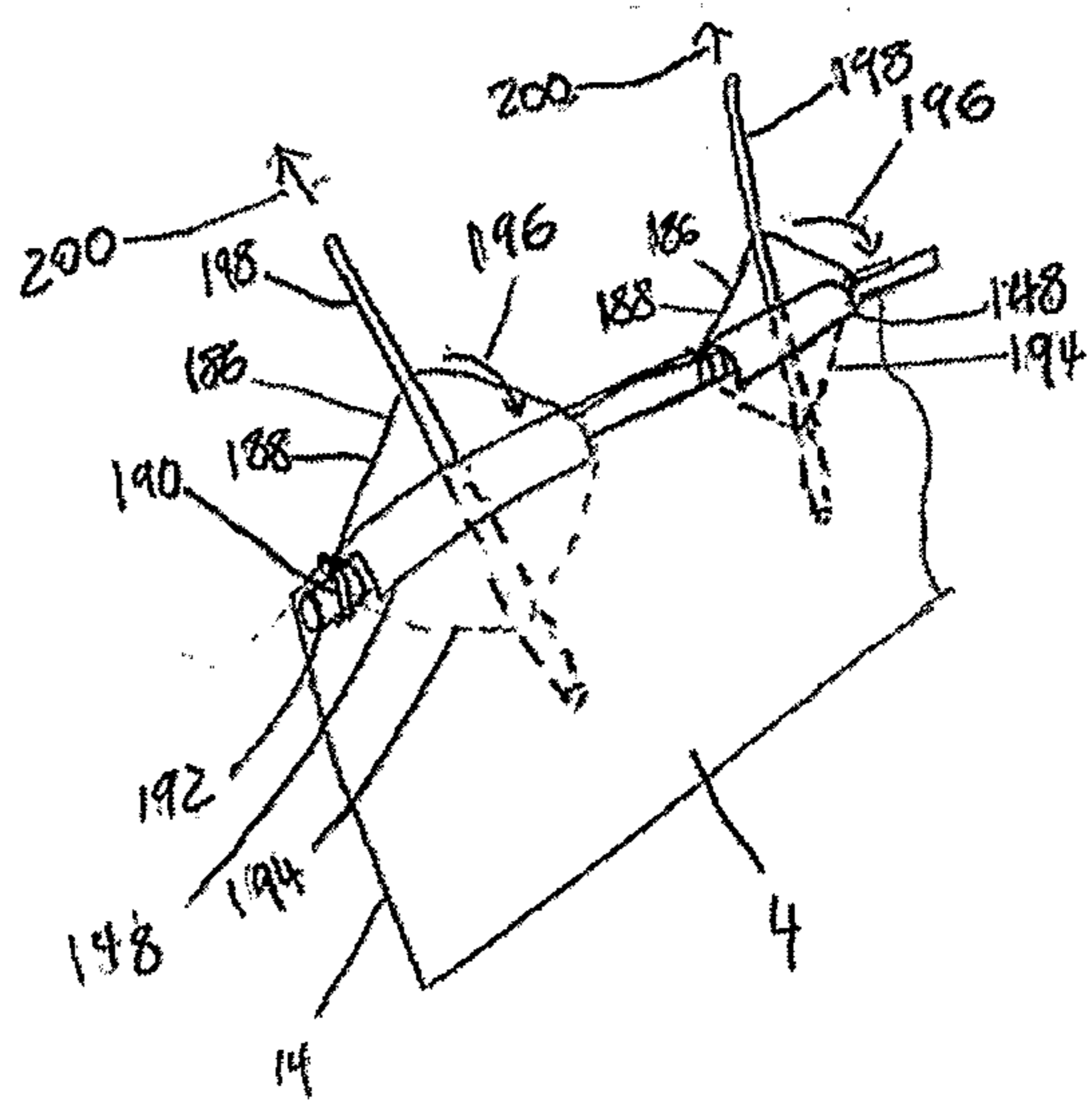

FIG. 52

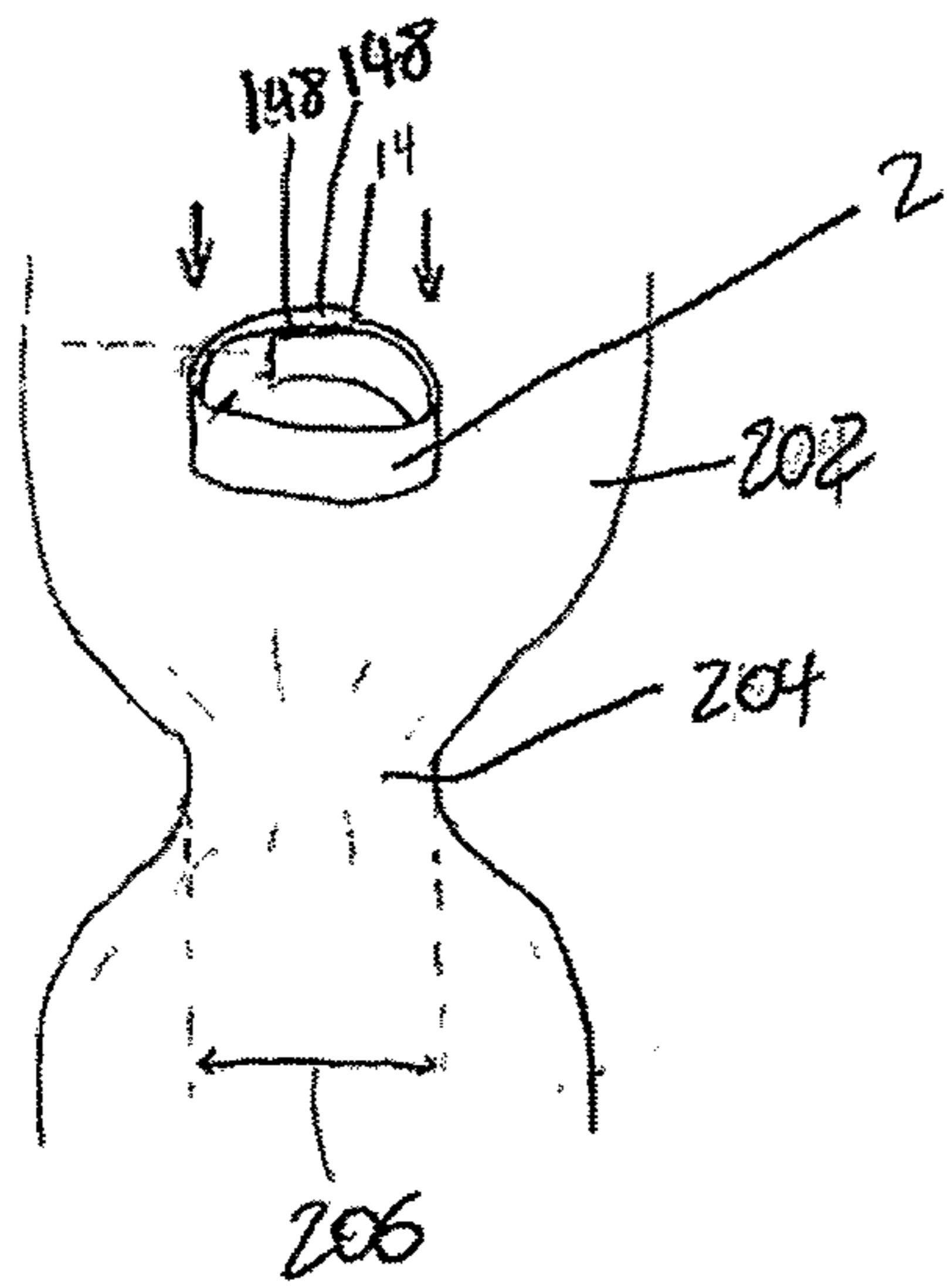

FIG. 53

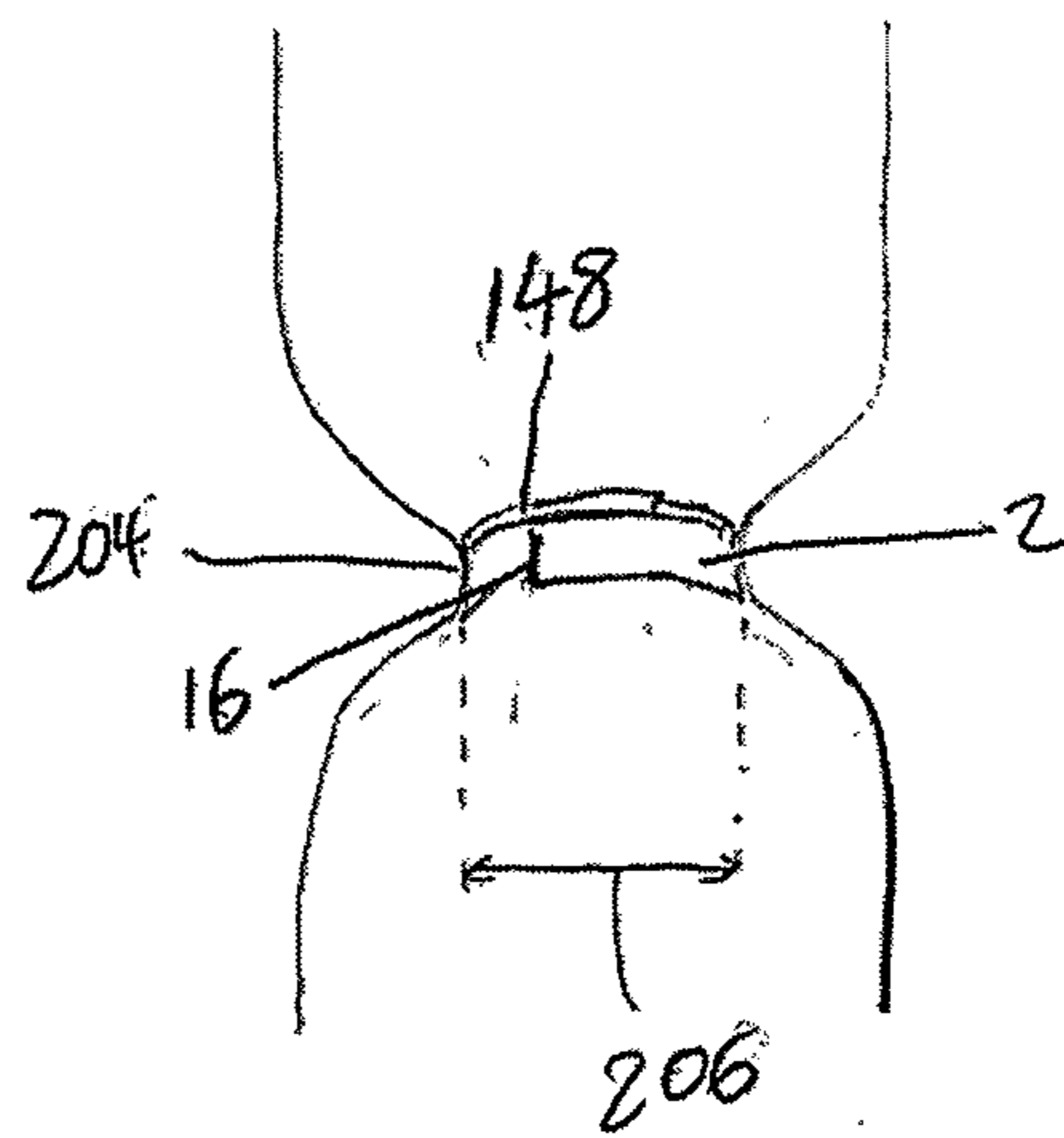

FIG. 54

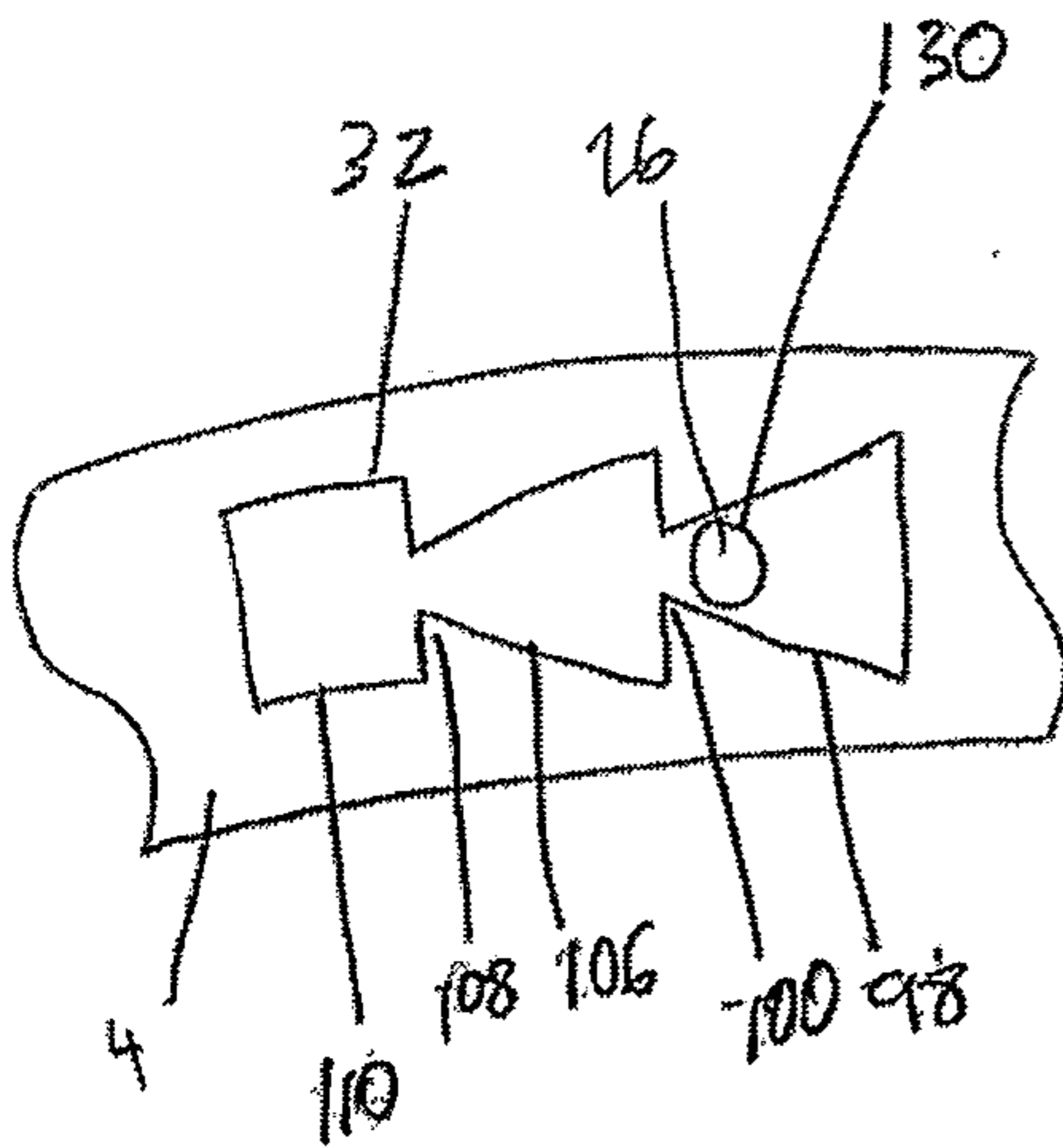

FIG. 55

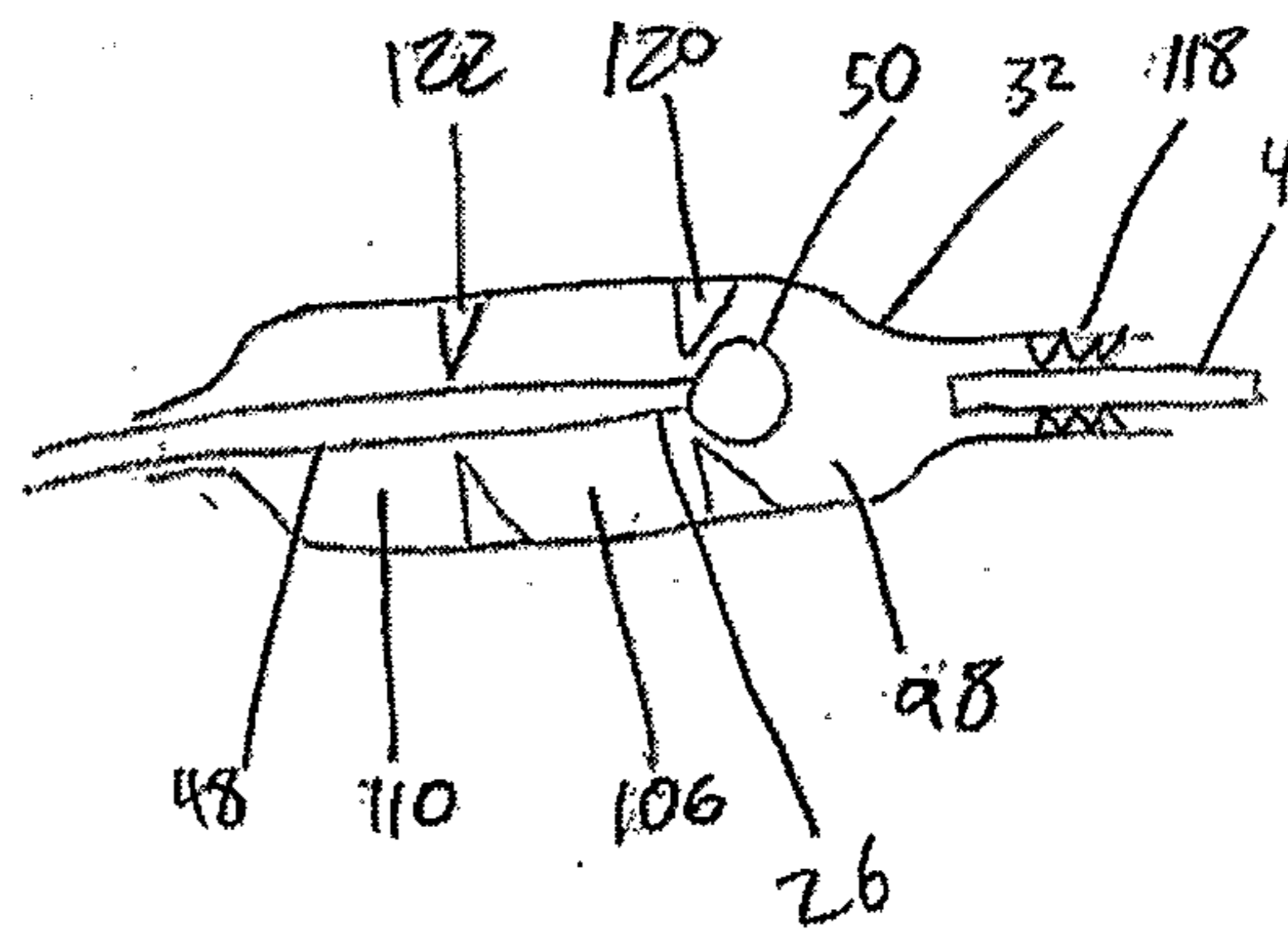

FIG. 56

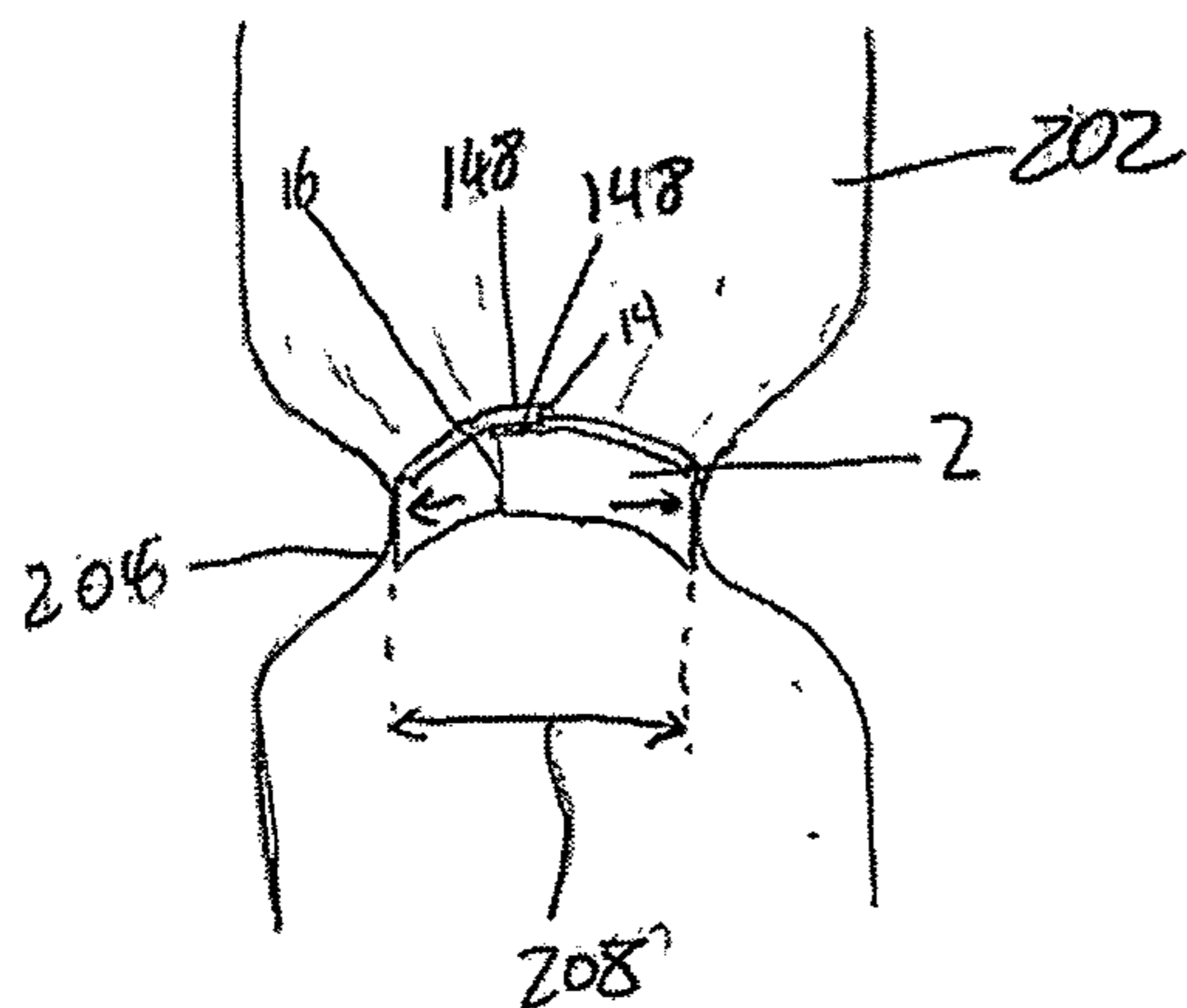

FIG. 57

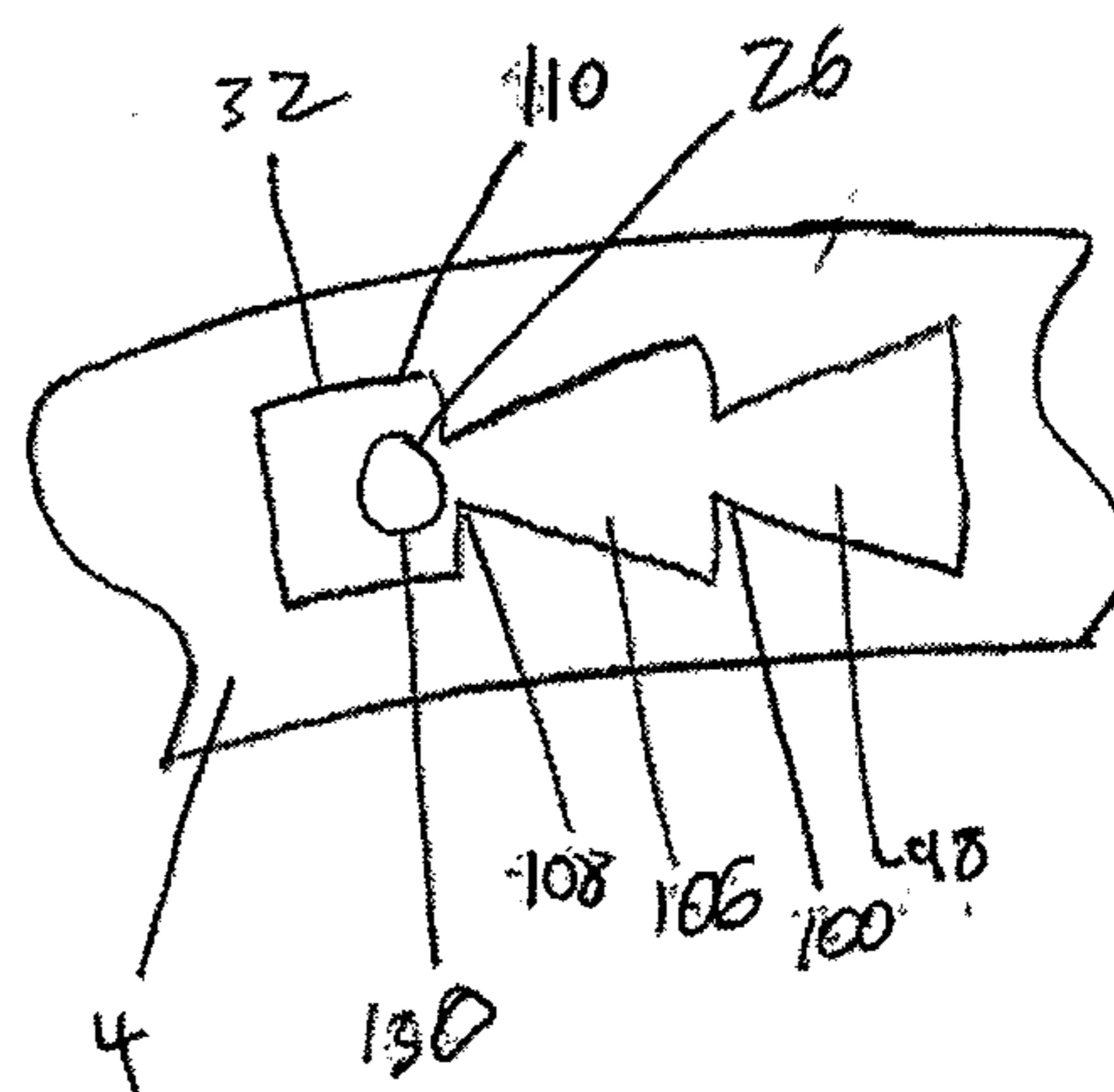

FIG. 62

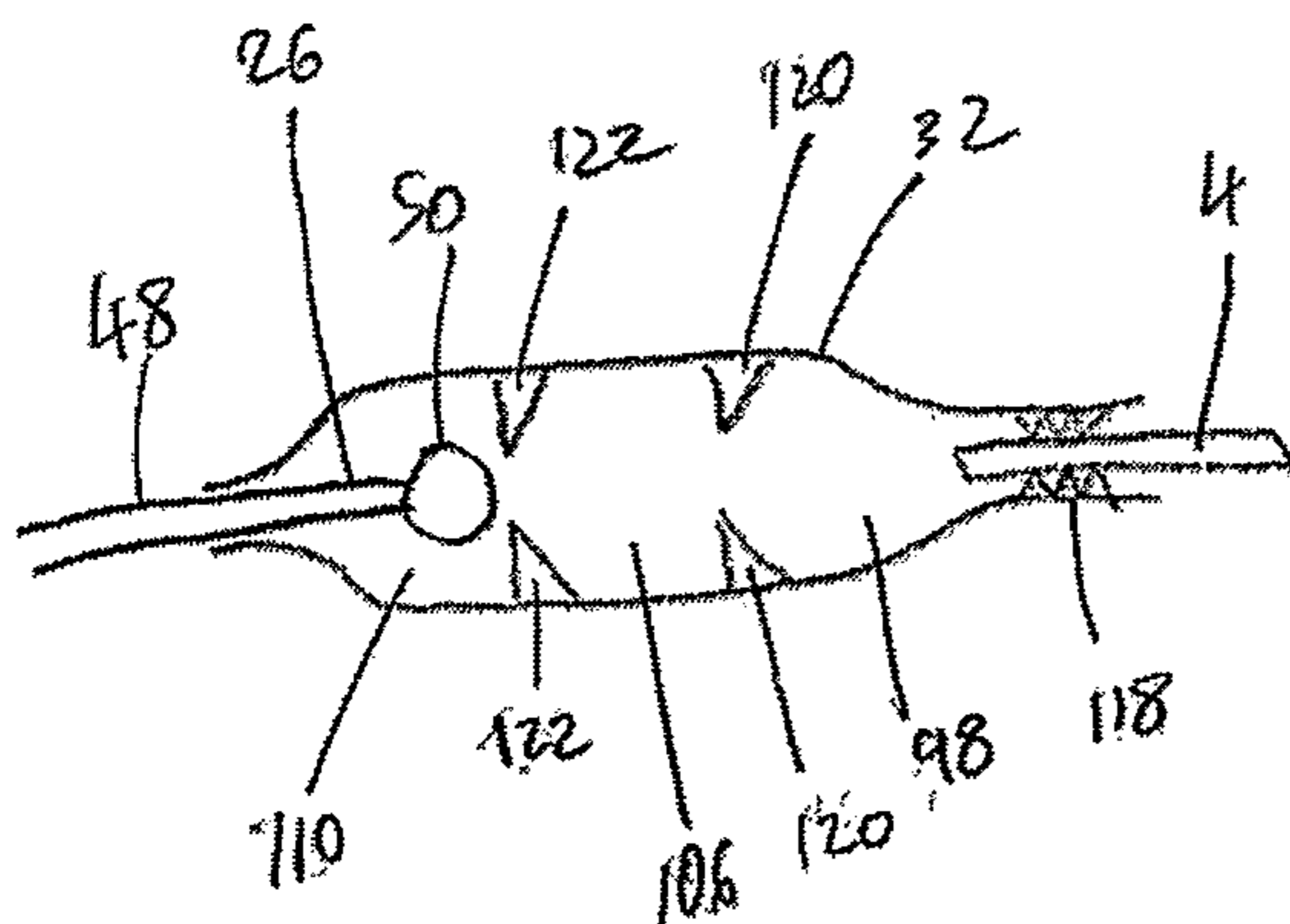

FIG. 63

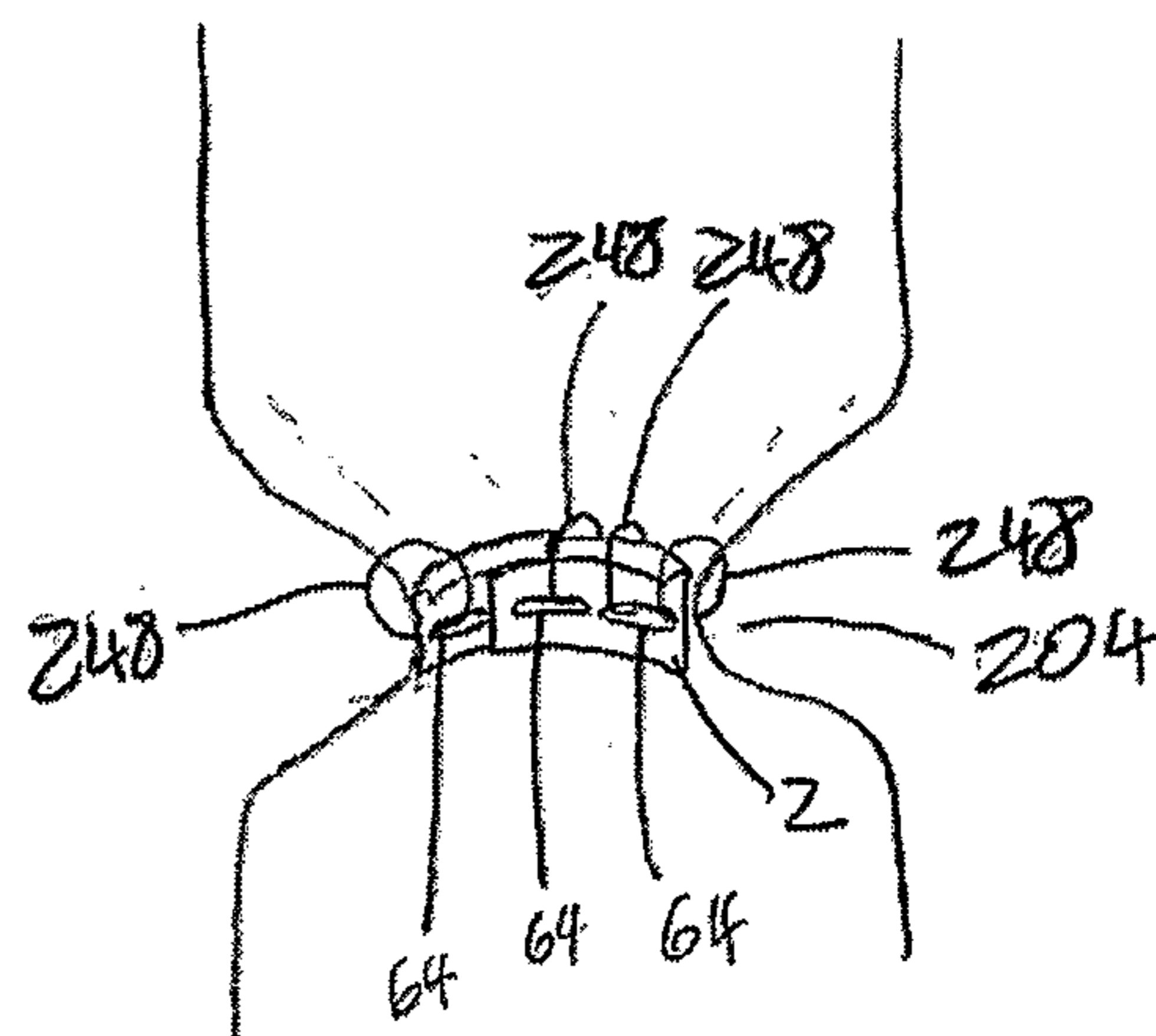

FIG. 64

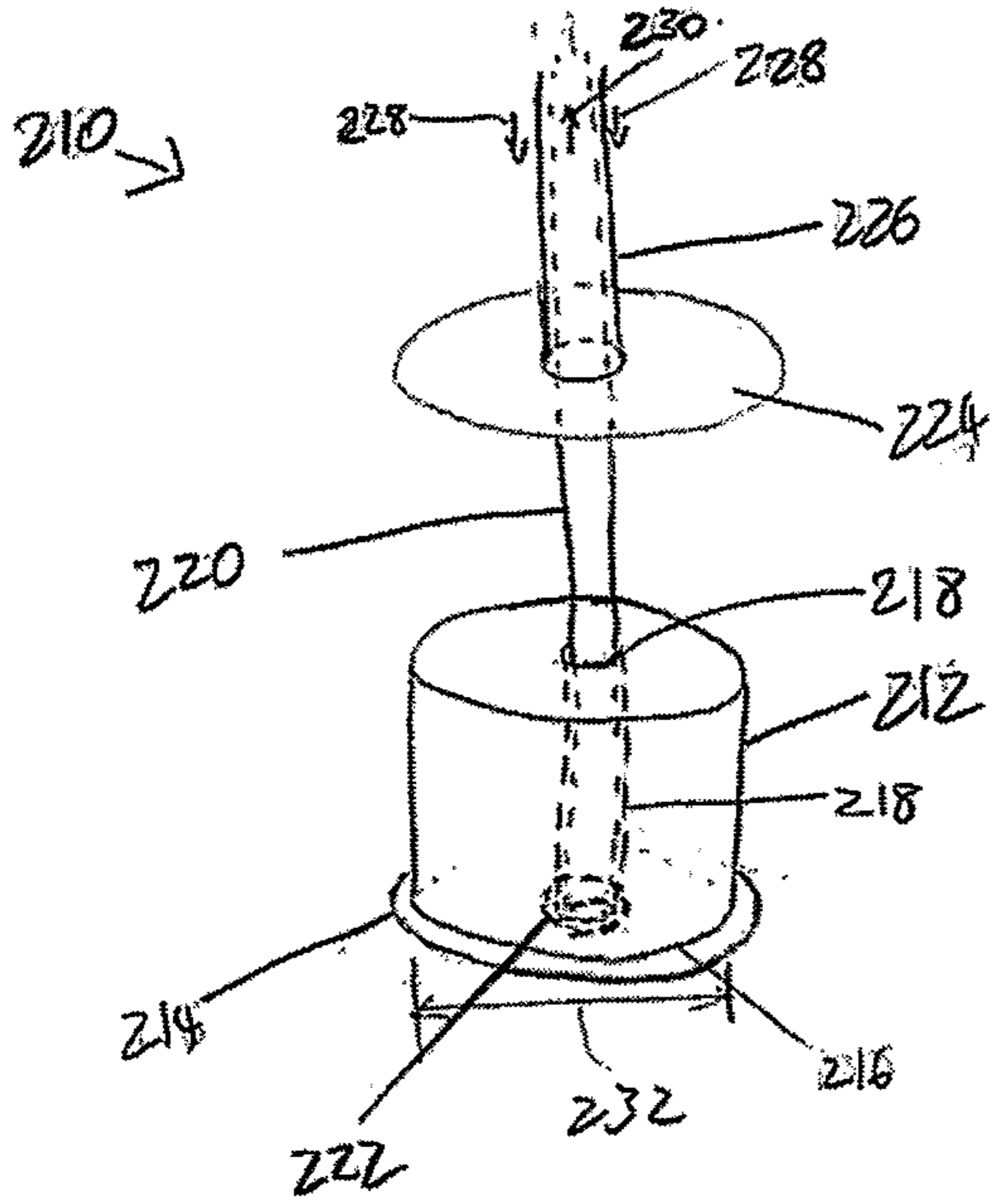

FIG. 58

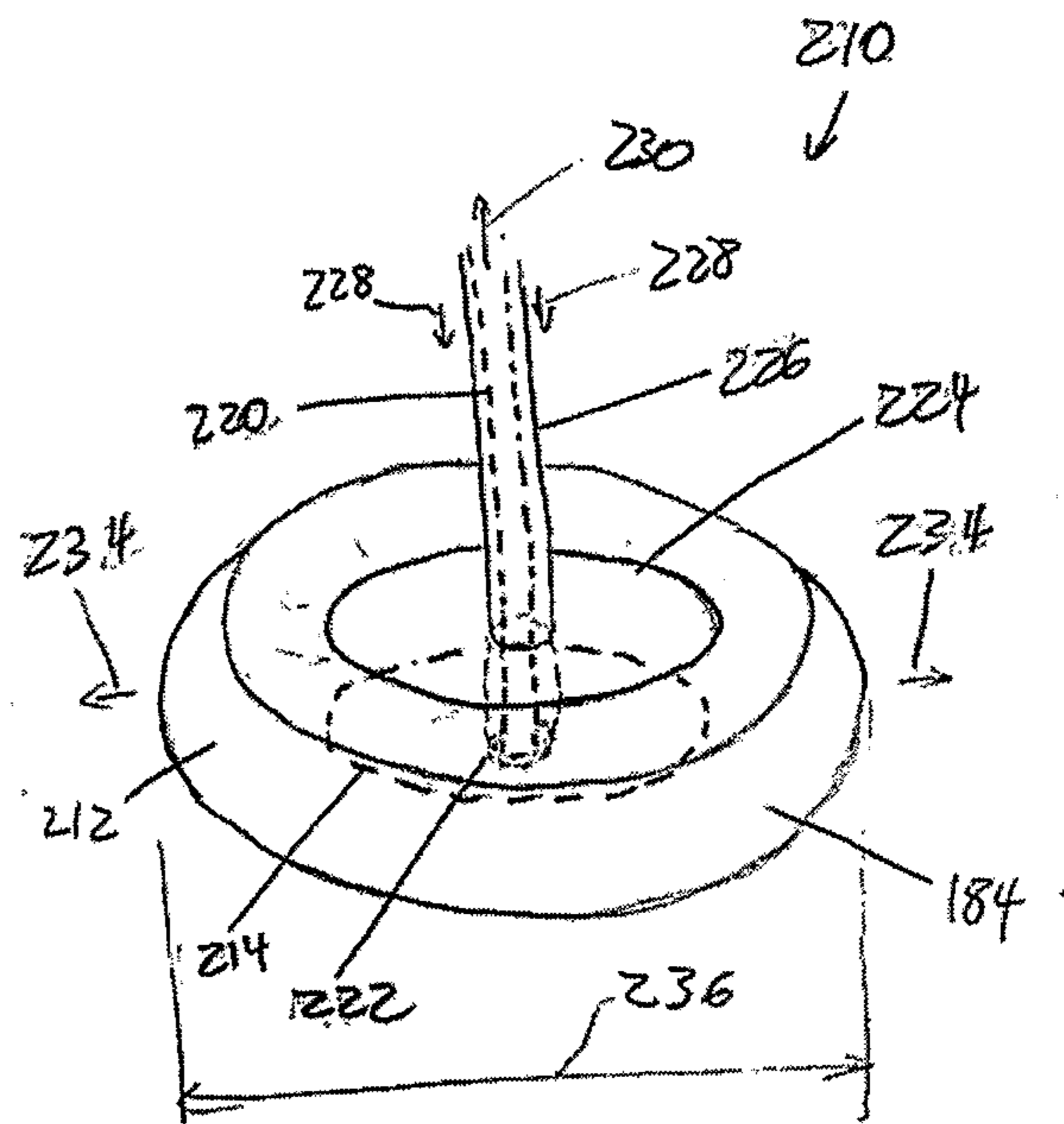

FIG. 59

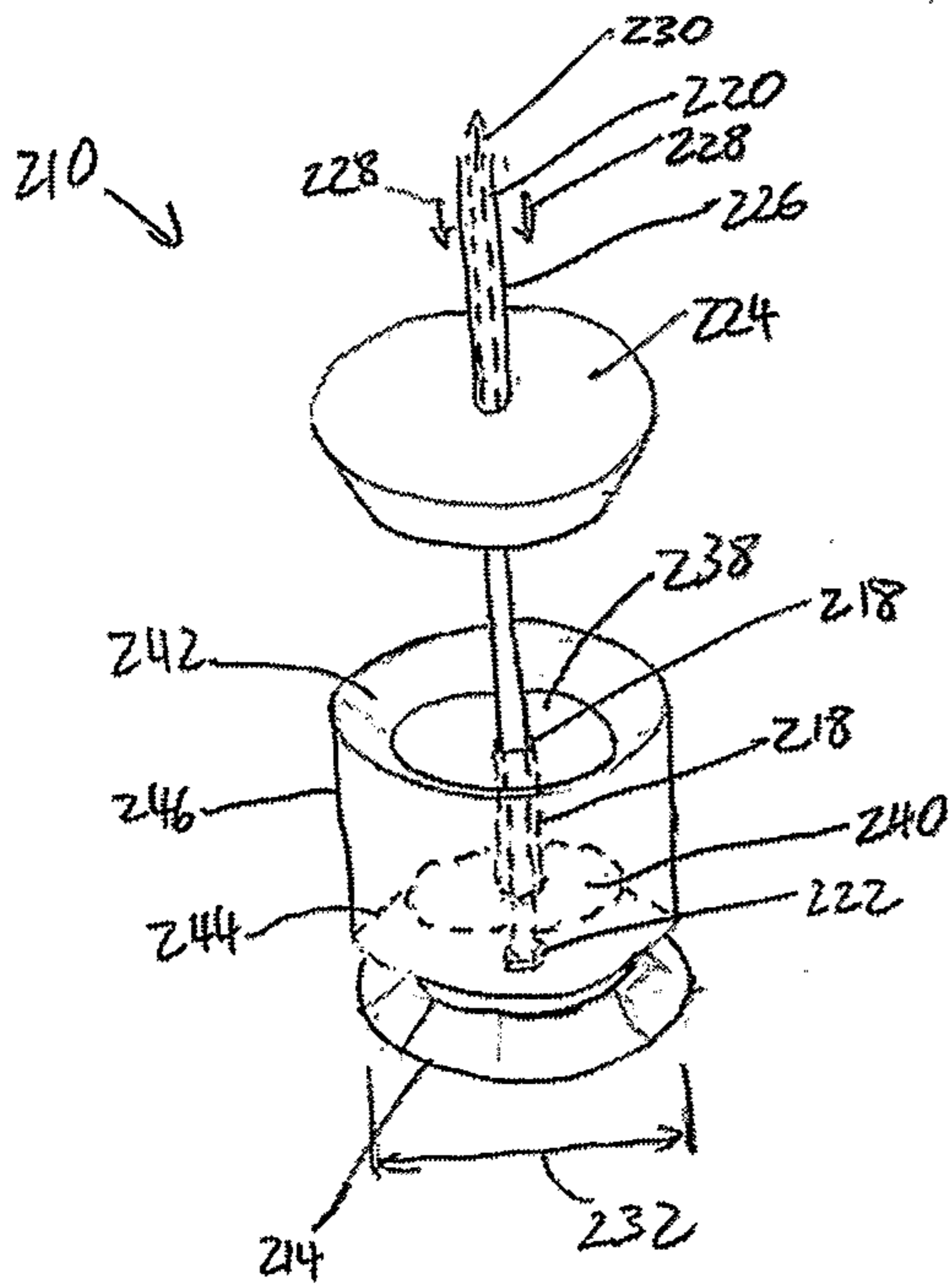

FIG. 60

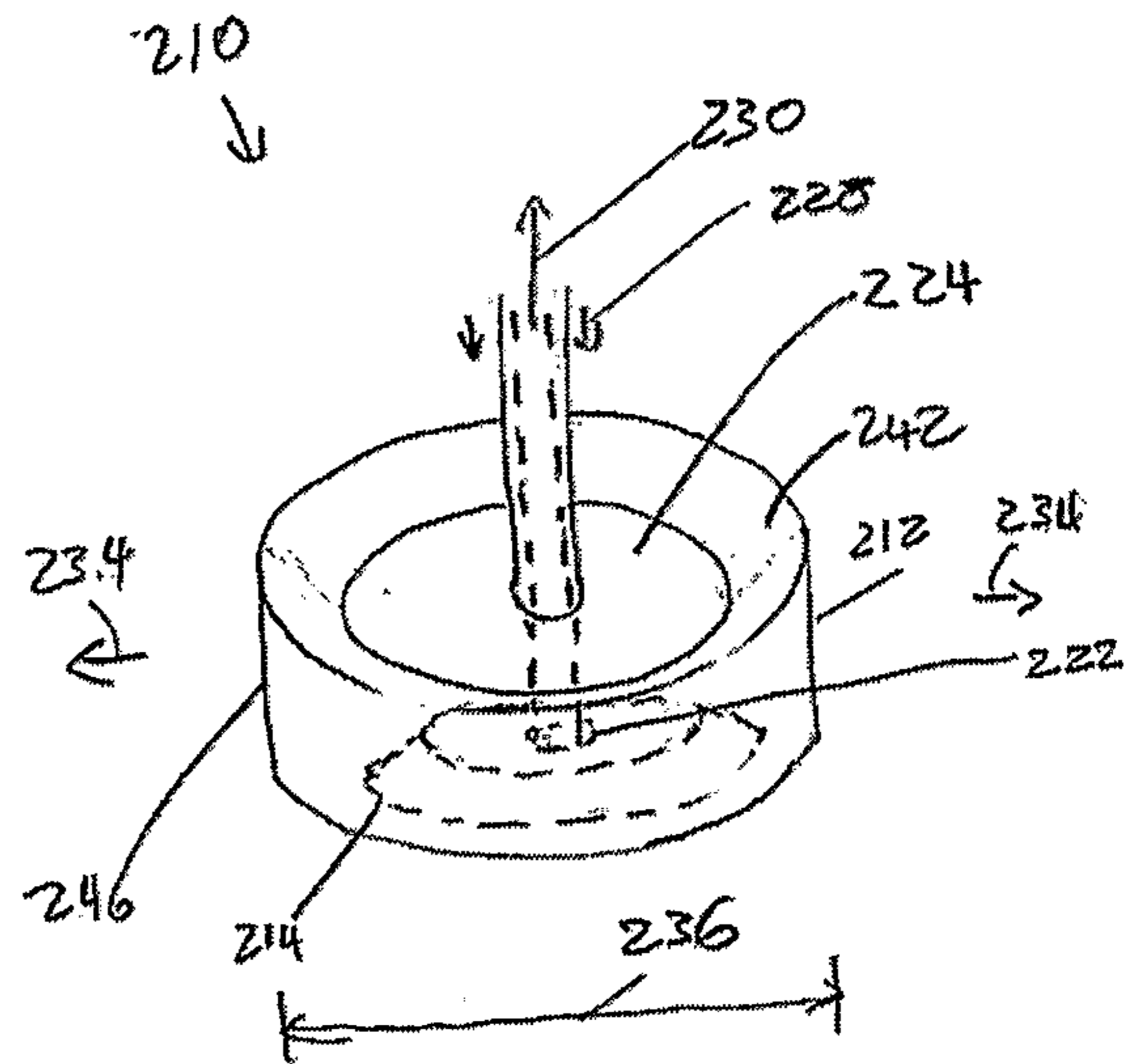

FIG. 61

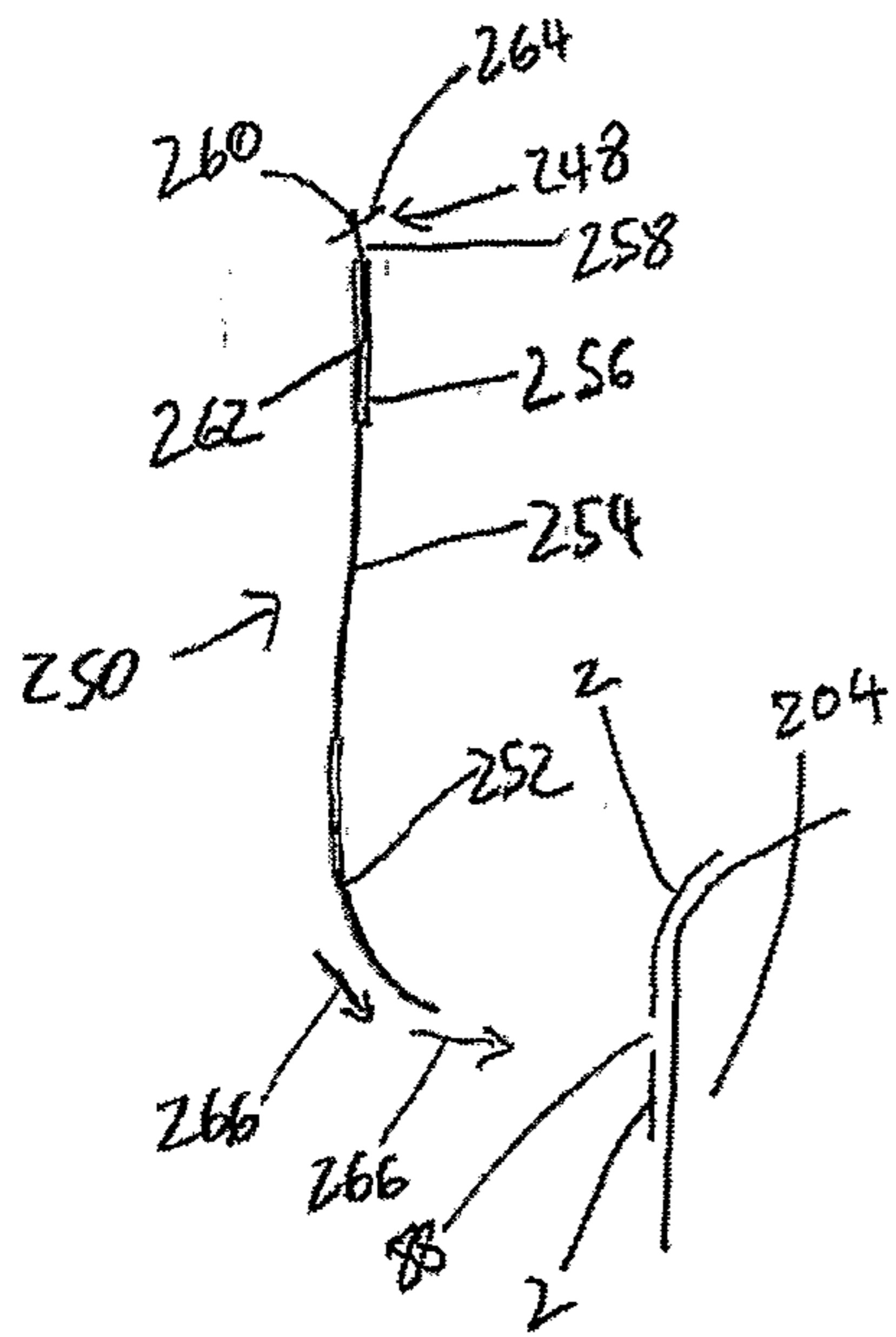

FIG. 65

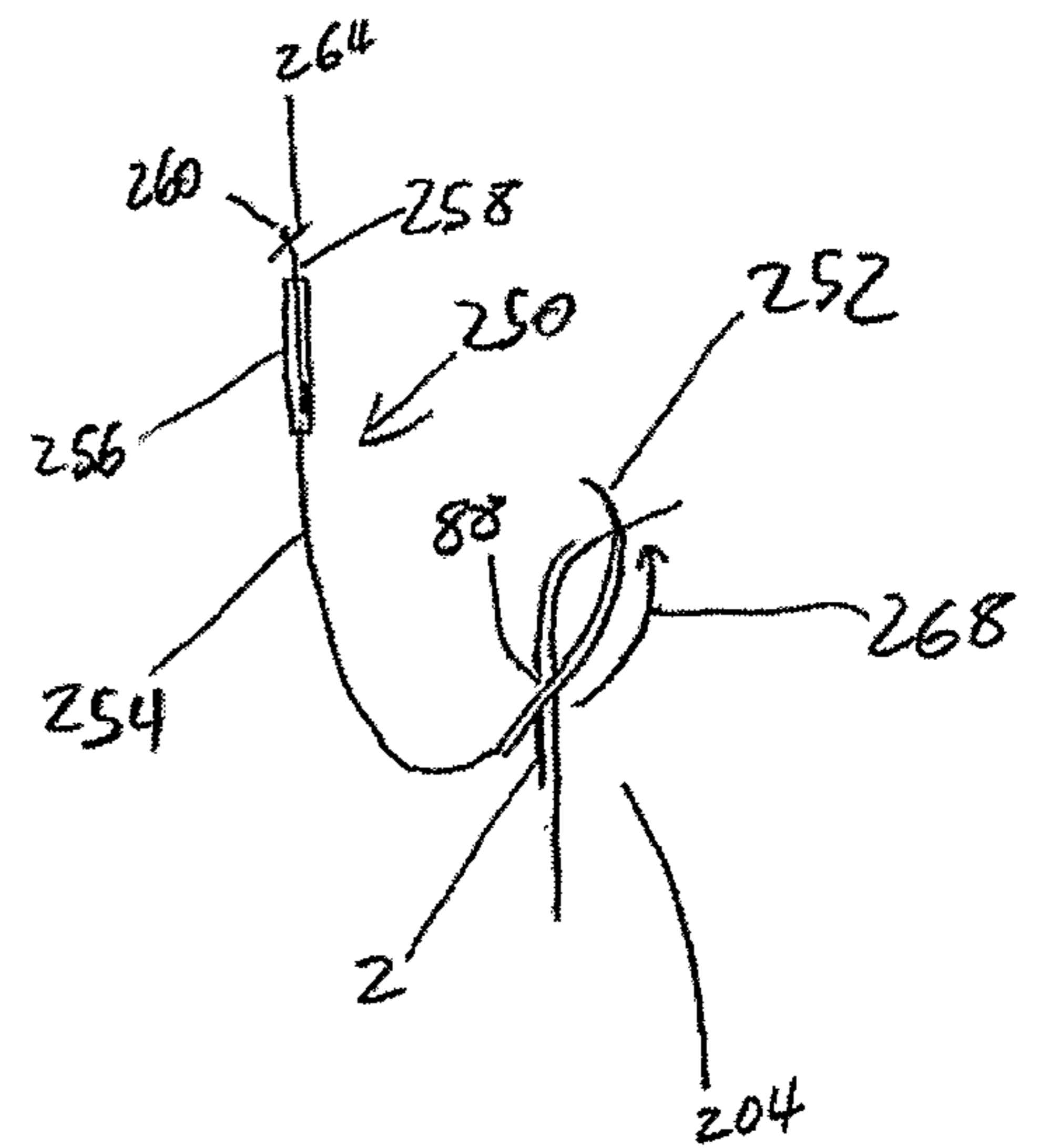

FIG. 66

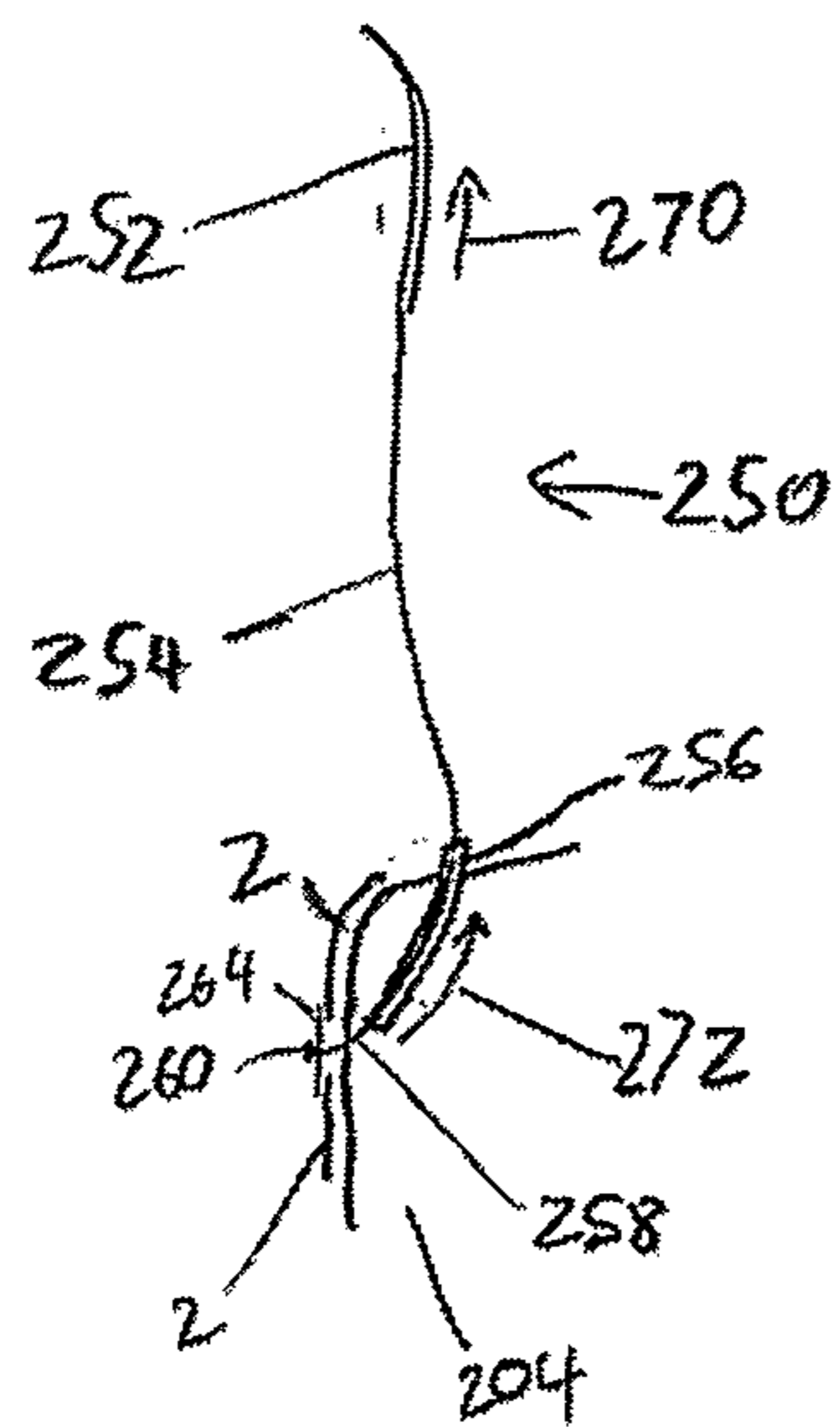

FIG. 67

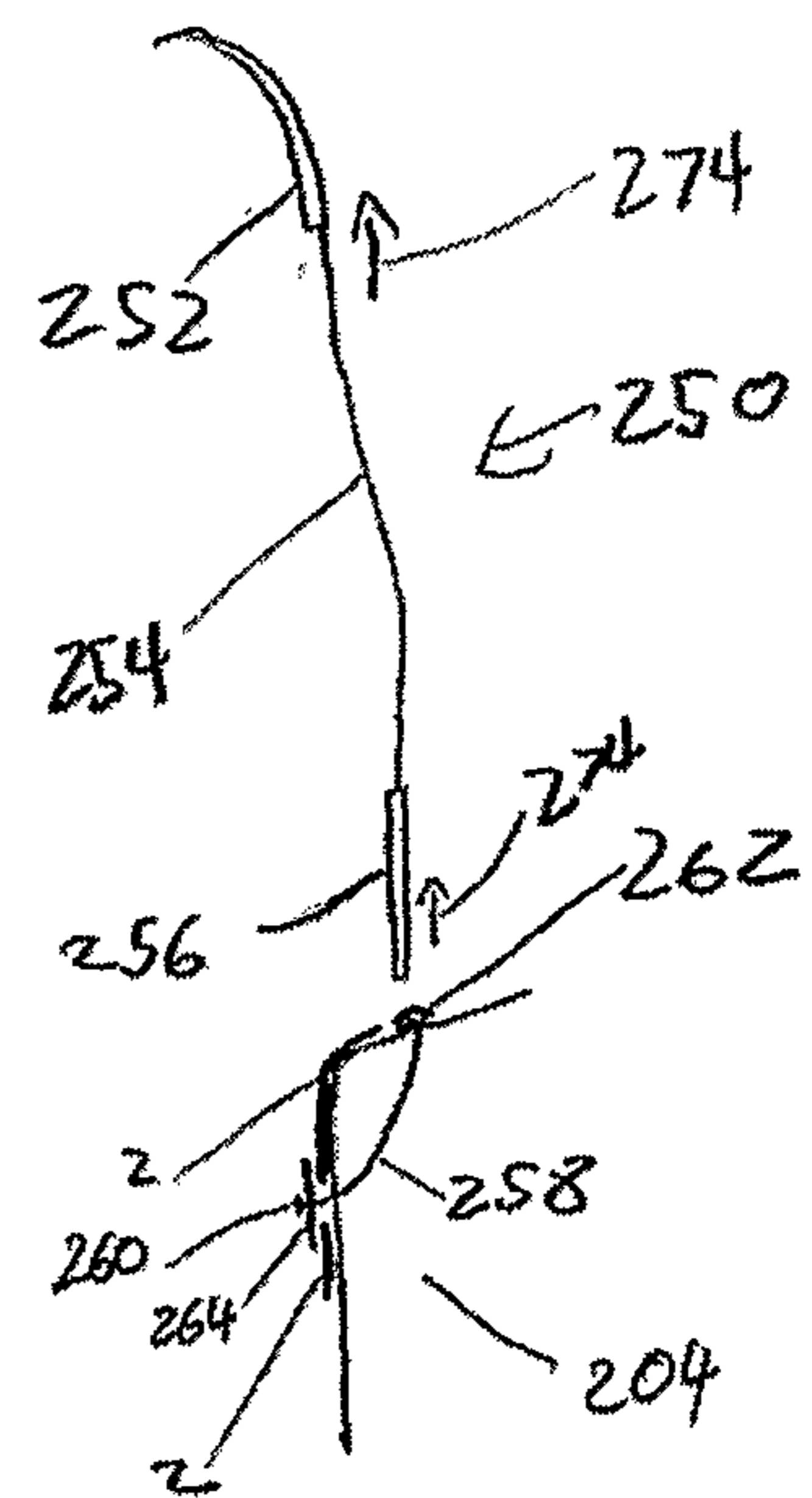

FIG. 68

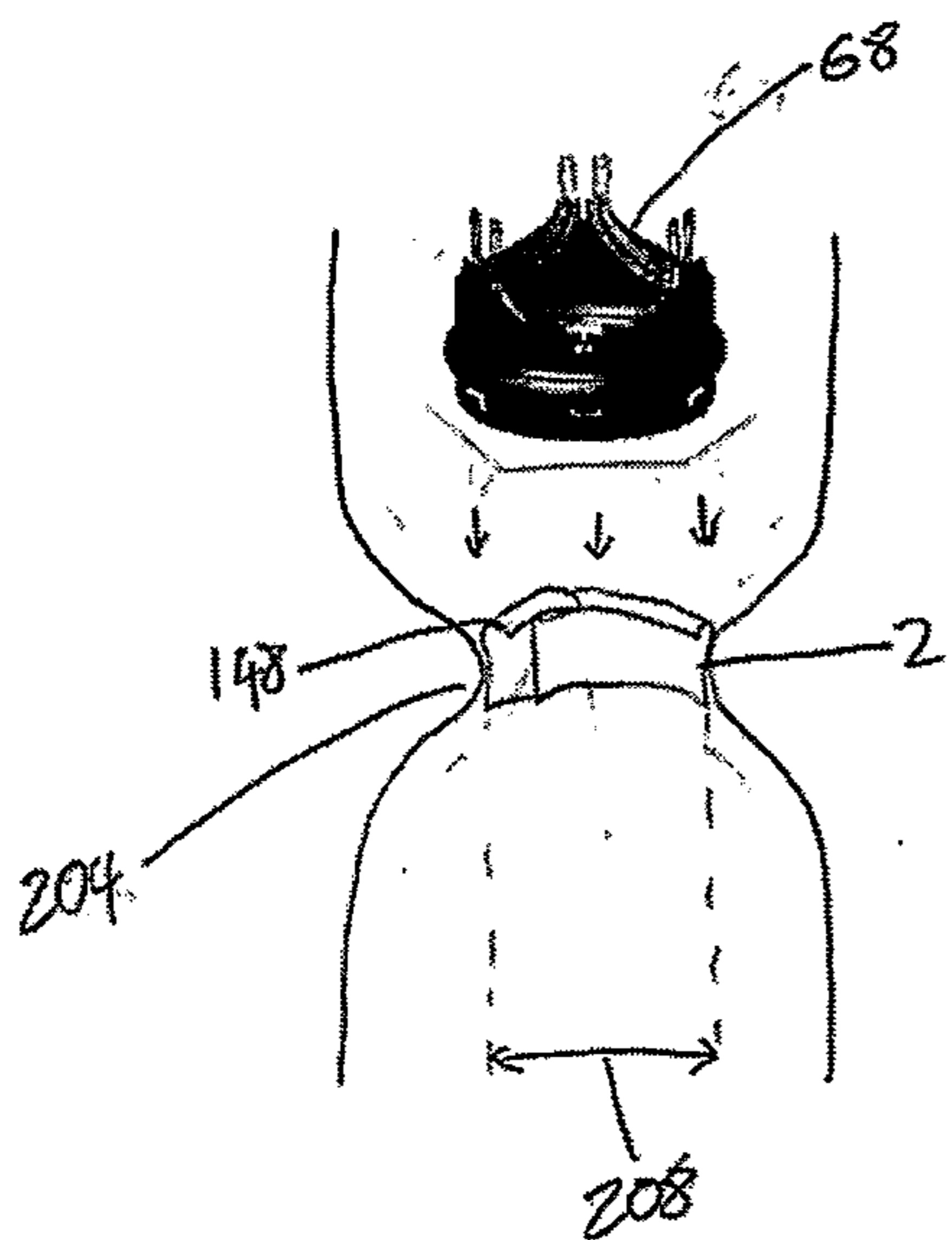

FIG. 69

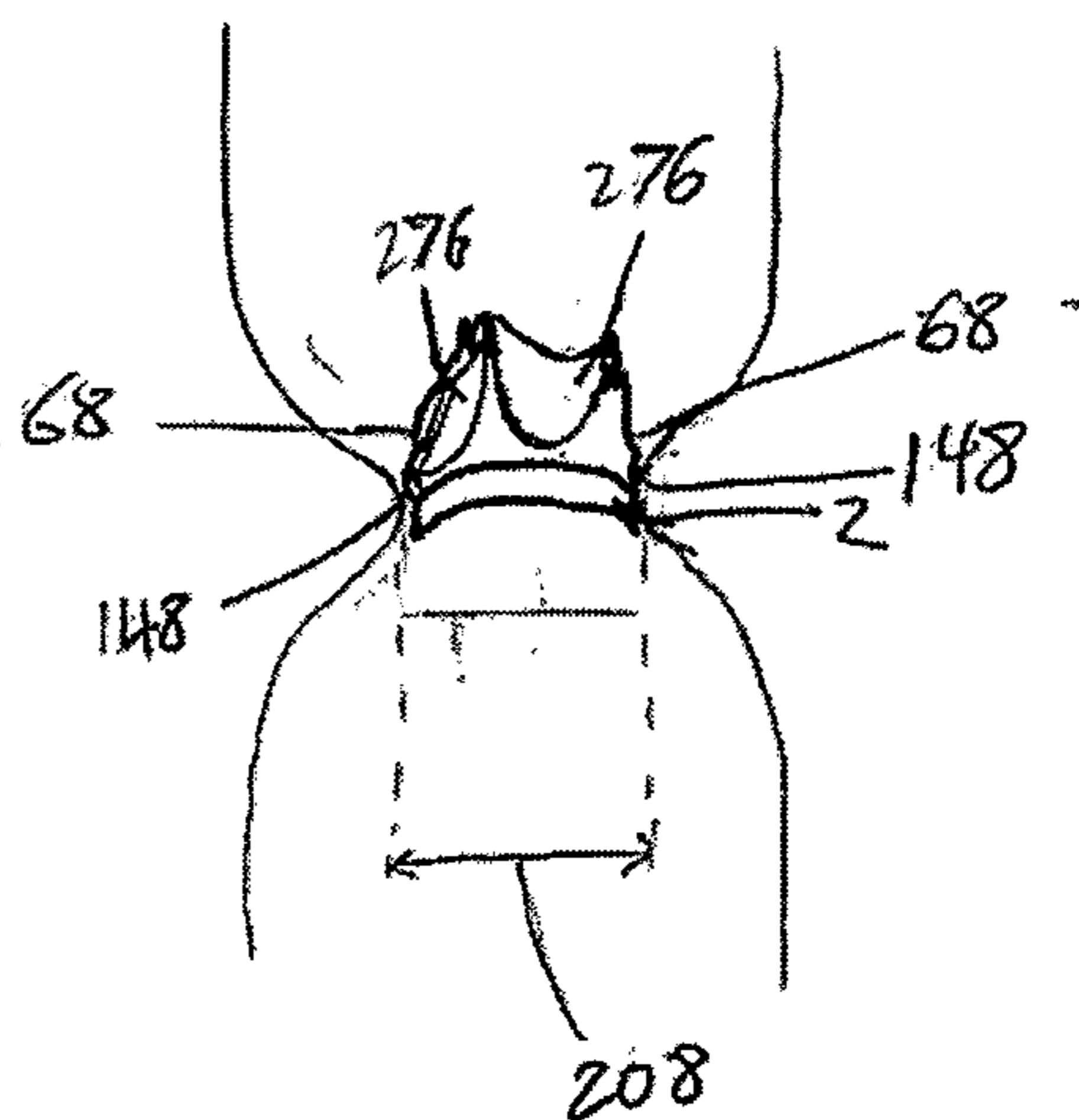

FIG. 70

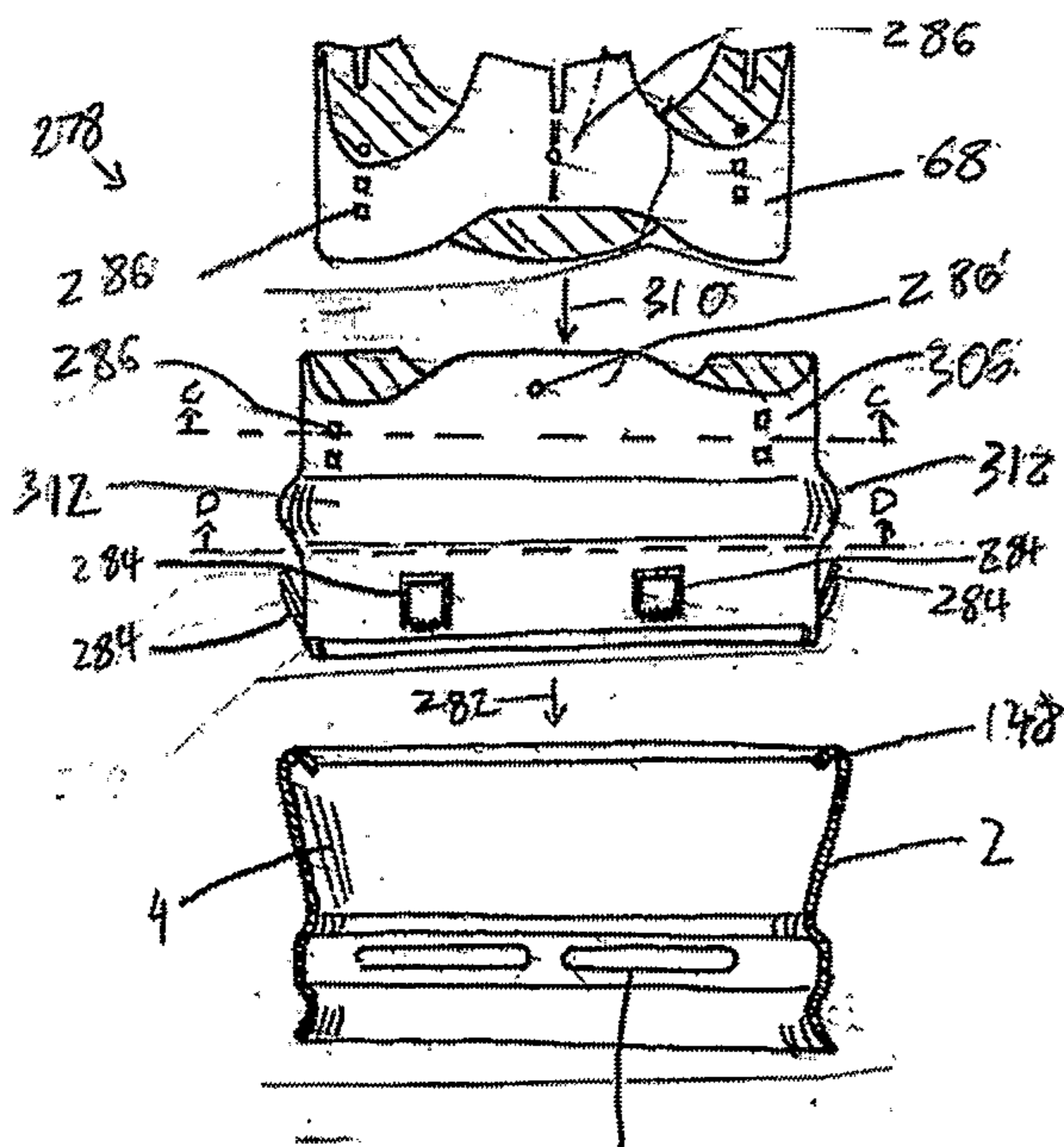

FIG. 78

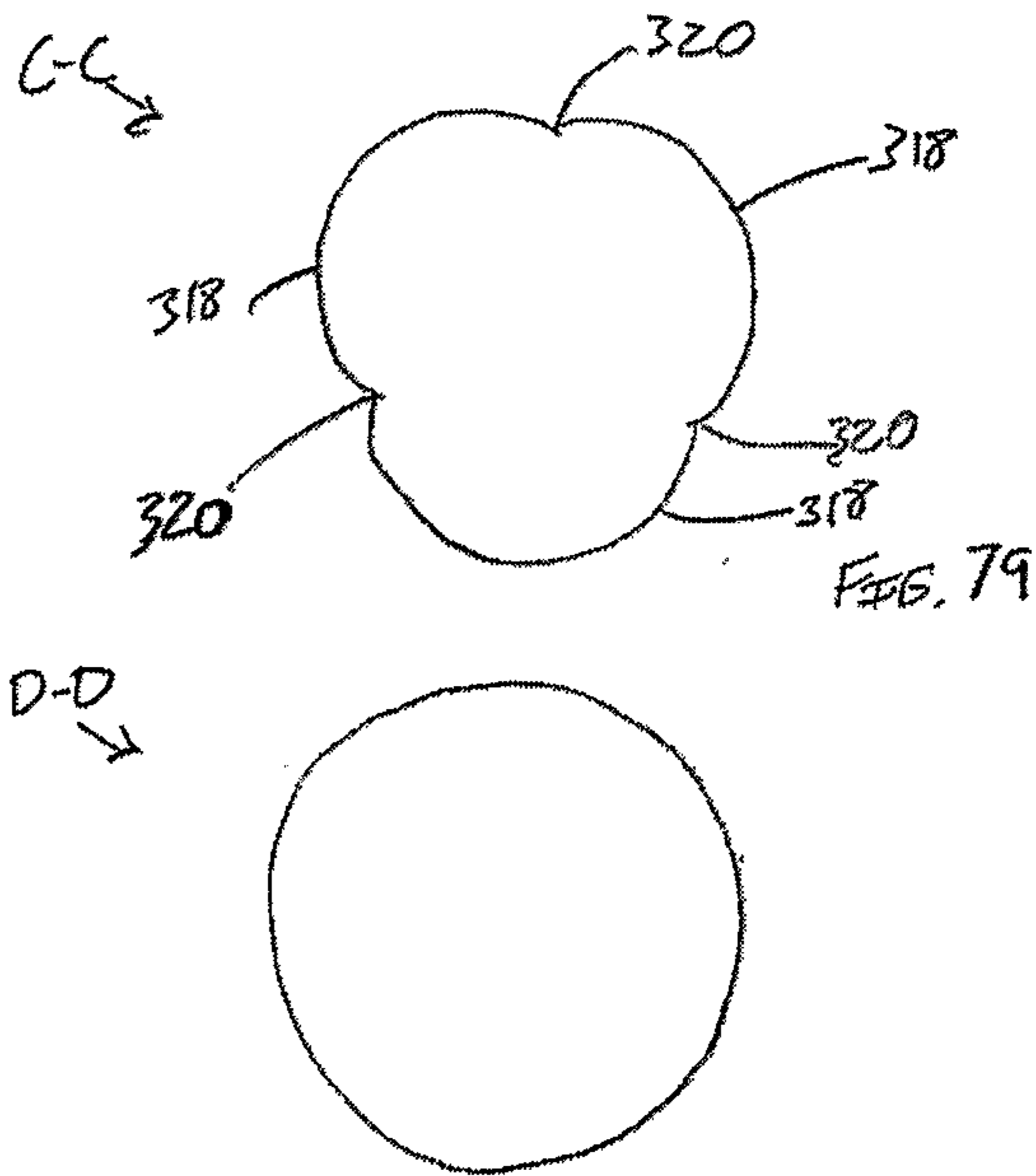

FIG. 80

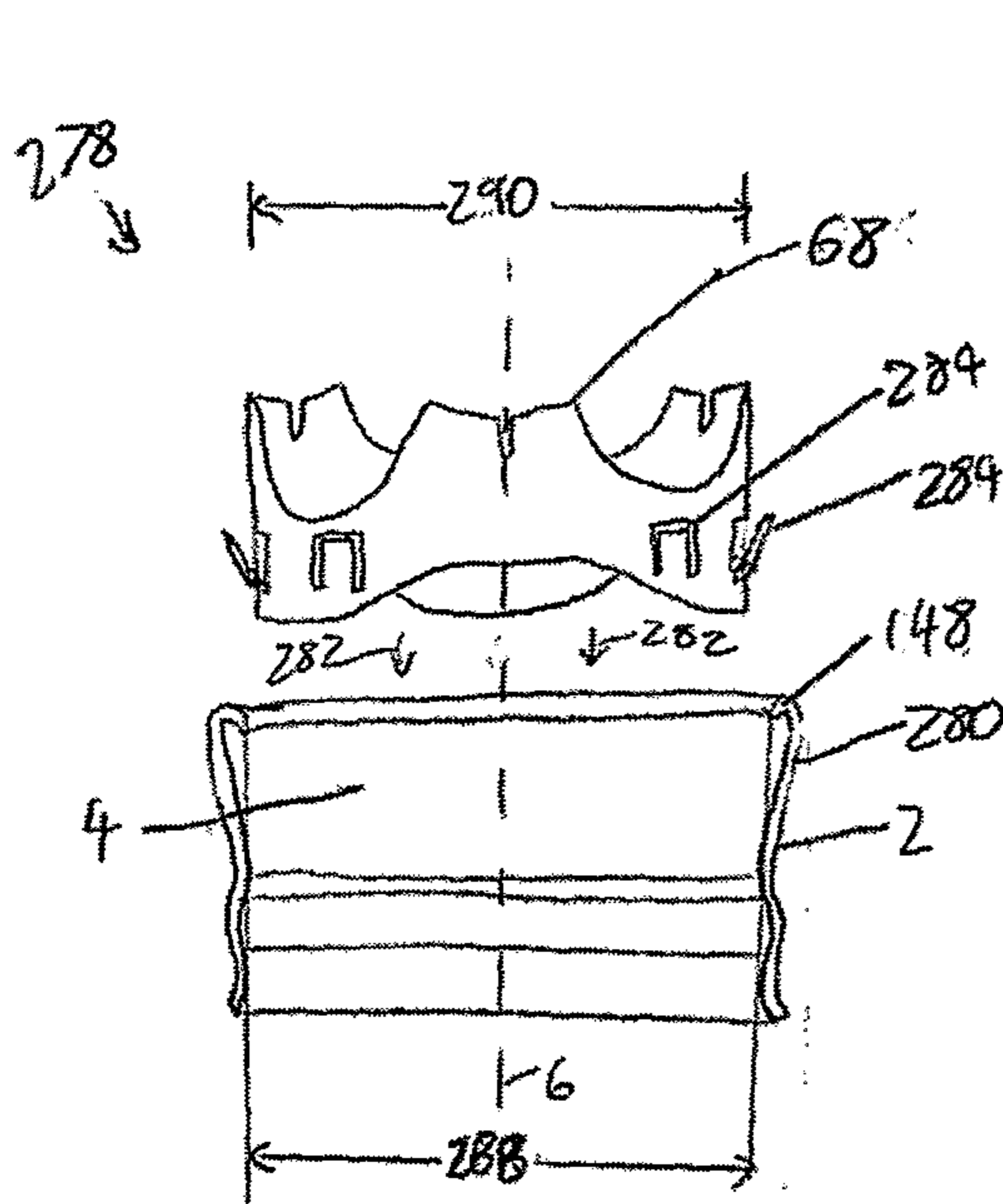

FIG. 71

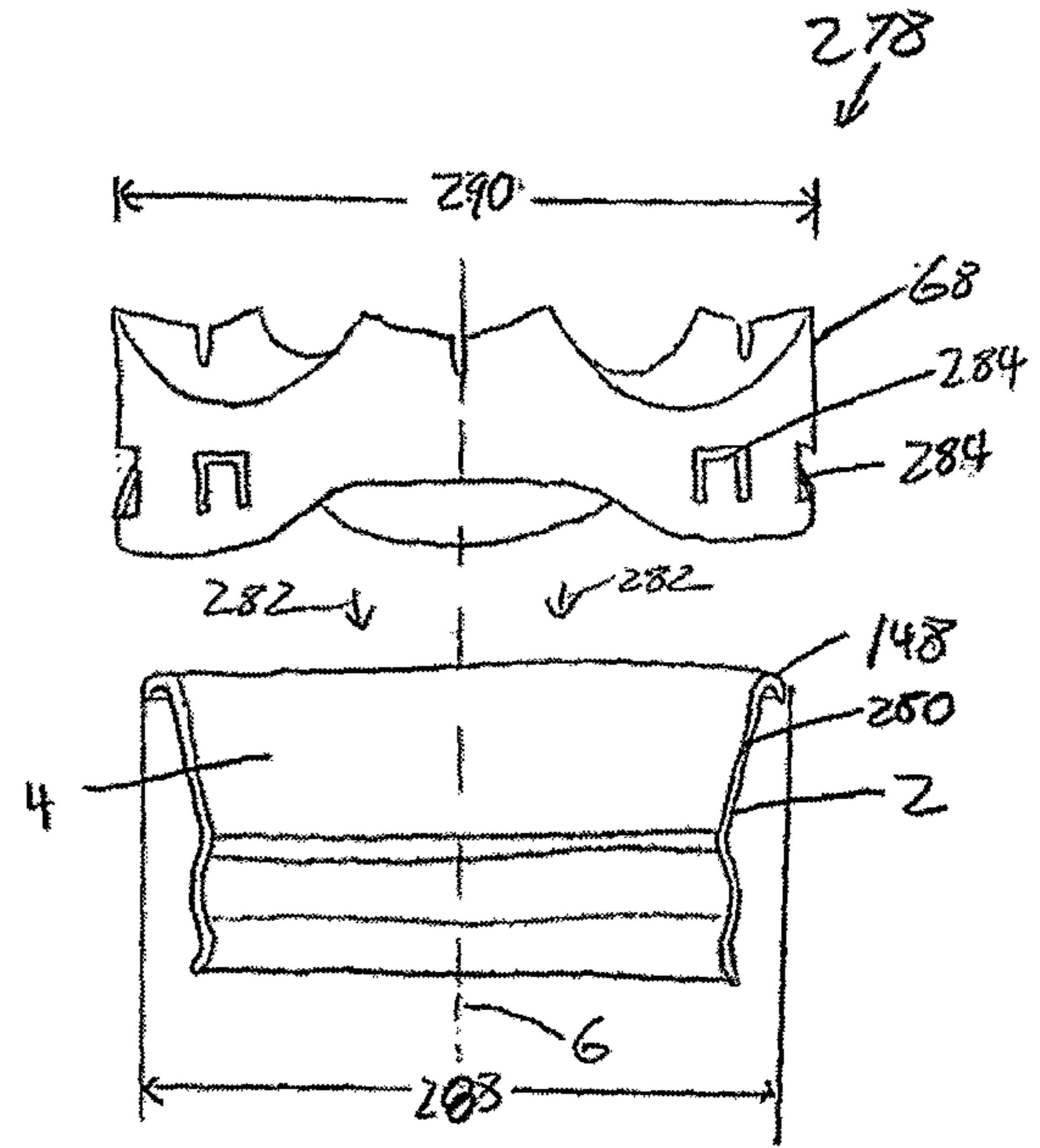

FIG. 72

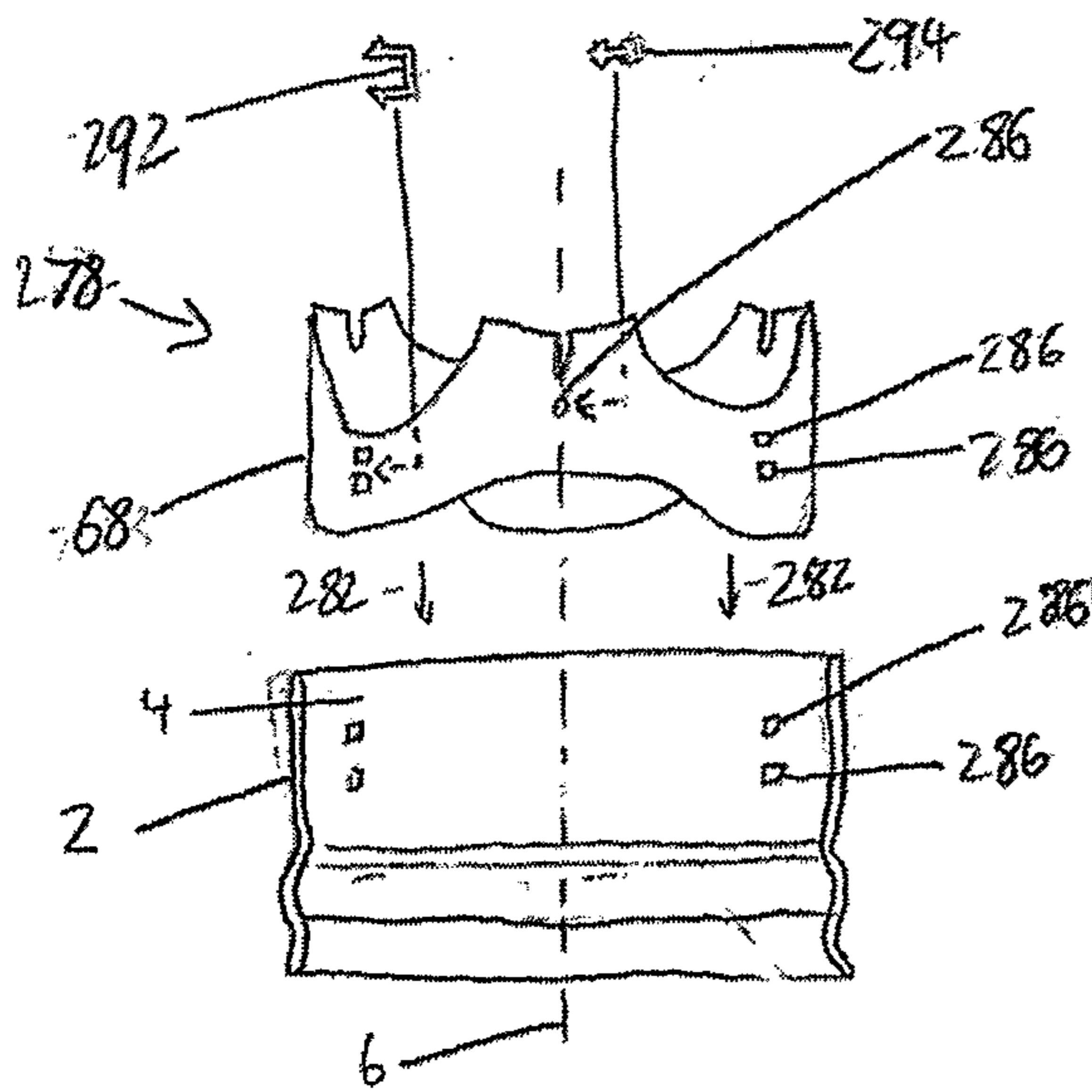

FIG. 73

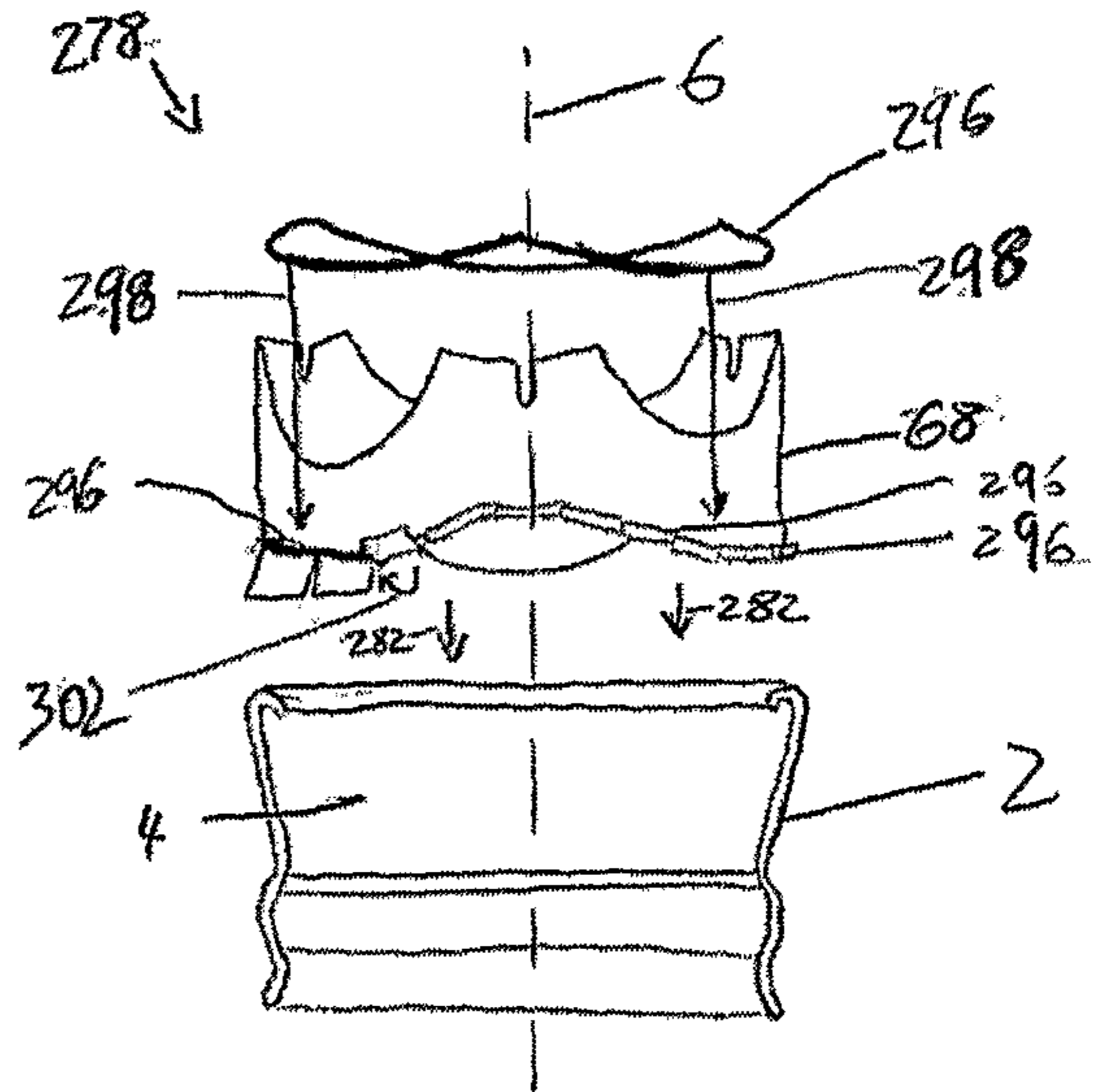

FIG. 74

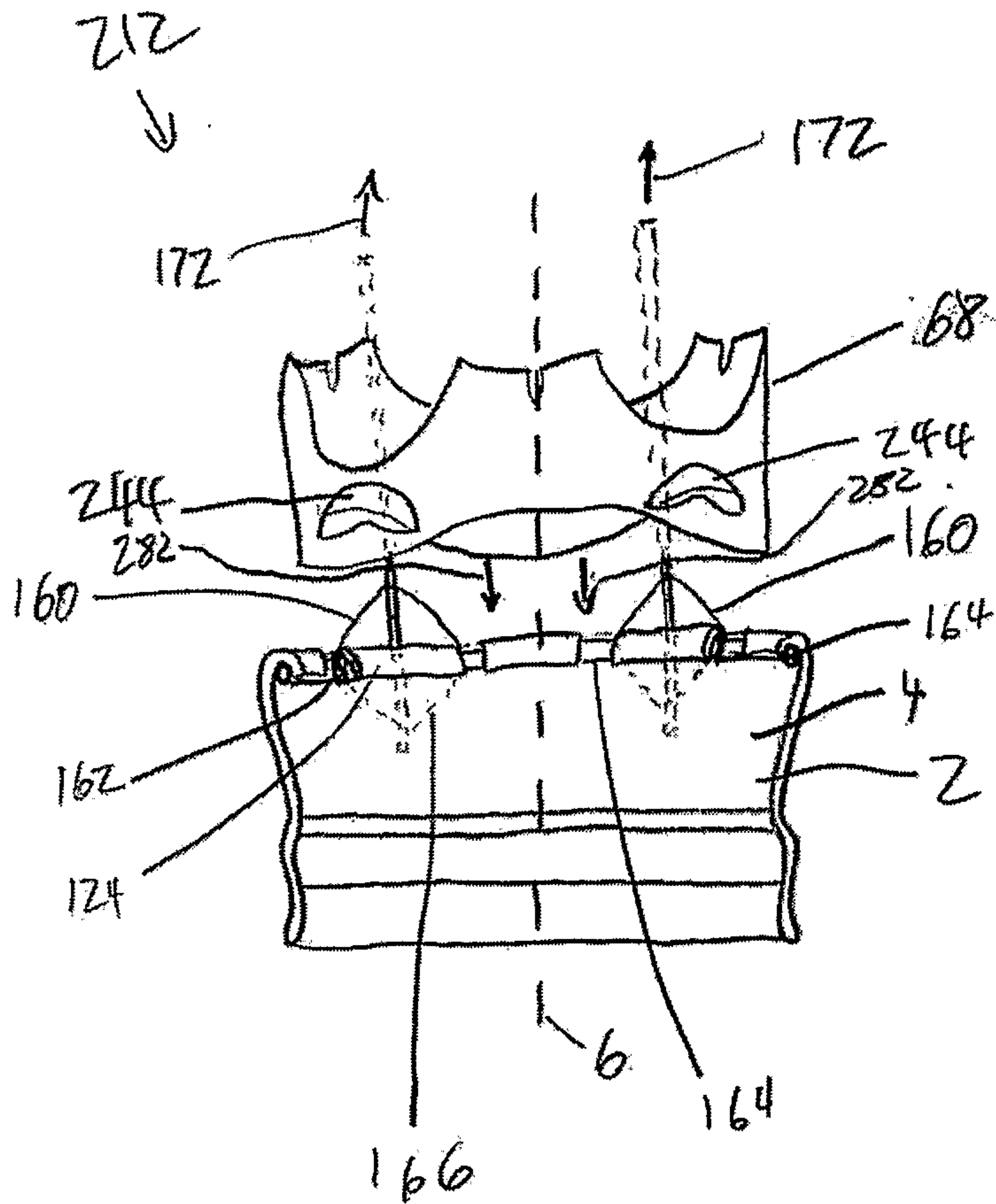

FIG. 75



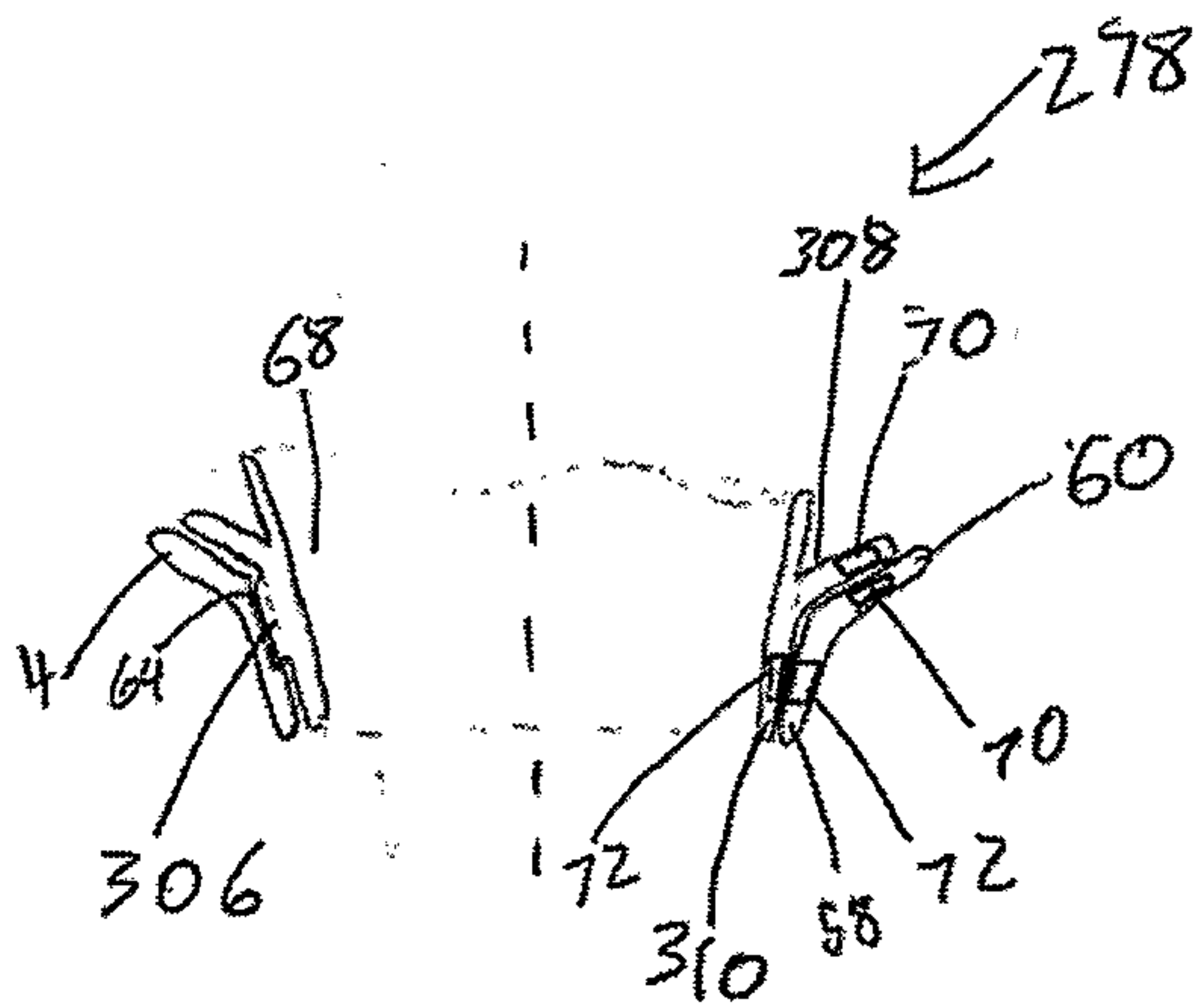

FIG. 76

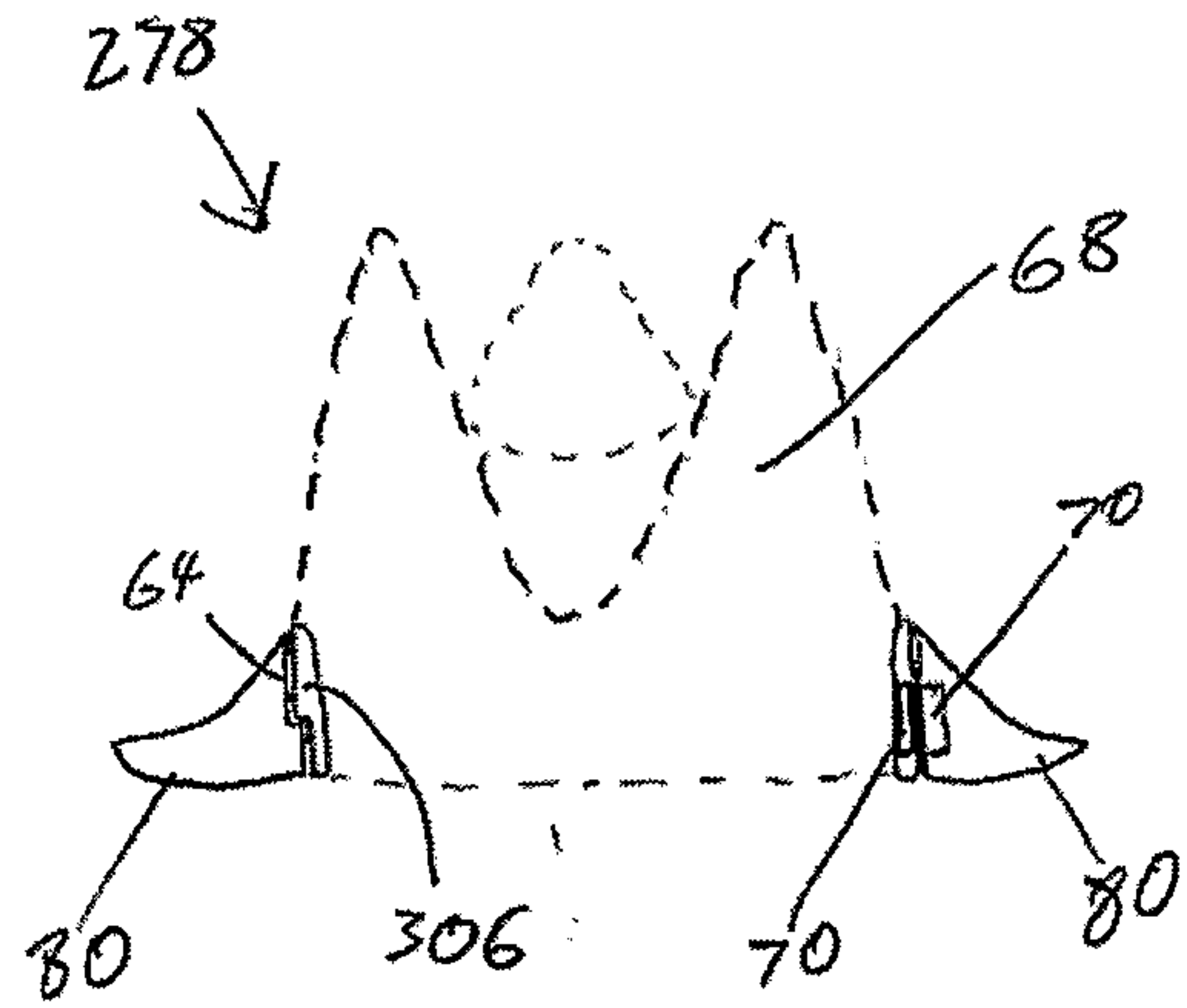

FIG. 77

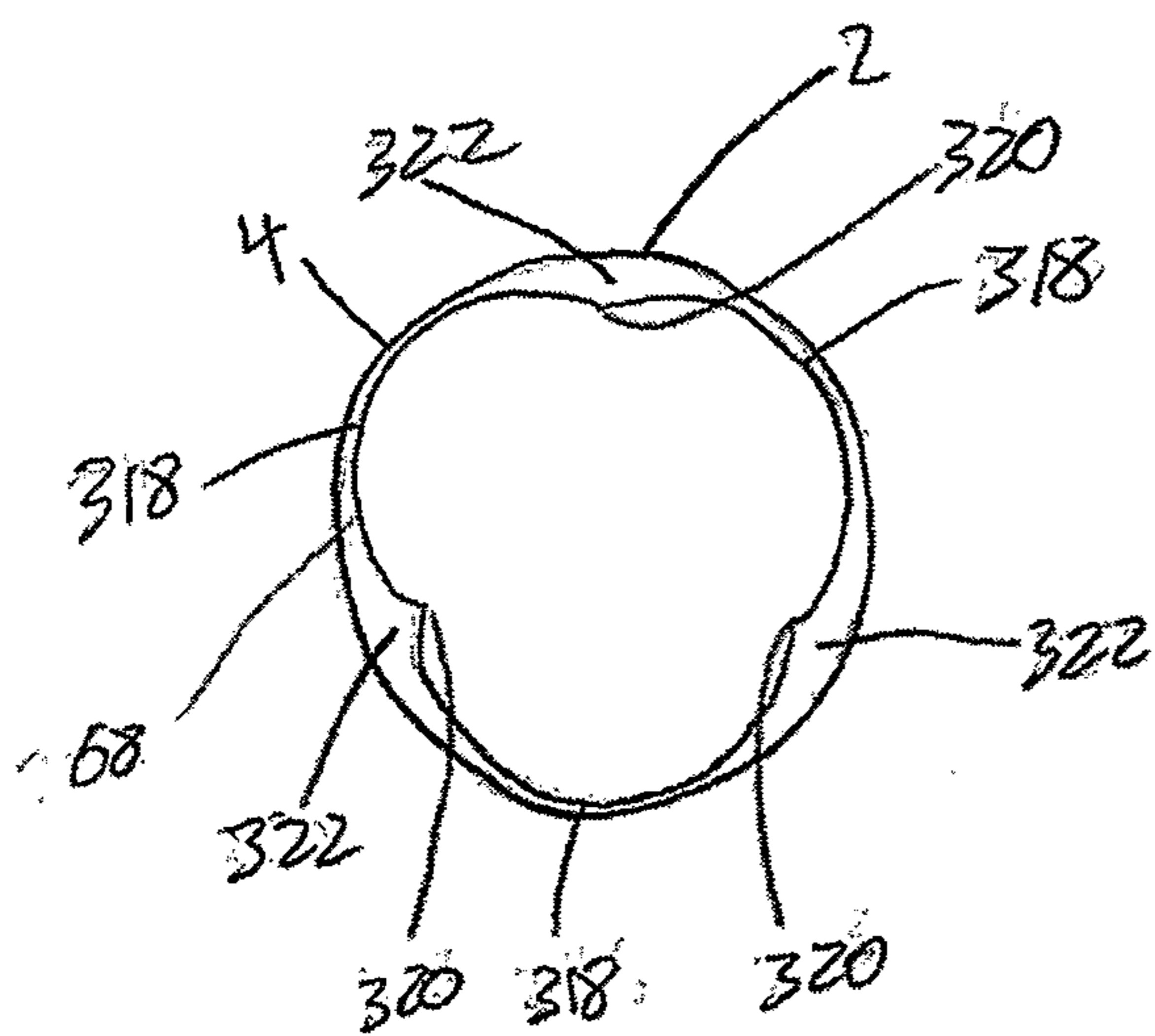

FIG. 81

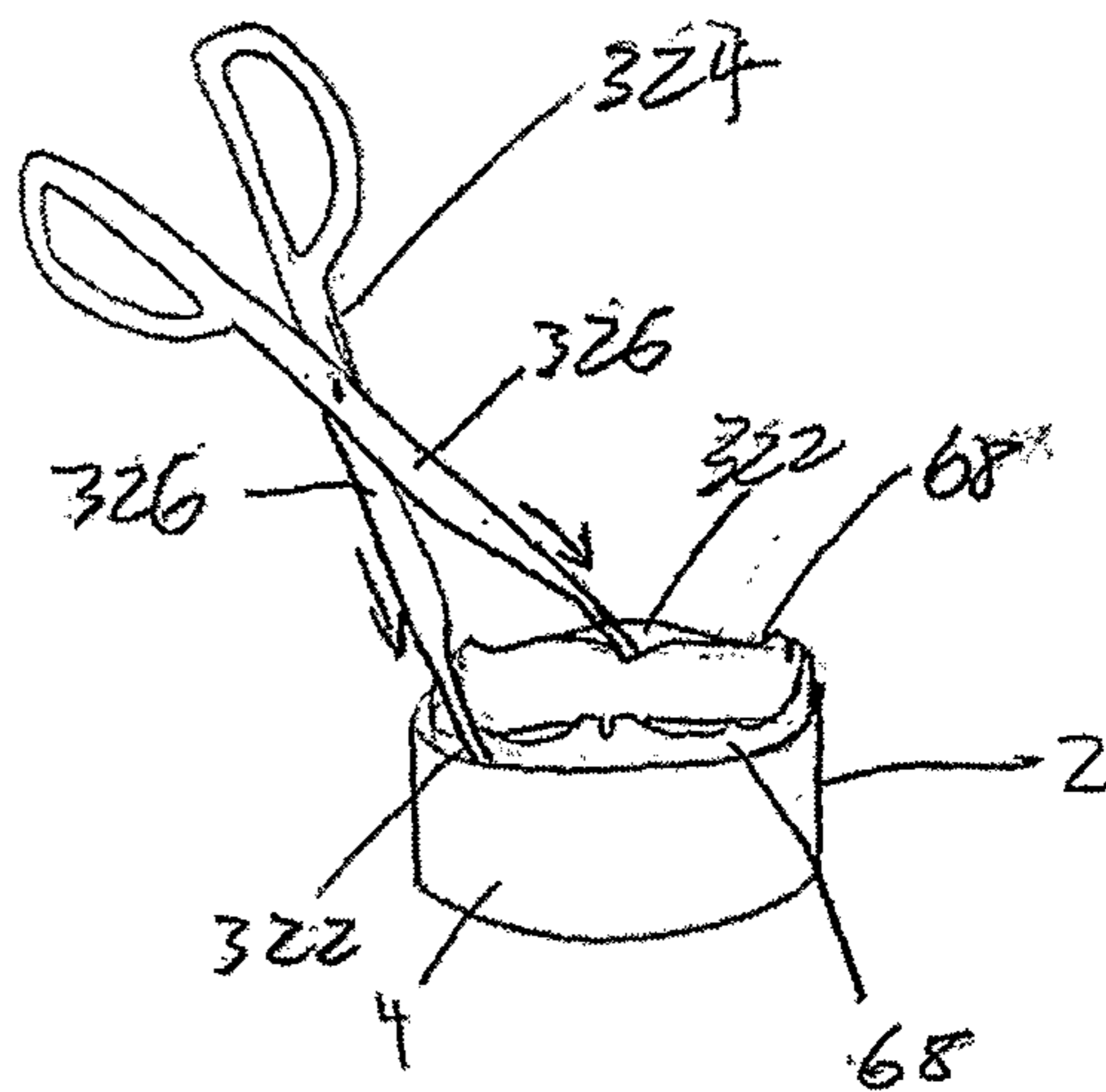

FIG. 82

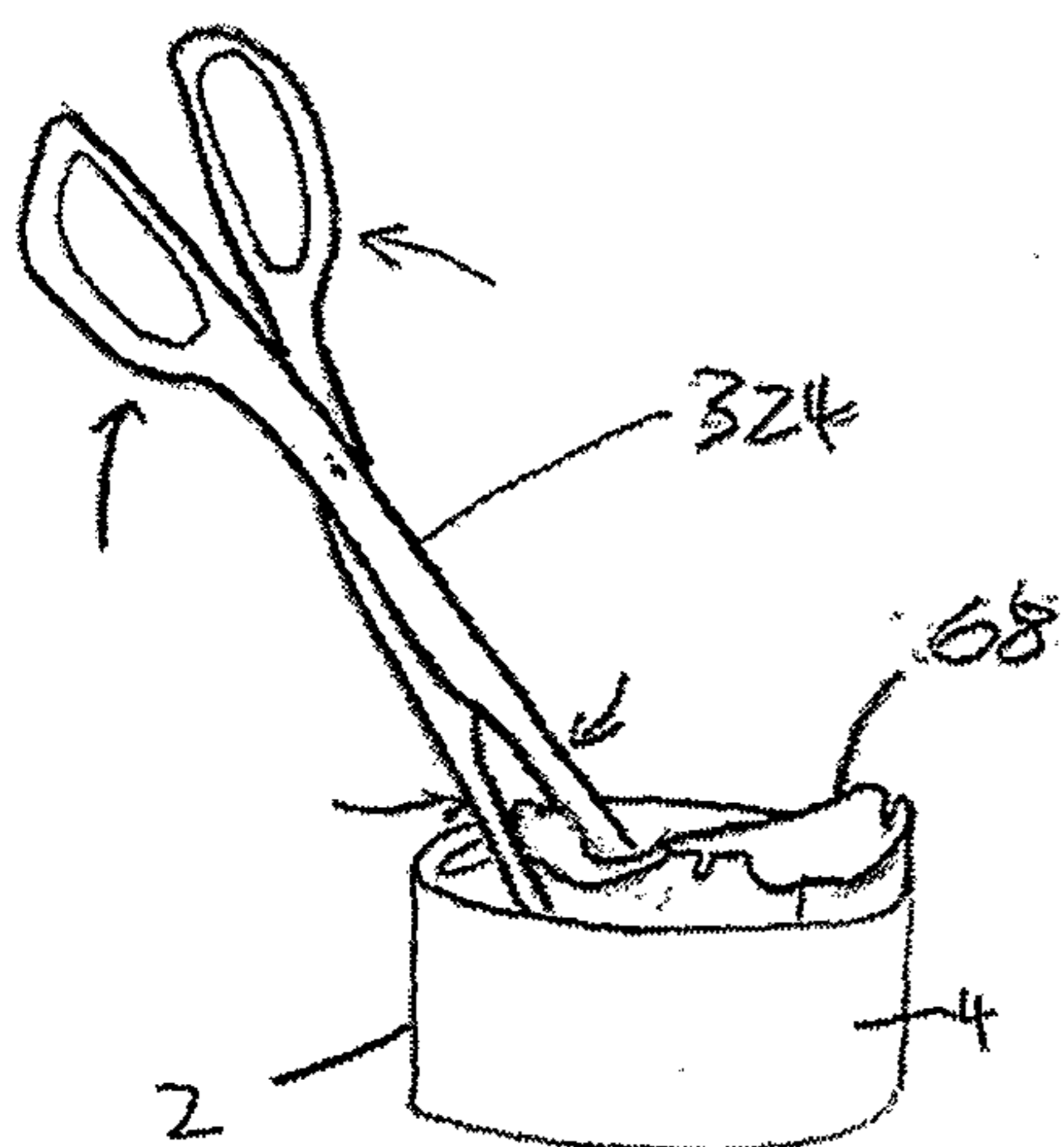

FIG. 83

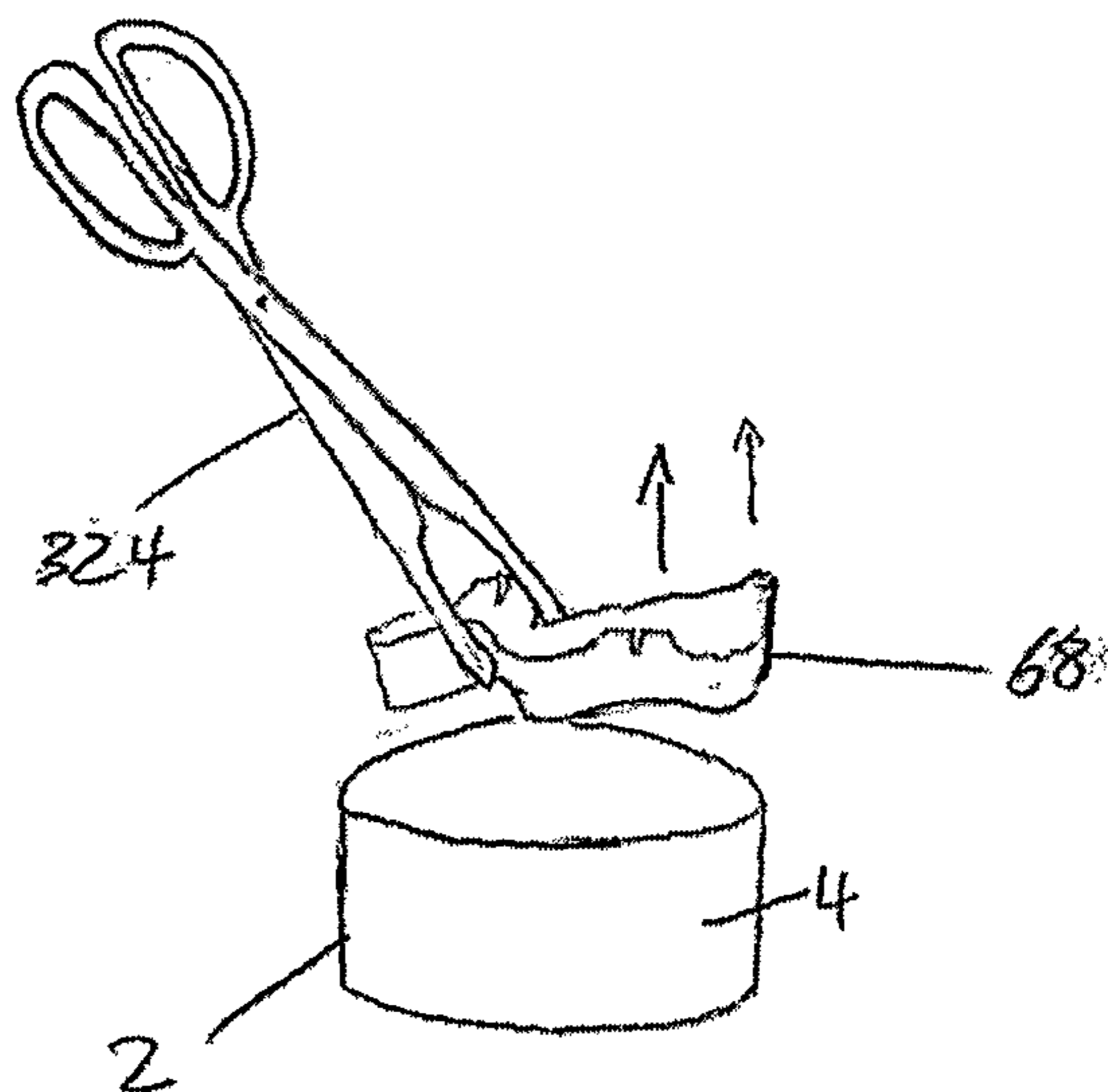

FIG. 84

