

(19) World Intellectual Property
Organization
International Bureau



(43) International Publication Date
8 January 2004 (08.01.2004)

PCT

(10) International Publication Number
WO 2004/002364 A2

- (51) International Patent Classification⁷: A61F (74) Agents: COHEN, Jerry et al.; Perkins, Smith & Cohen, LLP, One Beacon Street, Boston, MA 02108 (US).
- (21) International Application Number: PCT/US2003/020450 (81) Designated States (*national*): AE, AG, AL, AM, AT, AU, AZ, BA, BB, BG, BR, BY, BZ, CA, CH, CN, CO, CR, CU, CZ, DE, DK, DM, DZ, EC, EE, ES, FI, GB, GD, GE, GH, GM, HR, HU, ID, IL, IN, IS, JP, KE, KG, KP, KR, KZ, LC, LK, LR, LS, LT, LU, LV, MA, MD, MG, MK, MN, MW, MX, MZ, NI, NO, NZ, OM, PG, PH, PL, PT, RO, RU, SC, SD, SE, SG, SK, SL, SY, TJ, TM, TN, TR, TT, TZ, UA, UG, US, UZ, VC, VN, YU, ZA, ZM, ZW.
- (22) International Filing Date: 27 June 2003 (27.06.2003)
- (25) Filing Language: English
- (26) Publication Language: English
- (30) Priority Data: 60/392,332 27 June 2002 (27.06.2002) US (84) Designated States (*regional*): ARIPO patent (GH, GM, KE, LS, MW, MZ, SD, SL, SZ, TZ, UG, ZM, ZW), Eurasian patent (AM, AZ, BY, KG, KZ, MD, RU, TJ, TM), European patent (AT, BE, BG, CH, CY, CZ, DE, DK, EE, ES, FI, FR, GB, GR, HU, IE, IT, LU, MC, NL, PT, RO, SE, SI, SK, TR), OAPI patent (BF, BJ, CF, CG, CI, CM, GA, GN, GQ, GW, ML, MR, NE, SN, TD, TG).
- (71) Applicants and (72) Inventors: LEVINE, Robert, A. [US/US]; 60 Longwood Avenue, #1010, Brookline, MA 02446 (US). HUNG, Judy, W. [US/US]; 54 Oakwood Road, Newtonville, MA 02460 (US). GUERRERO, J., Luis [US/US]; 49 Cross Street, Norton, MA 02766 (US). VLAHAKES, Gus, J. [US/US]; 17 Juniper Road, Weston, MA 02493 (US).

[Continued on next page]

(54) Title: SYSTEMS FOR AND METHODS OF ATRIOVENTRICULAR VALVE REGURGITATION AND REVERSING VENTRICULAR REMODELING

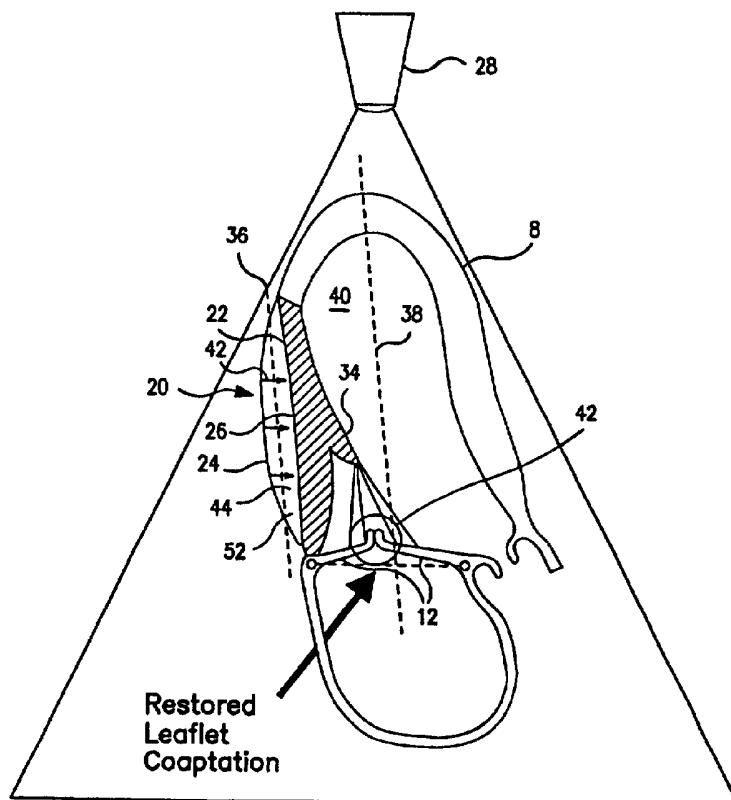

(57) Abstract: Methods of and devices for restoring the normal geometry of a heart, including but not limited to the structures supporting the atrioventricular valves. The techniques and devices described herein operate on the principle of displacement, both active and passive, to reverse cardiac remodeling and limit ischemic atrioventricular valve regurgitation.

WO 2004/002364 A2



Published:

— without international search report and to be republished upon receipt of that report

For two-letter codes and other abbreviations, refer to the "Guidance Notes on Codes and Abbreviations" appearing at the beginning of each regular issue of the PCT Gazette.

SYSTEMS FOR AND METHODS OF ATRIOVENTRICULAR VALVE REGURGITATION AND REVERSING VENTRICULAR REMODELING

5

FIELD OF THE INVENTION

The present invention relates generally to methods and devices for reversing ventricular remodeling and correcting valvular dysfunction and, more specifically, for locally addressing and reorienting ventricular tissues. Several minimally invasive techniques and adjustable devices are described.

10

BACKGROUND OF THE INVENTION

Patients with ischemic heart disease experience a wide range of pathological changes. Some of these include ventricular dilatation, dilatation of the mitral annulus, papillary muscle displacement and tethering, papillary infarcts, segmental and global ventricular dysfunction. The mitral valve function and competency rests on the fine geometric and functional integrity of its supporting structures.

15

When the left ventricle distorts due to dilatation or scarring from myocardial infarction, the papillary muscles are tethered, thus preventing adequate closure of the mitral valve. The left ventricle has two papillary muscles. Both originate from the left ventricular free wall. The anterior papillary muscle is attached to the anterior wall of the left ventricle, close to its lateral border. The posterior papillary muscle originates from the posterior wall, near the junction of the interventricular septum. The mitral valve closure is effected by the apposition of its leaflets. Papillary muscle tethering has been shown to be one of the important mechanisms resulting in mitral valve incompetency, and failure of leaflet apposition. Ischemic mitral regurgitation accounts for significant mortality and morbidity in patients with heart disease (it doubles the late mortality after heart attack and after bypass surgery if unrepaired).

20

25

30

Figure 1 illustrates the fundamental problem of ventricular dilatation in a heart 2 and its relation to atrioventricular valve regurgitation. (Please note that the view presented

is inverted from the normal anatomic presentation, as the heart depicted in this and other figures herein are presented as observed in an ultrasound image, with the apex 4 displayed on top because it is closest to the ultrasound transducer.) A damaged muscular wall 6 of a left ventricle 8, the heart's primary pumping chamber, becomes distorted and bulges outward from the center of the ventricular cavity 9. This displaces the papillary muscle 10, to which mitral valve leaflets 12 are anchored by a network of tendinous chords 14, in turn pulling on the leaflet tips and preventing proper meeting (*i.e.*, coaptation) of the leaflets. This results in improper closure and mitral regurgitation from the left atrium 16 back into the left ventricular cavity 9 across the mitral annulus 18. Such regurgitation can produce heart failure, rhythm disorders, sudden death, and a predisposition to lethal heart valve infections. Even in patients in which ventricular remodeling has not yet resulted in significant atrioventricular valve regurgitation, dilatation causes a greater ventricular cavity volume and a commensurate increase in pumping load on the heart.

Previous work that addressed ischemic mitral regurgitation includes:

(a) Czer et al. documented that revascularization (Coronary Artery Bypass Grafting) alone does not improve mitral regurgitation. In a study of 2000 patients who underwent coronary artery bypass surgery, uncorrected mitral regurgitation nearly doubled the risk of late death.

(b) Mitral valve annuloplasty addresses the mechanism of annular dilation as a cause of ischemic mitral regurgitation. Mitral ring annuloplasty involves sewing a prosthetic mitral ring around the mitral annulus to reduce annular size and force the leaflets of the mitral valve to close better. Clinical observations suggest, however, that it does not always reduce the degree of MR because it does not correct for improper heart geometry. In addition, annuloplasty techniques involve opening the heart, an invasive procedure with significant associated risk, and requires placing the patient on cardiopulmonary bypass (stopping the heart and opening it to insert the ring while using an artificial pump to bypass the heart and lungs). To assess the efficacy of a procedure, one must examine mitral valve function once the heart has been released fully from cardiopulmonary bypass. If the surgical annuloplasty procedure failed to accomplish its objective, then one must reinstitute cardiopulmonary bypass to readjust the ring position. Repetitive cycles of

cardiopulmonary bypass increase the already significant morbidity and mortality of surgical mitral ring annuloplasty. Because of these associated risks, surgical mitral ring annuloplasty is often not offered to the sickest patients who might otherwise gain the greatest benefit from the procedure.

5 (c) Surgical techniques have been advocated for surgically grasping the valve leaflets and stitching them together with a suture or other fastener. There are several difficulties that limit the ability to practice those inventions successfully. In patients with sufficient MR to warrant such procedure, the leaflets are initially misaligned, limiting or precluding the ability of a single device to bring the leaflet tips into juxtaposition in order
10 to suture or fasten them together. Also, in order to be effective, the proposed suction device for grabbing the leaflets must withdraw blood extremely rapidly; unless blood is reinfused immediately, hypotension can ensue. A means for stabilizing the leaflet surfaces must also be utilized, otherwise the suture or staple intended to fasten the leaflets may instead displace them. Also, when the leaflets are overstretched, suturing may not be
15 successful as suturing may increase the tension on the leaflets.

(d) Other ventricular remodeling techniques and patents have been introduced for restraining ventricular size, such as pericardial clamps or harnesses, in some cases having balloons or stakes affixed to them. Such devices encircle the heart in global ventricular dilatation and do not address specific segmental pathology, (*i.e.*, they do not provide
20 selectivity of the target points nor adaptability.) Other devices include passive tensor mechanisms that are inserted through the heart and have as their goal the reduction of ventricle diameter at that point. Permanently implanting components traversing the chambers of the heart is, again, a quite invasive treatment. And these approaches lack precise targeting or sturdy fixation. Rather, such techniques and/or devices have targeted a
25 circumferential change in ventricular geometry versus a specific regional change in displacement, tension, and force. Precise targeting and correction of the stress strain and displacement interactions are specifically important for the intricate geometry of atrioventricular valves.

Thus, what is needed are methods and devices for treating ventricular remodeling and atrioventricular regurgitation by locally addressing the geometric distortion of the supporting structures of the ventricle.

It would additionally be desirable if such a technique could be performed without requiring cardiopulmonary bypass, the need for which frequently influences surgeons not to repair valves, particularly in patients who are more seriously ill and could benefit most from this repair, but are at greatest risk from prolonged bypass.

Further, because damage to heart geometry is also progressive, initial success in reducing regurgitation and/or remodeling is often followed by its recurrence. It would therefore be desirable to employ an approach to addressing these conditions that is adjustable over time.

SUMMARY OF THE INVENTION

The present invention provides methods of and devices for restoring the normal geometry of a heart, including but not limited to the structures supporting the atrioventricular valves. The techniques and devices described herein operate on the principle of displacement, both active and passive, to reverse cardiac remodeling and limit ischemic atrioventricular valve regurgitation.

Preferred embodiments of the invention include minimally invasive methods (*e.g.*, thoracoscopy) not requiring open-heart surgery or cardiopulmonary bypass. They may be performed in conjunction with or without alternative therapies. More than one location of the heart may be simultaneously treated by the invention.

The present invention allows papillary muscles to be repositioned and thus the normal atrioventricular valve geometry to be restored in order to relieve the tension on the leaflets and allow them to close effectively. It should be noted that, despite the specific embodiments described herein that pertain to mitral valve regurgitation of the left ventricle, the methods and devices described herein are equally applicable to address valve regurgitation on the right side of a heart and dilatation of other heart chambers, and that the term 'papillary muscle', as used herein, means any connecting structure having comparable

functionality as the papillary muscle of the left ventricle. Also, use of the 'normalize' with respect to cardiac geometry means moving towards normal and not necessarily complete restoration of normal cardiac geometry. Similarly, certain specific embodiments and descriptions below use the term 'exterior wall segment' to refer to a region of the heart proximate the papillary muscle or extended to the base (*i.e.*, junction of ventricle and atrium), but the term is otherwise not intended to be so limited.

Intraoperative observations suggest that force or pressure applied outside papillary muscle can eliminate atrioventricular valve regurgitation (AVR). The present invention provides devices for placement in a longitudinal plane along a portion of the papillary muscle that exert such forces in three-dimensional space (*i.e.*, causing displacement both normal to and radially from said longitudinal plane.)

The devices for treating AVR generally include a compression member acting on an exterior wall segment of the heart to achieve the displacement of the exterior wall segment inward and toward the center line of the ventricular cavity of the heart so as to normalize papillary muscle geometry and improve leaflet coaptation. In preferred embodiments, the devices are reversibly collapsible or furlable for easier delivery to the heart wall attachment site.

In one embodiment, the displacement is achieved by adjustably inflating an inflatable reservoir disposed between the compression member and a buttressing portion of the device that resists expansion away from the heart, thereby forcing the compression member to move the heart wall segment. The reservoir may also be deflated and re-inflated, either intermittently (*e.g.*, in separate operations at different points of time) or more cyclically, such as in temporal coordination with the electrical activity of the heart. The inflation may be achieved by pumping an inflation fluid or gel from a supply source to the reservoir. Such devices may be atraumatically fastened to the exterior wall by any conventional means, such as suturing to, or beneath, the top layer of the pericardium surrounding the heart.

Echocardiographic imaging may aid in performance of any of the procedural steps described herein, such as guiding the placement of the devices, or monitoring and/or adjusting the displacement of the wall segment the devices effect. Such imaging is also

useful in designing the device to have a compressive member contoured to achieve a displacement unique to the portion of the exterior wall segment intended to be displaced.

In another embodiment, the displacement is achieved by filling a fillable region between the compressive member and the buttressing portion with a stuffing. The stuffing
5 may comprise engineered tissue that stiffens in the fillable region (*e.g.*, bone or cartilage forming tissues), thereby maintaining the compressive force on the exterior wall segment. A scaffold structure may be employed to initially receive the engineered tissue. A portion of the apparatus may biodegrade over a time period comparable to that required for the engineered tissue to stiffen to the point of independently providing the displacement force
10 required to move the heart wall segment so as to normalize the papillary muscle geometry and improve leaflet coaptation.

In an alternative embodiment, the engineered tissue includes artificial muscle composed of conducting polymers that actively contract and relax in response to electrical triggering, thereby cyclically moving the exterior wall segment through varying degrees of
15 displacement.

The buttressing portion of the device may comprise a patch or external surface of a pouch, each formed of known biocompatible materials having sufficient stiffness to limit expansion away from the heart as a result of the inflation or filling forces.

The present invention further provides an apparatus and method for reducing
20 regurgitation of an atrioventricular valve of a heart by delivering a material into a muscle wall region of a heart proximate the papillary muscle. The material displaces a portion of said muscle wall region inward and toward the center line of the ventricular cavity and thus normalizes papillary muscle geometry and improves leaflet coaptation. Suitable materials include hydrogels or nickel titanium alloys (*e.g.*, NitinolTM) that substantially
25 retain their shape after delivery. The material may be encapsulated in a structure implanted within the muscle wall, such as, for example, a balloon or a cellular matrix comprised of fibroblasts.

In one embodiment, the material is injected into the muscle wall region, which may be, for example, the tissue plane between the coronary sinus and mitral annulus in the heart. Alternatively, the region could be a location in the base of the heart.

Artisans will readily appreciate that the devices and methods described above for repositioning papillary muscles to limit AVR may be applied more generally in reversing cardiac remodeling in other heart regions.

BRIEF DESCRIPTION OF THE DRAWING

10

The advantages of the present invention will be apparent in the following detailed description of the illustrative embodiments thereof, which is to be read in connection with the accompanying drawing, wherein:

Figure 1 is a cross-sectional view of a heart exhibiting abnormal mitral valve geometry occurring in ischemic mitral regurgitation;

Figure 2 is an illustration of a cross-sectional view of a heart to which an external pouch has been attached;

Figure 3 is an illustration of an embodiment of a pouch or patch device in accordance with the present invention;

Figure 4 is an illustration of an inflatable balloon system in accordance with an embodiment of the present invention;

Figures 5A, 5B are cross-sectional view of the plane between an embodiment of the inventive device and an external heart wall;

Figures 6A-6E are illustrations of an embodiment of the present invention employing conductive polymers as an active displacement mechanism;

Figures 7A, 7B are illustrations of cross-sectional views of a heart to which the device has been attached to additionally address mitral annulus dilatation;

Figures 8A-8D are illustrations of cross-sectional and external views of a heart to which are attached multiple inflatable devices;

Figures 9A-9D are illustrations of deformable devices and cross-sectional views of a heart to which such deformable devices are attached;

Figures 10A,10B are illustrations of cross-sectional views of a heart having a wall into which has been delivered an internal stiffening material;

Figure 11 is an illustration of a heart viewed via an ultrasound image depicting percutaneous delivery of a polymer material and/or encapsulating structure via coronary
5 sinus;

Figure 12 is an exploded view of the region of the heart proximate to the site(s) of material and/or encapsulating structure delivery via a catheter system;

Figure 13 is an illustration of tissue region receiving injection proximate to coronary sinus and annulus;

10 **Figure 14** is an illustration of tissue region receiving injection proximate to coronary sinus and base of the heart; and

Figure 15 is an illustration of a catheter system used to inject a biocompatible material within an encapsulating shell.

15 **DETAILED DESCRIPTION OF PREFERRED EMBODIMENTS**
OF THE INVENTION

Preferred embodiments of the present invention will now be described with reference to the several figures of the drawing.

In one embodiment, illustrated in **Figure 2**, the present invention provides a device
20 **20** that is secured to an exterior wall segment **22** of the epicardium of a left ventricle **8**. Device **20** includes a pouch **24** or a patch (not shown) composed of expanded PTFE or a polyester such as Dacron™ or another known biocompatible material, provided it displays sufficient buttressing properties as described below. Device **20** includes a compression member **26** (e.g., a surface) in contact with exterior wall segment **22**. The
25 compression member may comprise a surface of the pouch **24**. Alternatively, in patch configurations, the compression member may be an outer surface of an inflatable balloon reservoir. In various embodiments of the present invention described below, the compression member **26** comprises any surface, including non-contiguous surfaces and surfaces defined by engineered cellular material and/or conductive polymers, that serve to
30 deform or move a heart muscle tissue. The surface may additionally be countoured to

correspond to the wall segment it is to contact. Prior to implantation, the heart wall may be imaged using an ultrasound transducer **28** in echo cardiography, and a contoured surface may then be pre-formed, for example, through stereolithographic manufacturing.

Device **20** is secured to the exterior wall segment **22** through known means, such as
5 sutures, staples, tined anchors or the like.

Figure 3 depicts device **20** as an elliptical object lying on the exterior surface of left ventricle **8**, fastened by sutures **30**. The patch or pouch may have an extended edge **32** or a ring to facilitate placement of sutures. The patch or pouch may also be secured beneath the top layer of the pericardium surrounding the heart.

10 Returning again to **Figure 2**, to treat AVR, device **20** is positioned over a damaged papillary muscle **34**. If a discrete infarct exists, it is preferable to cover the region of the infarct (which may be identified by ultrasound), however placement is not limited to damaged or deformed tissue. The long axis **36** of the pouch or patch and compression member **26** is aligned parallel to the centerline **38** of the ventricular cavity **40**. The edges of
15 the patch or pouch device **20** are sewn to the heart wall, with care taken to avoid including any coronary blood vessels exposed on this surface. In order to avoid occluding coronary blood flow, one approach that may be taken is to place a semi-rigid protective cover over the coronary artery. Another approach is to not suture the device to the heart wall in that area. The resistance the coronary artery itself provides is sufficient to prevent occlusion.
20 If the heart wall tissue is determined through standard testing to have limited viability, it is obviously less important to avoid possible occlusion than if the heart muscle is viable muscle.

The device also includes a displacement mechanism for moving the compression member **26** inward (in the direction of arrow **42**) and toward the centerline **38** of the
25 ventricular cavity **40**. The movement of compression member **26** in turn moves papillary muscle **34** into a more normal geometry, and results in an improvement in coaptation **42** between mitral leaflets **12**. In the embodiment of **Figure 2**, the displacement mechanism comprises an inflatable reservoir **44**, such as, but not limited to, a shaped balloon.

Figure 4 illustrates a preferred embodiment of device **20**, which is comprised of an
30 outer Dacron buttressing layer **46**, an inner layer comprising compression member **26**, and

an inflatable reservoir such as balloon 48 serving as a displacement mechanism. **Figures 5A and 5B** present cross-sectional views of alternative embodiments of device 20. In **Figure 5A**, inflatable balloon 48 is surrounded by a pouch 24 whose outer surface comprises the buttressing layer 46, and whose inner layer comprises the compression member 26. In **Figure 5B**, a surface of the inflatable balloon 48 itself comprises the compression member 26, and the balloon 48 is covered by a patch 50 having a surface comprising the buttressing layer 46.

With reference again to **Figure 4**, once device 20 is attached, balloon 48 is filled with an inflation fluid 52 or gel material as described below. The buttressing layer 46 buttresses the structure so that the inflation of balloon 48 preferentially displaces the wall segment of the heart inward toward the centerline of the ventricular cavity (as indicated in **Figure 2**.) This result is obtained by designing the buttressing layer 46 to be stiffer than the compression layer 26, through either rigid material selection (*e.g.*, plastics, titanium, stainless) or using more pliable materials having greater widths depending upon their elastic modulus. This repositions the wall segment 22 and papillary muscle 34 toward their normal position, thereby releasing tension on the mitral leaflets 12, which can then meet or coapt more normally without regurgitation. A coapting leaflet surface sufficient to form an effective valve seal is illustrated. The processes of positioning, securing and monitoring displacement can be guided by imaging with ultrasound transducer 28, in order to minimize the amount of inflation fluid 52 or gel required to create the desired repair. Saline, blood or curable polymers are several options for the inflation material, however a large number of biocompatible materials will be understood by artisans to satisfy the inflatability requirements of the present invention.

With reference once again to **Figure 4**, balloon 48 may include a cannula or access port 54 such as the plastic tube illustrated as leading out of the buttressing layer 46 to a syringe attachment port 56. In another embodiment, a self-sealing silicone rubber port can be utilized, allowing penetration a filling needle that is later withdrawn. For long-term stability of inflatable reservoir size, the syringe port 56 should be locked, or the plastic tube heat-annealed and closed. Other methods for sealing a port are known in the art. In a further embodiment, the cannula or access port 54 is elongated and connected to a sterile

subcutaneous port implanted within the chest wall beneath the skin, allowing for subsequent adjustment of inflation material in the reservoir as necessary to maintain valve competence.

The present invention further provides an embodiment (not shown) in which the mechanism for displacing the compression member **26** involves incrementally filling a fill region disposed, again, between a compression member and a buttressing portion with solid or gel material at the time of implantation, and perhaps intermittently thereafter, to achieve the desired reduction of AVR. This may be accomplished by instilling sterile gel into the fill region, using larger ports for the more viscous material, or by stuffing the fill region with layers of expanded PTFE, Dacron™, curable polymers, or other fillers shaped from silicone or other materials. Such fillers may be added between the compression member and buttressing portion, or simply between the buttressing portion (*e.g.*, a patch) and the heart muscle until the desired reduction in regurgitation has been achieved. This may be particularly effective for long-term maintenance.

Advantages of the embodiments of the present invention described above are that they provide direct, targeted repositioning of the positioning of the papillary muscles in a manner completely external to the heart and hence do not require cardiopulmonary bypass or stopping the heart. Unlike other approaches, the present invention can be applied as a surgical option, but does not require excision of myocardium, and thereby the integrity of the muscle layers may be preserved. Devices in accordance with the present invention also allow immediate and/or intermittent adjustment of the papillary muscle repositioning by incrementally varying the displacement of the compression element, through inflation and/or deflation of the inflatable reservoir, or through other filling methods.

In the embodiment illustrated in **Figure 4**, the present invention also provides embodiments wherein the displacement of the compression member **26**, and thus the segment **22** of the heart muscle wall, is active. Device **20** is made to expand and contract in temporal coordination with the electrical activation of the chambers of the heart, thereby providing the additional benefits of replacing a damaged, non-contracting wall with an active device to augment heart pumping.

One active displacement method involves connecting the inflatable reservoir (*e.g.*, balloon 48) through a plastic tube 58 to an electrically driven pump 60 placed on the surface of the heart or anchored elsewhere within the chest cavity or along the diaphragm or rib surfaces. In simplest form, an electromechanical motor 62 drives a piston 64 to pump inflation fluid 52 from a supply reservoir 66 into the balloon 48, and withdraws the fluid as the heart relaxes. The inflation fluid is preferably relatively non-viscous for efficient pump operation. Pump 60 is triggered by electrical signals recorded by a wire 68, anchored by a tined attachment 70 to the heart wall 72 adjacent the device 20 and amplified for pump triggering. Alternatively, pump 60 can be triggered by a standard transvenous cardiac pacemaker, which senses the cardiac electrical signal and outputs an amplified signal to the pump. Electrical energy for pump operation can be stored in a subcutaneous battery that is re-charged noninvasively using radiofrequency power transmitted through the skin. The tube 58 connecting pump 60 to the inflation reservoir is of larger bore and therefore lower resistance than the smaller access port 54 used to fill the balloon in the static (non-expanding) embodiment.

With reference to **Figure 6A**, active displacement may alternatively be achieved by use of strips 74 of genetically bioengineered replacement muscle or artificial muscle (cardiomyocyte) in addition to or in lieu of a patch or pouch 24. If the infarct involves and displaces the papillary muscles, an external patch including such artificial muscles will provide the benefit of re-shaping the infarcted wall to relieve AVR, as well as increasing contraction and relaxation to improve overall cardiac function.

Such artificial muscle is made of conducting polymers (such as polypyrrole or polythiophene), repeating pyrrole units that are electrically triggered to contract, for example, over an infarcted region in temporal coordination with the cardiac cycle. **Figures 6B through 6E** illustrate several artificial muscle embodiments comprised of crosslinked and parallel polymer configurations. The conducting polymer strips can change size and shape as current is passed through them, and therefore have the capacity to expand, contract, and generate force. Recent advances have led to swelling pyrrole-based polymers that can achieve tensions of 40 Meganewtons/meter² (over 250 x that of heart muscle), and accordion-like thiophene-based polymers with up to 23% changes in length (comparable to

myocardial fiber strain). For a further description of such artificial muscle, see Madden JD, Cush RA, Kanigan TS, Hunter IW. Fast contracting polypyrrole actuators. *Synthetic Metals* 2000;113:185-92; Madden JD, Madden PG, Hunter IW. Characterization of polypyrrole actuators: Modeling and performance. *Proceedings of SPIE 8th Annual Symposium on Smart Structures and Materials: Electroactive polymer activators and devices*. Yoseph Bar-Cohen, ed., SPIE Press 2001; Madden J. Conducting polymer actuators, Doctoral Dissertation, Massachusetts Institute of Technology 2000; Marsella MJ, Reid RJ. Toward molecular muscles: Design and synthesis of an electrically conducting poly{cyclooctatetrathiophene}. *Macromolecules* 1999;32:5982-84; Ding J, Price WE, Ralph SF, Wallace GG. Synthesis and properties of a mechanically strong poly(bithiophene) composite polymer containing a polyelectrolyte dopant. *Synthetic Metals* 2000;110(2):123-132; and Baughman RH. Conducting polymer artificial muscles. *Synthetic Metals* 1996;78:339-353, which are incorporated herein by reference.

With reference to **Figures 7A** and **7B**, ultrasound imaging can assist in recognizing when a mitral annulus **76** is considerably dilated, as indicated in **Figure 7A**. In this instance, extension of compression member **26** of device **20** (shown as a pouch) toward the annulus **76** of the valve can reduce annular size as well. Care must be taken to avoid direct pressure on the coronary vessels (such as the coronary sinus **78**) in the groove **80** of the heart between left ventricle **8** and left atrium **16**. This extension of compressive force towards the base of the heart effectively provides an external annuloplasty or annular size reduction that remedies both ends of the tethering imposed on the mitral leaflets **12** (annular and ventricular). Alternatively, use of the device **20** can be combined with other recently developed approaches for percutaneous annular size reduction. Addition of the pouch can be expected to enhance the efficacy of those other devices. **Figure 7B** illustrates a successful reduction in mitral annulus dilatation.

With reference to **Figures 8A** and **8B**, the present invention also provides an approach to reversing cardiac remodeling. This embodiment allows application not only to patients with localized heart damage and displacement of an individual papillary muscle (there are two **34'**, **34''**), but also to patients with global dilatation and dysfunction of the left ventricle caused by coronary artery disease or intrinsic disease of the muscle cells

(cardiomyopathies causing heart failure.) As shown in **Figure 8A**, in such circumstances the heart **2** becomes more spherical than the normal bullet shape, displacing both papillary muscles **34'**, **34''** away from the center of the cavity **82** so that the mitral leaflets **84** are stretched and cannot close, producing regurgitation. (Note that the view shown is a side-to-side ultrasound view through the two papillary muscles **34'**, **34''**.) In this embodiment, therefore, devices **20** (e.g., pouches) are placed over both papillary muscles and inflated to reposition those muscles closer to the center of the cavity **82** and to the mitral annulus **86**, thereby relieving tension on the leaflets **84** and reducing regurgitation (as reflected in **Figure 8B**.) An external view of this embodiment is illustrated in **Figure 8C** in the anatomic orientation of the heart (apex down), with two separate pouch devices **20** on the posterior aspect of the heart **2** to displace both of the two papillary muscles.

Figure 8D illustrates an embodiment of device **20** wherein two compressive surfaces, shown as balloons **88**, are attached and buttressed by a buttressing layer, shown as a patch or pouch **24**. The patch or pouch **24** is sutured to the heart **2** both along its edges and at points **90** encircling the balloons **88**. These encircling suture points **90** limit side-to-side expansion of the balloons so that they have the desired effect on the papillary muscles. These embodiments for global dysfunction may also be modified to employ any of the treatment methods described above (i.e., active displacement, extension of compression to the annulus, etc.), alone or in combination.

Any of the device embodiments described herein may be employed in a minimally invasive fashion using thoracoscopy or robotic surgery. In such processes, elongated or tubular viewing and manipulating devices are inserted into the thoracic cavity through one or more small openings in the chest wall. Exemplary devices include videoscopic devices, instruments for pericardial incision and for securing the device to the external heart surface. In these embodiments, the device itself is reversibly collapsible or furlable to allow such introduction, and may be made self-expanding using a variety of mechanisms recognized in the art, such as mounting rings comprised of shape memory materials. This self-expanding technology is known to artisans. Numerous additional embodiments of the device involving variations in the shape, size, and materials of the pouch or patch devices will be readily appreciated by said artisans. For example, rectangular devices may be used, and a

range of sizes can be available and selected by the physician to match the size of the damaged or bulging area of heart muscle as displayed by ultrasound or magnetic resonance imaging.

With reference to **Figures 9A** through **9D**, in another embodiment, the present invention provides structures, such as springs or hoops, made of shape memory materials, such as super elastic nickel titanium alloy (Nitinol™ www.nitinol.com) may be used to maintain papillary muscle displacement or deformity and to reverse cardiac remodeling. **Figures 9A** and **9B** illustrate two versions of such deforming device **92**. Device **92** comprises pre-formed or adjustable structures that are affixed to an external surface of the heart so as to reposition the papillary muscle and normalize mitral leaflet coaptation. Device **92** may comprise a mounting ring **94** lying on the heart surface and elements or structures extending below the level of the mounting ring as a continuous or interrupted surface, such as a meshwork or radial spokes. Affixing the ring **94** to the external heart surface **22** forces the protruding elements to displace the papillary muscle, directing it toward the center line of the ventricular cavity (as described above.) The device may also be shaped to direct the papillary muscle **34** toward the base of the heart (the mitral annulus **18**) to reduce the tethering applied to the mitral leaflets. Such indenting or repositioning devices may be comprised of fixed or shape memory materials such as nickel titanium alloy. Devices of different size and shape may be available to provide different degrees of repositioning, which can be estimated through echocardiographic imaging as the device or a surgeon's finger is placed to exert pressure against the heart wall.

With reference to **Figures 10A** and **10B**, the present invention further provides a method and apparatus for reducing AVR involving delivery of an internal stiffener **94** serving as a buttress into a muscle wall **96**. A damaged heart wall typically becomes thinner by virtue of the loss of contracting muscle cells, and bulges outward under the influence of pressure within the ventricular cavity **9**. In this embodiment, the internal stiffener **94** comprised of biologically compatible material is delivered (*e.g.*, by syringe **98** injection or implantation) into a region of the damaged heart wall **96**, through the exposed external heart wall or by a catheter **100** passing through the aortic valve **102** and guided by electrical sensing or ultrasound imaging to locate the damaged wall. **Figure 10B** shows the

resulting internal stiffener **94** or buttress to thicken the affected wall **96** and alter its material properties so that its deformation is reduced. This results in reduced mitral leaflet **12** tethering and regurgitation in parallel. This embodiment can be applied both in localized damage involving one papillary muscle and in global dysfunction affecting both muscles.

5 The material injected may include but is not limited to collagen matrix or myoblasts (primitive muscle cells, harvested, for example, from the patient's own skeletal muscle), which have been shown to remain viable even in heart walls with limited blood supply, and may develop contractile capabilities as well.

Such stiffeners may be delivered within a structure, such as a pouch **104** or cellular scaffold, inside the heart wall. The initial structure may be biodegradable, such that the stiffener material has time to stiffen before the structure degrades.

One skilled in the art will also recognize that the techniques and devices described above have the additional advantage of limiting or even reversing the phenomenon of ventricular remodeling. Remodeling is a progressive expansion of a damaged heart affecting both damaged and undamaged walls (for example, walls with and without sufficient blood supply), associated with weakened contraction of the initially undamaged walls. Mitral regurgitation provides a potent stimulus for such remodeling, and reducing such regurgitation using the device of the invention can therefore also limit remodeling. Further, Kelley ST, et al. (Circulation 1999;99:135-42) have shown that even limiting the expansion of a damaged wall not located near the papillary muscles (and therefore not causing regurgitation) has the added benefit of limiting remodeling and maintaining contractile function of the entire heart. The present invention therefore provides this additional benefit.

Experience of the inventors with the embodiment of the device in **Figure 4** (with or without inner pouch layer) in 10 animals with acute or chronic ischemic mitral regurgitation has shown that the regurgitation could be reversed and eliminated in all instances without adverse effects on left ventricular pump or filling function or pressures. We studied 10 sheep with ischemic MR produced by circumflex ligation with inferior infarction, six acutely and four at 8 weeks post-MI. A Dacron™ pouch containing an inflatable balloon was placed over the papillary muscles and adjusted under echo guidance

with the aim of reversing left ventricle remodeling to reposition the infarcted papillary muscle toward the anterior mitral annulus, thereby reducing leaflet tethering and mitral valve regurgitation. 3D echo assessed mitral valve geometric changes, including tethering distance from papillary muscle to anterior annulus. In 7 sheep, sonomicrometry and left ventricular Millar catheters were placed to assess changes in end-systolic and end-diastolic pressure volume relationships (ESPVR and EDPVR), and microspheres injected to assess coronary flow. In all 10 sheep, moderate MR post-MI resolved with pouch application alone (n=3) or echo-guided balloon inflation, which repositioned the infarcted PM toward normal, decreasing the papillary muscle tethering distance from 31.1 ± 2.5 mm post-MI to 26.8 ± 1.8 with pouch ($p < 0.01$ baseline = 25.5 ± 1.5). left ventricular contractility was unchanged (ESPVR slope (3.4 ± 1.6 mm Hg/ml with pouch vs 2.8 ± 1.6 post-MI.) Although left ventricular stiffness constant trended higher (0.07 ± 0.05 ml⁻¹ vs 0.05 ± 0.03 post-MI, $p = 0.06$), LVDEP was unchanged as mitral valve regurgitation resolved. Coronary flow to non infarcted regions was not significantly reduced.

15 An additional 5 animals with chronic ischemic mitral valve regurgitation were followed for 6 to 8 weeks after successful reduction of mitral regurgitation without recurrent leak.

In another embodiment shown in **Figure 11**, the present invention provides an apparatus and technique for anteriorly displacing (in the direction indicated by arrows **106**) the annulus (dashed lines and **18**) using the injectable, space-occupying material **108** injected (*e.g.*, by catheter system **110** through a needle **112**) or otherwise inserted through a needle **112** into the tissue plane **114** between the coronary sinus **116** and annulus resulting in anterior displacement of the annulus. Because the coronary sinus **116** is the largest vein of the heart muscle, it is ideally suited for deployment of devices to affect or displace the mitral annulus as it is located immediately adjacent to the mitral annulus and is readily accessible by percutaneous catheter systems **110**. Particular advantages to deployment of device through the coronary sinus is the ease of percutaneous access to the coronary sinus which would entail a catheter threaded into the right side of the heart via a peripheral leg or arm vein. This would obviate the need for an open-surgical procedure for delivery of device if material.

Figure 12 is an expanded view of the region of the heart proximate to the injection site(s). Orthogonal injection needle orientations **118,120** indicate the ability to inject material **108** wherever necessary to effect the desired displacement. This could be directed into the
5 tissue plane between the annulus and coronary sinus or more inferiorly into the base of the heart. The biocompatible material is preferably comprised of a polymer gel or similar material.

As shown in **Figure 11**, the resulting displacement of the mitral annulus (dashed lines and **18**) anteriorly reduces the overall mitral annular area, restoring mitral leaflet
10 coaptation. Characteristics of the material **108** include flexibility of deformation and physical properties of the material are chosen to withstand the forces normally generated in contracting myocardium such that it would retain its original shape and volume. The material **108** is preferably initially in liquid form and hardens at body temperature and hence injectable through commercially available percutaneous catheter systems such as
15 Transvascular, Inc. (Menlo Park, CA) or BioCardia, Inc. (South San Francisco, CA). Hydrogels such as alginate polymers are an example of such material. These polymers are biocompatible and biodegradable and can be adapted to be in liquid form at room temperature but solidify at body temperature (for more on these polymers, see Vacanti JP, Langer R. Tissue engineering: the design and fabrication of living replacement devices for
20 surgical reconstruction and transplantation. *Lancet*.1999 Jul;354 Suppl 1:SI32-4, and Marler JJ, Guha A, rowley J, Koka R, Mooney D, Upton J, Vacanti JP. Soft tissue augmentation with injectable alginate and syngeneic fibroblasts. *Plastic Reconstructive Surgery* 2000; May;105(6):2049-58, incorporated herein by reference.) In addition, the firmness of the hydrogel can be adjusted to the degree necessary to withstand the normal
25 loading forces present in the heart.

With reference to **Figure 13**, a catheter **120** with an injection needle **122** is placed into the coronary sinus **124** and aliquot injections **132** of the biomaterial **108** are made, as necessary, into the tissue plane **126** between the coronary sinus **124** and mitral annulus **128** along the length of the mitral annulus through the needle **122**. The injections produce

anterior or inward displacement of the posterior mitral leaflet **34'** towards anterior mitral leaflet **34''**, restoring proper mitral leaflet coaptation (closure of mitral orifice **130**).

In another embodiment illustrated in **Figure 14**, material **108** is injected within an encapsulating structure **134** or shell, such as a polymeric balloon or a cellular matrix
5 composed of fibroblasts, which would serve to retain the volume and shape of the injected material. Balloon material could be similar to those in artificial urinary sphincters which contain implantable and inflatable balloons or balloon expanders used in plastic reconstructive surgery (for further discussion of these materials, see Wilson TS, Lemack GE, Zimmern PE. Management of intrinsic sphincteric deficiency in women. J Urol. 2003
10 May;169(5):1662-9; Gonzalez R, Schimke CM. Strategies in urological reconstruction in myelomeningocele. Curr Opin Urol. 2002 Nov;12(6):485-90; Kabaker SS, Kridel RW, Krugman ME, Swenson RW. Tissue expansion in the treatment of alopecia. Arch Otolaryngol Head Neck Surg. 1986 Jul;112(7):720-5. Radovan C. Tissue expansion in soft tissue reconstruction. Plast Reconstr Surg 1984 Oct;74(4):482-92; incorporated herein by
15 reference.) In another embodiment, biomaterial could be injected within a fibroblast shell, allowing for retention of volume and shape of injected material.

With reference to **Figure 15**, the material **108** can also be injected through a catheter **136** in the coronary sinus **124** inferiorly into the base of the heart (as indicated by needle orientation **118** in **Figure 12**), along the length of the mitral annulus **18**, resulting in
20 an appropriate displacement of the mitral leaflet **12**. Injections into the base of the heart could serve as an adjunct to injections at the annular level or as an independent method to displace the annulus.

In another embodiment, material **108** consists of tissue-engineered material, with an initial scaffolding network. The tissue-engineered material could be adapted or customized
25 to the appropriate physical properties to effect mitral annular displacement. Specifically, tissue-engineered material would consist of patient's own stem cells and programmed to transform into chondrocytes, producing a cartilaginous structure in the desired region (see Yoshimoto H, Shin YM, Terai H, Vacanti JP. A biodegradable nanofiber scaffold by electrospinning and its potential for bone tissue engineering. Biomaterials. 2003
30 May;24(12):2077-82; Abukawa H, Terai H, Hannouche D, Vacanti JP, Kaban LB, Troulis

MJ. Formation of a mandibular condyle in vitro by tissue engineering. J Oral Maxillofac Surg. 2003 Jan;61(1):94-100; Fuchs JR, Terada S, Hannouche D, Ochoa ER, Vacanti JP, Fauza DO. Engineered fetal cartilage: structural and functional analysis in vitro. J Pediatr Surg. 2002 Dec;37(12):1720-5; Young CS, Terada S, Vacanti JP, Honda M, Bartlett JD, 5 Yelick PC. Tissue engineering of complex tooth structures on biodegradable polymer scaffolds. J Dent Res. 2002 Oct;81(10):695-700; incorporated herein by reference.) Cartilaginous material would have the desired physical firmness to result in anterior displacement of the annulus as well as ability to withstand the forces present in the heart. Cartilaginous structures are present naturally in the anterior portion of the mitral annulus. 10 Other tissue-engineered material could consist of injection of muscle into the annulus or base of the heart to produce annular displacement (see Saxena AK, Willital GH, Vacanti JP. Vascularized three-dimensional skeletal muscle tissue-engineering. Biomed Mater Eng. 2001;11(4):275-81; Saxena AK, Marler J, Benvenuto M, Willital GH, Vacanti JP. Skeletal muscle tissue engineering using isolated myoblasts on synthetic biodegradable polymers: 15 preliminary studies. Tissue Eng. 1999 Dec;5(6):525-32; incorporated herein by reference.) An additional advantage of muscle would be the potential to produce dynamic contraction, timed to the cardiac cycle to augment heart function.

Proper localization of the injection(s) may be aided by echocardiography. Additionally, the efficacy of the appropriate posterior mitral annular correction can 20 optionally be monitored and guided noninvasively by real-time echocardiography.

While the foregoing specification has been described with regard to certain preferred embodiments, and many details have been set forth for the purpose of illustration, it will be apparent to those skilled in the art, that without departing from the spirit and scope of the invention, the invention may be subject to various modifications 25 and additional embodiments, and that certain of the details described herein can be varied considerably without departing from the basic principles of the invention. Such modifications and additional embodiments are also intended to fall within the scope and spirit of the invention appended claims.

30 What is claimed is:

At the beginning of each of the following claims, in parentheses, are initials of the individuals believed to be the co-inventors of the subject matter of that particular claim, wherein "RL" refers to Robert A. Levine, "JH" refers to Judy Wei Ming Hung, "LG" refers to J. Luis Guerrero, and "GV" refers to Gus Vlahakes.

5

1. (RL, JH, LG) A method for reducing regurgitation of an atrioventricular valve of a heart, comprising the steps of:
 - securing an apparatus to an exterior wall segment of a heart, said apparatus having a compression member in contact with said exterior wall segment of the heart; and
 - displacing said compression member, thereby moving said exterior wall segment inward and toward the center line of the ventricular cavity of the heart so as to normalize papillary muscle geometry and improve leaflet coaptation.

2. (RL, JH, LG) The method of claim 1, wherein the displacing step further comprises the step of:
 - inflating the apparatus, wherein the apparatus further includes an inflatable reservoir disposed between the compression member and a buttressing portion.

3. (RL, JH, LG) The method of claim 2, wherein the displacing step further comprises the step of:
 - deflating the apparatus.

4. (RL, JH, LG) The method of claim 3, wherein the displacing step further comprises the step of:
 - temporally coordinating the inflating and deflating steps with electrical activation of the heart.

5. (RL, JH, LG) The method of claim 3, wherein the displacing step further comprises the step of:
 - pumping an inflation fluid between said inflatable reservoir and a supply reservoir.

6. (RL, JH, LG) The method of claim 3, wherein the displacing step further comprises the step of:

pumping an inflation gel between said inflatable reservoir and a supply reservoir.

7. (RL, JH, LG) The method of claim 1, wherein the displacing step further comprises the step of:

adjustably and intermittently inflating and deflating the apparatus over an extended period of time, wherein the apparatus further includes an inflatable reservoir disposed between the compression member and a buttressing portion.

8. (RL, JH, LG) The method of claim 1, wherein the securing step further comprises the step of:

suturing said apparatus to the exterior wall of the heart beneath a top layer of the pericardium surrounding the heart.

9. (RL, JH, LG) The method of claim 1, wherein the securing step further comprises the step of:

suturing said apparatus to the exterior wall of the heart, attached to the pericardium surrounding the heart..

10. (RL, JH, LG) The method of claim 1, wherein the securing step further comprises the step of:

guiding the placement of the apparatus with echocardiographic imaging.

11. (RL, JH, LG) The method of claim 1, wherein the displacing step further comprises the step

of:

guiding the displacement of said compression member based upon leaflet coaptation as observed by echocardiographic imaging.

12. (RL, JH, LG) The method of claim 1, further comprising the step of:

constructing said apparatus to have a contour based upon data collected through echocardiographic imaging.

13. (RL, JH, LG) The method of claim 1, wherein the displacing step further comprises the step

of:

filling said apparatus with a stuffing material, wherein said apparatus further includes a fillable region disposed between the compression member and a buttressing portion.

14. (RL, JH, LG) The method of claim 13, wherein the stuffing material includes engineered

tissue.

15. (RL, JH, LG) The method of claim 14, wherein the engineered tissue provides a stiffening force in the fillable region.

16. (RL, JH, LG) The method of claim 13, wherein the displacing step further comprises:

electrically triggering the engineered tissue to contract in temporal coordination with electrical activation of the heart, said engineered tissue including artificial muscle composed of conducting polymers.

17. (RL, JH, LG) The method of claim 13, wherein:

at least one portion of the apparatus is biodegradable; and
the engineered tissue serves to move said exterior wall segment inward and toward the center line of the ventricular cavity of the heart so as to normalize papillary muscle geometry and improve leaflet coaptation.

18. (RL, JH, LG) The method of claim 13, wherein said fillable region includes a scaffold structure for receiving said stuffing material.

19. (RL, JH, LG) The method of claim 1, wherein the exterior wall segment comprises a deformed section of the exterior wall.
20. (RL, JH, LG) The method of claim 1, wherein the securing step comprises an invasive cardiac procedure.
21. (RL, JH, LG) The method of claim 1, wherein the securing step comprises a minimally invasive or thoracoscopic procedure introducing viewing and operating instruments and devices through one or more small openings and elongated tubular structures inserted through the chest wall.
22. (RL, JH, LG) The method of claim 1, further comprising the steps of:
 furling the apparatus;
 delivering the apparatus to a location proximate the exterior wall segment;
and
 unfurling the apparatus at said location.
23. (RL, JH, LG) The method of claim 1, further comprising the step of:
 repeating the securing and displacing steps at a different exterior wall segment of the heart.
24. (RL, JH, LG) The method of claim 23, wherein said different exterior wall segment is on the other side of the heart.
25. (RL, JH, LG) The method of claim 1, wherein the displacing step serves to reduce mitral annulus size.

26. (RL, JH, LG) An apparatus for reducing regurgitation of an atrioventricular valve of a heart,

comprising:

a compression member adapted to contact an exterior wall segment of a heart;

a displacement mechanism for moving said compression member inward and toward the center line of the ventricular cavity of the heart so as to normalize papillary muscle geometry and thereby improve leaflet coaptation; and

means for securing the compression member to the exterior wall of the heart.

27. (RL, JH, LG) The apparatus of claim 26, wherein the displacement mechanism comprises:

a buttressing portion; and

an inflatable reservoir disposed between said buttressing portion and said compression member such that inflation of the inflatable reservoir with an inflation material moves said compression member inward and toward the center line of the ventricular cavity of the heart.

28. (RL, JH, LG) The apparatus of claim 27, wherein the buttressing portion comprises a patch.

29. (RL, JH, LG) The apparatus of claim 28, further comprising a suturable ring encircling said

patch.

30. (RL, JH, LG) The apparatus of claim 27, further comprising:

another inflatable reservoir disposed between said buttressing portion and another compression member such that inflation of the another inflatable reservoir

with an inflation material moves the another compression member inward and toward the center line of the ventricular cavity of the heart.

31. (RL, JH, LG) The apparatus of claim 27, wherein the buttressing portion resists outward expansion of the inflatable reservoir.
32. (RL, JH, LG) The apparatus of claim 27, wherein the inflatable reservoir includes an access port through which the reservoir is inflatable.
33. (RL, JH, LG) The apparatus of claim 32, wherein said access port is implanted within the chest wall beneath the skin.
34. (RL, JH, LG) The apparatus of claim 32, wherein said access port is implanted within the chest wall within a pouch beneath the skin.
35. (RL, JH, LG) The apparatus of claim 32, wherein the access port permits deflation of the reservoir.
36. (RL, JH, LG) The apparatus of claim 32, wherein the access port is composed in part of a self-sealing material.
37. (RL, JH, LG) The apparatus of claim 32, wherein the access port is lockable through heat treating.
38. (RL, JH, LG) The apparatus of claim 27, further comprising:

an inflation material supply; and
a pump in communication with said reservoir and said inflation material supply, wherein said pump operates to inflate and deflate said reservoir.

39. (RL, JH,LG) The apparatus of claim 38, wherein said pump operates in temporal coordination with electrical activation of the heart.

40. (RL, JH,LG) The apparatus of claim 38, wherein said pump operates in response to an electrical trigger.

41. (RL, JH,LG) The apparatus of claim 38, wherein said pump is secured in the vicinity of the
chest wall or abdomen.

42. (RL, JH,LG) The apparatus of claim 27, wherein said inflation material comprises a fluid.

43. (RL, JH,LG) The apparatus of claim 27, wherein said inflation material comprises a gel.

44. (RL, JH,LG) The apparatus of claim 26, wherein the compression member has a contour design related to the contour of the exterior wall segment.

45. (RL, JH,LG) The apparatus of claim 26, wherein the displacement mechanism comprises:

a buttressing portion; and
a fillable region disposed between said buttressing portion and said compression member such that filling of the fillable region with a stuffing material moves said compression member inward and towards the center line of the ventricular cavity of the heart.

46. (RL, JH, LG) The apparatus of claim 45, wherein the stuffing material includes engineered cells.
47. (RL, JH, LG) The apparatus of claim 46, wherein the engineered cells provide a stiffening force in the fillable region.
48. (RL, JH, LG) The apparatus of claim 45, wherein the stuffing material includes artificial muscle composed of conducting polymers that are electrically triggered to contract in temporal coordination with electrical activation of the heart.
49. (RL, JH, LG) The apparatus of claim 46, wherein:
at least a portion of the apparatus is biodegradable; and
the engineered cells serve to move said exterior wall segment inward and towards the center line of the ventricular cavity of the heart.
50. (RL, JH, LG) The apparatus of claim 45, wherein said fillable region contains a structure for receiving said stuffing material.
51. (RL, JH, LG) The apparatus of claim 26, wherein:
said compression member comprises a structure including engineered cells;
and
said displacement mechanism comprises a deforming force provided by said structure.
52. (RL, JH, LG) The apparatus of claim 26, wherein:
said compression member comprises a structure including conducting polymers;

and

said displacement mechanism comprises electrical triggers for said conducting polymers.

53. (RL, JH, LG) The apparatus of claim 45, wherein said stuffing material comprises a curable

polymer.

54. (RL, JH, LG) The apparatus of claim 26, wherein said apparatus is furlable.

55. (RL, JH, LG) A method for reducing regurgitation of an atrioventricular valve of a heart, comprising the steps of:

securing an apparatus to an exterior wall segment of a heart, said apparatus having an indented compression member in contact with said exterior wall segment of the heart, so as to move said exterior wall segment inward and toward the center line of the ventricular cavity of the heart so as to normalize papillary muscle geometry and improve leaflet coaptation.

56. (RL, JH, LG) The method of claim 55, wherein the securing step serves to reduce mitral annulus size.

58. (RL, JH, LG) The method of claim 56, wherein the adjusting step further comprises the step

of:

guiding the displacement of said compression member based upon leaflet coaptation as observed by echocardiographic imaging.

59. (RL, JH, LG) The method of claim 55, wherein the securing step further comprises the step

of:

suturing said apparatus to the exterior wall segment of the heart beneath a top layer of the pericardium surrounding the heart.

60. (RL, JH, LG) The method of claim 55, wherein the securing step further comprises the step

of:

suturing said apparatus to the exterior wall of the heart, attached to the pericardium surrounding the heart.

61. (RL, JH, LG) The method of claim 55, wherein the securing step further comprises the step

of:

guiding the placement of the apparatus with echocardiographic imaging

62. (RL, JH, LG) The method of claim 55, further comprising the step of:

constructing said apparatus to have a contour based upon data collected through echocardiographic imaging

63. (RL, JH, LG) The method of claim 55, wherein the exterior wall segment comprises a deformed section of the exterior wall.

64. (RL, JH, LG) The method of claim 55, wherein the securing step comprises an invasive cardiac procedure.

65. (RL, JH, LG) The method of claim 55, wherein the securing step comprises a thoracoscopic procedure.

66. (RL, JH, LG) The method of claim 55, further comprising the steps of:

furling the apparatus;
delivering the apparatus to a location proximate the exterior wall segment;
and
unfurling the apparatus at said location.

67. (RL, JH, LG) The method of claim 55, further comprising the step of:

repeating the securing and displacing steps at a different exterior wall segment of the heart.

68. (RL, JH, LG) The method of claim 67, wherein said different exterior wall segment is on the

other side of the heart.

69. (RL, JH, LG) An apparatus for reducing regurgitation of an atrioventricular valve of a heart,

comprising:

an indented compression member adapted to contact an exterior wall segment of a heart so as to move said exterior wall segment inward and toward the center line of the ventricular cavity of the heart so as to normalize papillary muscle geometry and improve leaflet coaptation; and

means for securing the compression member to the exterior wall of the heart.

70. (RL, JH, LG) The apparatus of claim 69, further comprising means for adjusting said apparatus to change the degree of movement of said exterior wall segment.

71. (RL, JH, LG) The apparatus of claim 69, wherein the compression member has a contour related to the contour of said exterior wall segment.

72. (RL, JH, LG) The apparatus of claim 69, wherein the apparatus is furlable.

73. (RL, JH, LG) A method of reversing cardiac remodeling, comprising the steps of:

- securing an apparatus to an exterior wall segment of a heart, said apparatus including a compression member in contact with said exterior wall segment of the heart; and
- actively displacing said compression member so as to cyclically move said exterior wall segment inward and toward the center line of the ventricular cavity, thereby normalizing cardiac geometry.

74. (RL, JH, LG) The method of claim 73, wherein the actively displacing step further comprises the steps of:

- inflating the apparatus, wherein the apparatus further includes an inflatable reservoir disposed between the compression member and a buttressing portion; and
- deflating the apparatus.

75. (RL, JH, LG) The method of claim 74, wherein the actively displacing step further comprises the step of:

- temporally coordinating the inflating and deflating steps with electrical activation of the heart.

76. (RL, JH, LG) The method of claim 74, wherein the actively displacing step further comprises

- the step of:
 - pumping an inflation fluid between said inflatable reservoir and a supply reservoir.

77. (RL, JH, LG) The method of claim 74, wherein the actively displacing step further comprises

- the step of:

pumping an inflation gel between said inflatable reservoir and a supply reservoir.

78. (RL, JH, LG) The method of claim 73, wherein the securing step further comprises the step

of:

suturing said apparatus to the exterior wall of the heart beneath a top layer of the pericardium surrounding the heart.

79. (RL, JH, LG) The method of claim 73, wherein the securing step further comprises the step

of:

suturing said apparatus to the exterior wall of the heart, attached to the pericardium surrounding the heart..

80. (RL, JH, LG) The method of claim 73, wherein the securing step further comprises the step

of:

guiding the placement of the apparatus with echocardiographic imaging.

81. (RL, JH, LG) The method of claim 73, wherein the actively displacing step further comprises

the step of:

guiding the displacement of said compression member based upon leaflet coaptation as observed by echocardiographic imaging.

82. (RL, JH, LG) The method of claim 73, further comprising the step of:

constructing said apparatus to have a contour based upon data collected through echocardiographic imaging.

83. (RL, JH, LG) The method of claim 73, wherein the actively displacing step further comprises

the step of:

filling said apparatus with an engineered tissue including artificial muscle composed of conducting polymers, wherein said apparatus further includes a fillable region adjacent said exterior wall segment; and

electrically triggering said engineered tissue material to contract in temporal coordination with electrical activation of the heart.

84. . (RL, JH, LG) The method of claim 83, wherein at least one portion of the apparatus is biodegradable.

85. (RL, JH, LG) The method of claim 83, wherein said fillable region includes a scaffold structure for receiving said engineered tissue.

86. . (RL, JH, LG) The method of claim 73, wherein the exterior wall segment comprises a deformed section of the exterior wall.

87. . (RL, JH, LG) The method of claim 73, wherein the securing step comprises an invasive cardiac procedure.

88. (RL, JH, LG) The method of claim 73, wherein the securing step comprises a thoracoscopic procedure.

89. (RL, JH, LG) The method of claim 73, further comprising the steps of:
furling the apparatus;

delivering the apparatus to a location proximate the exterior wall segment;
and
unfurling the apparatus at said location.

90. (RL, JH,LG) The method of claim 73, further comprising the step of:
repeating the securing and actively displacing steps at a different exterior
wall segment of the heart.

91. (RL, JH,LG) The method of claim 90, wherein said different exterior wall segment is
on the
other side of the heart.

92. (RL, JH,LG) An apparatus for reversing cardiac remodeling, comprising:
a compression member adapted to contact an exterior wall segment of a
heart;
an active displacement mechanism for cyclically moving said compression
member inward and toward the center line of the ventricular cavity of the heart so
as to normalize cardiac geometry; and
means for securing the compression member to the exterior wall segment of
the heart.

93. (RL, JH,LG) The apparatus of claim 92, wherein the active displacement mechanism
comprises:
a buttressing portion;
an inflatable reservoir disposed between said buttressing portion and said
compression member such that inflation of the inflatable reservoir with an inflation
material moves said compression member inward and toward the center line of the
ventricular cavity of the heart;
an inflation material supply; and

a pump in communication with said reservoir and said inflation material supply, wherein said pump operates to inflate and deflate said reservoir.

94. (RL, JH, LG) The apparatus of claim 93, wherein the buttressing portion comprises a patch.

95. (RL, JH, LG) The apparatus of claim 93, wherein the buttressing portion resists outward expansion of the inflatable reservoir.

96. (RL, JH, LG) The apparatus of claim 94, wherein the inflatable reservoir includes an access port through which adjustments to the reservoir may be made.

97. (RL, JH, LG) The apparatus of claim 93, wherein said access port is securable within the chest wall beneath the skin.

98. (RL, JH, LG) The apparatus of claim 93, wherein said access port is securable within the chest wall within a pouch beneath the skin.

99. (RL, JH, LG) The apparatus of claim 93, wherein the access port is composed in part of a self-sealing material.

100. (RL, JH, LG) The apparatus of claim 93, wherein the access port is lockable through heat treating.

101. (RL, JH, LG) The apparatus of claim 93, wherein said pump operates in temporal coordination with electrical activation of the heart.

102. (RL, JH, LG) The apparatus of claim 93, wherein said pump is secured in the vicinity of the
chest wall or abdomen.
103. (RL, JH, LG) The apparatus of claim 93, wherein said inflation material comprises a fluid.
104. (RL, JH, LG) The apparatus of claim 93, wherein said inflation material comprises a gel.
105. (RL, JH, LG) The apparatus of claim 92, wherein the compression member has a contour design related to the contour of the exterior wall segment.
106. (RL, JH, LG) The apparatus of claim 92, wherein the active displacement mechanism comprises:
a buttressing portion;
a fillable region disposed between said buttressing portion and said compression member including artificial muscle composed of conducting polymers that are electrically triggerable to contract in temporal coordination with electrical activation of the heart.
107. (RL, JH, LG) The apparatus of claim 106, wherein at least a portion of the apparatus is
biodegradable.
108. (RL, JH, LG) The apparatus of claim 106, wherein said fillable region contains a structure for
receiving said conducting polymers.

109. (RL, JH, LG) The apparatus of claim 106, wherein said apparatus is furlable.
110. (RL, JH, LG) A method of reversing cardiac remodeling, comprising the steps of:
securing an apparatus to an external wall segment of a heart, said apparatus including a compression member in contact with said exterior wall segment of the heart, a buttressing portion, and a region between said compression member and said buttressing portion within which is disposed a stiffening material, such that said compression member is displaced so as to move said exterior wall segment inward and toward the center line of the ventricular cavity, thereby normalizing cardiac geometry.
111. (RL, JH, LG) The method of claim 110, wherein the securing step serves to reduce mitral
annulus size.
112. (RL, JH, LG) The method of claim 110, wherein the stiffening material comprises engineered cellular material.
113. (RL, JH, LG) The method of claim 112, wherein the cellular material converts to bone over
time.
114. (RL, JH, LG) The method of claim 112, wherein the cellular material converts to cartilage
over time.
115. (RL, JH, LG) The method of claim 112, wherein the cellular material is disposed upon a
scaffold structure.

116. (RL, JH, LG) The method of claim 112, wherein at least a portion of the apparatus is biodegradable, and the cellular material serves to move said exterior wall segment inward and toward the center line of the ventricular cavity, thereby normalizing cardiac geometry
117. (RL, JH, LG) The method of claim 110, wherein the securing step comprises an invasive cardiac procedure.
118. (RL, JH, LG) The method of claim 110, wherein the securing step comprises a thoracoscopic procedure.
119. (RL, JH, LG) The method of claim 110, further comprising the steps of:
furling the apparatus;
delivering the apparatus to a location proximate the exterior wall segment;
and
unfurling the apparatus at said location.
120. (RL, JH, LG) The method of claim 110, further comprising the step of:
repeating the securing step at a different exterior wall segment of the heart.
121. (RL, JH, LG) The method of claim 120, wherein said different exterior wall segment is on the other side of the heart.
122. (RL, JH, LG, GV) A method of reversing cardiac remodeling, comprising the step of:
delivering a material into a region of tissue of the heart so as to displace a portion of the region of tissue inward and toward the center line of the ventricular cavity, thereby normalizing cardiac geometry

123. (RL, JH, LG, GV) A method for reducing regurgitation of an atrioventricular valve of a heart,

comprising the steps of:

delivering a material into a muscle wall region of a heart proximate the papillary muscle, said material displacing a portion of said muscle wall region inward and toward the center line of the ventricular cavity of the heart so as to normalize papillary muscle geometry and improve leaflet coaptation.

124. (RL, JH, LG, GV) The method of claims 122 or 123, wherein the delivering step further comprises the step of injecting the material.

125. (RL, JH, LG) The method of claims 122 or 123, wherein the muscle wall region comprises the tissue plane between the coronary sinus and mitral annulus in the heart.

126. (RL, JH, LG) The method of claims 122 or 123, wherein the muscle wall region comprises a portion of the base of the heart.

127. (RL, JH, LG, GV) The method of claims 122 or 123, wherein the muscle wall region includes damaged tissue.

128. (RL, JH, LG, GV) The method of claims 122 or 123, wherein the delivering step further includes the step of:
imaging the muscle wall region with ultrasound.

129. (RL, JH, LG, GV) The method of claims 122 or 123, wherein the material retains a predetermined shape and volume after delivery.

130. (RL, JH, LG, GV) The method of claims 122 or 123, wherein the material comprises a nickel titanium alloy.
131. (RL, JH, LG, GV) The method of claims 122 or 123, wherein the material comprises a hydrogel that stiffens near body temperature.
132. (RL, JH, LG, GV) The method of claims 122 or 123, wherein the material is encapsulated in a structure.
133. (RL, JH, LG, GV) The method of claim 132, wherein the structure is a balloon.
134. (RL, JH, LG, GV) The method of claim 132, wherein the structure is a cellular matrix comprised of fibroblasts.
135. (RL, JH, LG, GV) The method of claims 122 or 123, wherein the material is engineered cellular tissue.
136. (RL, JH, LG, GV) The method of claim 135, wherein the cellular tissue is delivered with a biodegradable scaffolding network.
137. (RL, JH, LG, GV) The method of claim 135, wherein the cellular tissue comprises stem cells programmed to transform into a cartilaginous or bony structure.
138. (RL, JH, LG, GV) The method of claim 135, wherein the cellular tissue comprises myocytes producing dynamic contraction in temporal coordination with electrical activation of the heart.

139. (RL, JH, LG) The method of claims 122 or 123, wherein the material comprises conductive polymers, and the material displaces the portion of the muscle wall region by contracting in response to electrical triggering.
140. (RL, JH, LG, GV) The method of claims 122 or 123, wherein the delivering step comprises an
invasive cardiac procedure.
141. (RL, JH, LG, GV) The method of claims 122 or 123, wherein the delivering step comprises a
thoracoscopic procedure.
142. (RL, JH, LG) The method of claims 122 or 123, wherein the delivering step serves to reduce
mitral annulus size.
143. (RL, JH, LG, GV) The method of claims 122 or 123, further comprising the step of:
repeating the delivering step at a different muscle wall region of the heart.

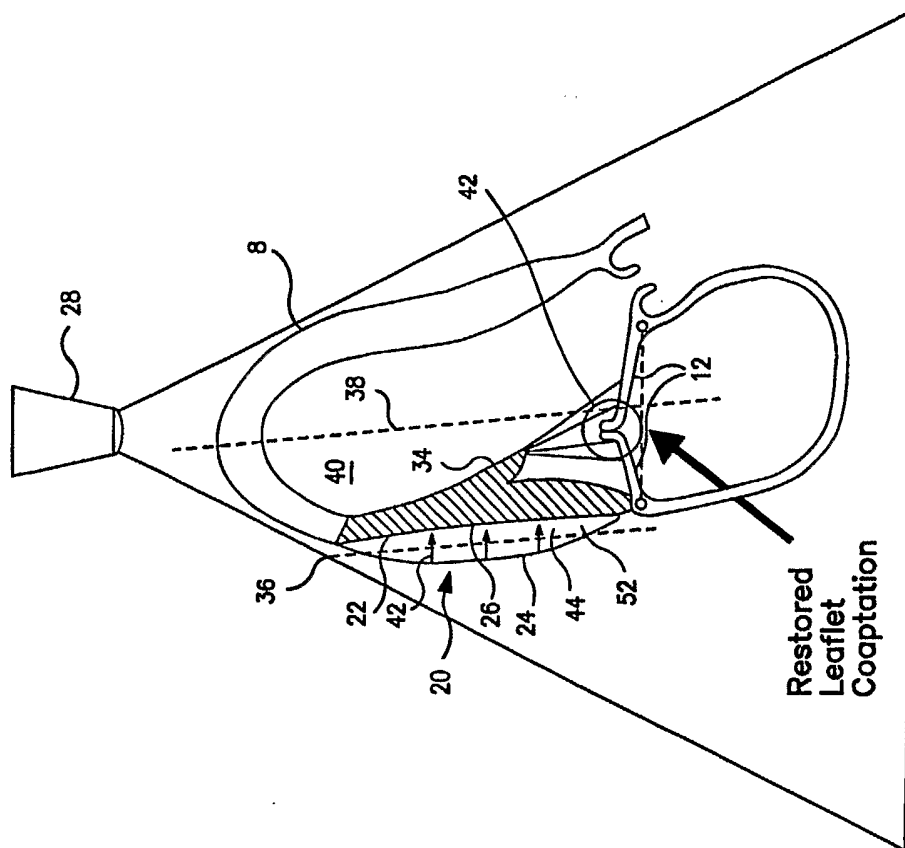

FIG. 2

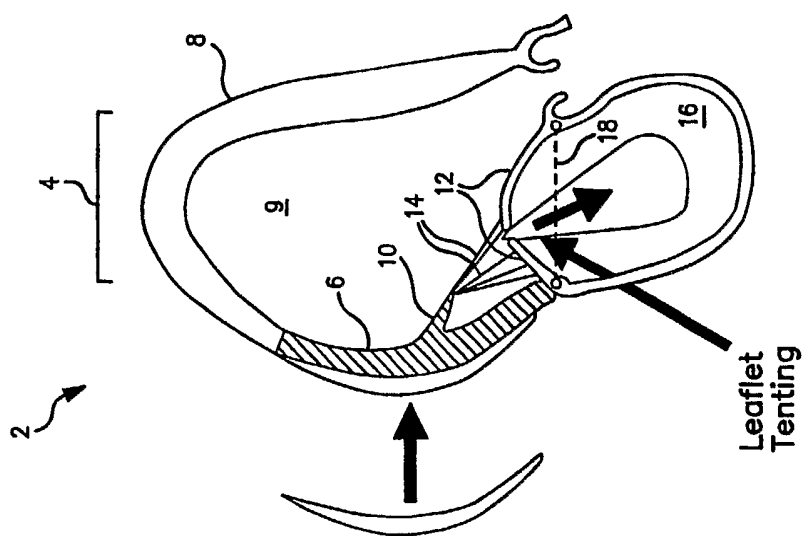

FIG. 1

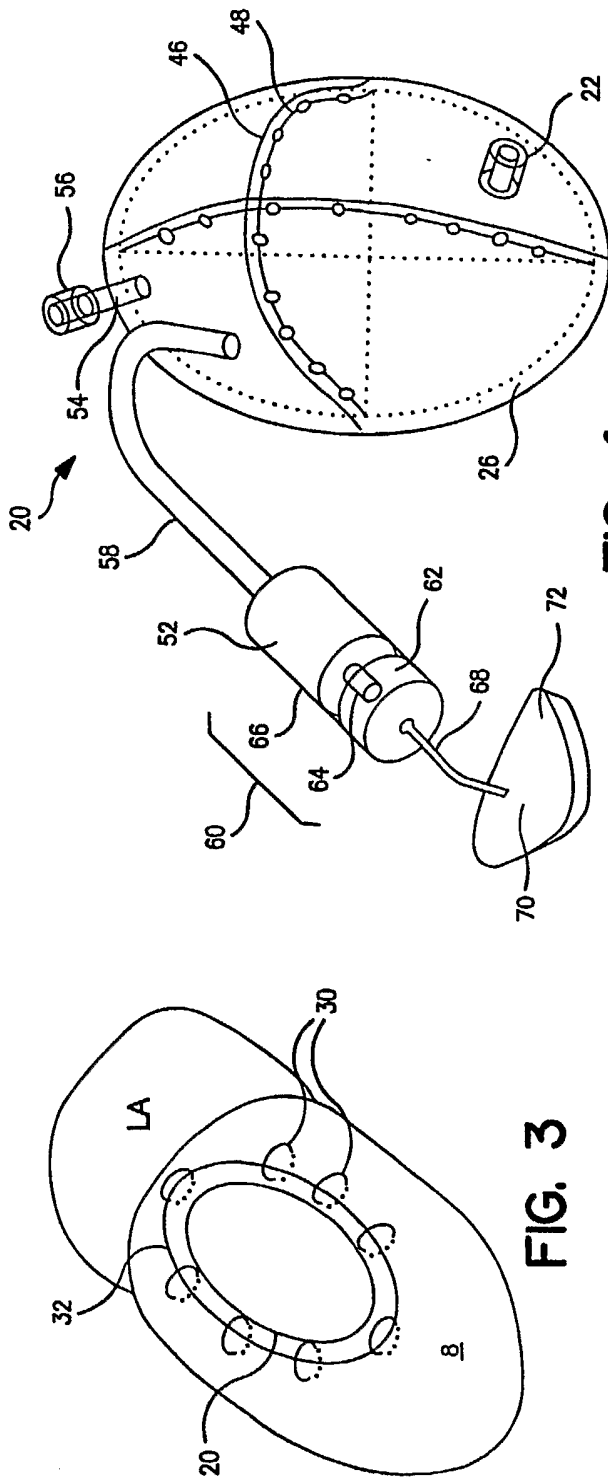

FIG. 4

FIG. 3

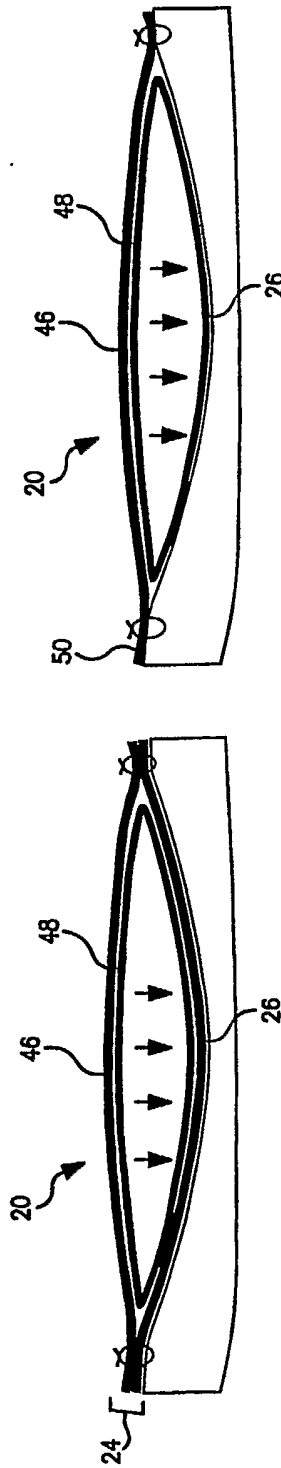

FIG. 5A

FIG. 5B

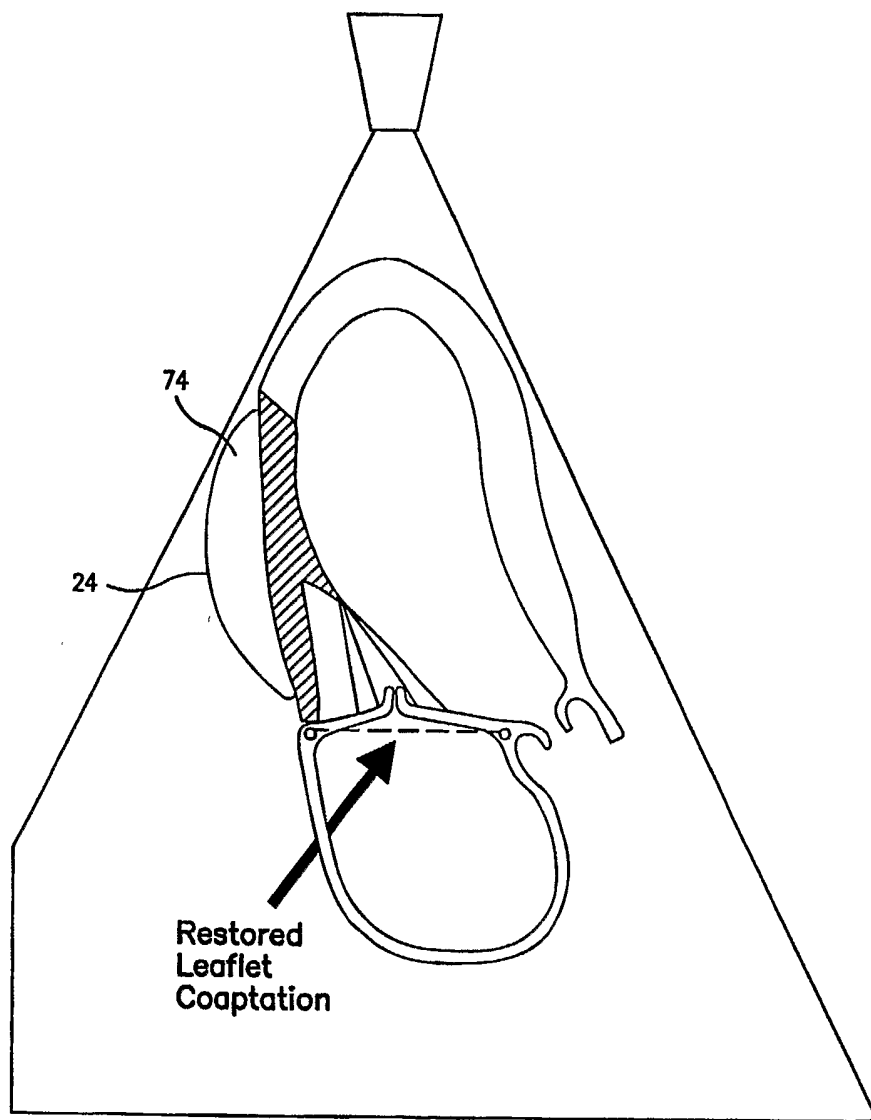
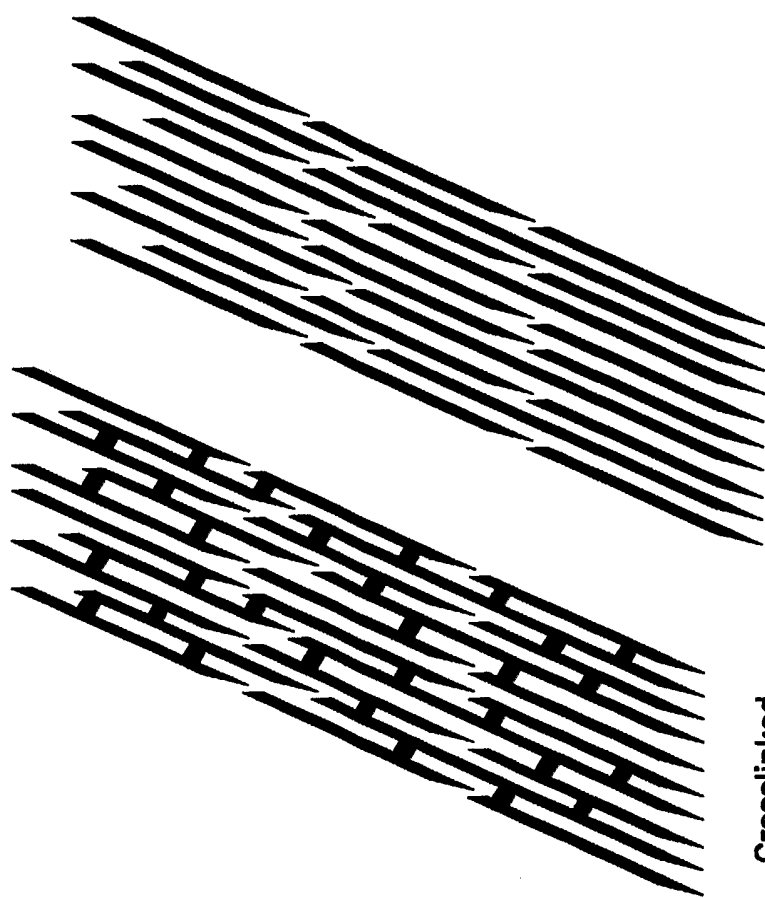
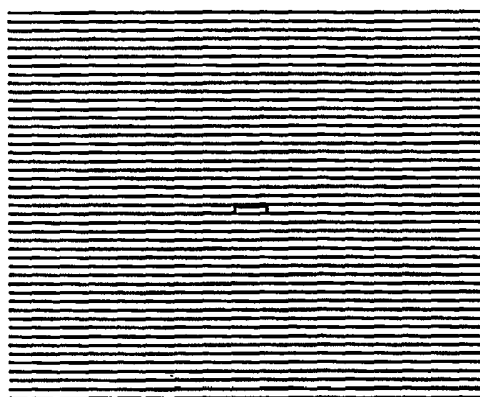

FIG. 6A



Crosslinked
Polymers
FIG. 6B

Parallel
Polymers
FIG. 6C



Parallel
Polymers
FIG. 6E

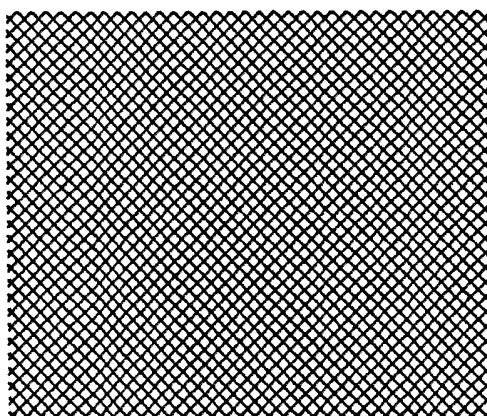

Crosslinked
Polymers
FIG. 6D

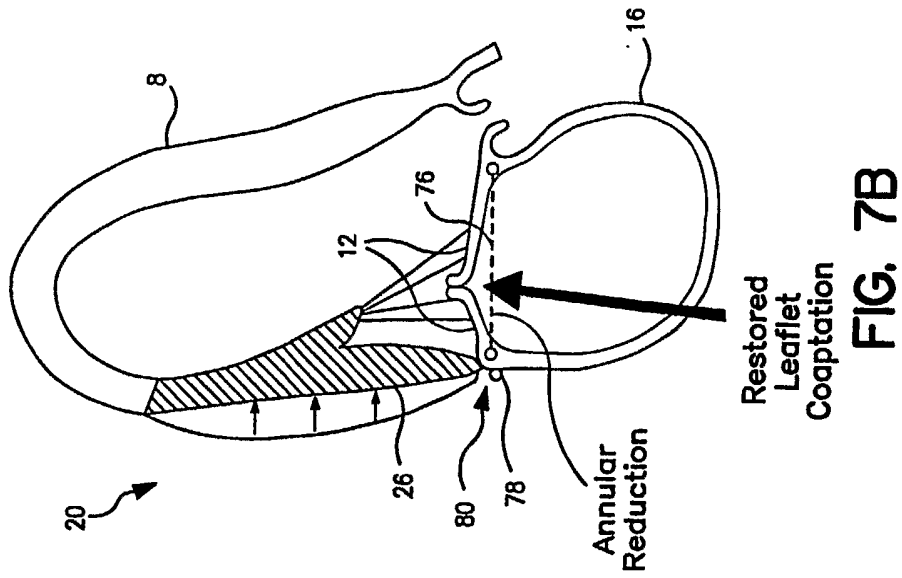

FIG. 7B

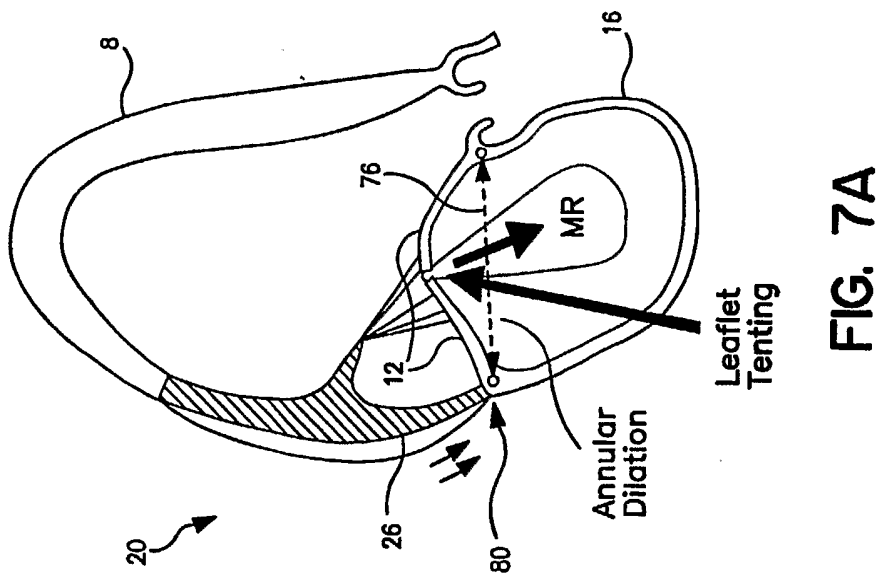

FIG. 7A

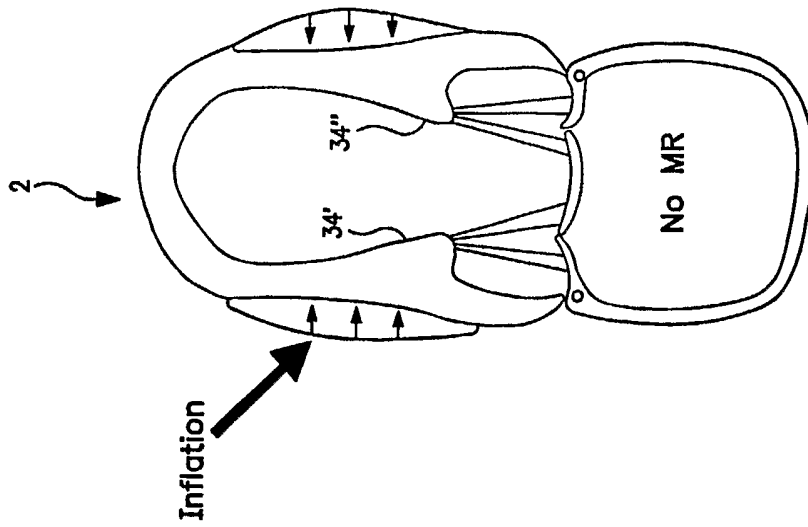

FIG. 8B

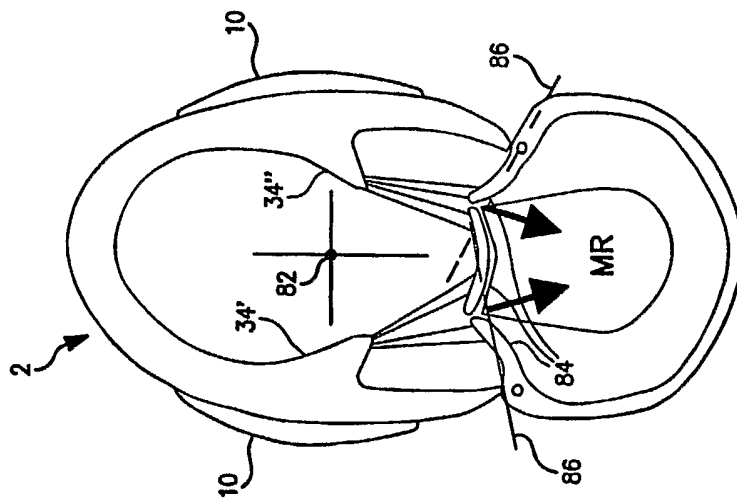

FIG. 8A

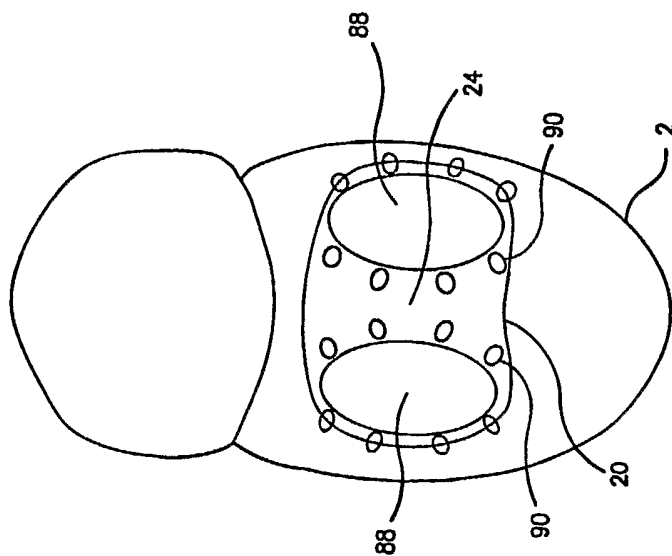

FIG. 8D

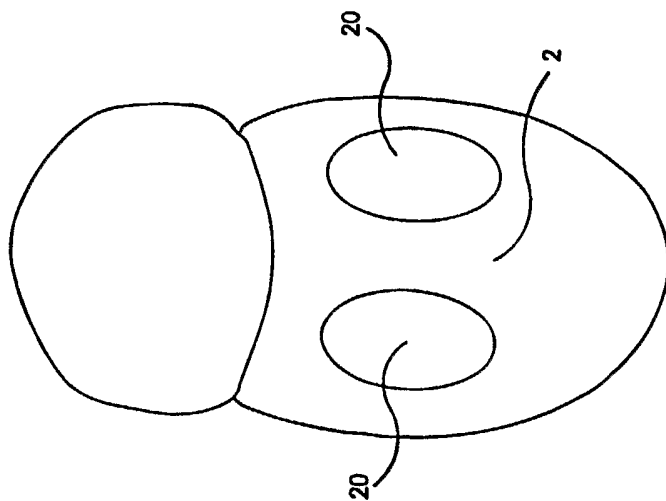

FIG. 8C

9 / 16

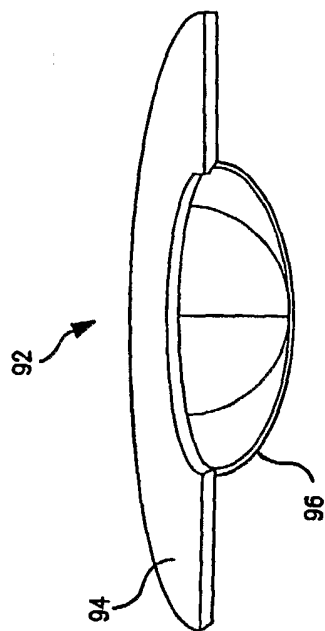

FIG. 9B

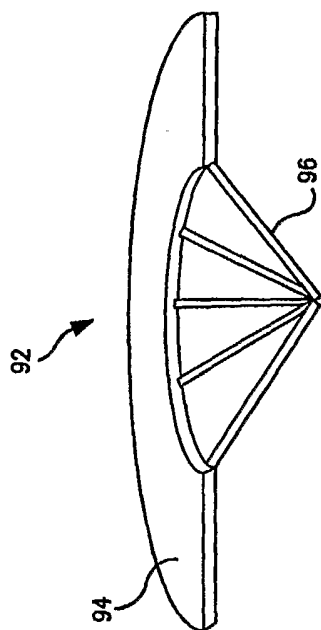
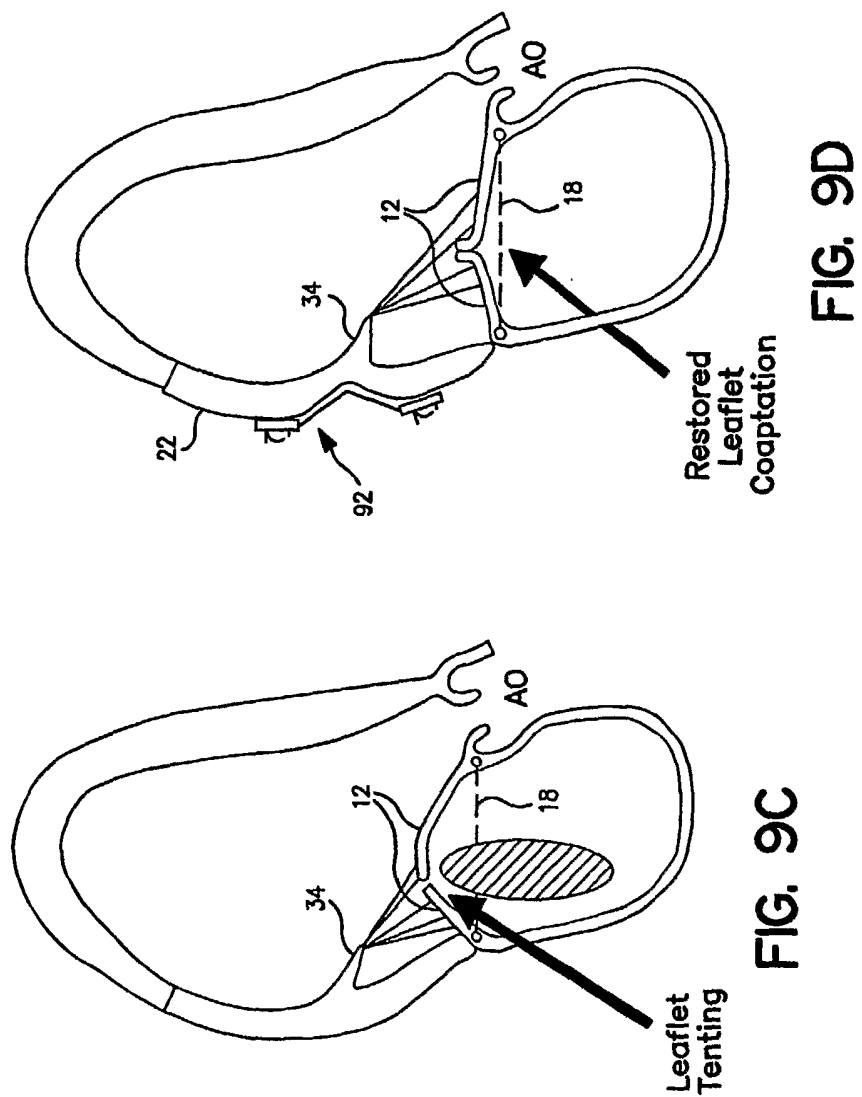
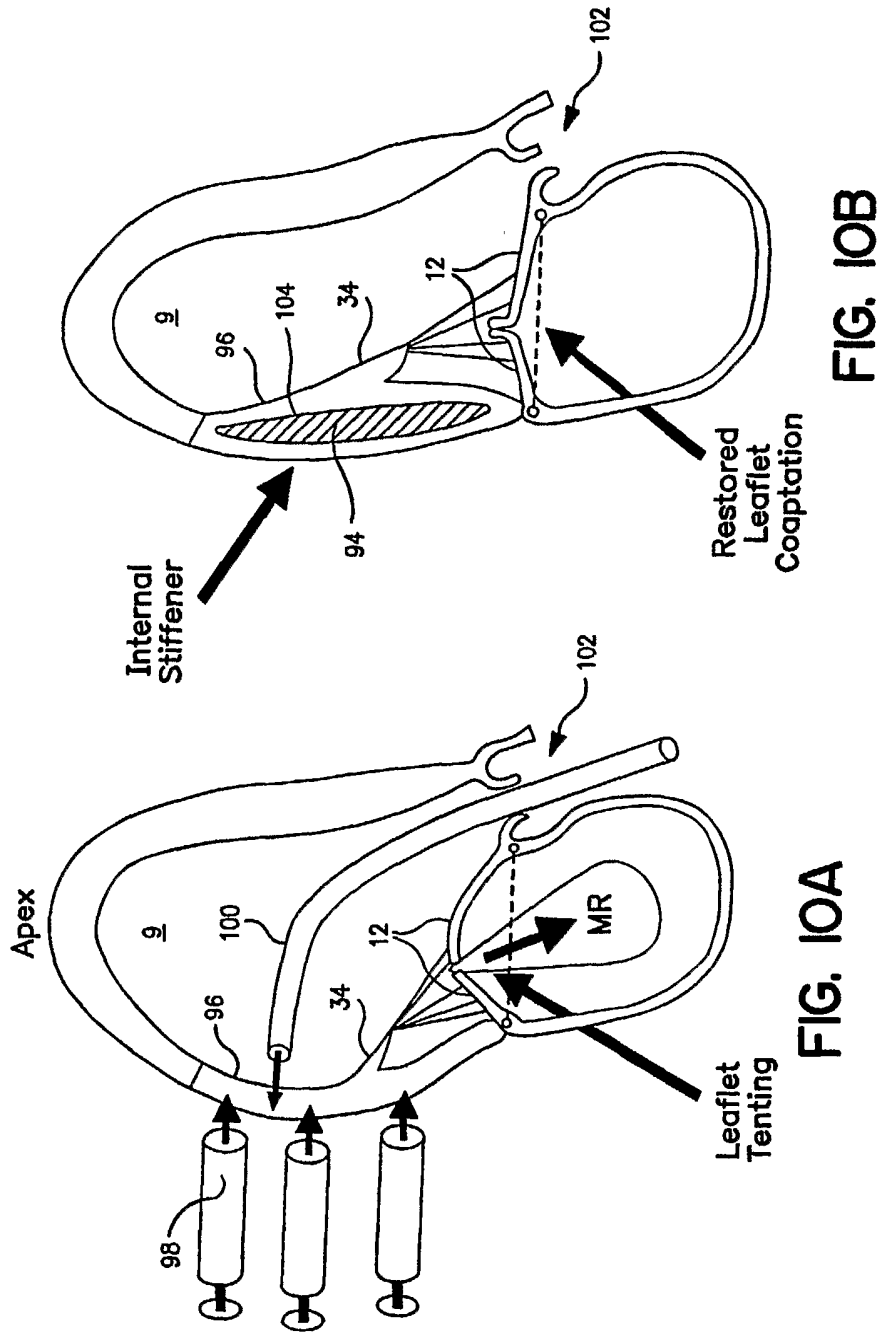

FIG. 9A





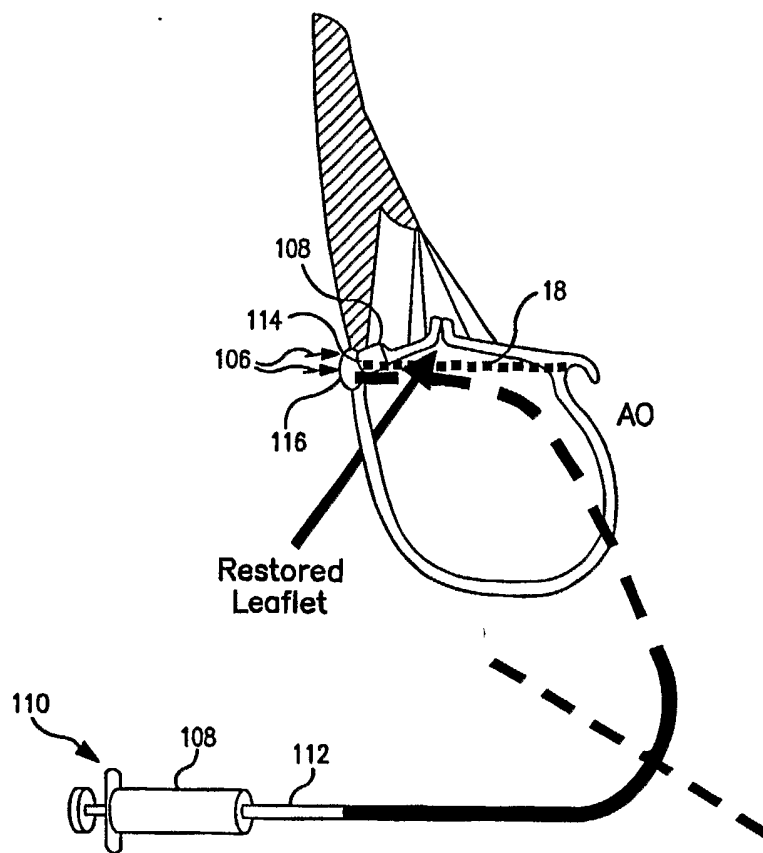

FIG. 11

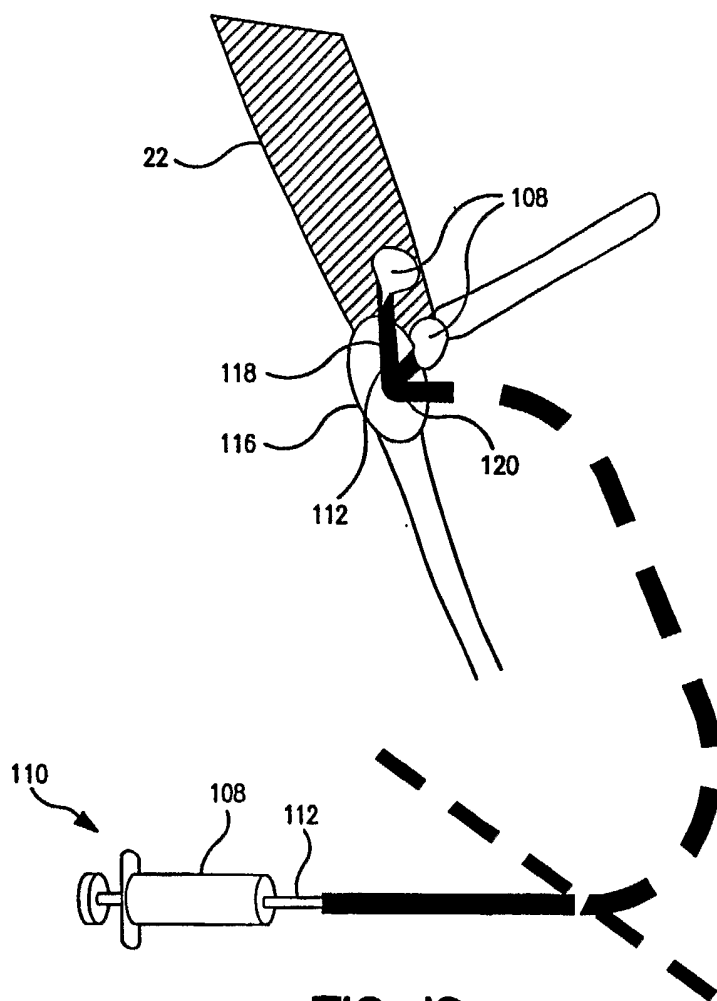

FIG. 12

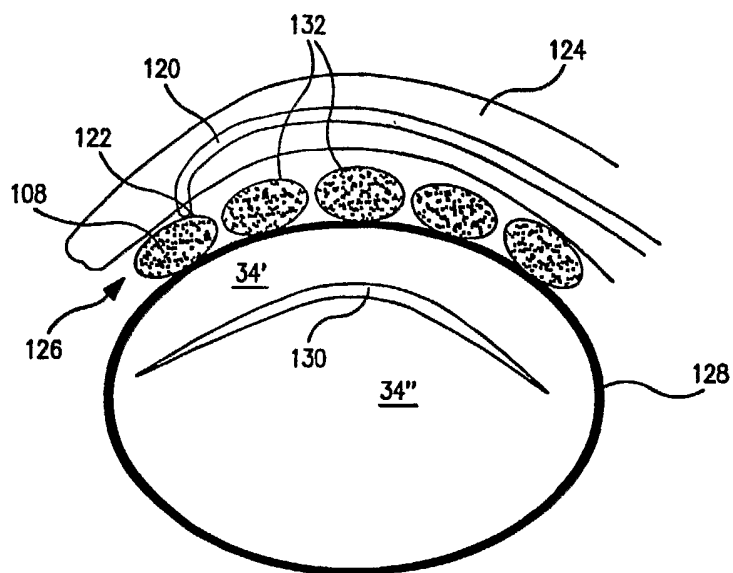

FIG. 13

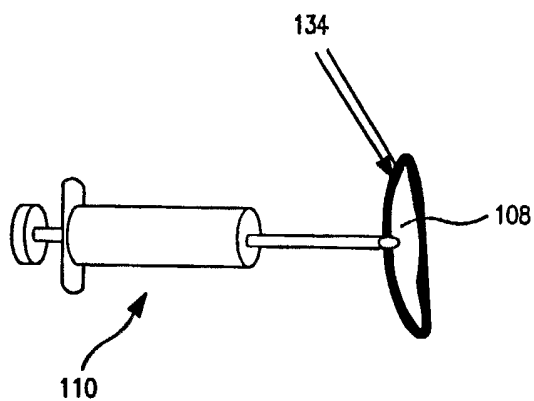

FIG. 14

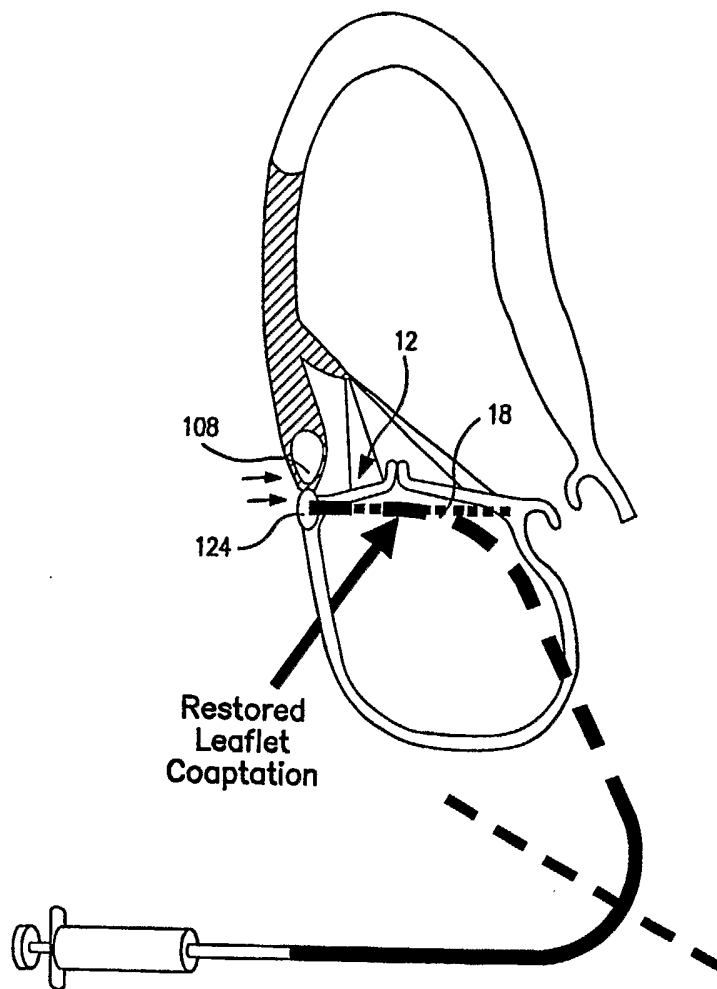

FIG. 15