

(19) World Intellectual Property Organization
International Bureau



(43) International Publication Date
4 July 2002 (04.07.2002)

PCT

(10) International Publication Number
WO 02/052150 A1

- (51) International Patent Classification⁷: F03D 11/04, B63B 21/50, 9/06, 35/44
- (21) International Application Number: PCT/NL01/00932
- (22) International Filing Date: 21 December 2001 (21.12.2001)
- (25) Filing Language: Dutch
- (26) Publication Language: English
- (30) Priority Data: 1016986 22 December 2000 (22.12.2000) NL
- (71) Applicant (for all designated States except US): BEHEERSMAATSCHAPPIJ P. BUITENDIJK B.V. [NL/NL]; Lindtsedijk 78, NL-3336 LE Zwijndrecht (NL).
- (72) Inventor; and
- (75) Inventor/Applicant (for US only): BUITENDIJK, Arie [NL/NL]; Grevelingen 33, NL-3332 VA Zwijndrecht (NL).
- (74) Agent: JORRITSMA, Ruurd; Nederlandsch Octrooibureau, Scheveningseweg 82, P.O. Box 29720, NL-2502 LS The Hague (NL).
- (81) Designated States (national): AE, AG, AL, AM, AT, AU, AZ, BA, BB, BG, BR, BY, BZ, CA, CH, CN, CO, CR, CU, CZ, DE, DK, DM, DZ, EC, EE, ES, FI, GB, GD, GE, GH, GM, HR, HU, ID, IL, IN, IS, JP, KE, KG, KP, KR, KZ, LC, LK, LR, LS, LT, LU, LV, MA, MD, MG, MK, MN, MW, MX, MZ, NO, NZ, OM, PH, PL, PT, RO, RU, SD, SE, SG, SI, SK, SL, TJ, TM, TN, TR, TT, TZ, UA, UG, US, UZ, VN, YU, ZA, ZW.
- (84) Designated States (regional): ARIPO patent (GH, GM, KE, LS, MW, MZ, SD, SL, SZ, TZ, UG, ZM, ZW), Eurasian patent (AM, AZ, BY, KG, KZ, MD, RU, TJ, TM), European patent (AT, BE, CH, CY, DE, DK, ES, FI, FR, GB, GR, IE, IT, LU, MC, NL, PT, SE, TR), OAPI patent (BF, BJ, CF, CG, CI, CM, GA, GN, GQ, GW, ML, MR, NE, SN, TD, TG).

[Continued on next page]

(54) Title: MAST CONSTRUCTION AND ERECTION METHOD FOR OFFSHORE INSTALLATION

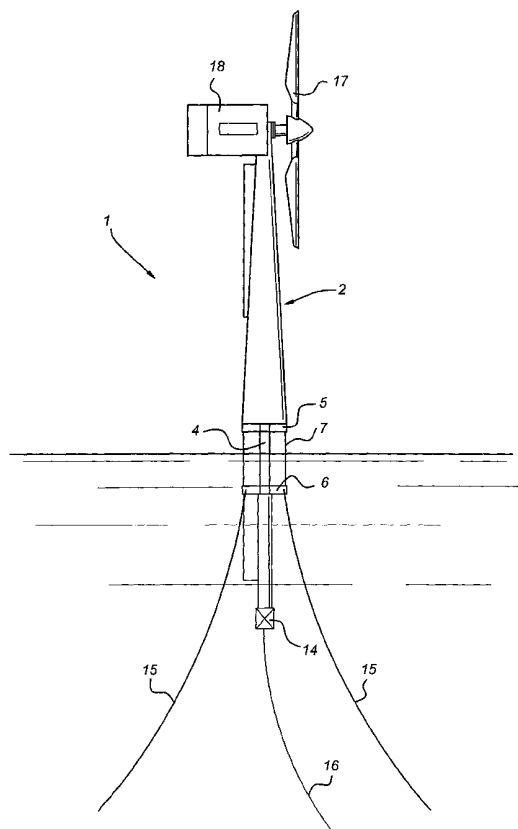

(57) Abstract: Mast construction for an installation to be installed floating on water. On part of the mast construction extends beneath the water level and one part, provided with the installation, extends above the water level. The part close to the surface of the water (4) has a smaller effective circumference in order to limit the effect of striking waves as much as possible. Tensioning cables (15) can optionally be present at the location of the part having the smaller effective circumference, so that the strength remains optimum.

WO 02/052150 A1



Published:

— with international search report

For two-letter codes and other abbreviations, refer to the "Guidance Notes on Codes and Abbreviations" appearing at the beginning of each regular issue of the PCT Gazette.

MASTCONSTRUCTIE ALSMEDE WERKWIJZE VOOR HET PLAATSEN DAARVAN VOOR OFFSHORE
INRICHTING

The present invention relates to a mast construction according to the precharacterising clause of Claim 1.

5 A mast construction of this type is disclosed in US Patent 3 092 852. The latter publication discloses an observation station, constructed in the form of a pipe, for earthquakes. This pipe is provided with ballast at the bottom and designed to be placed in the sea such that it floats. With this arrangement the installation contains an observation post.

10 It has been found that substantial forces act on the mast construction, in particular if such an installation is used offshore. Mast constructions of this type are therefore of relatively heavyweight construction.

The aim of the present invention is to be able to make such a mast construction of lighter weight, it being guaranteed that there is adequate strength under all conditions, that is to say that the device is always held in the correct position by that part of the mast construction that is below the water surface.

Said aim is achieved with a device as described above by means of the characterising measures of claim 1.

Any resulting loss of strength caused by the smaller diameter of the mast construction can be compensated for in that tensioning members, such as cables, extend between the adjacent parts, always at the outer periphery thereof. These tensioning members have high strength and a small surface area on which waves and the like can act. A stable construction can be obtained in this way. It is also possible to construct the intermediate part with approximately the same periphery as the parts adjoining the latter, but to provide large openings, as a result of which the surface area on which waves can act is reduced. That is to say, the effective periphery is locally reduced. With this arrangement it is possible to make the intermediate part of a material which has improved mechanical properties, compared with the surrounding parts.

For transport by sea it can be desirable to provide stabilisers in order to prevent “rolling” of the mast construction. Such stabilisers can be weights, fins and the like and are generally known per se in the state of the art.

According to a further advantageous embodiment, the mast construction is provided with connecting points for anchor cables or anchor chains. These are preferably arranged

on platforms with which the mast construction is provided.

The mast construction can also be provided with movement compensators which in the raised position are effective in heavy weather.

If such mast constructions have to be installed at sea, high installation costs and
5 maintenance costs are associated therewith.

In the prior art in general a platform is first provided that is anchored in some way or other to the seabed. This can be effected by providing the platform with legs which bear on the seabed (sinkable platform) or by using anchor constructions such as a spar construction in order to fix the platform in position. The invention relates to the latter variant. With such
10 a construction the part that extends below sea level will in general be provided with a weight in order to provide the necessary stability. After installation of the platform, for example with the aid of a large ship's crane or derrick, the previously produced mast construction is then installed on the floating platform. The turbine blade, which may or may not be provided with the generator, is fitted to the end of the mast construction at the
15 same time or later on.

The latter two operations require, on the one hand, the presence of an expensive crane and, on the other hand, good weather because such cranes or derricks cannot be used in stormy conditions. On the other hand, the intention is to install such wind turbines in more windy regions, so that it will be understood that the weather conditions desired for normal
20 operation are particularly undesirable at the time of installation.

This means that the installation costs are high.

When carrying out maintenance on the windmills and other installations it is necessary to climb into the mast construction, with all the associated risks. This means that if the maintenance is somewhat more extensive it is likely that it will be decided to remove
25 the generator/blades from the mast with the aid of a ship's crane and to carry out the necessary operations thereon either on site or on shore. This activity is also expensive.

A further aim of the present invention is to provide a wind turbine which can be installed in a less expensive and simpler manner, as a result of which the costs for generating energy are lowered, and the maintenance or overhaul of which can also be
30 carried out more easily and less expensively.

This aim is realised with a mast construction as described above in that the weight is fitted such that it is removable and in that said mast has buoyancy.

According to the present invention the mast construction is so constructed that it can

be transported in the horizontal position, that is to say lying down, to the installation site. The blades/generator are then fitted on site. It is also possible to fit these beforehand. The mast construction is then moved from the horizontal position into the desired vertical position by means of fitting a weight. A large expensive crane is not needed for this purpose.

It is pointed out that British Patent 2 344 843 A discloses a foldable mast construction for a windmill. With this construction the bottom part of the mast construction is fixed to the seabed.

According to an advantageous embodiment of the invention, the mast construction is provided with liquid-tight compartments, that is to say the mast is itself able to float on the surface of the sea. Consequently it is not necessary to transport the mast construction on a specialist vessel. With this arrangement the shape of the mast can be optimised for towing over water.

The invention also relates to a method for installing a windmill on water, comprising transporting a mast construction to the installation site and anchoring said mast construction at that site, transport comprising moving said mast construction in the horizontal position floating in the water and bringing said mast construction into the vertical position at the installation site.

Maintenance is also appreciably facilitated by means of the method and mast construction described above. After all, for more extensive maintenance work it is possible to perform the movement of the mast construction from the horizontal to the vertical position in the reverse sequence, so that the mast construction is brought into the horizontal position and is easily accessible.

In the horizontal position the generator is readily accessible. In this context it is, of course, possible to allow the mast construction to assume an approximately horizontal position, that is to say to allow the end where the generator is fitted to bear on a maintenance vessel, so that this part is readily accessible from all sides.

The invention will be explained in more detail below with reference to an illustrative embodiment shown in the drawing. In the drawing:

Fig. 1 shows, diagrammatically, the mast construction according to the invention during transport to the installation site;

Fig. 2 shows the mast construction according to the invention during erection; and

Fig. 3 shows the mast construction according to the invention in the installed

position.

In Fig. 1 the mast construction according to the present invention is indicated in its entirety by 1. This mast construction is floating on the surface 20 of the sea. The mast construction 1 consists of a first end 2 and a second end 3. The first end 2 is provided with a number of compartments 11, 12, 13 into which fluid, such as seawater, can be introduced and from which this fluid can be removed again. Such compartments (not shown) are also present in the second end 3.

An intermediate part 4 is arranged between the first end 2 and the second end 3. This intermediate part is delimited by the platforms 5 and 6. The intermediate part 4 has an appreciably smaller cross-section than the adjoining platforms 5 and 6. A series of tensioning cables 7 extends between the adjoining platforms 5 and 6. The space delimited by this means can be closed off by removable partitions for transport, in order to increase the buoyancy.

A fixing for a blade/generator assembly is indicated by 8, whilst 19 is the fixing end for a weight indicated diagrammatically by 14.

In the position shown in Fig. 1 a weight 9 is at the bottom of the mast construction and serves to stabilise the latter on the surface of the sea, that is to say prevents rolling. A centreboard 21 is present for the same purpose. A tug, by means of which the mast can be transported, is indicated diagrammatically by 10. By way of example, a value of approximately 125 metres is given for the length of such a mast construction, the first part having a length of approximately 68 metres and the second part a length of approximately 40 metres and the intermediate part being approximately 17 metres long. The diameter of the second part is approximately 6 metres.

It must be understood that these are examples only and the lengths and the length relationships can vary depending on the requirements. In the illustrative embodiment shown here, the platforms 5 and 6 have a diameter of between 8 and 10 metres and the diameter of intermediate part 4 is approximately 2 metres.

When the mast construction 1 according to the invention has arrived at its destination, the weight 14 is fitted. The generator 18 and the turbine blade 17 are also fitted (Fig. 2). The mast construction is tilted at the same time or subsequently. The first stage of tilting is shown in Fig. 2. The final stage is shown in Fig. 3. In the final stage the mast construction projects from the surface of the sea in the desired position.

It can also be seen from Fig. 3 that the intermediate part 4, which has an appreciably

reduced surface area on which the waves can act, is located at the surface of the sea. The stress at this location is consequently less. Furthermore, movement compensators can be fitted.

Positioning of the mast construction 1 takes place with the aid of tensioning cables
5 15 which are fixed to platform 6. 16 indicates the power cable by means of which the power generated is taken off.

If maintenance is desired, the mast construction is tilted back as shown in Fig. 2 and Fig. 1, respectively. Of course, the end of the first part 2 will then come to bear on a platform or the like in order to facilitate maintenance work on, for example, the generator
10 18.

Although the invention has been described above with reference to a preferred embodiment, it will be understood that numerous modifications can be made thereto without going beyond the scope of the present application.

For instance, the weight 14 can be of a different construction and (partially)
15 implemented with the aid of ballast tanks and the like. It is also possible for the wind turbine/generator assembly already to be fitted before transport by sea. These and further modifications fall within the scope of the appended claims.

Claims

1. Mast construction (1) for an installation to be installed floating on water, comprising an end (2) for mounting the installation thereon above the surface of the water, the other
5 end (3) of said mast being designed to be below the surface of the water, characterised in that said mast has an intermediate part (4) located between said ends, which intermediate part is at the level of the surface of the water, the effective circumference of which intermediate part is smaller than the circumference of the adjoining parts.
2. Mast construction according to Claim 1, wherein said intermediate part is delimited
10 by spaced platforms.
3. Mast construction according to Claim 2, wherein tensioning members (7) extending between said platforms are fitted close to the periphery of said platforms.
4. Mast construction according to one of the preceding claims, wherein said mast is provided on one side thereof with stabilisers (9) which counteract rotation about the
15 longitudinal axis thereof.
5. Mast construction according to one of the preceding claims, provided with connecting points for anchor cables (7).
6. Mast construction according to Claim 5, wherein said connecting points are arranged on one of the platforms.
- 20 7. Mast construction according to one of the preceding claims, wherein said installation is a windmill.
8. Mast construction according to Claim 7, wherein a weight (14) is fitted, such that it is removable/movable, on the other end (3) of said mast and wherein said mast has buoyancy.
9. Mast construction according to Claim 7 or 8, provided with liquid-tight
25 compartments (11-13).
10. Method for installing a windmill at sea, comprising transporting a mast construction to the installation site and anchoring said mast construction at this site, characterised in that transport comprises moving said mast construction in the horizontal position floating in water and bringing said mast construction into the vertical position at the installation site.
- 30 11. Method according to Claim 10, wherein one end of said mast construction is provided with blades receiving wind energy at said installation site.
12. Method according to Claim 10 or 11, wherein another end of said mast is provided with a weight at the installation site.

13. Method for inspecting/maintaining a windmill installed at sea, comprising a mast construction with a turbine/generator mounted on one end, characterised in that said mast construction is brought from the vertical position into the horizontal position.

Fig 1

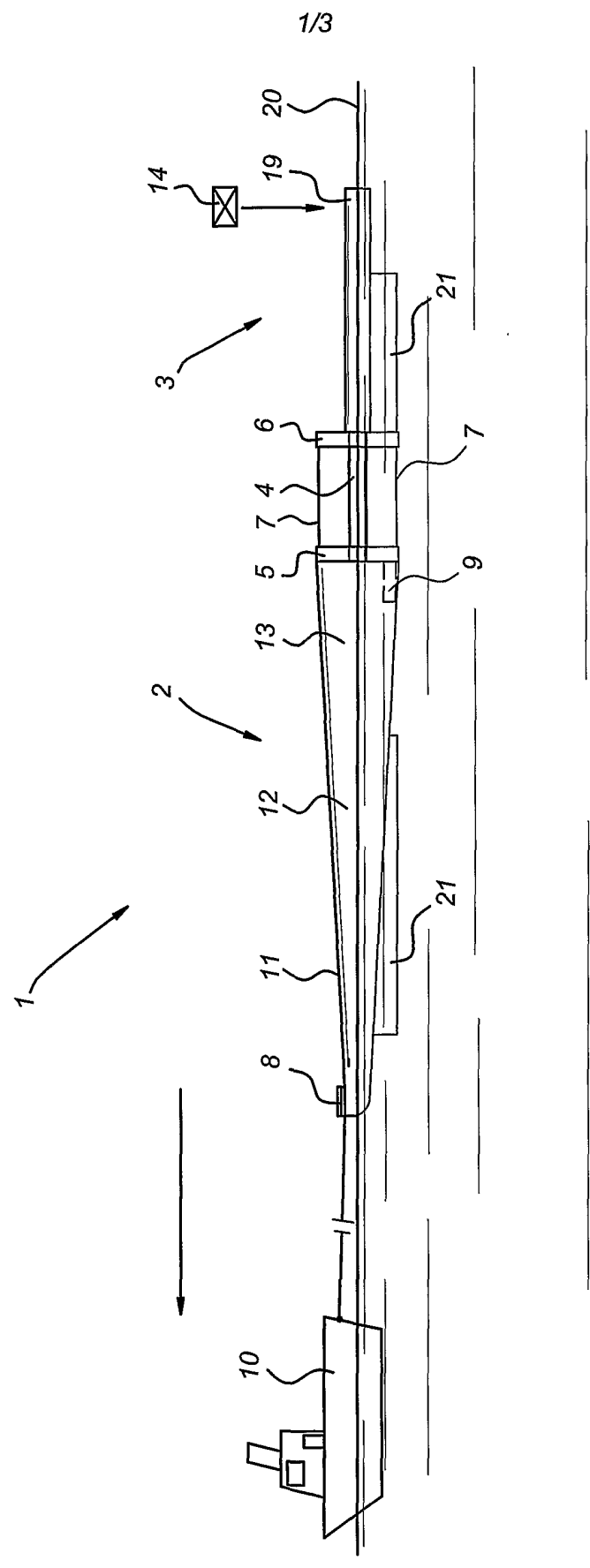

Fig 2

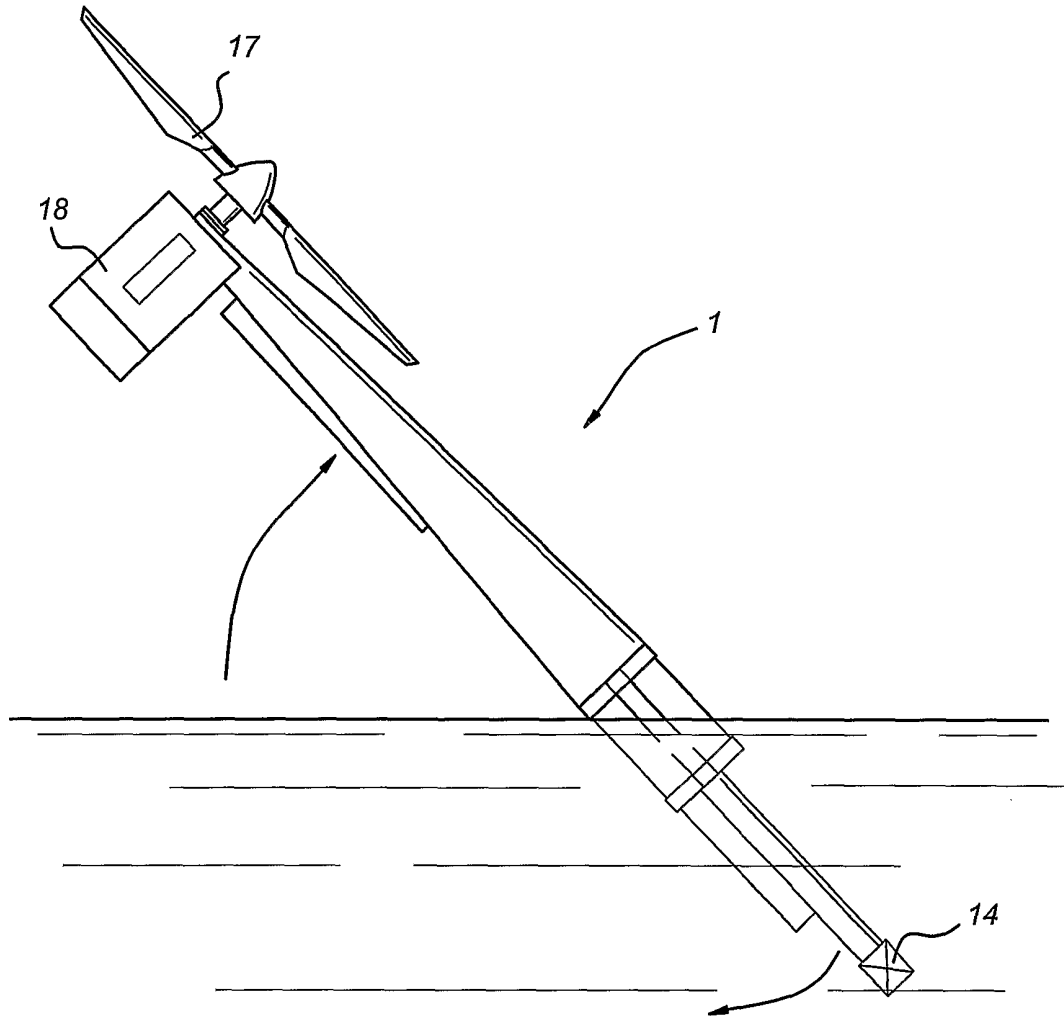
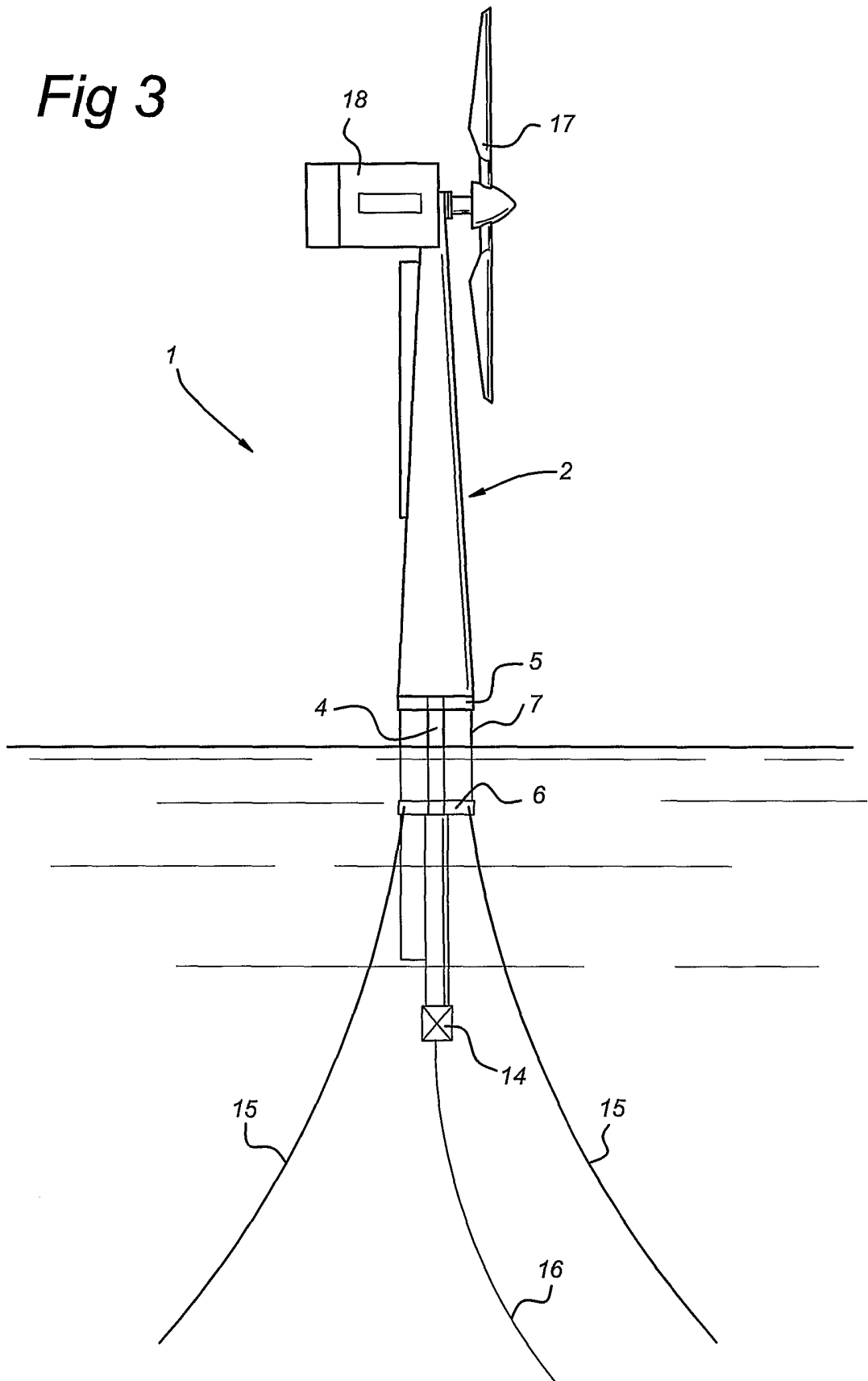

Fig 3



INTERNATIONAL SEARCH REPORT

International Application No

PC 1/INL 01/00932

A. CLASSIFICATION OF SUBJECT MATTER

IPC 7 F03D11/04 B63B21/50 B63B9/06 B63B35/44

According to International Patent Classification (IPC) or to both national classification and IPC

B. FIELDS SEARCHED

Minimum documentation searched (classification system followed by classification symbols)

IPC 7 F03D B63B

Documentation searched other than minimum documentation to the extent that such documents are included in the fields searched

Electronic data base consulted during the international search (name of data base and, where practical, search terms used)

EPO-Internal

C. DOCUMENTS CONSIDERED TO BE RELEVANT

Category °	Citation of document, with indication, where appropriate, of the relevant passages	Relevant to claim No.
A	GB 2 344 843 A (SIDOR NEVEN JOSEPH) 21 June 2000 (2000-06-21) cited in the application abstract page 6, line 11 - line 16 page 7, line 15 - line 25 figures ---	1-13
A	US 3 092 852 A (R.F.DEVEREUX) 11 June 1963 (1963-06-11) cited in the application column 2, line 33 -column 3, line 57; figures ---	1-13
A	NL 9 300 369 A (DIRK KATARINUS VERBURGH; VERSTEEG GIJSBERT) 16 September 1994 (1994-09-16) page 3, line 21 - line 23; figure 2 ---	4
	-/--	

 Further documents are listed in the continuation of box C. Patent family members are listed in annex.

° Special categories of cited documents :

- *A* document defining the general state of the art which is not considered to be of particular relevance
- *E* earlier document but published on or after the international filing date
- *L* document which may throw doubts on priority claim(s) or which is cited to establish the publication date of another citation or other special reason (as specified)
- *O* document referring to an oral disclosure, use, exhibition or other means
- *P* document published prior to the international filing date but later than the priority date claimed

- *T* later document published after the international filing date or priority date and not in conflict with the application but cited to understand the principle or theory underlying the invention
- *X* document of particular relevance; the claimed invention cannot be considered novel or cannot be considered to involve an inventive step when the document is taken alone
- *Y* document of particular relevance; the claimed invention cannot be considered to involve an inventive step when the document is combined with one or more other such documents, such combination being obvious to a person skilled in the art.
- * & * document member of the same patent family

Date of the actual completion of the international search

7 March 2002

Date of mailing of the international search report

26/03/2002

Name and mailing address of the ISA

European Patent Office, P.B. 5818 Patentlaan 2
NL - 2280 HV Rijswijk
Tel. (+31-70) 340-2040, Tx. 31 651 epo nl,
Fax: (+31-70) 340-3016

Authorized officer

Criado Jimenez, F

INTERNATIONAL SEARCH REPORT

International Application No

PCT/NL 01/00932

C.(Continuation) DOCUMENTS CONSIDERED TO BE RELEVANT

Category *	Citation of document, with indication, where appropriate, of the relevant passages	Relevant to claim No.
A	WO 98 29298 A (SHELL INT RESEARCH) 9 July 1998 (1998-07-09) abstract page 3, line 8 - line 21 page 4, line 29 -page 5, line 23; figures -----	1,2,5,6
A	FR 1 474 652 A (CAMMELL LAIRD) 9 June 1967 (1967-06-09) page 3, left-hand column, paragraph 9; figures -----	1
A	US 4 703 709 A (BEHAR ISAAC ET AL) 3 November 1987 (1987-11-03) -----	

INTERNATIONAL SEARCH REPORT

Inter national Application No

PCT/NL 01/00932

Patent document cited in search report		Publication date	Patent family member(s)	Publication date
GB 2344843	A	21-06-2000	NONE	
US 3092852	A	11-06-1963	NONE	
NL 9300369	A	16-09-1994	NONE	
WO 9829298	A	09-07-1998	BR 9714113 A WO 9829298 A1 GB 2334005 A ,B NO 992536 A	21-03-2000 09-07-1998 11-08-1999 26-05-1999
FR 1474652	A	24-03-1967	NONE	
US 4703709	A	03-11-1987	FR 2544688 A1 AU 570040 B2 AU 2708484 A BR 8401957 A CA 1305370 A1 ES 284683 U ES 287334 U GB 2139170 A ,B IE 55537 B1 IN 160623 A1 IT 1176074 B JP 59209579 A MT 946 A NO 841593 A ,B, OA 7709 A SU 1336946 A3 US 4766836 A	26-10-1984 03-03-1988 25-10-1984 04-12-1984 21-07-1992 16-03-1987 16-11-1985 07-11-1984 24-10-1990 18-07-1987 12-08-1987 28-11-1984 01-11-1984 22-10-1984 30-08-1985 07-09-1987 30-08-1988