

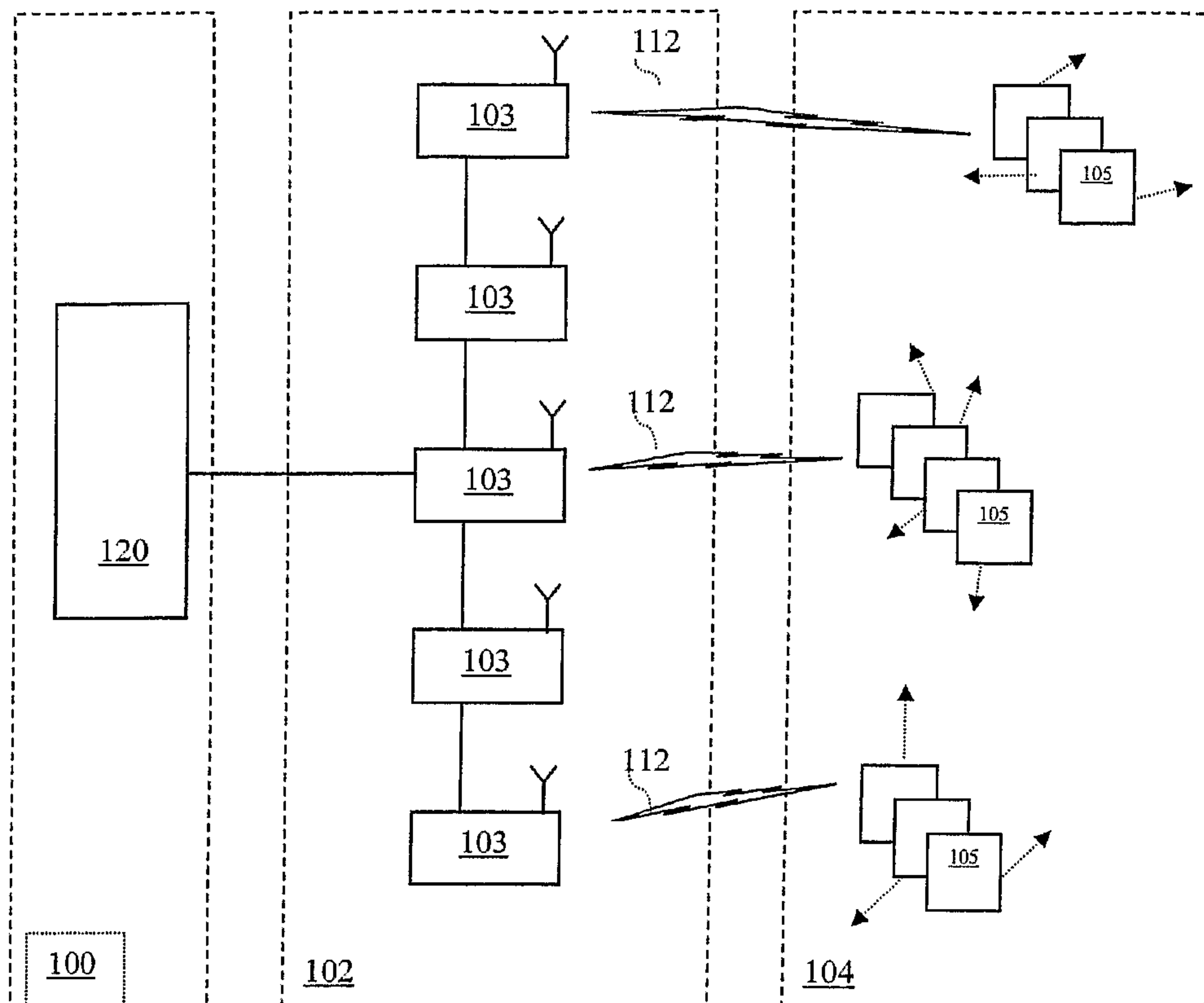

(86) Date de dépôt PCT/PCT Filing Date: 2007/03/02
 (87) Date publication PCT/PCT Publication Date: 2007/09/07
 (85) Entrée phase nationale/National Entry: 2008/09/02
 (86) N° demande PCT/PCT Application No.: GB 2007/000735
 (87) N° publication PCT/PCT Publication No.: 2007/099340
 (30) Priorité/Priority: 2006/03/03 (GB0604342.6)

(51) Cl.Int./Int.Cl. *G06K 7/00* (2006.01),
H04L 1/00 (2006.01)
 (71) Demandeur/Applicant:
WAVETREND TECHNOLOGIES LIMITED, GB
 (72) Inventeurs/Inventors:
VAN NIEKERK, CHICOT, ZA;
GOOSEN, STEFAN EBEN, ZA;
REDDY, DES, ZA;
NEUHOFF, CHARL, ZA;
EVANGELIDIS, ANDREW, ZA;
SCHOEMAN, ERICH, ZA
 (74) Agent: SMART & BIGGAR

(54) Titre : SIGNALISATION DANS UN APPAREIL D'IDENTIFICATION ELECTROMAGNETIQUE
 (54) Title: SIGNALLING IN ELECTROMAGNETIC IDENTIFICATION APPARATUS



(57) **Abrégé/Abstract:**

There is provided a method of signalling in an RFID network comprising active transponders and networked reader units deployed to receive communications from t transponders. The method comprises employing amplitude shift keying to encode data base on transitions between a high and a low signal according to a scheme in which respective ones of a plurality of bit combinations of binary numbers are transmitted as different predetermined delays between signal transitions.

(12) INTERNATIONAL APPLICATION PUBLISHED UNDER THE PATENT COOPERATION TREATY (PCT)

(19) World Intellectual Property Organization
International Bureau(43) International Publication Date
7 September 2007 (07.09.2007)

PCT

(10) International Publication Number
WO 2007/099340 A1

(51) International Patent Classification:

G06K 7/00 (2006.01) H04L 1/00 (2006.01)

P.O. Box 2999, Camerview, Johannesburg (ZA). **SCHOE-
MAN, Erich** [ZA/ZA]; P.O. Box 50259, Wiedrapark,
Centurion, Pretoria 0149 (ZA).

(21) International Application Number:

PCT/GB2007/000735

(74) Agents: **HILL, Justin, John** et al.; McDermott Will &
Emery UK LLP, 7 Bishopsgate, London EC2N 3AR (GB).

(22) International Filing Date: 2 March 2007 (02.03.2007)

(25) Filing Language: English

(26) Publication Language: English

(30) Priority Data:

0604342.6 3 March 2006 (03.03.2006) GB

(71) Applicant (for all designated States except US): **WAVE-
TREND TECHNOLOGIES LIMITED** [GB/GB]; 69
Athol Street, Douglas, Isle of Man IM1 1JE (GB).(81) Designated States (unless otherwise indicated, for every
kind of national protection available): AE, AG, AL, AM,
AT, AU, AZ, BA, BB, BG, BR, BW, BY, BZ, CA, CH, CN,
CO, CR, CU, CZ, DE, DK, DM, DZ, EC, EE, EG, ES, FI,
GB, GD, GE, GH, GM, GT, HN, HR, HU, ID, IL, IN, IS,
JP, KE, KG, KM, KN, KP, KR, KZ, LA, LC, LK, LR, LS,
LT, LU, LY, MA, MD, MG, MK, MN, MW, MX, MY, MZ,
NA, NG, NI, NO, NZ, OM, PG, PH, PL, PT, RO, RS, RU,
SC, SD, SE, SG, SK, SL, SM, SV, SY, TJ, TM, TN, TR,
TT, TZ, UA, UG, US, UZ, VC, VN, ZA, ZM, ZW.

(72) Inventors; and

(75) Inventors/Applicants (for US only): **VAN NIEKERK,
Chicot** [ZA/ZA]; P.O. Box 204, Pyramid 0120 (ZA).
GOOSEN, Stefan, Eben [ZA/ZA]; P.O. Box 5584,
0158 The Reeds (ZA). **REDDY, Des** [ZA/ZA]; P.O. Box
787222, Sandton, 2146 Gauteng (ZA). **NEUHOF, Charl**
[ZA/ZA]; 2 Manor Close, Norscot, Fourways, Johannes-
burg 2055 (ZA). **EVANGELIDIS, Andrew** [ZA/ZA];(84) Designated States (unless otherwise indicated, for every
kind of regional protection available): ARIPO (BW, GH,
GM, KE, LS, MW, MZ, NA, SD, SL, SZ, TZ, UG, ZM,
ZW), Eurasian (AM, AZ, BY, KG, KZ, MD, RU, TJ, TM),
European (AT, BE, BG, CH, CY, CZ, DE, DK, EE, ES, FI,
FR, GB, GR, HU, IE, IS, IT, LT, LU, LV, MC, MT, NL, PL,
PT, RO, SE, SI, SK, TR), OAPI (BF, BJ, CF, CG, CI, CM,
GA, GN, GQ, GW, ML, MR, NE, SN, TD, TG).

[Continued on next page]

(54) Title: SIGNALLING IN ELECTROMAGNETIC IDENTIFICATION APPARATUS

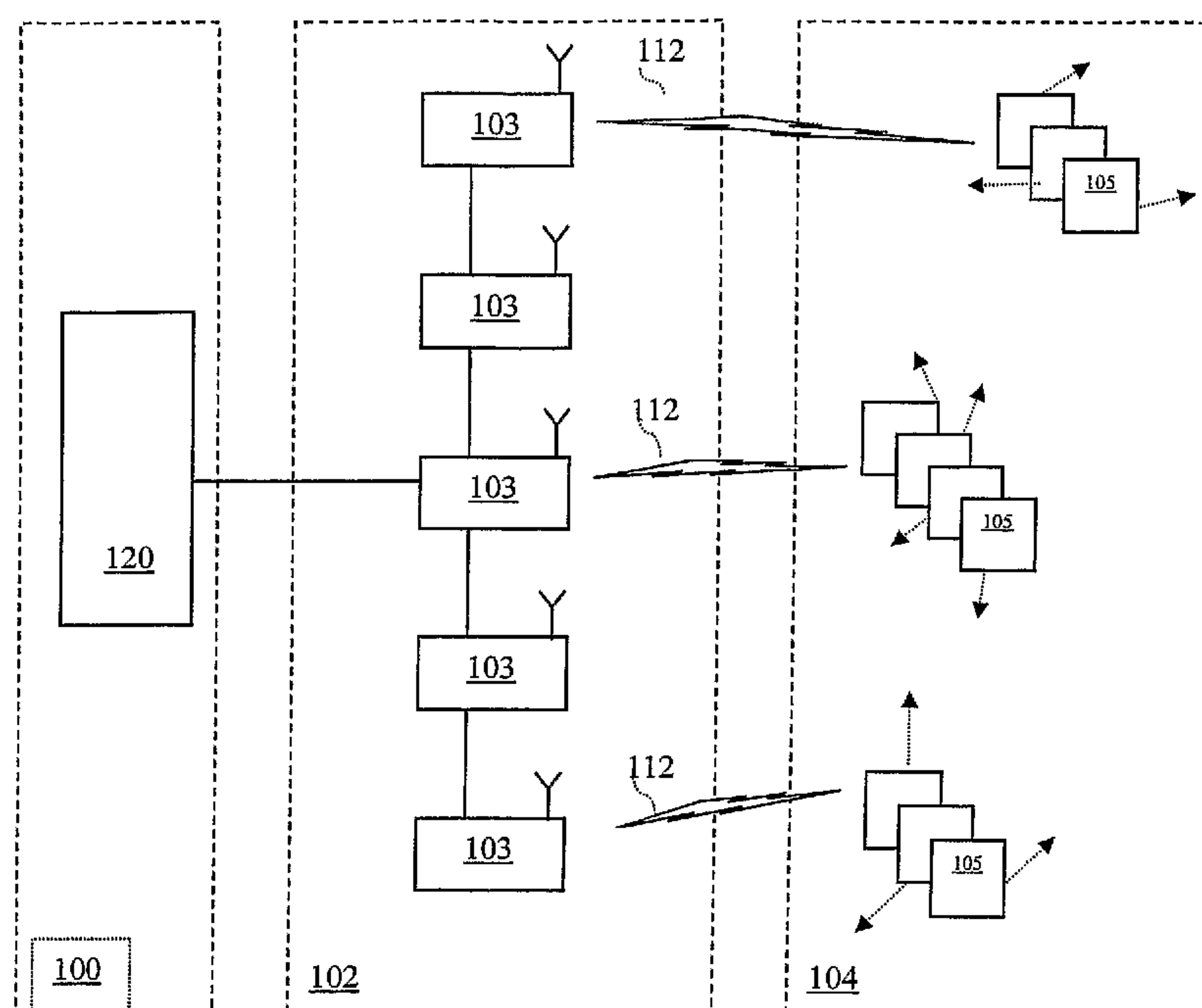

(57) Abstract: There is provided a method of signalling in an RFID network comprising active transponders and networked reader units deployed to receive communications from the transponders. The method comprises employing amplitude shift keying to encode data based on transitions between a high and a low signal according to a scheme in which respective ones of a plurality of bit combinations of binary numbers are transmitted as different predetermined delays between signal transitions.

WO 2007/099340 A1

WO 2007/099340 A1



Published:

— *with international search report*

For two-letter codes and other abbreviations, refer to the "Guidance Notes on Codes and Abbreviations" appearing at the beginning of each regular issue of the PCT Gazette.

SIGNALLING IN ELECTROMAGNETIC IDENTIFICATION APPARATUS

FIELD

This invention relates to electromagnetic identification systems, for example of a type
5 commonly referred to as radio frequency identification (RFID) systems, devices for use in
RFID systems and methods for operating such systems and devices. In particular,
embodiments of the invention relate to active transponder tags, networked reader devices, and
signalling schemes suitable for communications over the wireless interface between such tags
and readers.

10

BACKGROUND

RFID apparatus are a type of automatic identification system and, as such, provide
means for collecting, monitoring and tracking systems. Known types of RFID networks use
“passive” and “active” tags (transponders), although not always in the same network. A
15 “passive” tag is a miniature transponder capable of returning a response to a stimulus from a
reader device. Passive tags tend not to have a power source and so respond with energy from
backscattering or by harnessing electrical induction effects in antennae.

An “active” tag relies on its own transmitter for communicating with reader devices
20 over the air interface and therefore usually also includes a power source and microcontroller.
As advances in active tag design enable the mass production of higher performance tags at
lower costs, active tag technology can be expected to be deployed more widely in all types of
RFID networks. In more sophisticated deployments active tags can be programmed to enable
aspects of their function to be defined by the user, typically an RFID network administrator.

25

Applications for RFID technology are many and varied. However, applications include all manner of automatic identification, access, monitoring, tracking and remote sensing applications applied with personnel, animals, products and other assets.

5 As this technology has developed, the term "radio frequency" has been used increasingly broadly, to refer for example to such apparatus and methods employing a considerable range of frequencies of the electromagnetic spectrum in wireless communications. See for example Table 1, below which sets out typical frequencies which may be encountered:

10

TERM OF REFERENCE	TYPICAL FREQUENCY
Low Frequency	30 kHz to 300 kHz
Medium Frequency	300kHz to 3MHz
High and Very High Frequency	3 MHz to 300 MHz
Ultra-high Frequency	300 MHz to 2 GHz
Microwave	2 GHz to 6 GHz and beyond

Table 1: Terms of reference in RFID art and associated frequency ranges

Even the ranges indicated above are exemplary only for RFID applications and should not be construed as limiting. Within each frequency range indicated above, certain frequencies tend to be selected, for example, based on the availability of unlicensed spectral bands, standards, local legislation or other criteria. Low frequency applications often use 125 kHz or 134.2 kHz; high frequency applications often use 13.56 MHz; UHF applications tend to employ 433 MHz, 463 MHz, 868 MHz, 915 MHz or 956 MHz; and microwave

applications typically use 2.45 GHz or 5.8 GHz. However, a skilled person will appreciate that any suitable range corresponding to one or more of the exemplary ranges in Table 1 (or any combination) may be used with embodiments of the present invention. In some circumstances, embodiments of the present invention may employ frequency ranges outside
5 those indicated in Table 1 and which are still suitable for wireless communication.

Increasingly, RFID applications require large and diverse populations of tags, often deployed in with high tag densities (100 tags per reader) and in rapidly evolving scenarios. As tag performance and the number of functions supported by tags increases to meet these
10 demands, it becomes increasingly difficult to keep the cost of production down at acceptable levels for large scale deployments.

Embodiments of the present invention seek to provide improved electromagnetic identification systems, and particularly improved RFID networks, including active tags, reader devices, and communication protocols suitable for air interface communications
15 between tags and readers in RFID networks.

SUMMARY

20 According to an aspect of the present invention, there is disclosed a method for signalling in an RFID network comprising active transponders and networked reader units deployed to receive communications from said transponders, the method comprising:

employing amplitude shift keying to encode data as based on transitions between a high and a low signal according to a scheme in which respective ones of a plurality of bit

combinations of binary numbers are transmitted as different predetermined delays between signal transitions.

5 Preferably, each said predetermined delay comprises a delay between consecutive high signal states. In the disclose embodiment each predetermined delay indicates a two-bit combination of binary numbers.

10 The duration at a high signal state is preferably less than or equal to the duration of the shortest predetermined delay between high signal states. In the disclosed embodiment the duration of a high signal state is a value selected from one of the following ranges: 40 to 5 μ s; 30 to 10 μ s; and 25 to 15 μ s. Still more preferably the duration of a high signal state is about 20 μ s.

15 In the disclosed embodiment, the shortest predetermined delay between high signal states is greater than 20 μ s. Preferable at least first and second of said predetermined delays differ from each other by about half the duration of the shortest interval. In one embodiment first, second, third and fourth delays comprise different durations selected respectively from the ranges: 18 to 38 μ s; 32 to 52 μ s; 48 to 68 μ s and 62 to 82 μ s. In another embodiment, a first, second, third and fourth of said predetermined intervals are respectively about 28 μ s; 42 μ s; 58 μ s and 72 μ s.

In the disclosed embodiment a synchronisation signal is applied ahead of said data signal. Preferably said synchronisation signal comprises a predetermined plurality of pulses. Still more preferably, one or more of said pulses comprises a high signal state for a period

between 100 and 300 μ s. Typically intervals between pulses comprise a period of between 50 and 70 μ s.

Additional advantages and novel features of the invention will be set forth in part in the description which follows, and in part will become apparent to those skilled in the art upon examination of the following and accompanying drawings or may be learned by practice of the invention.

BRIEF DESCRIPTION OF THE DRAWINGS

10 For a better understanding of the present invention and as to how the same may be carried into effect reference will now be made, by way of example only, to the accompanying drawings, in which:

Figure 1 shows an exemplary RFID network;

Figure 2 shows an exemplary mesh network organisation;

15 Figure 3 shows a reader device according to an embodiment of the present invention;

Figure 4 shows a message package structure according to an embodiment of the present invention;

Figure 5 shows a response message package structure according to an embodiment of the invention;

20 Figure 6 shows a tag transponder according to an embodiment of the invention;

Figures 6A and 6B show respectively exemplary synchronisation and data encoding signals;

Figure 7 shows a general message for use in communications between tags and readers;

Figures 8A-8G show a plurality of exemplary tag message package formats;

Figure 9 shows a generalised message package structure for further potential tag classes; and
Figure 10 shows an exemplary process for the processing of tag data.

DETAILED DESCRIPTION

5

Fig.1 shows an exemplary RFID network according to an embodiment of the present invention. The network has a control interface 100 including an application server 120 for running an application program, a reader network 102, and a plurality of transponder tags 104, at least some of which are "active". The numerous individual tags 105 are deployed, for example, on products or other assets, animals or humans, or combinations thereof.

The reader network 102 can be any hardwired or wireless network capable of being organised to support physically distributed readers 103 arranged to receive data from the tags 105 over the air interface 112, and to relay this information back to the control interface 100, as will be explained in more detail hereinafter. Whereas in conventional RFID networks readers are not always configured to send messages to tags and instead act as receive-only nodes for messages from tags, in the present embodiment each reader 103 can additionally send certain types of messages to tags 105 in its field via the air interface 112. Although, the exemplary reader network 102 in Fig. 1 is organised linearly, a skilled person will appreciate that a range of known, and future, network organisations may be used as the backbone of the reader network, for example the mesh network organisation shown in Fig. 2.

Fig. 3 shows an exemplary reader device 103 according to embodiments of the present invention. The reader 103 comprises an RF module 300 having an antenna and receiver circuitry. The RF module is coupled to a microcontroller 302. The microcontroller

25

302 has access to a non-volatile re-writeable memory 304 and is also independently connected to an indicator circuit 306 and the reader network interface circuitry 308.

In use, the RF module 300 receives analogue radio frequency signals transmitted
5 from tags within effective radio range of the reader and converts these signals to digital data by means of known analogue-to-digital conversion technology. The RF module 300 also includes buffers and the like (not shown) to queue inbound messages from tags ahead of processing by the microcontroller 302. The microcontroller 302 can access control information residing either locally (within the microcontroller) or in the memory 304. The
10 microcontroller uses this control information to control the reader operations. In particular the microcontroller 302 controls the processing of tag messages it receives from the RF receiver 300 and the processing of reader network messages received from, and placed onto, the network interface 308. In this embodiment the indicator circuit 306 has a plurality of LEDs which may be used, where desired, to indicate status of the reader.

15

The reader network 102 is automatically scalable so that readers can be added as desired. The reader network 102 also allows the application program to individually address reader nodes 103, and therefore direct messages to individual reader nodes. In this embodiment it is also possible for the application program to address and direct messages to
20 all nodes 103 or to groups (subsets) of nodes 103. The messages sent over the reader network may be bound for the application 120, a reader node or nodes 103, or a tag or tags 105. General network architectures capable of supporting these routing criteria will be known to a skilled person.

The reader network 102 handles two basic classes of application messages, “command messages” and “response messages”.

Fig. 4 shows an exemplary message packet structure suitable for command messages transferable through the reader network. With reference to Fig. 4, the command message packet includes a header portion 402 indicating the message is a command message, a further field 404 indicating the number of bytes in a data section of the message, one or more further fields 406 including network addressing information such as reader node(s) ID and if appropriate tag ID or multiple tag IDs, a field 408 indicating the command type, a data field 410, and a checksum 412. The overall length of the command message packet and the relative sizes of various fields within it will depend for example on the application, message configuration, network organisation and scale.

The number and nature of different command types supported by the reader network 102 will depend in particular on the application(s) but typically includes, for example: Get Tag Data; Tag Wake Up; Tag Sleep; Network Reset; Set Mode; Set Address Information; Set System Information; Measure Signal Strength (RSSI); Set Receiver Gain; Set Alarm Criteria; Set Report Criteria; Set Baud Rate; and Get Version information. Commands such as Get Tag Data, Tag Wake Up and Tag Sleep support so called “speak when spoken to” applications. This type of application operates such that communications from tags are minimised or eliminated altogether unless a tag is specifically addressed by a reader. Speak when spoken to applications are important for example where the deployment has high tag densities, local legalisation precludes ordinary levels of beaconing or tag battery life needs to be extended beyond normal bounds.

25

Fig. 5 shows an exemplary response packet structure, for response messages transferable through the reader network. With reference to Fig. 5, the response packet includes a header portion 502 indicating the message is a response message, a field 504 indicating the number of bytes in a data section of the message, a field 506 including network addressing information such as node(s) ID or equivalent information, a field 508 indicating the response type, a tag data field 510, and a checksum 512. The overall length of the message and the length and configuration of the various fields within it will depend for example on the application, message configuration, network organisation and scale.

The number and nature of different response message types supported by the reader network 102 may vary but typically includes at least response types for all supported commands for which the application might expect a response. In this embodiment the contents of the response type field 508 replicates that of the command type field in the corresponding command. For example in the case of a response message to a "Get Tag Data" command, the response type field is identical to the command type field present in the issued command message. This combination of fields indicates that the response message packet contains relevant data from the tag probed by the corresponding command message. In this embodiment the tag data field contains the entire contents of the message packet from the relevant tag to its reader, albeit after conversion from analogue to digital and after having been packaged in to the larger reader network message by the components of the reader. Exemplary tag message packet content is described hereinafter with reference to Fig. 7.

Fig. 6 shows a tag transponder suitable for use with embodiments of the present invention. The tag has a microcontroller 602, an external programming interface 604, a plurality of peripheral devices, such as sensor devices 606 and counter devices 605, a power

supply 608 such as a battery, and an RF transceiver module 609 provided with an oscillator 610 and an antenna 612. In this embodiment, the RF circuit transmits at a frequency of 433.92 MHz. A memory 620 stores the unique identity of the tag, tag data recorded by the peripherals and control code for controlling tag operations such as building and scheduling 5 messages destined for the reader network. Alternatively, or in addition, control code may be stored in a local memory of the microcontroller 602.

In general, the tags deployed in a given network may comprise a mixture of active and passive tags, and among the active tags different sensor capabilities may be supported. The 10 peripheral devices typically include two or more peripherals capable of sensing an aspect of the external environment or location or event applying to the tag. For example, here the peripherals include a number of different sensors and counter devices. The counters can record for example the number of transmissions by the tag or the number of times a particular sensor or other peripheral is activated. In this embodiment a plurality of different sensors is 15 provided and the air interface protocol supports communication of tag data relating to the plurality of sensors and the counter devices simultaneously. In practice, sensor types may include two or more sensors selected from a temperature sensor, a location sensor (GPS receiver or the like), a movement sensor (accelerometer or the like), a vibration sensor, other mechanical sensors (such as a latch), a tamper circuit, a chemical sensor, a biological sensor, 20 a biometric sensor, a seismic sensor, proximity sensor, magnetic sensor, force sensor, strain sensor, humidity sensor, position sensor, rotary sensor, light sensor, pressure sensor etc...

Exemplary embodiments with two or more sensor functions include:

- Tags with movement and tamper
- 25 Tags with tamper and temperature

Tags with GPS and accelerometer and tamper

The examples and combinations are not intended to be limiting and a skilled person will readily appreciate that a considerable number of different multi-peripheral combinations can be supported, including sensor combinations involving two, three, four, five, six or more sensor types, depending on the application or applications.

In this example the RF transceiver circuitry 609 is configured to transmit at 433.92 MHz, which is an unlicensed band in most countries. The tags typically also comply with well known FCC, SATRA, CE and ETSI requirements. In other embodiments a tag may support transmission to the reader network 102 at any frequency indicated, or proximate to those indicated, in the ranges of Table 1, or indeed combinations of such frequencies. The or each tag 105 can be programmed to transmit for example at predetermined regular intervals, at irregular or random intervals, according to predetermined timing sequences, and/or based on frequency hopping algorithms. Further, or in addition, tags may be programmed to transmit in response to being addressed by a reader, and in certain embodiments to transmit only in response to such an address (so called "speak when spoken to" configurations). In certain embodiments a tag can respond to a reader after predetermined delays and this may be used as a mechanism for assigning transmission slots to a plurality of tags in the field of a particular reader. Such techniques have particular application in deployments involving high tag densities.

In this embodiment aspects of tag functionality, and particularly peripheral functions, can be programmed by a user via the programming interface 604. Such programmability is particularly useful in for example sophisticated remote sensing applications. For example

where the sensors include a temperature sensor, a tag can be programmed to send an alert (or regular readings) in response to predetermined temperature conditions or a specific pattern of temperatures. As another example, a tag with a GPS location sensor and a temperature sensor may be programmed to send temperature data when the tag is within a certain geographic area. In another embodiment, where a tag includes a biometric sensor it can be programmed with codes representative of individuals likely to employ the sensor. As another example, a tag with a temperature sensor, humidity sensor and pressure sensor may be programmed to send pressure data only if the temperature measurement and the humidity measurement falls within a preconfigured range.

10

The programming interface 604 typically includes a reed switch circuit, or suitable alternative device, representing an external programming interface via which the user can program aspects of the tag directly, namely without necessarily programming via the reader network. In alternative embodiments, the tag programming interface 604 may include an RF receiver module capable of operating at a different frequency to the main RF module 609 of the tag (for example so called "dual band" tags). In this case it is possible to program tags, or to re-program them, remotely, i.e. through the reader network.

15

In general, any suitable modulation technique may be used over the wireless interface 112 between the tags 105 and readers 103. In this embodiment, amplitude shift keying ASK is used (with a modulation depth of 90%).

20

Fig. 6A illustrates a synchronisation signal suitable for use by tag transmission circuitry, and Fig. 6B shows an exemplary data encoding scheme. Synchronisation information 650 is required because the wireless channel between the tag and reader is asynchronous. A reader receiving the synchronisation information detects the synchronisation

25

information as an indication of when to start reading data packets from the tag. The synchronisation information is also used by the reader to train its receiver circuitry to a suitable gain level. In this embodiment, the exemplary synchronisation signal is a predetermined sequence of pulses. Each of the first, second and third synchronisation pulses
 5 652, 654, 656 have a duration of 200 μ s and a subsequent delay of 60 μ s. Advantageously, this synchronisation scheme optimises the range between a tag and a reader, while minimising the power consumption.

Fig. 6B illustrates an exemplary data encoding and compression scheme which transmits 2 bits per delay (or in other words 2 bits per on/off switch of the RF pulse). Each of
 10 the four possible two-digit combinations of zeros and ones are represented by a different delay between pulses. Exemplary delay times, x , for the two-digit combinations are as illustrated in table 2.

Nibble	Delay (x , μ s)	Tx time /23 bytes (ms)	RF on time (ms)	Effective Baud Rate
00	28	4.416	1.84	41666.66
01	42	5.520	1.84	33333.33
10	58	6.624	1.84	27777.77
11	72	7.728	1.84	23809.33

Table 2: Exemplary data encoding parameters

15 With reference to Table 2 it can be seen that the disclosed embodiment uses 20 μ s RF pulse durations with intermittent delays selected from 28, 42, 58 and 72 μ s, in dependence on the two-bit combination to be transmitted. Most power is consumed during the high signal state of the pulses. The high signal states of 20 μ s are optimized to maximize dynamic read range and minimize power consumption. With reference to Fig. 6B it can be seen that by

selection of the delays between pulses the scheme can be used to transmit any sequence of binary numbers. RFID applications preferably require the transmitter circuitry to be capable of generating pulses with decay times of less than 11 μ s and attack times of less than 5 μ s. Advantageously, the disclosed data encoding scheme optimises data throughput without unduly requiring an unduly complicated signalling scheme.

At the reader, the RF receiver circuitry receives a degraded signal with characteristics depending on the properties of the radio channel linking the tag and the reader. For example, relative pulse width tends to decrease with transmission distance and so if the receiver is far from the tag (say more than 200 m) then the delays are relatively long compared with the delays of the originally transmitted signal. On the other hand, when the receiver is close to the tag (say within 0.5 m) the pulses are broadened and the received delays may be significantly shorter than the transmitted delays. These aspects make reliable detection over varying reader-tag distances difficult to achieve. The disclosed embodiment solves this problem by providing readers configured to process the encoded signal by determining corresponding delays based on sampling between the rising edges of adjacent pulses. In this way, the sampled duration turns out to be a better approximation of the approximation of the delay in the originally transmitted signal and this means the RFID network can work reliably in more diverse deployments.

A skilled person will readily appreciate that other suitable modulation techniques may be used in different embodiments of the invention, for example FSK QBPSK, BPSK and the like. Further aspects of the wireless tag-reader protocol are defined herein below with reference to Fig. 7. Aside from synchronisation information, tag message packets tend to include: a header 702 indicating the message is a tag and its length; a tag class field 704 (which may also indicate a tag type within a class and/or a particular mode of operation), a

tag unique ID field 706, a data field 710, and error checking information 712. In practice, the overall length of the message and configuration of the various fields within it will depend for example on the tag class.

5 The header information is used to achieve packet level synchronisation and to identify the type of message and its length in bytes. Another example of information typically included in the header is repetition rates for beaconing tags. In general the header information facilitates and optimises decoding of messages and avoids using unnecessary power. The information in the tag class field indicates a class of tag into which the tag falls
10 from a plurality of tag classes, each tag class having predetermined peripheral capabilities and hence a tag message format with corresponding data fields. Optionally, the tag class field can convey additional tag information, such as tag type or model and, where relevant, mode of operation. In this embodiment the tag unique ID is a multi-byte value which is assigned before deployment, for example during manufacturing. The data field contains tag
15 data from the peripherals, which is not user definable as well as tag data which is user definable, as will be described in more detail below. The error checking information is used for packet verification and validation, and may be implemented for example as a 16-bit LRC calculated by linear addition of all relevant bytes. A skilled person will appreciate that the precise tag message packet structures defined herein are exemplary only and for example that
20 some fields are optional and certain "header" or "field" information could feasibly be placed elsewhere or omitted altogether in some embodiments.

Fig. 8A-8G shows a plurality of exemplary tag message packet formats, each message packet having a different structure corresponding to the tag class from which the message
25 originates.

With reference to Figure 8A, a first tag message packet (for tag class 1) has a header 702, tag class information 704, tag ID 708, and, optionally, error correction information 712. This tag message packet may be sent for example in situations where the tag is required only to provide tag identification under predetermined circumstances. An example is building access applications.

With reference to Fig. 8B, a further tag message packet (for tag class 2) has a header 702, tag class information field 704, a tag ID field 708, a data field 710 and error checking information 712. In this case the tag class information indicates that at a predetermined portion of the tag data field is used to report on "tag age" which is estimated by a counter that increments each time the tag transmits. Rather than being a true age based on time, this is in fact a measure of age in terms of the tag life-cycle which is limited in practice by the battery life.

15

With reference to Fig. 8C, a further tag message packet (for tag class 3) has a header 702, tag class information 704, a tag ID field 708, a data field 710, and error checking information 712. In this case the tag class information 704 indicates that at least a portion of the tag data field 710 is used to convey user defined data of some type. The application program is capable of decoding the user defined data.

20

With reference to Fig. 8D, a further tag message packet (for tag class 4) has a header 702, tag class information 704, a tag ID field 708, a data field 710, and error checking information 712. In this case the tag class information 704 indicates that at least a portion of the tag data field 710 is used to convey a user defined identity code from the tag.

25

With reference to Fig. 8E, a further tag message packet (for tag class 5) has a header 702, tag class information 704, a tag ID field 708, a data field 710, and error checking information 712. In this case the tag class information 704 indicates that predetermined portions of the tag data field 710 are used to convey predetermined peripheral data (P. DATA) and user defined data (USER DATA). The peripheral data may itself have user defined elements. For example this tag message packet might be employed to send data from a tag having a temperature sensor and a user defined identity code.

10 With reference to Fig. 8F, a further tag message packet (for tag class 6) has a header 702, tag class information 704, a tag ID field 708, a data field 710, and error checking information 712. In this case the tag class information 704 indicates that predetermined portions of the tag data field 710 are used to convey data from first and second peripherals (P₁ DATA and P₂ DATA). The peripheral data from either peripheral may itself have user defined elements. For example this tag class packet might be employed to send data from a tag having a temperature sensor and a GPS location sensor. An example of peripheral data having user defined elements is where a user has programmed the tag only to report temperature exceeding a predetermined temperature threshold. In this type of packet the tag class information may be supplemented with tag type information which indicates, for example, that the tag has two sensor functions and is operating in a mode supporting (e.g. temperature and GPS sensors). Either type of peripheral data, on both, may have user defined elements.

25 With reference to Fig. 8G, a further tag message packet (for tag class 7) has a header 702, tag class information 704, a tag ID field 708, a tag data field 710, and error checking

information 712. In this case the tag class information 704 indicates that predetermined portions of the tag data field 710 are used to convey data from first and second peripherals, and user definable data. For example this tag message packet might be employed to send data from a tag having a chemical sensor, tamper sensor and a user definable identification code. As before, the tag class field may be supplemented by tag type information which indicates, for example, that the tag has a two sensor function and is operating in a mode supporting a specific chemical sensor (say a gas sensor) and tamper sensor with a user definable tag ID code. Data from either or both peripherals may also have user defined elements.

10

With reference in particular to Fig. 9, which shows a schematic representation of a generalised message packet structure for further potential tag classes, it will be apparent that the tag message packet scheme used in embodiments of the present invention is capable of supporting a number of multi-peripheral tag designs by virtue of a plurality of predetermined tag message packets provided with one or more fields defining the tag class from which the message originates, and optionally also a tag type or mode within that class.

15

Fig. 10 illustrates by means of an exemplary process chart how tag data is conveyed from the tag to the application program in embodiments of the present invention.

20

At 1000, the tag microprocessor initiates a tag message send process. For example, this may be in response to a reader inquiry or it may be under a type of beaconing regime known in the RFID arts. At 1010, the microprocessor builds a message packet of a suitable type based on the tag class. In this example it is assumed that the tag message packet will adopt a format 1012 corresponding to a predetermined tag class from the number of possible tag classes (see Fig. 8) and extends to a total of packet length of 64 bytes. Relevant system

25

information 1014 and tag data 1016 (including peripheral data and user defined data as may be appropriate) is sourced from the tag memory and the message packet is constructed accordingly. The tag message packet is provided to the analogue transmission circuitry including the RF oscillator and the antenna and transmitted 1020 over the air interface 112 to
5 a reader 103.

At 1030 the reader receives the tag message packet and processes it as necessary to convert it from analogue to digital format. The microprocessor of the reader then builds a reader network response type packet (or a general reader network packet of similar
10 construction) 1032 and queues it in a reader buffer for transmission over the reader network to the application 120 of the control interface 100. For this building process the reader uses the appropriate reader network format message format 1032 (see Fig. 5) which in this embodiment incorporates the tag message packet 1034 in its entirety. At 1040, the reader network sends the reader network message packet to the application program in accordance
15 with the reader network backbone communication protocol.

Further it will be apparent that the described embodiment is useful in particular with tags having multiple sensors and the like, and which also permit user definable data to be programmed. The user definable data can be either independent of the peripheral function(s)
20 or for controlling one or more aspects of the peripheral sensing or reporting functions.

In summary embodiments provide, among other things a functionally rich and versatile tag-reader communications protocol, capable of scalable deployment to support a wide range of current and future applications. At the same time embodiments described here
25 achieve high data throughput and interoperability, whilst minimising power consumption.

Those skilled in the art will appreciate that while the foregoing has described what is considered to be the best mode and, where appropriate, other modes of performing the invention, the invention should not be limited to the specific configurations and methods
5 disclosed in this description of the preferred embodiment. Those skilled in the art will recognise that the invention has a broad range of applications in many different types of remote identification, data and sensor applications, and that the embodiments may take a wide range of modifications without departing from the inventive concept as defined in the appended claims. For example, the invention has applications in all manner of asset
10 management, personal management, supply chain management and process control applications in various fields of operation such as industrial, medical, military, home, office and other.

CLAIMS:

1. A method for signalling in an RFID network comprising active transponders and networked reader units deployed to receive communications from said transponders, the
5 method comprising:
employing amplitude shift keying to encode data based on transitions between a high and a low signal according to a scheme in which respective ones of a plurality of bit combinations of binary numbers are transmitted as different predetermined delays between signal transitions.
10
2. A method of signalling as in claim 1, wherein each said predetermined delay comprises a delay between consecutive high signal states.
3. A method of signalling as in any preceding claim, wherein each predetermined delay
15 indicates a two-bit combination of binary numbers.
4. A method of signalling as in any preceding claim, wherein the duration at a high signal state is less than or equal to the duration of the shortest predetermined delay between high signal states.
20
5. A method of signalling as in any preceding claim, wherein the duration of a high signal state is a value selected from one of the following ranges: 40 to 5 μ s; 30 to 10 μ s; and 25 to 15 μ s.

6. A method of signalling as in any preceding claim, wherein the duration of a high signal state is about 20 μ s.
7. A method of signalling as in any preceding claim, wherein the shortest predetermined delay between high signal states is greater than 20 μ s.
8. A method of signalling as in any preceding claim, wherein at least first and second of said predetermined delays differ from each other by about half the duration of the shortest interval.
9. A method of signalling as in any preceding claim, wherein first, second, third and fourth delays comprise different durations selected respectively from the ranges: 18 to 38 μ s; 32 to 52 μ s; 48 to 68 μ s and 62 to 82 μ s.
10. A method as in claim 9, wherein a first, second, third and fourth of said predetermined intervals are respectively about 28 μ s; 42 μ s; 58 μ s and 72 μ s.
11. A method as in any preceding claim, wherein a synchronisation signal is applied ahead of said data signal.
12. A method as in claim 11, wherein said synchronisation signal comprises a predetermined plurality of pulses.
13. A method of signalling as in claim 12, wherein one or more of said pulses comprises a high signal state for a period between 100 and 300 μ s.

14. A method of signalling as in claim 12, wherein intervals between pulses comprise a period of between 50 and 70 μ s.
- 5 15. An active tag for an RFID network comprising:
- transmission means employing amplitude shift keying means adapted to encode transmission data based on transitions between a high and a low signal according to a scheme in which respective ones of a plurality of bit combinations of binary numbers are transmitted as different predetermined delays between signal transitions.

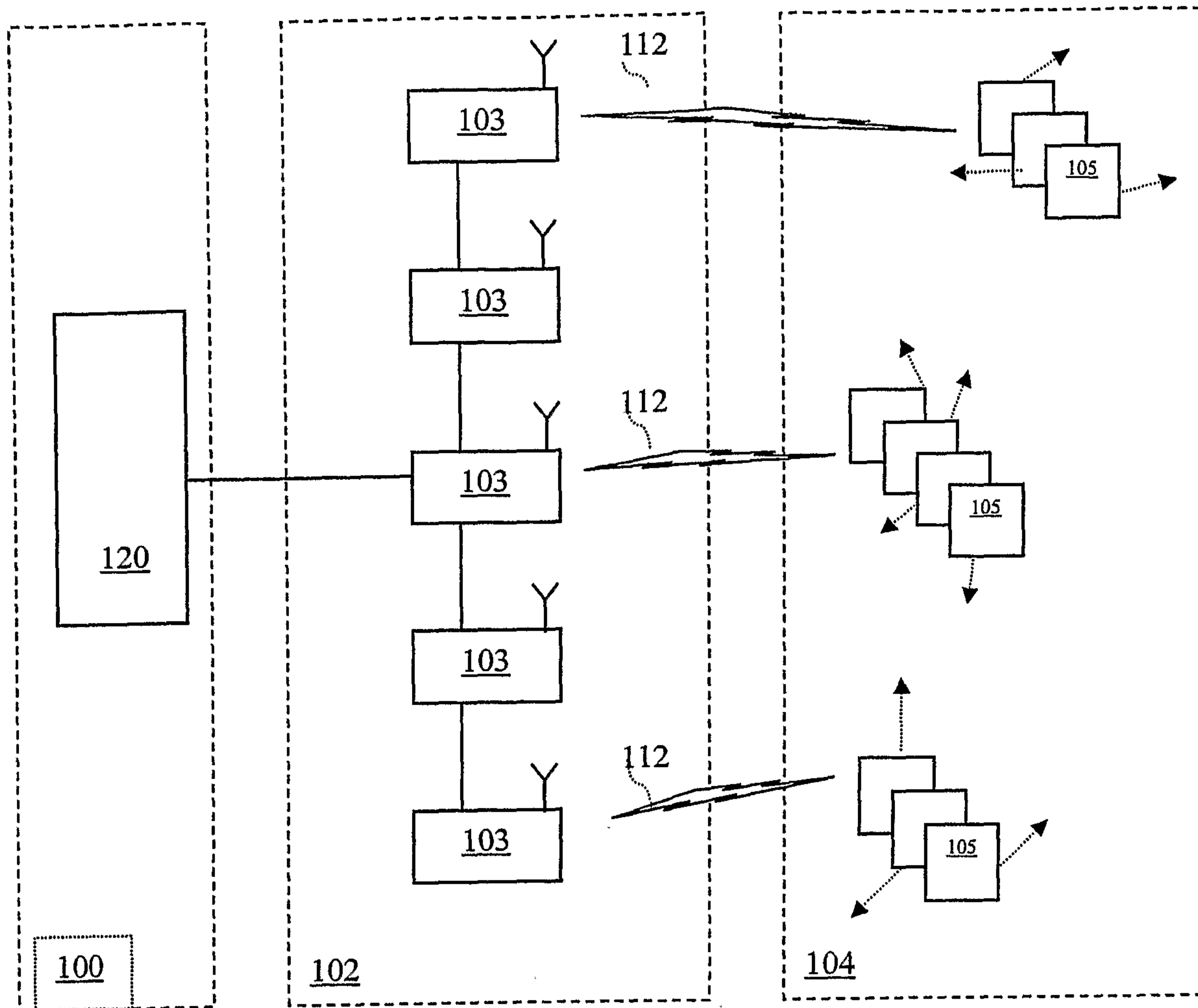

FIGURE 1

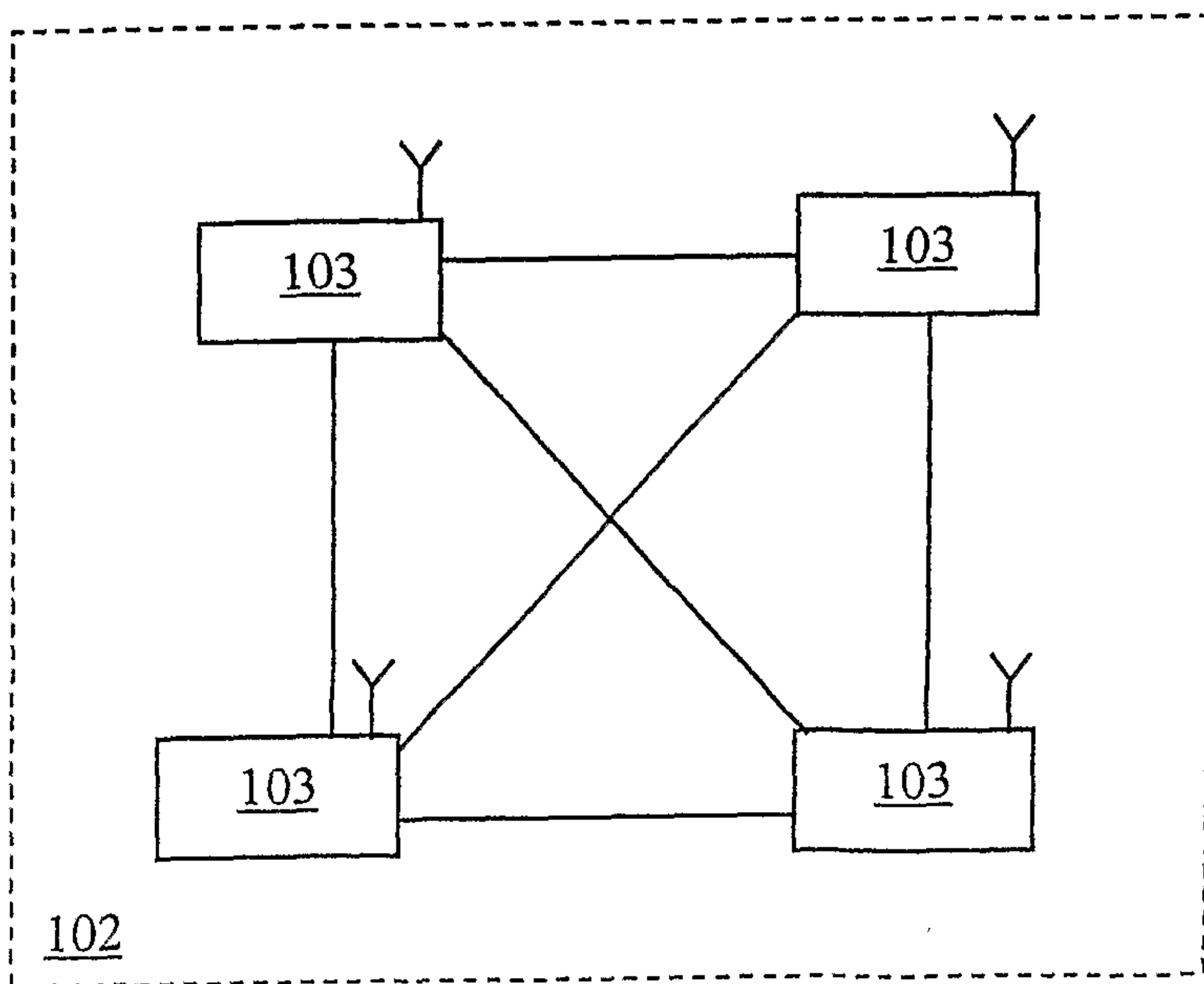

FIGURE 2

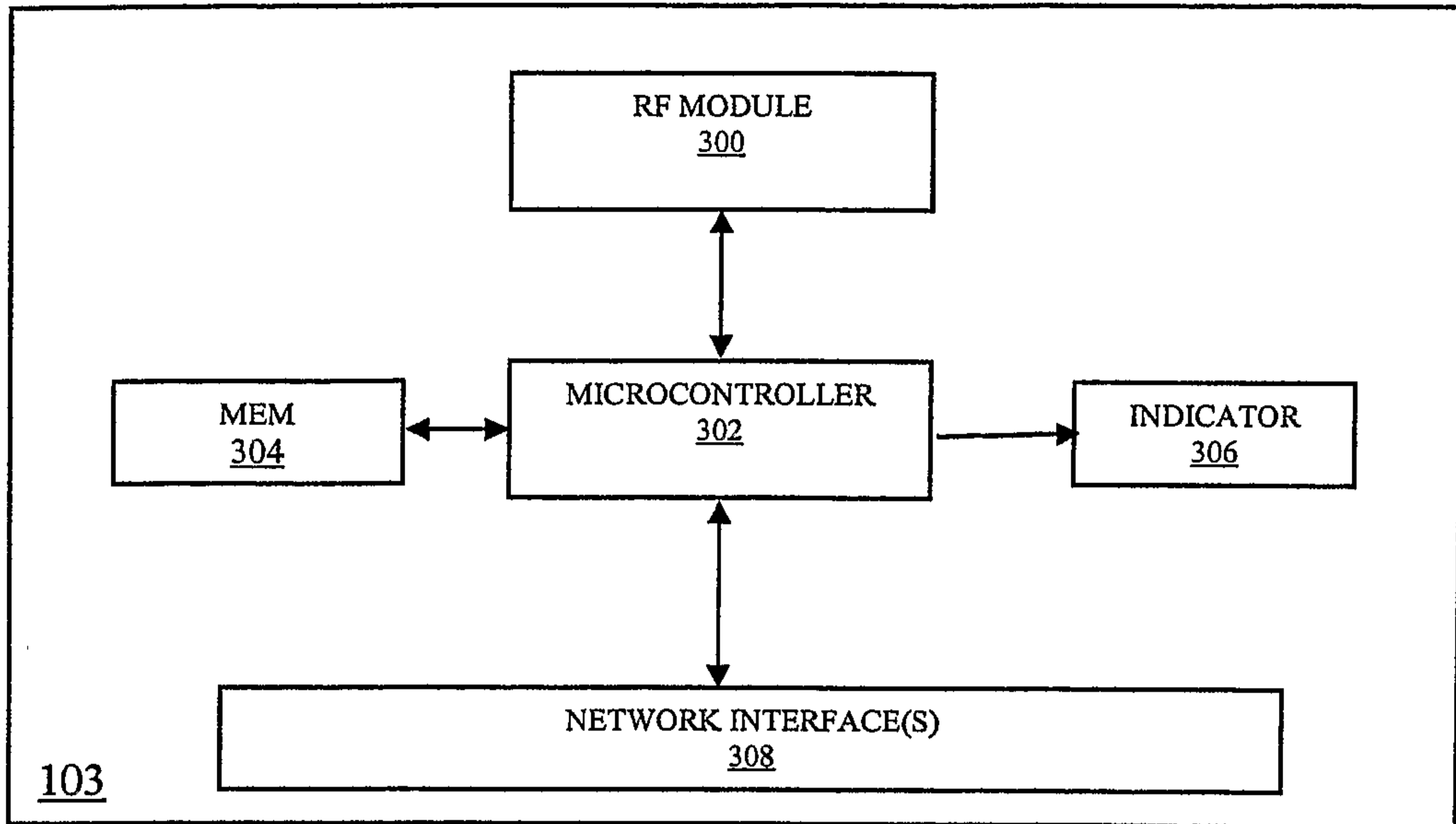

FIGURE 3

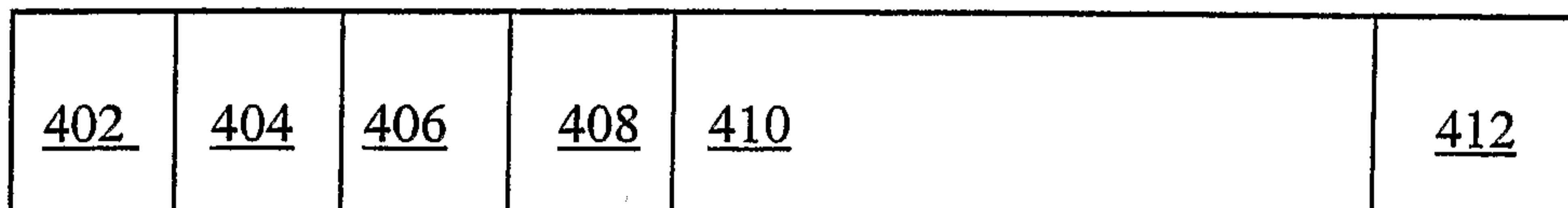

FIGURE 4

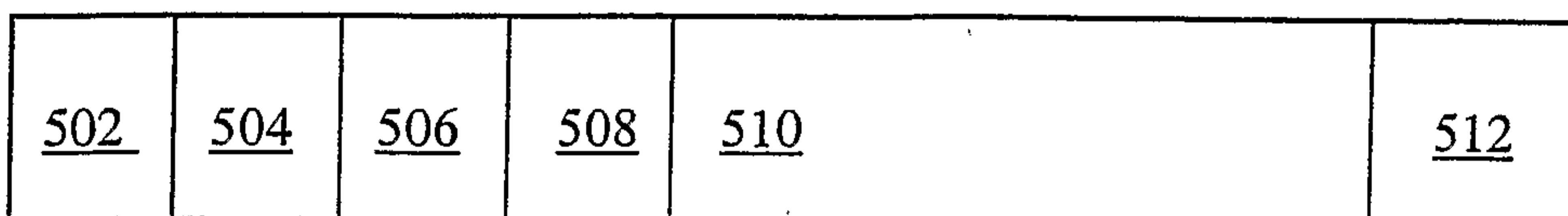

FIGURE 5

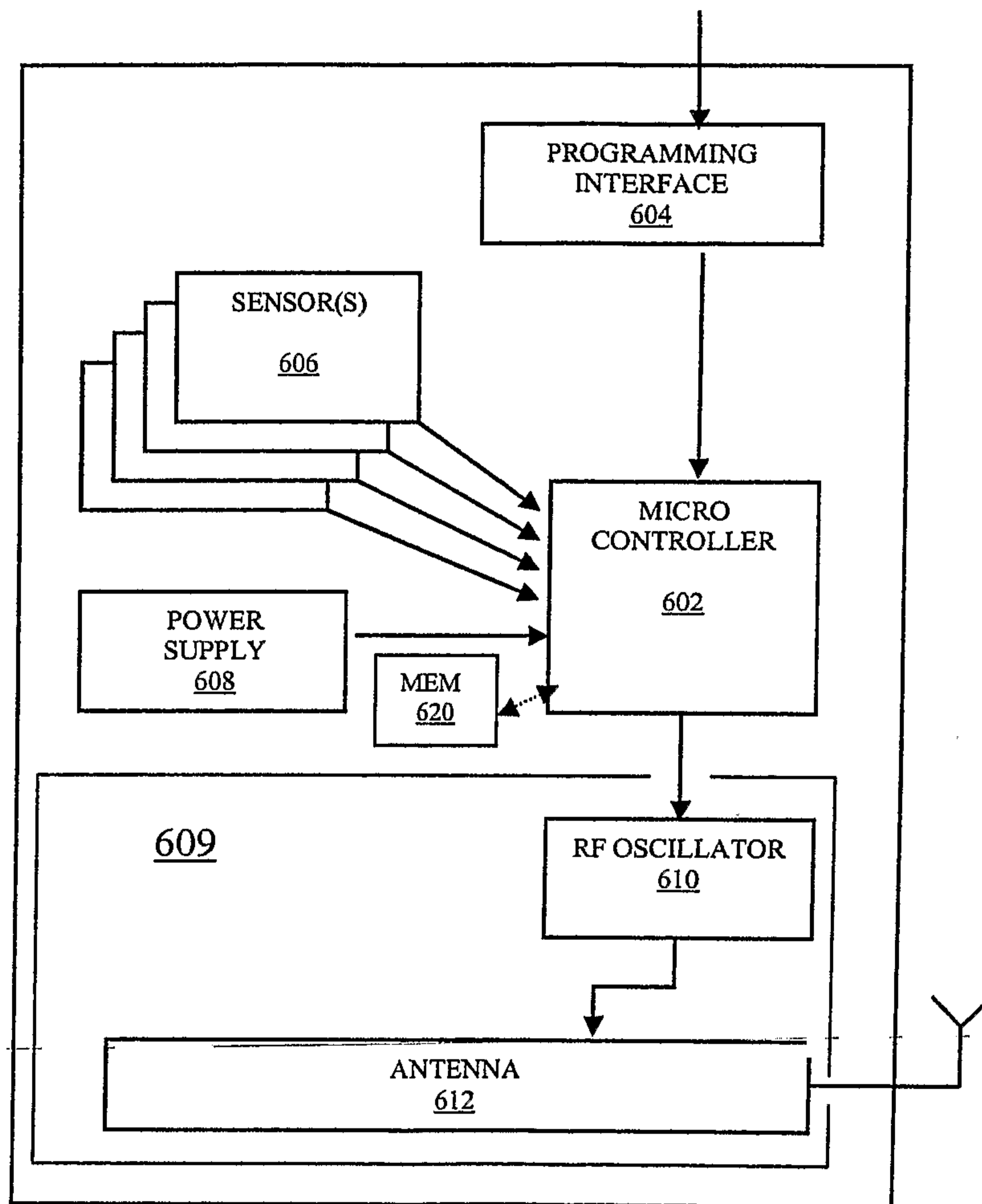

FIGURE 6

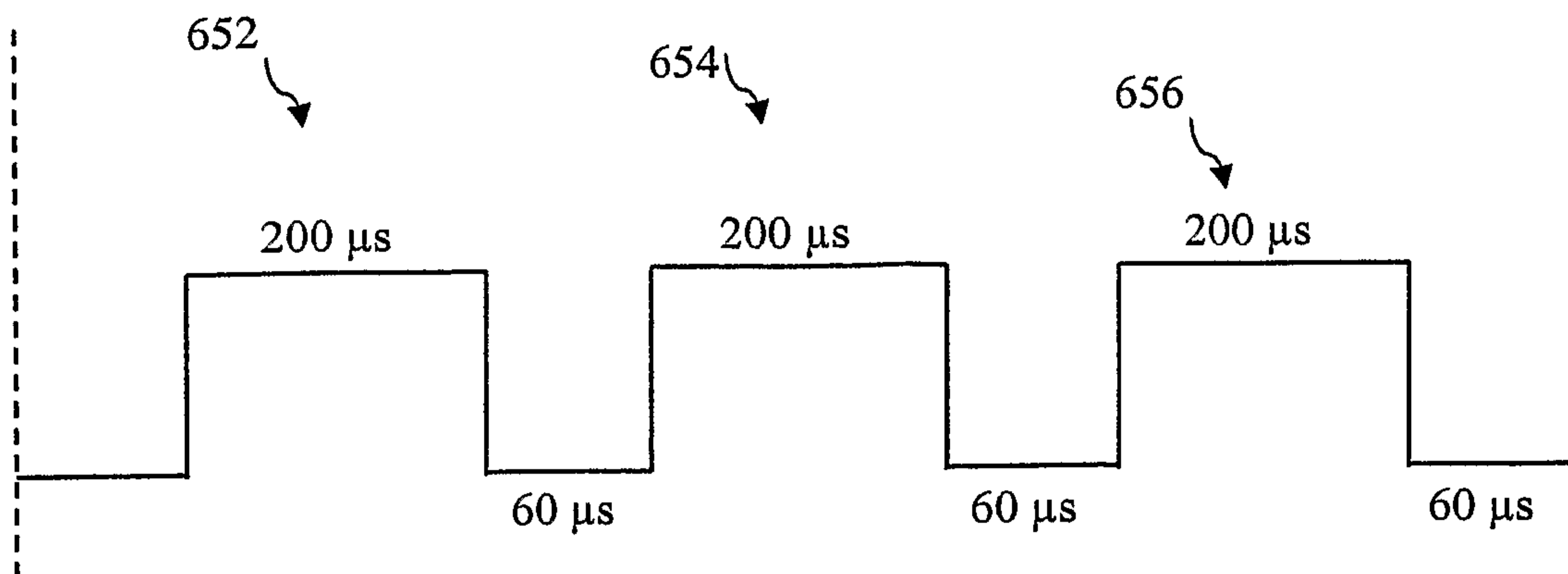

Fig. 6A

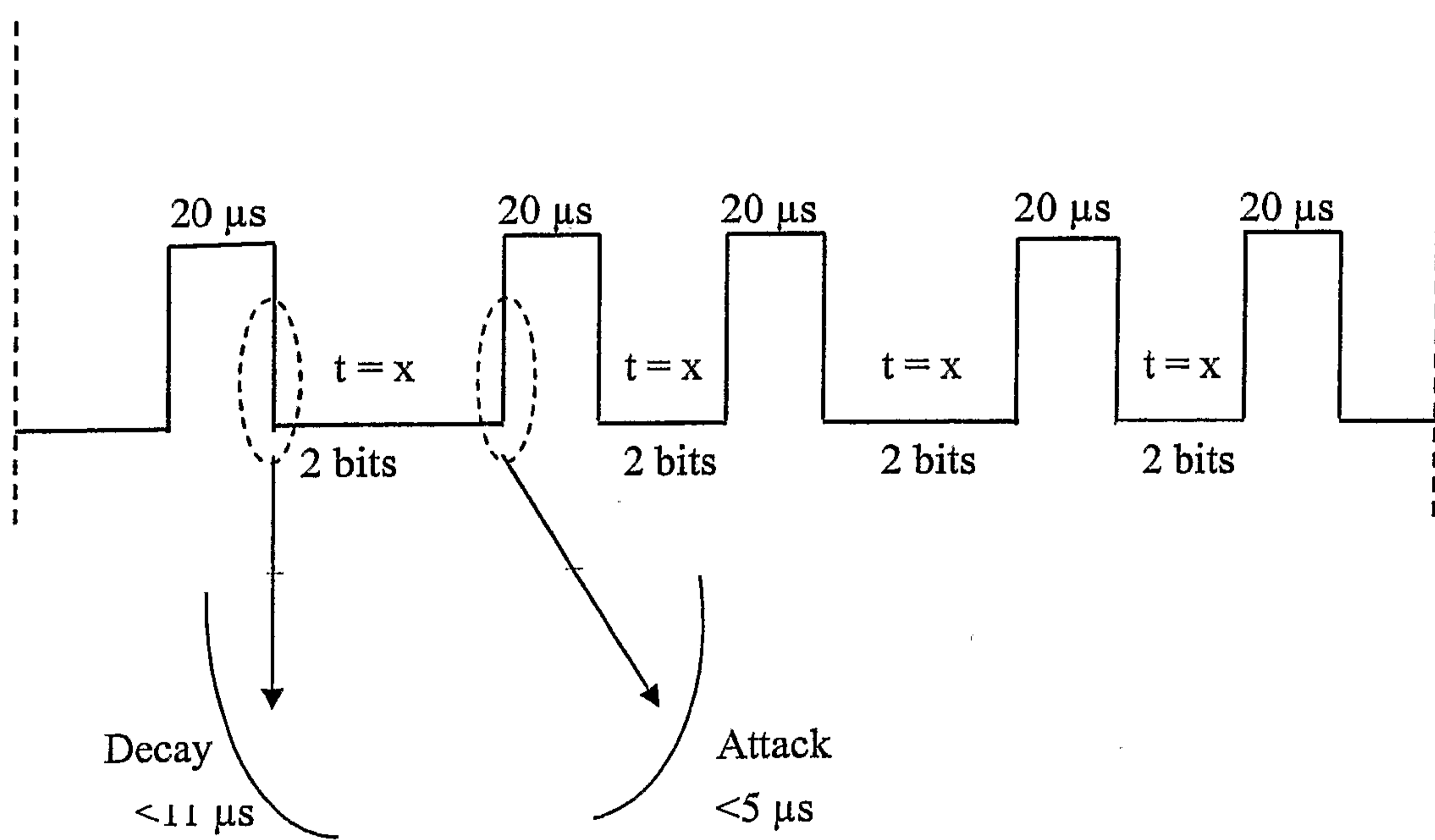

Fig. 6B

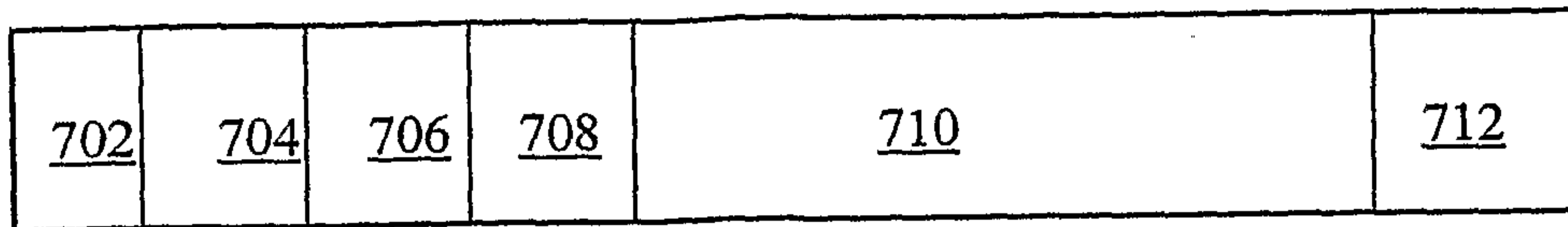

FIGURE 7

FIGURE 8A

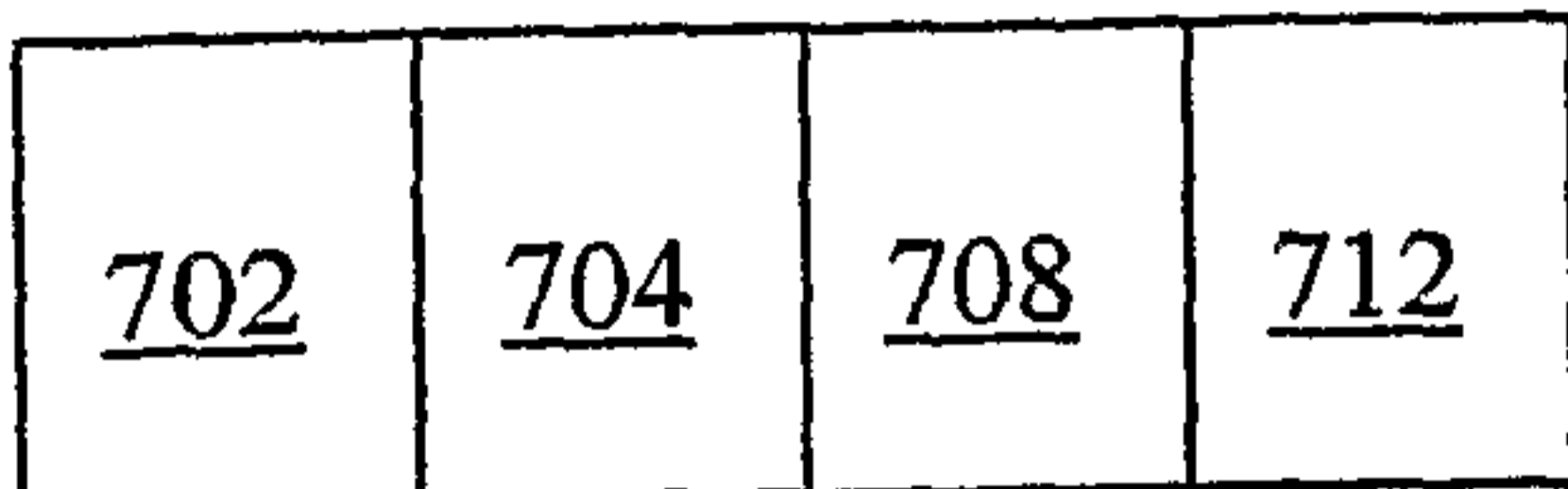

FIGURE 8B

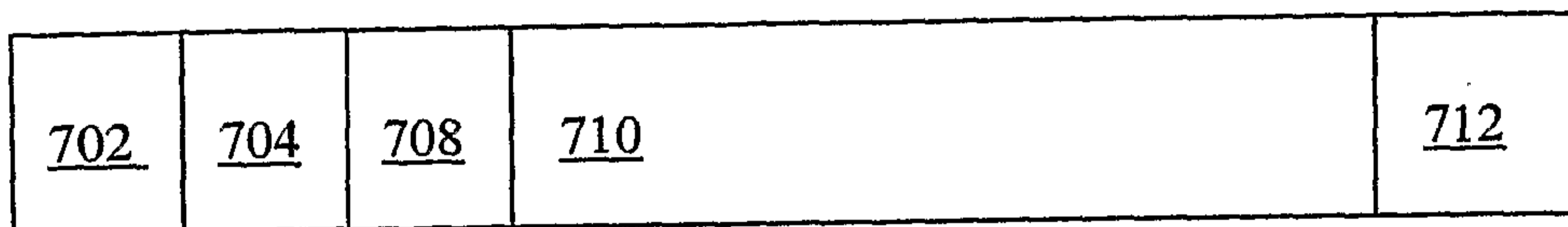

FIGURE 8C

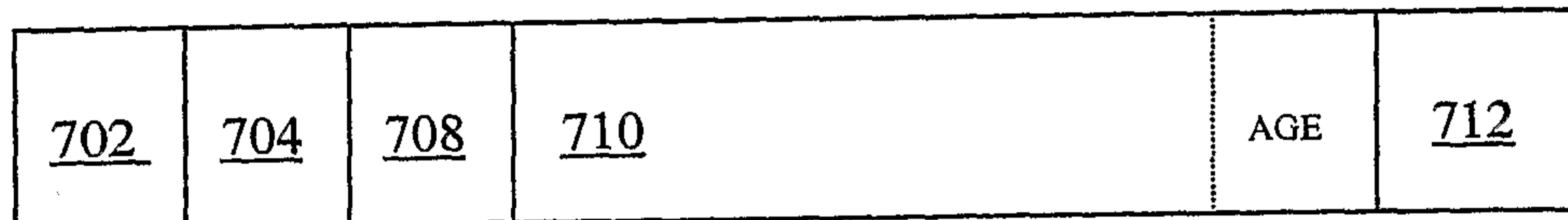

FIGURE 8D



FIGURE 8E

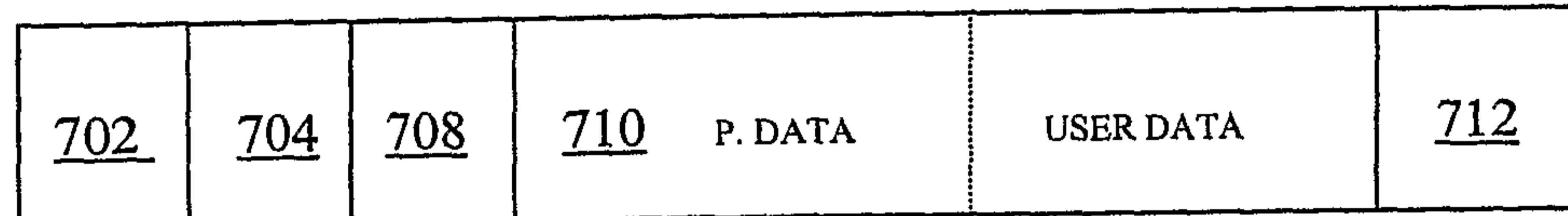

FIGURE 8F

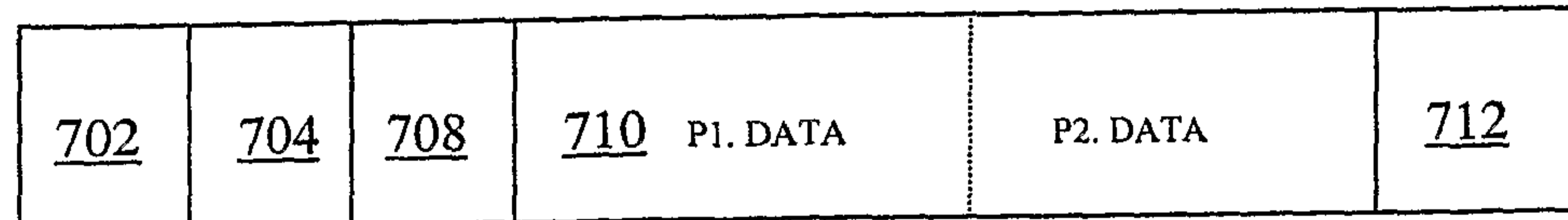

FIGURE 8G

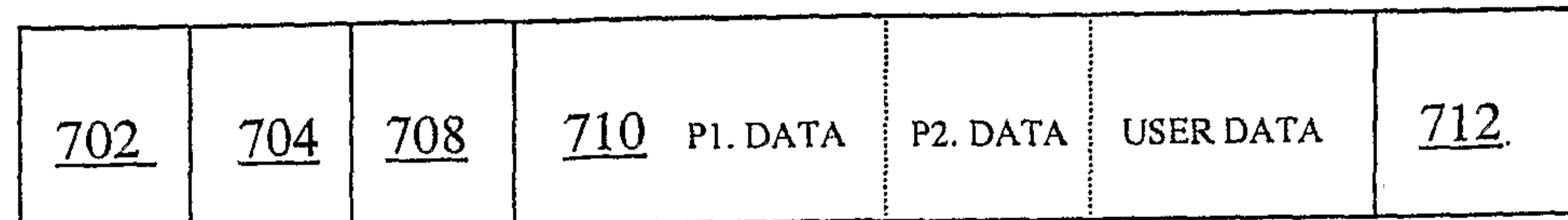
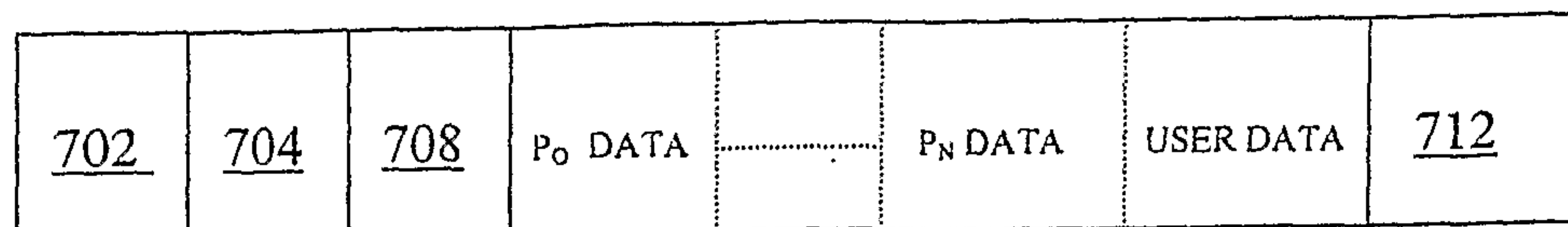

FIGURE 9



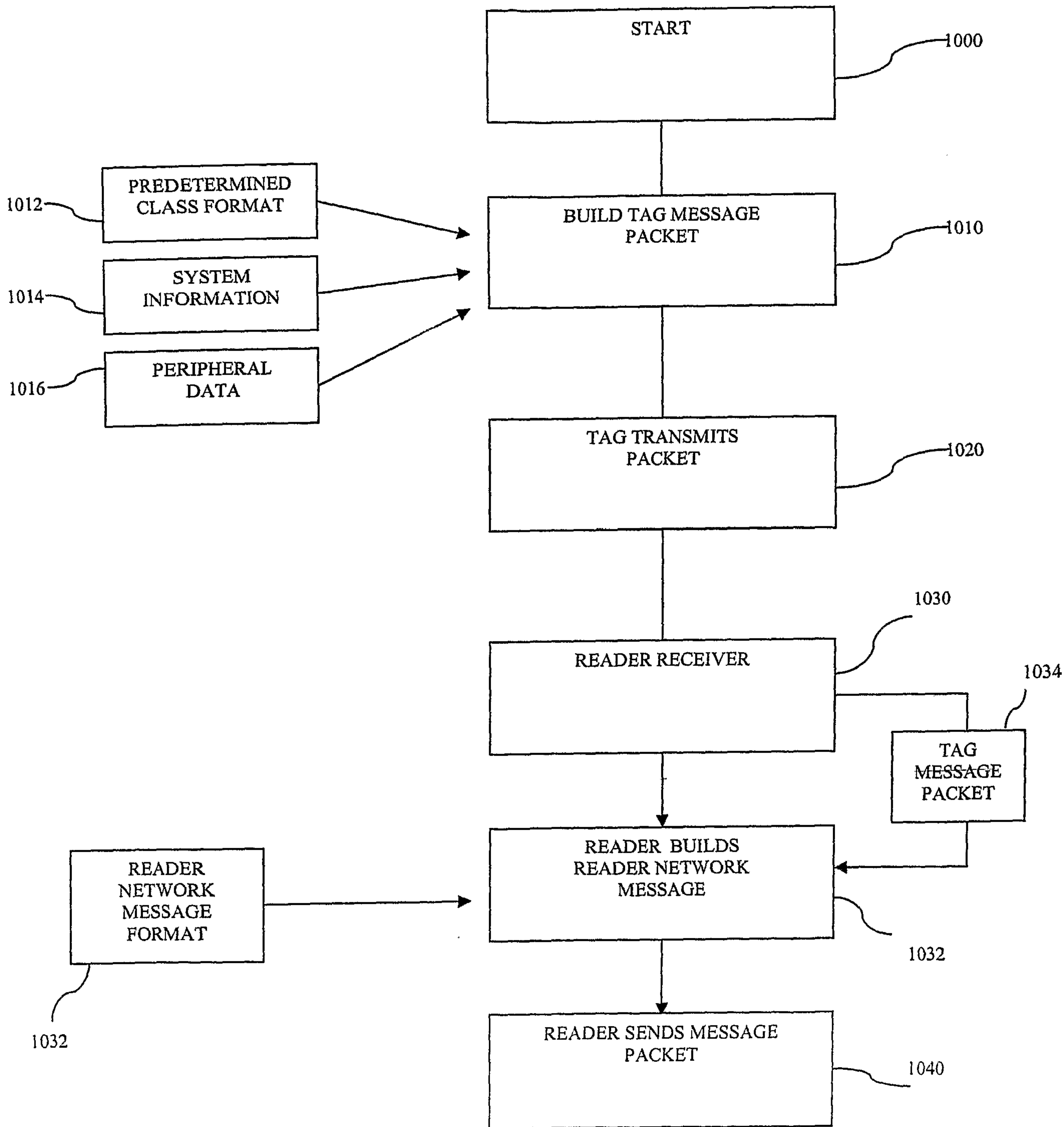

FIGURE 10

