

C. F. WILKINSON, L. S. ALLISON, P. RILEY &
 A. MOCHAMER.
 Mining-Drill.

No. 221,378.

Patented Nov. 4, 1879.

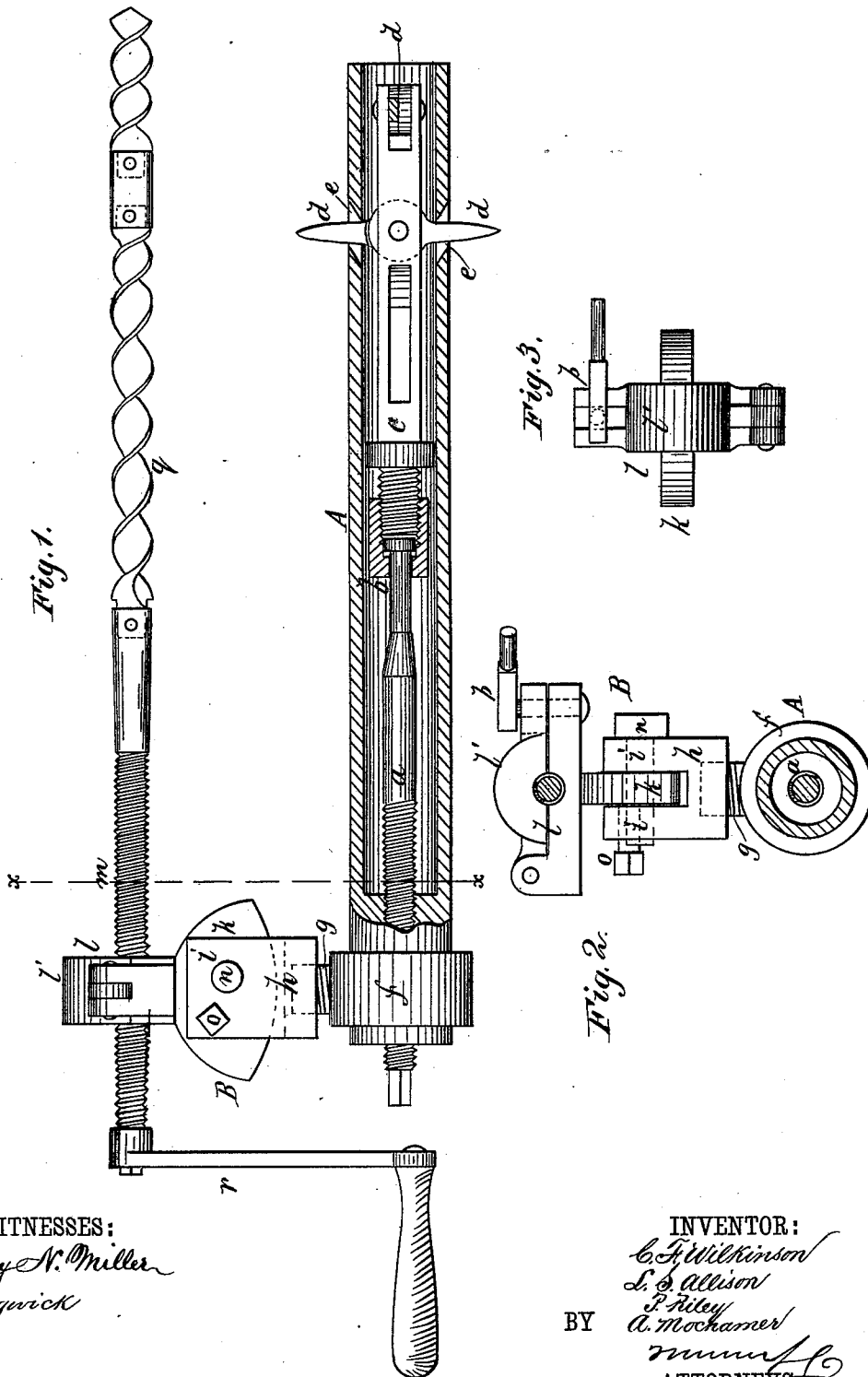

WITNESSES:
Henry N. Miller
C. Sedgwick

INVENTOR:
C. F. Wilkinson
L. S. Allison
P. Riley
A. Mochamer
 BY *[Signature]*
 ATTORNEYS.

UNITED STATES PATENT OFFICE.

CHARLES F. WILKINSON, L. SANDIDGE ALLISON, PETER RILEY, AND ARIO MOCHAMER, OF HAZLETON, PENNSYLVANIA.

IMPROVEMENT IN MINING-DRILLS.

Specification forming part of Letters Patent No. 221,378, dated November 4, 1879; application filed May 1, 1879.

To all whom it may concern:

Be it known that we, CHARLES F. WILKINSON, L. SANDIDGE ALLISON, PETER RILEY, and ARIO MOCHAMER, of Hazleton, in the county of Luzerne and State of Pennsylvania, have invented a new and Improved Mining-Drill, of which the following is a specification.

Our improvements relate to drilling apparatus for miners, and are especially adapted to coal-mining.

The invention consists in combining a tubular post with inclined apertures, a nut-carrying screw-rod, and a screw-socket having spurs pivoted to its head; also, in combining a collar on the post and a side screw on the collar with a drill-holder having a nut with lugs, a nut having tongue on cross-pin, a set-nut, and a screw, all as hereinafter described.

In the accompanying drawings, Figure 1 is a side elevation of the apparatus, the post being in section. Fig. 2 is a vertical cross-section on line *xx* of Fig. 1. Fig. 3 is a top view of the holding-nut for the screw which operates the drill.

Similar letters of reference indicate corresponding parts.

The post *A* consists of a tube of the desired length, having its outer end closed by a nut which carries the screw-rod *a*. On the inner end of screw *a* is a screw-socket, *b*, that is fitted to turn freely on *a*, and has attached to it the bar or head *c*, which carries the loosely-hung spurs *d*.

The spurs *d* are preferably four in number, and hung to project from the head *c*, and are adapted for passing through the inclined apertures *e* in post *A*, which apertures are shaped to catch the tapered ends of the spurs and cause them to project outward as the head *c* is moved forward by screw *a*. The end of screw *a*, projecting from the outer end of the post, is squared for the application of a wrench or crank-handle whereby the screw is to be turned.

This portion of the apparatus is used by drilling a hole in the coal of a size to receive the post loosely, which is to be inserted with the spurs withdrawn. After insertion of the

post the operation of the screw will move head *c* forward, and the spurs will be driven into the coal at the sides of the tube, thereby acting as anchors to hold the post securely, and preventing it from turning or being forced out by the drill.

Upon the outer end of post *A* is attached a collar, *f*, which has a screw, *g*, projecting from it at one side, and by this screw is attached the drill-holder *B*. This holder *B* consists of the nut *h*, working on screw *g*, and formed with lugs *i i*, between which is attached the tongue *k* of the nut *l*, that carries the screw *m*.

The tongue *k* is hung on the cross-pin *n*, on which the nut *l* swings, and it is clamped in the desired position by a set-nut, *o*, passing through one lug, *i*.

For convenience in applying the screw *m* to nut *l*, the latter is made in two parts, or as a box, having the upper part, *v*, hung by a pin at one side, and when in place the part *v* is held by a locking-arm, *p*, or by any other suitable means.

The screw *m* carries at its inner end the drills *q*, and is fitted at its outer end with a handle, *r*, for operation of the drills.

It will be seen that by the above-described construction the screw *m* is universally jointed, or nearly so, and with the parts in the relative position shown the drill can be swung horizontally and vertically to drill the hole at the desired angle.

The post may, however, be inserted with the drill at either side, or beneath, instead of at the upper side, as shown.

This construction furnishes a very light, durable, and effective drilling apparatus. The parts are simple, and not liable to get out of order.

The apparatus is easily carried in the hand, can be quickly applied and as readily removed, and is convenient for use. The features result in a saving of time, labor, expense, and room occupied by the drills.

Having thus described our invention, we claim as new and desire to secure by Letters Patent—

1. The combination of the tubular post A, having inclined apertures *e*, the nut-carrying screw-rod *a*, and the screw-socket *b*, having spurs *d* pivoted to its head *c*, as shown and described.

2. In a mining-drill, the combination, with the hollow post A, of the screw *a*, head *c*, and loosely-hung spurs *d*, substantially as and for the purposes set forth.

3. The post A, having collar *f*, with side screw, *g*, in combination with a drill-holder, B,

having nut *h*, with lugs *i i*, the nut *l*, having tongue *k* on a cross-pin, *n*, the set-nut *o*, and the screw *m*, as shown and described.

CHARLES F. WILKINSON.
L. SANDIDGE ALLISON.
PETER RILEY.
ARIO MOCHAMER.

Witnesses:

C. W. KLINE,
J. D. HAYES.