



(51) International Patent Classification:  
F04D 27/00 (2006.01) G01F 1/36 (2006.01)  
F04D 29/42 (2006.01)

(21) International Application Number:  
PCT/US2011/000498

(22) International Filing Date:  
18 March 2011 (18.03.2011)

(25) Filing Language: English

(26) Publication Language: English

(30) Priority Data:  
12/798,684 9 April 2010 (09.04.2010) US

(71) Applicant (for all designated States except US): **TRANE INTERNATIONAL INC.** [US/US]; One Centennial Avenue, Piscataway, NJ 10019 (US).

(72) Inventors: **SMILEY, William, A.**; N1649 Meadow Ridge Road, La Crosse, WI 54601 (US). **REYNOLDS, Brian, L.**; N4657 Maple Lane, Onalaska, WI 54650 (US).

(74) Agent: **O'DRISCOLL, William**; Trane Intellectual Property Department, 3600 Pammel Creek Road, La Crosse, WI 54601 (US).

(81) Designated States (unless otherwise indicated, for every kind of national protection available): AE, AG, AL, AM,

AO, AT, AU, AZ, BA, BB, BG, BH, BR, BW, BY, BZ, CA, CH, CL, CN, CO, CR, CU, CZ, DE, DK, DM, DO, DZ, EC, EE, EG, ES, FI, GB, GD, GE, GH, GM, GT, HN, HR, HU, ID, IL, IN, IS, JP, KE, KG, KM, KN, KP, KR, KZ, LA, LC, LK, LR, LS, LT, LU, LY, MA, MD, ME, MG, MK, MN, MW, MX, MY, MZ, NA, NG, NI, NO, NZ, OM, PE, PG, PH, PL, PT, RO, RS, RU, SC, SD, SE, SG, SK, SL, SM, ST, SV, SY, TH, TJ, TM, TN, TR, TT, TZ, UA, UG, US, UZ, VC, VN, ZA, ZM, ZW.

(84) Designated States (unless otherwise indicated, for every kind of regional protection available): ARIPO (BW, GH, GM, KE, LR, LS, MW, MZ, NA, SD, SL, SZ, TZ, UG, ZM, ZW), Eurasian (AM, AZ, BY, KG, KZ, MD, RU, TJ, TM), European (AL, AT, BE, BG, CH, CY, CZ, DE, DK, EE, ES, FI, FR, GB, GR, HR, HU, IE, IS, IT, LT, LU, LV, MC, MK, MT, NL, NO, PL, PT, RO, RS, SE, SI, SK, SM, TR), OAPI (BF, BJ, CF, CG, CI, CM, GA, GN, GQ, GW, ML, MR, NE, SN, TD, TG).

**Declarations under Rule 4.17:**

— as to the applicant's entitlement to claim the priority of the earlier application (Rule 4.17(iii))

**Published:**

— with international search report (Art. 21(3))



WO 2011/126540 A1

(54) Title: FC FAN FLOW MEASUREMENT SYSTEM

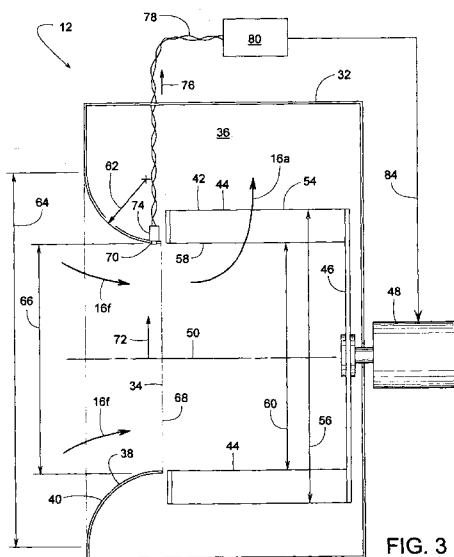

(57) Abstract: An airflow volume sensing means for determining the flow rate through a fan includes a curved inlet cone with a pressure sensor at the minimum diameter of the cone, wherein the flow volume sensing means is particularly suited for FC centrifugal fans (centrifugal fans with forward curved fan blades). With an FC fan, the minimum diameter of the inlet cone's interior surface is adjacent the fan wheel, and the static pressure there is at a minimum value. A predetermined relationship between the static gage pressure at that point and the volume flow rate through the fan is applied regardless of variables such as fan speed, fan housing geometry, supply air duct configurations, return air duct configurations, location of various heat exchangers or filters, etc. In some embodiments, a single pressure sensor senses an average of a plurality of pressure taps, wherein each tap is at approximately the same minimum pressure.

## **TITLE**

### **FC Fan Flow Measurement System**

## **BACKGROUND OF THE INVENTION**

**[0001]** 1. Field of the Invention

**[0002]** The subject invention generally pertains to centrifugal fans and more specifically to flow measuring systems for such fans.

**[0003]** 2. Description of Related Art

**[0004]** The volume of air flowing through a fan can be difficult to determine because the air velocity usually varies depending on the location of the air streams within the fan or within the ducts leading to or from the fan. In some cases, a series of pressure taps distributed across the flow path provides a means for integrating the air's velocity profile, from which the total airflow volume can be determined. Inserting such pressure taps across the flow path, however, can disrupt and restrict the flow.

**[0005]** In other cases, the air is directed through a certain flow restriction for which there is a known relationship between the volume airflow rate and the resulting pressure drop across the restriction. Such an approach, however, can present an undesirable flow restriction and requires multiple pressure taps to sense the pressure drop across the restriction.

### **Summary of the Invention**

**[0006]** It is an object of some embodiments to determine the volume airflow rate through a centrifugal fan by using as few as just one pressure gage and without creating an undesirable pressure drop or flow obstruction.

**[0007]** Another object of some embodiments is to use a single pressure sensor for sensing an average of a plurality of pressure taps, wherein each tap is at approximately the same subatmospheric pressure.

**[0008]** Another object of some embodiments is to determine the volume airflow rate through a centrifugal fan by sensing the minimum static pressure of the air entering the fan, whereby the reading is more accurate due to a relatively large or maximum pressure differential between the sensed minimum subatmospheric static pressure and the ambient barometric pressure.

**[0009]** Another object of some embodiments is to add a pressure sensor to a curved inlet cone that can be applied to a centrifugal fan for determining the air volume throughput regardless of changeable or unknown variables, examples of which include, but are not limited to, fan speed, fan housing geometry, fan blade length (actual or effective), discharge airflow resistance, supply air duct configurations, return air duct configurations, size and location of various heat exchangers or filters, etc.

**[0010]** Another object of some embodiments is to provide a simple means for determining the volume airflow rate through a centrifugal fan, wherein the means is particularly suited for fans with forward curved fan blades (FC type centrifugal fans).

**[0011]** Another object of some embodiments is to shelter a static pressure receiver within a discharge air chamber of a centrifugal fan, thereby protecting the static pressure receiver from damage while providing a neat appearance.

**[0012]** In some embodiments, the present invention provides a fan system for drawing suction air and discharging discharge air. The fan system comprising a fan housing providing a suction inlet opening for receiving the suction air and defining a discharge air chamber within the fan housing for the discharge air. The fans system also includes a centrifugal fan wheel disposed within the fan housing between the suction inlet opening and the discharge air chamber and being rotatable to force air from the suction inlet opening to the discharge air chamber. A curved inlet cone encircles the suction inlet opening. The curved inlet cone includes a minor diameter and a major diameter. The minor diameter is in proximity with the centrifugal fan wheel and is downstream of the major diameter. A static pressure receiver disposed within the discharge air chamber is connected in fluid communication with the suction air flowing through the curved inlet

cone. A pressure sensor connected in fluid communication with the static pressure receiver is responsive to a static gage pressure of the suction air to provide a pressure signal indicative of the static gage pressure of the suction air at the minor diameter.

**[0013]** In some embodiments, the present invention provides a fan system for drawing suction air and discharging discharge air. The fan system comprises a fan housing providing a suction inlet opening for receiving the suction air and defining a discharge air chamber within the fan housing for the discharge air. A centrifugal fan wheel is disposed within the fan housing between the suction inlet opening and the discharge air chamber and is rotatable to force air from the suction inlet opening to the discharge air chamber. A curved inlet cone encircles the suction inlet opening. The curved inlet cone includes a minor diameter and a major diameter. The minor diameter is in proximity with the centrifugal fan wheel and is downstream of the major diameter. The inlet cone decreases in diameter continuously from the major diameter to the minor diameter. The inlet cone terminates at an inlet edge at the minor diameter. A static pressure receiver in proximity with the inlet edge is connected in fluid communication with the suction air flowing through the curved inlet cone. A pressure sensor connected in fluid communication with the static pressure receiver is responsive to a static gage pressure of the suction air to provide a pressure signal indicative of the static gage pressure of the suction air, wherein the suction air is at a minimum static gage pressure where the static pressure receiver is connected in fluid communication with the suction air flowing through the curved inlet cone.

**[0014]** In some embodiments, the present invention provides a fan system method using a centrifugal fan wheel rotating within a fan housing for drawing suction air and discharging discharge air. The method comprises rotating a centrifugal fan wheel within a fan housing, wherein the fan housing defines a suction inlet opening for receiving suction air and defines a discharge air chamber for the discharge air. The method includes conveying the discharge air as supply air from the discharge air chamber to a comfort zone. The method includes circulating the supply air through the comfort zone to

create return air. The method includes conveying from the comfort zone at least some of the return air to the suction inlet opening of the fan housing. While conveying at least some of the return air to the suction inlet opening, the method includes conveying the suction air through a curved inlet cone that leads to the suction inlet opening, wherein the suction air includes at least some of the return air, the curved inlet cone includes a minor diameter and a major diameter, and the minor diameter is in proximity with the centrifugal fan wheel and is downstream of the major diameter. The method includes sensing, at an inner surface of the curved inlet cone at the minor diameter, a static gage pressure of the suction air. The method includes determining a total volume flow rate of the suction air flowing through the curved inlet cone based on the static gage pressure of the suction air at the inner surface at the minor diameter.

#### **Brief Description of the Drawings**

- [0015] Figure 1 is a schematic diagram of one example fan system.
- [0016] Figure 2 is a cutaway side view of an example fan used in the fan system of Figure 1.
- [0017] Figure 3 is a cross-sectional view taken along line 3-3 of Figure 2.
- [0018] Figure 4 is a cutaway side view similar to Figure 2 but showing another example fan.
- [0019] Figure 5 is a cross-sectional view similar to Figure 3 but showing the fan with an alternate means for sensing the static pressure.
- [0020] Figure 6 is a cross-sectional view taken along line 6-6 of Figure 5.
- [0021] Figure 7 is a cross-sectional view similar to Figure 5 but showing an alternate static pressure receiver.

### **Description of the Preferred Embodiment**

[0022] Figure 1 schematically illustrates one example of a fan system 10 with a centrifugal fan 12 with additional views of fan 12 being shown in Figures 2 and 3. A novel means for determining the total volume airflow rate through fan 12 is used, in some cases, to help ensure that fan 12 delivers the proper amount of conditioned air and/or fresh outside air to a plurality of comfort zones 14, such as rooms or other designated areas of a building. Examples of conditioned air include, but are not limited to, air that has been heated, cooled, filtered, humidified, dehumidified, and various combinations thereof.

[0023] In the illustrated example, fan 12 discharges a current of discharge air 16a that is known as supply air 16b as a supply air duct 18 conveys the air to comfort zones 14. In this particular example, a heat exchanger 20 heats, cools, or otherwise conditions the current of air moved by fan 12. To meet the individual conditioned-air demands of zones 14, a plurality of adjustable VAV valves 22 (variable air volume valves) provide variable flow restrictions for regulating the amount of air delivered to each zone 14. In some embodiments, each zone 14 has a thermostat 24 that controls its respective VAV valve 22. After flowing through comfort zones 14, supply air 16b becomes return air 16c, which flows to a return air duct 26 and/or flows out through an exhaust air damper 28, with exhausted air 16d being forced outside by a fan 30. The portion of return air 16c that is not exhausted mixes with fresh incoming outdoor air 16e to create suction air 16f that feeds fan 12.

[0024] Fan 12 includes a fan housing 32 with a suction inlet opening 34 through which suction air 16f enters fan 12. In this example, housing 32 is a scroll shell with a discharge air chamber 36 for discharge air 16a, which exits housing 32 through a discharge opening 33. Housing 32 also includes a curved inlet cone 38 encircling inlet opening 34. Inlet cone 38 has a curved inner surface 40 that smoothly guides suction air 16f into housing 32.

**[0025]** To force the air from inlet 34 to discharge chamber 36, fan 12 has a centrifugal fan wheel 42 that rotates within housing 32. Fan wheel 42 comprises a plurality of fan blades 44 attached to a fan disc 46. A motor 48 coupled to fan disc 46 rotates fan wheel 42 about an axis 50 in the direction indicated by arrow 52. In this example, fan blades 44 are referred to as FC blades (forward-curved blades) because the blades lean forward with respect to the fan wheel's direction of rotation 52. Each blade 44 includes a trailing edge 54 at an outer diameter 56 of fan wheel 42 and a leading edge 58 at an inner diameter 60 of wheel 42, wherein leading edge 58 is upstream of trailing edge 54 with respect to airflow across fan blade 44.

**[0026]** In the example where fan blades 44 are curved forward, the ideal curvature of the inlet cone's inner surface 40 creates an effective radius 62 that in some examples is a true radius. In other examples, however, the curvature of inner surface 40 is parabolic, hyperbolic or otherwise deviates from a perfect circular segment having a perfect radius.

**[0027]** Moreover, in cases where fan blades 44 are curved forward, the ideal inlet cone decreases in diameter continuously from a maximum major diameter 64 to a minor diameter 66. At minor diameter 66, inlet cone 38 terminates at an inlet edge 68 that is in proximity with fan wheel 42. In this case, the term, "proximity," means inlet edge 68 is positioned sufficiently close to fan wheel 42 to create appreciable airflow resistance to leakage between edge 68 and fan wheel 42.

**[0028]** Blades 44 being curved forward in combination with inlet cone 38 being smoothly curved and terminating at its minor diameter 66 in proximity with fan wheel 42 provides a surprising and unexpected opportunity for measuring total airflow volume through fan 12. Although the suction air's velocity and thus its static pressure varies over a cross-sectional area of suction inlet opening 34, it has been discovered that the total airflow volume can be determined by sensing the static pressure (gage pressure) at a single-point tap location 70 on inlet cone 38 at minor diameter 66. It turns out that the total airflow volume through inlet 34 and fan 12 is approximately proportional to an exponential function (e.g., square-root) of the static gage pressure at point 70. This method makes it unnecessary to sense a plurality of static pressure readings to determine the actual airflow velocity profile over a cross-sectional area of inlet 34.

[0029] With total airflow volume (CFM) being proportional to an exponential of the static gage pressure (SGP), their relationship can be expressed as,  $CFM = (k)(SGP)^x$ . The term, "k," is a predetermined constant chosen to fit a fan's particular curved inlet cone. The term, "x" is an exponent that approximately equals 0.5 when inlet cone 38 is curved with an effective radius 62 that creates an airflow velocity profile that, through a cross-sectional area of inlet opening 34, varies approximately inversely proportionally to radial distance 72 from axis 50. With this relationship for a given curved inlet cone, a fan's throughput can be determined even as other variables change, such as fan speed, fan housing geometry, fan blade length (actual or effective), discharge airflow resistance, supply air duct configurations, return air duct configurations, size and location of various heat exchangers or filters, etc.

[0030] In the example shown in Figures 1 – 3, a single pressure sensor 74 is attached to inlet cone 38 to sense the static gage pressure at point 70. Sensor 74, in some examples, is a differential pressure gage that determines the static gage pressure at point 70 by measuring the difference between the absolute static pressure at point 70 and the ambient barometric air pressure outside of fan housing 32. A pressure signal 76 indicative of the static gage pressure is conveyed along wires 78 to a controller 80 that uses the information for one or more various reasons, examples of which include, but are not limited to, for controlling the speed of motor 48 to achieve a desired airflow rate, for controlling fan 30 or exhaust damper 28, for controlling the operation of heat exchanger 20, for controlling an incoming outdoor air damper 82, and for simply monitoring the flow rate through fan 12. In some examples, controlling motor 48, fan 30, exhaust damper 28, heat exchanger 20, outdoor air damper 82 is accomplished via output signals 84, 86, 88, 90 and 92, respectively. In some examples, output signal 84 for adjusting the speed of fan motor 48 varies in response to controller 80 receiving valve position signals 94 and 96 from VAV valves 22, wherein controller 80 adjusts the speed of fan motor 48 to provide a desired volume of supply air 16b that is appropriate for the degree to which VAV valves 22 are open.

[0031] It should be appreciated that system 10 of Figure 1 is just one of many possible example systems to which the present airflow measuring system can be applied. Also, fan housing 32 does not necessarily have to be of a scroll design. Figure 4, instance, shows fan wheel 42, pressure sensor 74 and curved inlet cone 38 being used with a plenum fan 98 having a box-like fan housing 100 with a side discharge opening 102.

[0032] Referring to Figures 5 and 6, although a single-point static pressure measurement will suffice in some applications, a more significant reading might be acquired by sensing the average pressure at a plurality of points 104 circumferentially distributed around a curved inlet cone 38' in proximity with inlet edge 68. In this case, the expression, "in proximity," means that points 104 are sufficiently close to inlet edge 68 that the static pressure at points 104 is substantially at a minimum as compared to all other points along inlet cone 38'.

[0033] In this example, a fan 106 includes a static pressure receiver 108 disposed within discharge chamber 36, wherein static pressure receiver 108 is connected in fluid communication with suction air 16f at points 104. The expression, "static pressure receiver," refers to any structure, conduit or feature for connecting a pressure transducer in fluid communication with suction air flowing through a curved inlet cone of a fan. In the example of Figures 1 – 3, the static pressure receiver and the pressure transducer are incorporated within pressure sensor 74 itself. In the example of Figures 5 and 6, static pressure receiver 108 further comprises a circular manifold 110 or tube with T-connectors 112 at each point 104. A tube 114 connects static gage pressure sensor 74 to a T-connector 116 that places pressure sensor 74 in fluid communication with manifold 110 and points 104.

[0034] In a similar example, shown in Figure 7, manifold 110 is replaced by a circular channel 118 that encircles inlet cone 38' to connect tube 114 in fluid communication with points 104.

[0035] It should be noted that arrow 52 represents rotating a centrifugal fan wheel; supply air duct 18 represents conveying discharge air 16a as supply air 16b from discharge air chamber 36 to comfort zone 14; arrows 120 represent circulating supply air 16b through comfort zone 14 to create return air 16c; the arrow of return air 16c

(immediately below fan 12) represents conveying from comfort zone 14 at least some of return air 16c to suction inlet opening 34; the arrows of suction air 16f (Fig. 3) represents conveying suction air 16f through curved inlet cone 38; pressure sensor 74 being shown connected in fluid communication with suction air 16f at points 70 and 104 represent sensing the static pressure of suction air 16f at an inner surface of a curved inlet cone; controller 80 and the expression  $CFM = (k)(SGP)^x$  represents determining a total volume flow rate of suction air flowing through curved inlet cone 38; the arrow representing signal 76, controller 80 and the arrow representing signal 84 illustrates adjusting the rotational speed of a fan based on the static pressure of suction air 16f at inner surface 40 at minor diameter 66; and VAV valves 22 represent adjustably restricting the supply air flowing to comfort zones.

**[0036]** Although the invention is described with respect to a preferred embodiment, modifications thereto will be apparent to those of ordinary skill in the art. In some embodiments, for example, the fan blades extend radially straight and/or lean back (BI) rather than leaning forward. The scope of the invention, therefore, is to be determined by reference to the following claims:

### Claims

1. A fan system for drawing suction air and discharging discharge air, the fan system comprising:

a fan housing providing a suction inlet opening for receiving the suction air and defining a discharge air chamber within the fan housing for the discharge air;

a centrifugal fan wheel disposed within the fan housing between the suction inlet opening and the discharge air chamber and being rotatable to force air from the suction inlet opening to the discharge air chamber;

a curved inlet cone encircling the suction inlet opening, the curved inlet cone includes a minor diameter and a major diameter, the minor diameter is in proximity with the centrifugal fan wheel and is downstream of the major diameter;

a static pressure receiver disposed within the discharge air chamber and being connected in fluid communication with the suction air flowing through the curved inlet cone; and

a pressure sensor connected in fluid communication with the static pressure receiver and being responsive to a static gage pressure of the suction air to provide a pressure signal indicative of the static gage pressure of the suction air at the minor diameter.

2. The fan system of claim 1, wherein the static pressure receiver comprises a conduit.

3. The fan system of claim 2, wherein the conduit is part of a manifold that places the pressure sensor in fluid communication with the suction air at a plurality of locations around the curved inlet cone.

4. The fan system of claim 1, wherein the suction air is at a minimum static gage pressure where the static pressure receiver is connected in fluid communication with the suction air flowing through the curved inlet cone.
5. The fan system of claim 1, wherein the inlet cone decreases in diameter continuously from the major diameter to the minor diameter, the inlet cone terminates at an inlet edge at the minor diameter, and the static pressure receiver is connected in fluid communication with the suction air at a location that is in proximity with the inlet edge.
6. The fan system of claim 1, wherein the centrifugal fan wheel includes a plurality of forward-curved blades that define an inner diameter and an outer diameter of the centrifugal fan wheel, each forward-curved blade of the plurality of forward-curved blades includes a leading edge upstream of a trailing edge with respect to airflow across each respective forward-curved blade, the leading edge is on the inner diameter, and the trailing edge is on the outer diameter.
7. The fan system of claim 1, further comprising:
  - a flow restriction connected in fluid communication with the discharge air chamber and being downstream thereof, the static gage pressure of the suction air flowing through the inlet cone at the static pressure receiver varying in response to variation in the flow restriction;
  - a motor driving the centrifugal fan wheel; and
  - a controller connected to receive the pressure signal indicative of the static gage pressure of the suction air, the controller being operatively connected to the motor to vary the speed thereof in response to the pressure signal.
8. The fan system of claim 7, wherein the flow restriction comprises a plurality of VAV valves that regulate the discharge air flowing therethrough.

9. A fan system for drawing suction air and discharging discharge air, the fan system comprising:

a fan housing providing a suction inlet opening for receiving the suction air and defining a discharge air chamber within the fan housing for the discharge air;

a centrifugal fan wheel disposed within the fan housing between the suction inlet opening and the discharge air chamber and being rotatable to force air from the suction inlet opening to the discharge air chamber;

a curved inlet cone encircling the suction inlet opening, the curved inlet cone includes a minor diameter and a major diameter, the minor diameter is in proximity with the centrifugal fan wheel and is downstream of the major diameter, the inlet cone decreases in diameter continuously from the major diameter to the minor diameter, the inlet cone terminates at an inlet edge at the minor diameter;

a static pressure receiver in proximity with the inlet edge and being connected in fluid communication with the suction air flowing through the curved inlet cone; and

a pressure sensor connected in fluid communication with the static pressure receiver and being responsive to a static gage pressure of the suction air to provide a pressure signal indicative of the static gage pressure of the suction air, wherein the suction air is at a minimum static gage pressure where the static pressure receiver is connected in fluid communication with the suction air flowing through the curved inlet cone.

10. The fan system of claim 9, wherein the centrifugal fan wheel includes a plurality of forward-curved blades that define an inner diameter and an outer diameter of the centrifugal fan wheel, each forward-curved blade of the plurality of forward-curved blades includes a leading edge upstream of a trailing edge with respect to airflow across each respective forward-curved blade, the leading edge is on the inner diameter, and the trailing edge is on the outer diameter.

11. The fan system of claim 9, further comprising:
  - a flow restriction connected in fluid communication with the discharge air chamber and being downstream thereof, the static gage pressure of the suction air flowing through the inlet cone at the static pressure receiver varying in response to variation in the flow restriction;
  - a motor driving the centrifugal fan wheel; and
  - a controller connected to receive the pressure signal indicative of the static gage pressure of the suction air, the controller being operatively connected to the motor to vary the speed thereof in response to the pressure signal.
  
12. The fan system of claim 11, wherein the flow restriction comprises a plurality of VAV valves that regulate the discharge air flowing therethrough.
  
13. A fan system method using a centrifugal fan wheel rotating within a fan housing for drawing suction air and discharging discharge air, the method comprising:
  - rotating a centrifugal fan wheel within a fan housing, wherein the fan housing defines a suction inlet opening for receiving suction air and defines a discharge air chamber for the discharge air;
  - conveying the discharge air as supply air from the discharge air chamber to a comfort zone;
  - circulating the supply air through the comfort zone to create return air;
  - conveying from the comfort zone at least some of the return air to the suction inlet opening of the fan housing;
  - while conveying at least some of the return air to the suction inlet opening, conveying the suction air through a curved inlet cone that leads to the suction inlet opening, wherein the suction air includes at least some of the return air, the curved inlet cone includes a minor diameter and a major diameter, the minor diameter is in proximity with the centrifugal fan wheel and is downstream of the major diameter;

sensing, at an inner surface of the curved inlet cone at the minor diameter, a static gage pressure of the suction air; and

determining a total volume flow rate of the suction air flowing through the curved inlet cone based on the static gage pressure of the suction air at the inner surface at the minor diameter.

14. The fan system method of claim 13, further comprising adjusting a rotational speed of the centrifugal fan wheel based on the static gage pressure of the suction air at the inner surface at the minor diameter.

15. The fan system method of claim 13, wherein the total volume flow rate of the suction air flowing through the curved inlet cone is determined based on a square-root of the static gage pressure multiplied by a predetermined constant.

16. The fan system method of claim 13, wherein sensing the static gage pressure of the suction air occurs at a plurality of points around the inner surface of the curved inlet cone at the minor diameter.

17. The fan system method of claim 13, wherein sensing the static gage pressure of the suction air occurs at a point on the inner surface of the curved inlet cone where the suction air is at a minimum static gage pressure.

18. The fan system method of claim 17, wherein the inlet cone decreases in diameter continuously from the major diameter to the minor diameter, the inlet cone terminates at an inlet edge at the minor diameter, and the point is in proximity with the inlet edge.

19. The fan system method of claim 13, wherein the centrifugal fan wheel includes a plurality of forward-curved blades that define an inner diameter and an outer diameter of the centrifugal fan wheel, each forward-curved blade of the plurality of forward-curved blades includes a leading edge upstream of a trailing edge with respect to airflow across each respective forward-curved blade, the leading edge is on the outer diameter, and the trailing edge is on the inner diameter.

20. The fan system method of claim 13, further comprising adjustably restricting the supply air flowing to the comfort zone by way of a VAV valve that is one of a plurality of VAV valves used in the fan system method.

FIG. 1

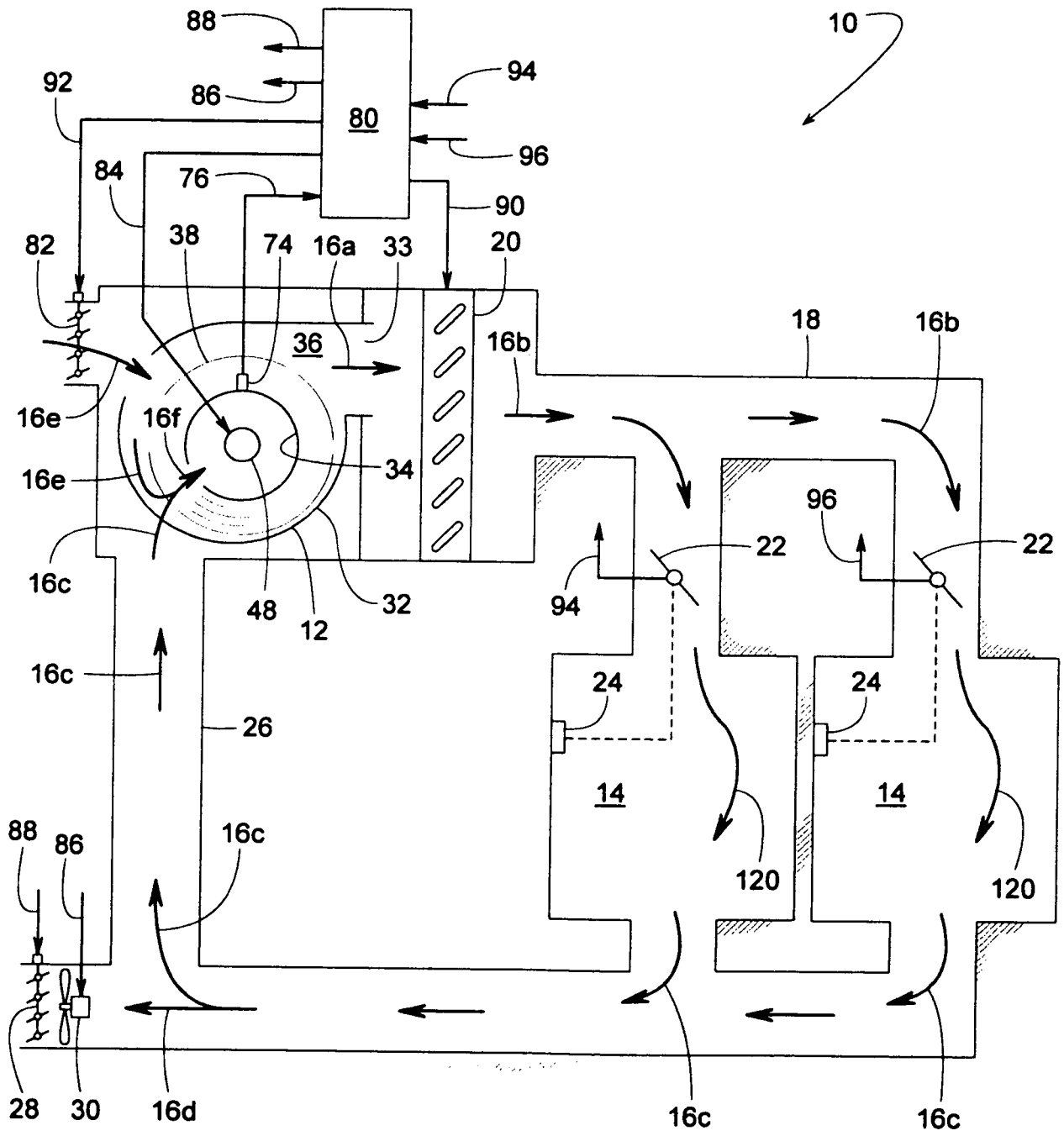

FIG. 2

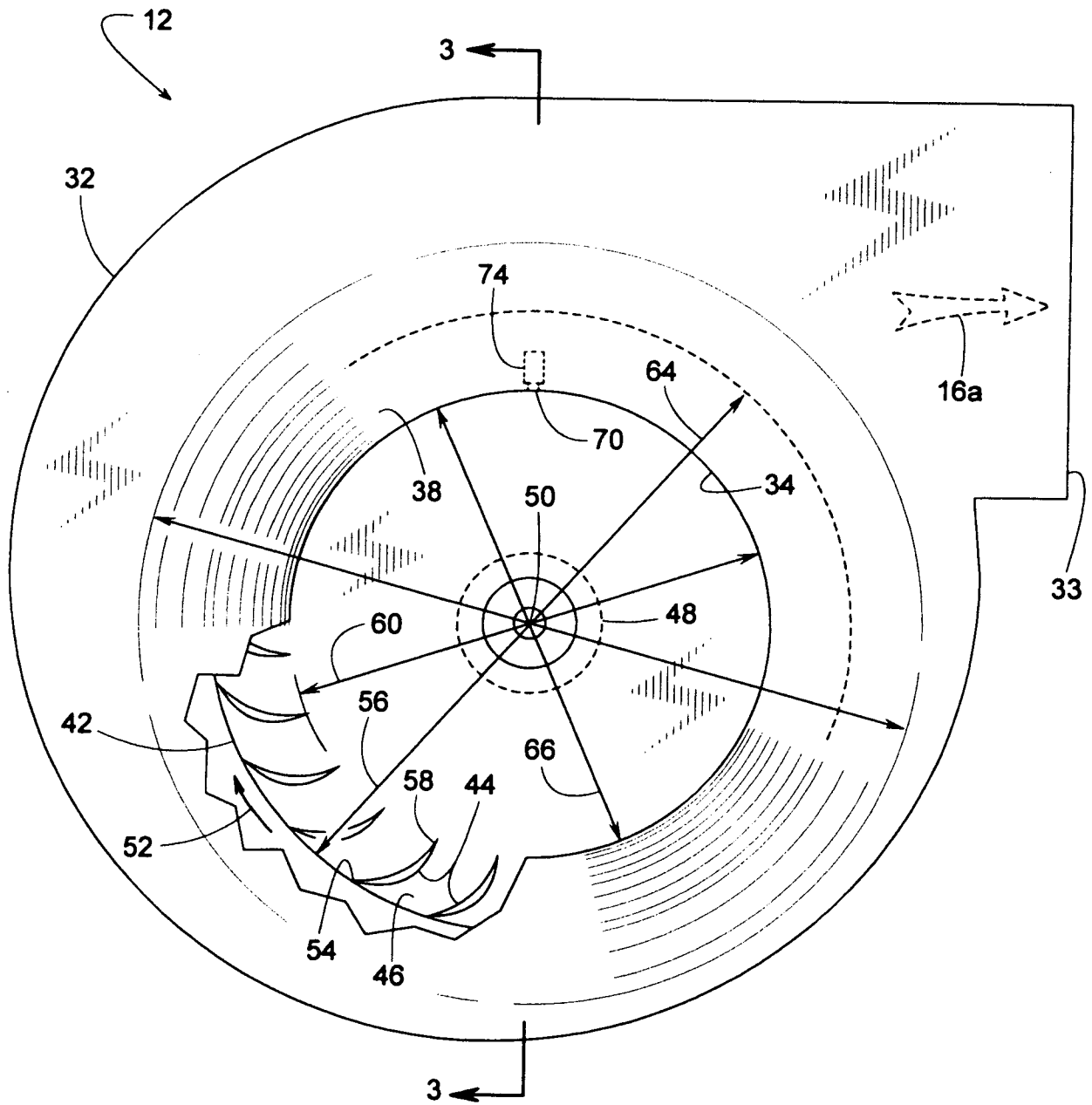

FIG. 3

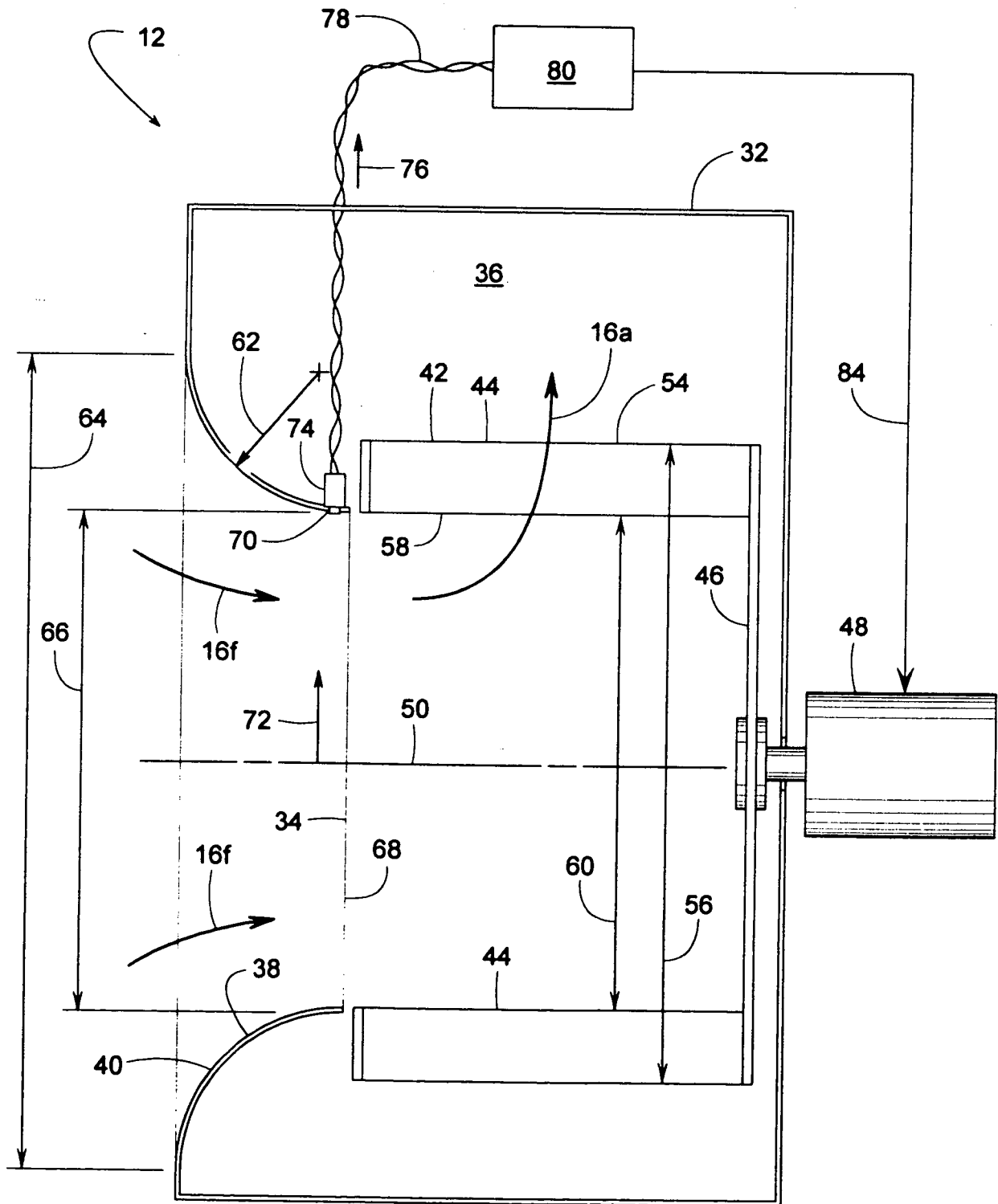

FIG. 4

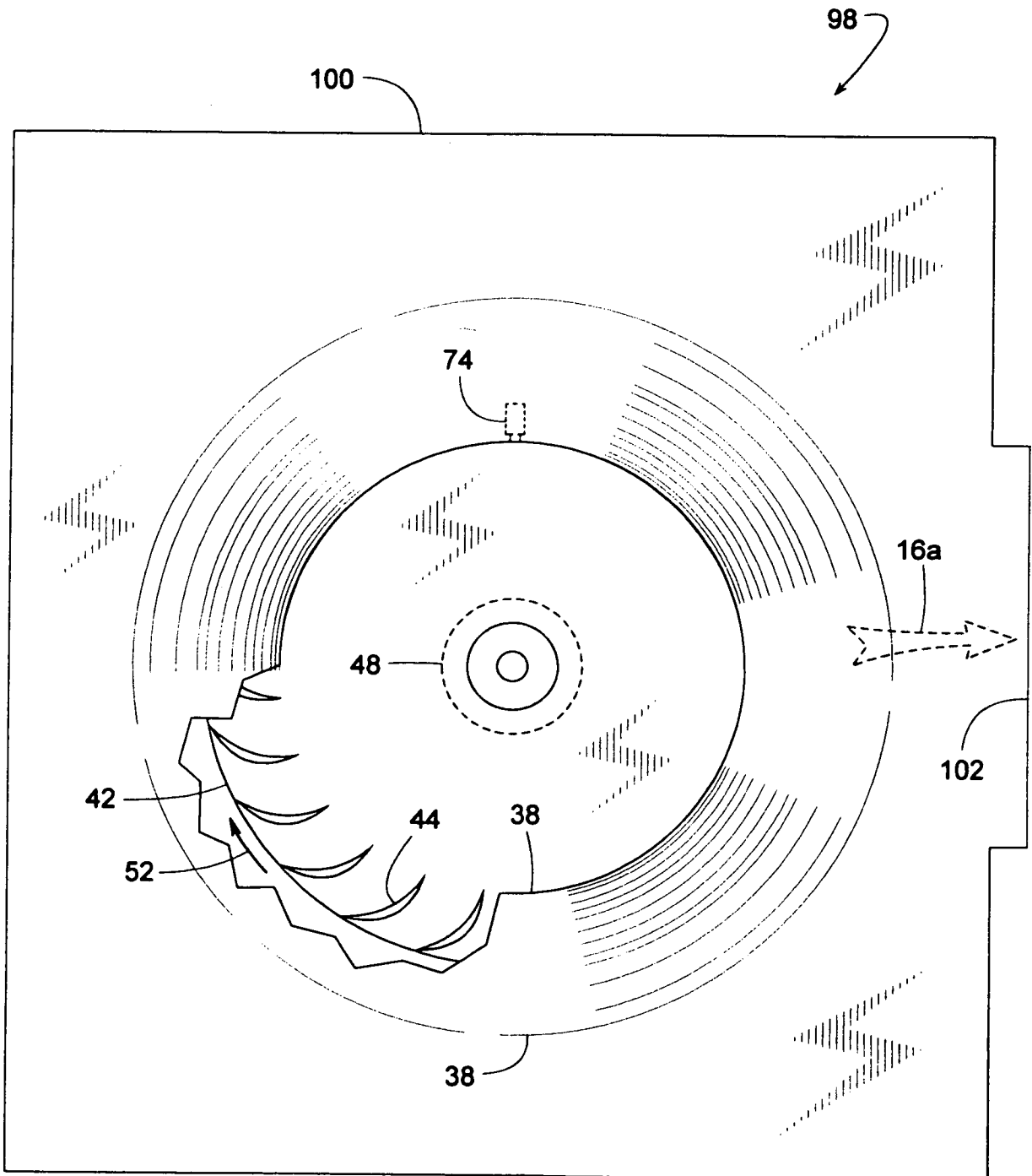

FIG. 5

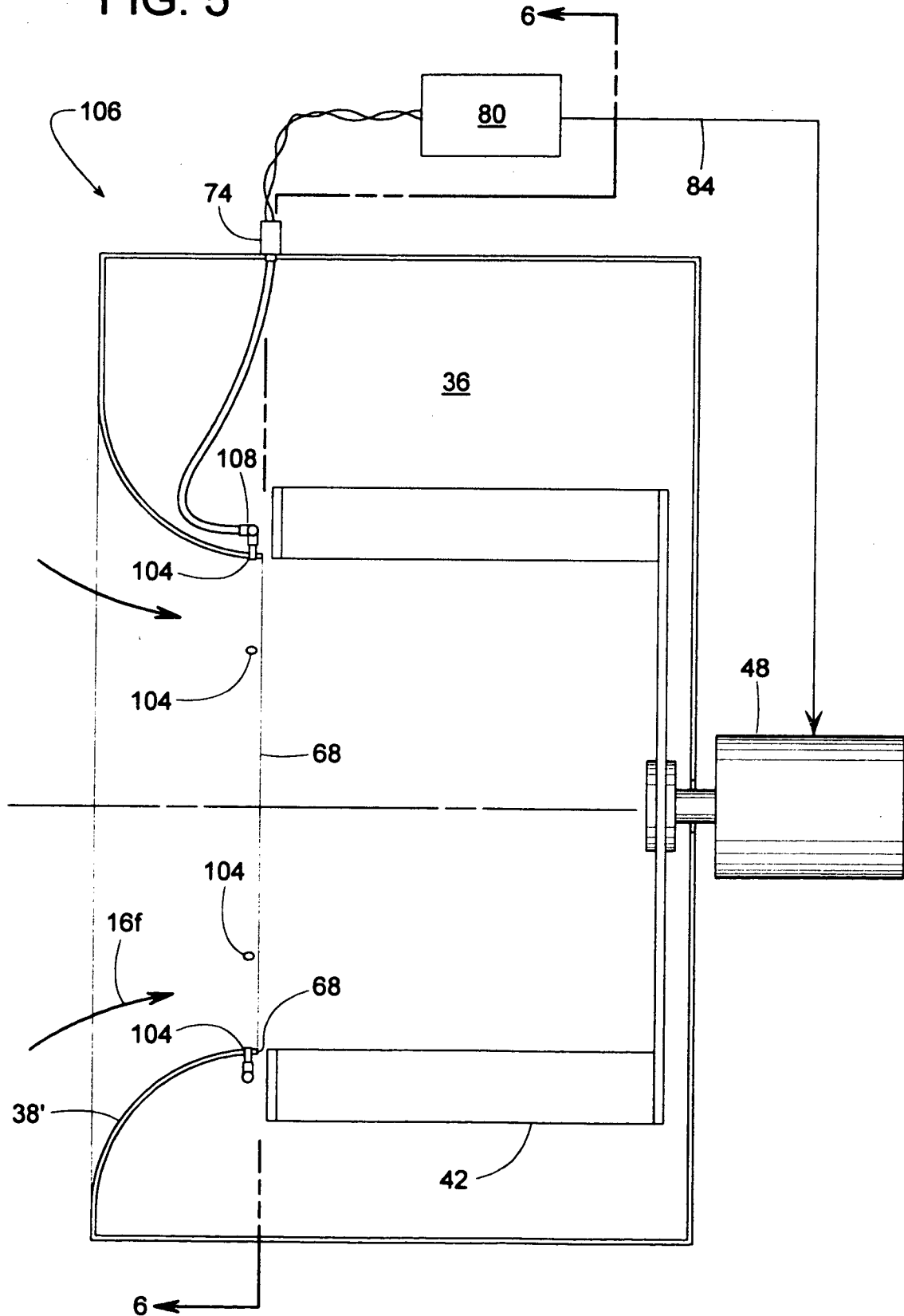

FIG. 6

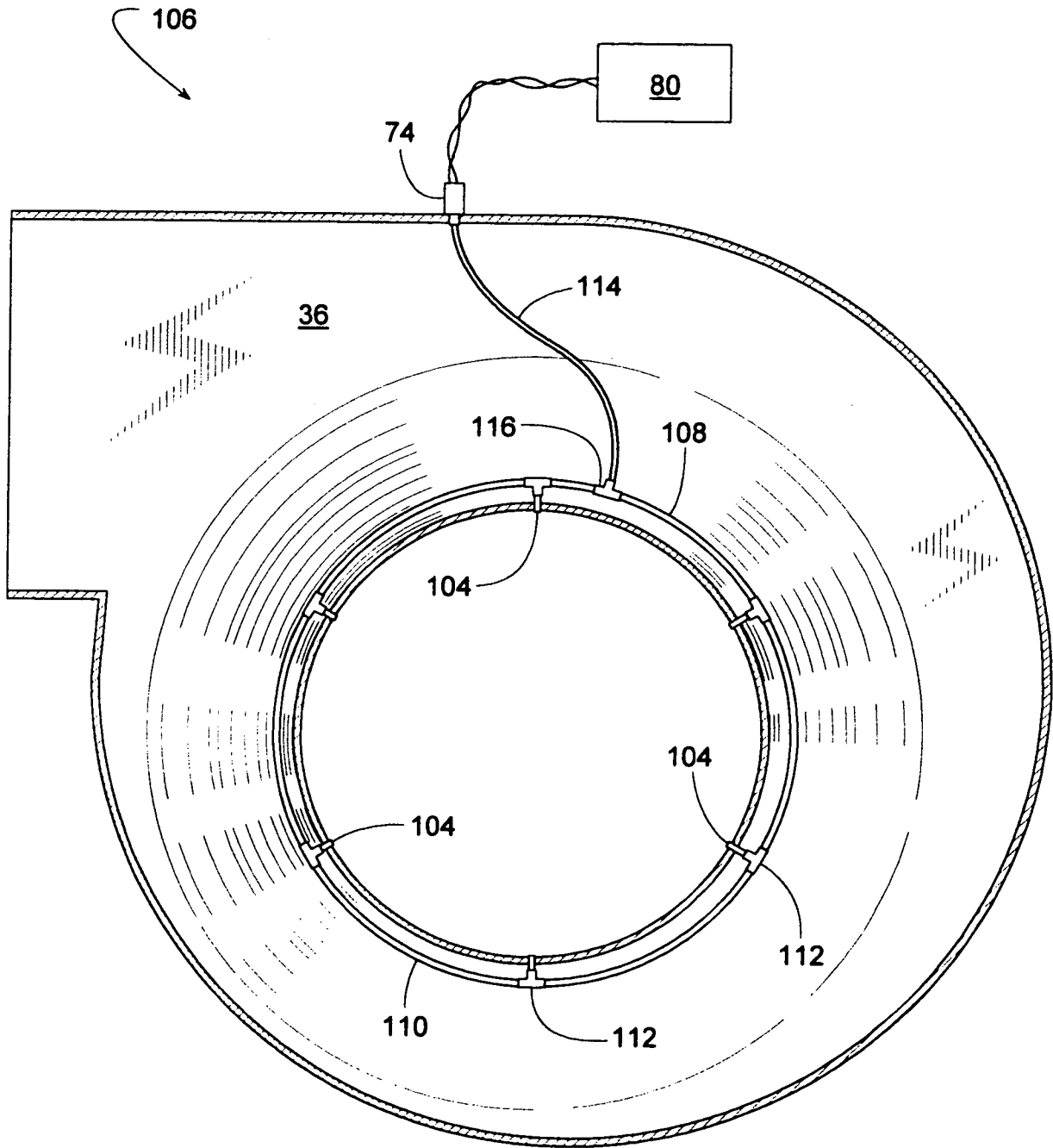
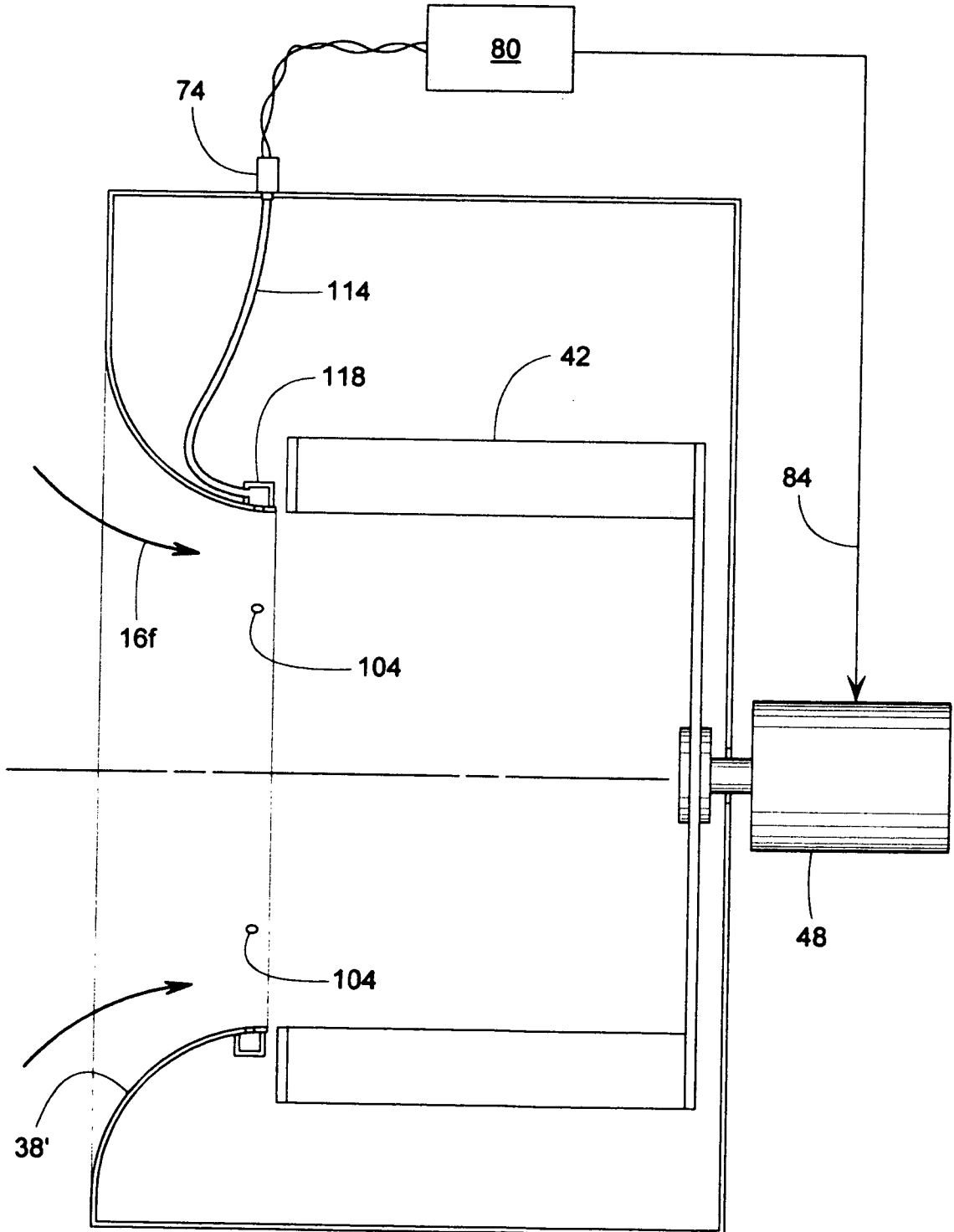

FIG. 7



# INTERNATIONAL SEARCH REPORT

International application No PCT/US2011/000498
---

**A. CLASSIFICATION OF SUBJECT MATTER**  
 INV. F04D27/00 F04D29/42 G01F1/36  
 ADD.

According to International Patent Classification (IPC) or to both national classification and IPC

**B. FIELDS SEARCHED**

Minimum documentation searched (classification system followed by classification symbols)  
 F04D G01F

Documentation searched other than minimum documentation to the extent that such documents are included in the fields searched

Electronic data base consulted during the international search (name of data base and, where practical, search terms used)

EPO-Internal, WPI Data

**C. DOCUMENTS CONSIDERED TO BE RELEVANT**

Category*	Citation of document, with indication, where appropriate, of the relevant passages	Relevant to claim No.
X	EP 0 626 519 A1 (BROD & MCCLUNG PACE CO [US]) 30 November 1994 (1994-11-30) the whole document figures 1,2 claim 1  -----	1-20
X	EP 0 419 798 A1 (GEBHARDT VENTILATOREN [DE]) 3 April 1991 (1991-04-03) the whole document figures 1,2  -----	1-20
X	US 6 186 744 B1 (WOLOCHUK MARK C [US]) 13 February 2001 (2001-02-13) the whole document figures 1,3 column 4, lines 9-28  -----	1-20
	-/--	

Further documents are listed in the continuation of Box C.

See patent family annex.

\* Special categories of cited documents :

- "A" document defining the general state of the art which is not considered to be of particular relevance
- "E" earlier document but published on or after the international filing date
- "L" document which may throw doubts on priority claim(s) or which is cited to establish the publication date of another citation or other special reason (as specified)
- "O" document referring to an oral disclosure, use, exhibition or other means
- "P" document published prior to the international filing date but later than the priority date claimed

- "T" later document published after the international filing date or priority date and not in conflict with the application but cited to understand the principle or theory underlying the invention
- "X" document of particular relevance; the claimed invention cannot be considered novel or cannot be considered to involve an inventive step when the document is taken alone
- "Y" document of particular relevance; the claimed invention cannot be considered to involve an inventive step when the document is combined with one or more other such documents, such combination being obvious to a person skilled in the art.
- "&" document member of the same patent family

Date of the actual completion of the international search  <p style="text-align: center; font-size: 1.2em;">27 June 2011</p>	Date of mailing of the international search report  <p style="text-align: center; font-size: 1.2em;">04/07/2011</p>
--	---

Name and mailing address of the ISA/ European Patent Office, P.B. 5818 Patentlaan 2 NL - 2280 HV Rijswijk Tel. (+31-70) 340-2040, Fax: (+31-70) 340-3016	Authorized officer  <p style="text-align: center; font-size: 1.2em;">Ingelbrecht, Peter</p>
--	---

**INTERNATIONAL SEARCH REPORT**

International application No PCT/US2011/000498
---

C(Continuation). DOCUMENTS CONSIDERED TO BE RELEVANT

Category*	Citation of document, with indication, where appropriate, of the relevant passages	Relevant to claim No.
A	EP 2 093 428 A1 (VENT AXIA GROUP LTD [GB]) 26 August 2009 (2009-08-26) the whole document -----	1-20
A	DE 10 2004 038523 A1 (AUDI NSU AUTO UNION AG [DE]) 16 March 2006 (2006-03-16) the whole document -----	1-20

**INTERNATIONAL SEARCH REPORT**

Information on patent family members

International application No

PCT/US2011/000498

Patent document cited in search report	Publication date	Patent family member(s)	Publication date
EP 0626519	A1	30-11-1994	CA 2123640 A1 18-11-1994
			JP 7151093 A 13-06-1995
			US 5586861 A 24-12-1996
-----			
EP 0419798	A1	03-04-1991	DD 297705 A5 16-01-1992
			DE 8911433 U1 23-11-1989
			ES 2047217 T3 16-02-1994
-----			
US 6186744	B1	13-02-2001	NONE
-----			
EP 2093428	A1	26-08-2009	GB 2457731 A 26-08-2009
-----			
DE 102004038523	A1	16-03-2006	NONE
-----			