



(22) Date de dépôt/Filing Date: 1991/09/10
 (41) Mise à la disp. pub./Open to Public Insp.: 1992/03/13
 (45) Date de délivrance/Issue Date: 2002/07/23
 (30) Priorités/Priorities: 1990/09/12 (581,584) US;
 1991/06/03 (709,504) US

(51) Cl.Int.⁵/Int.Cl.⁵ C12N 1/04, A01N 1/00, C12N 5/02,
 F25D 31/00

(72) Inventeurs/Inventors:
 Livesey, Stephen A., AU;
 Del Campo, Anthony A., US;
 Nag, Abhijit, US;
 Nichols, Ken B., US;
 Piunno, Carmen, US;
 Ross, David P., US

(73) Propriétaire/Owner:
 LIFECELL CORPORATION, US

(74) Agent: FINLAYSON & SINGLEHURST

(54) Titre : METHODE ET APPAREILLAGE POUR LA CRYOPRESERVATION, LA STABILISATION A SEC ET LA REHYDRATATION DE SUSPENSIONS BIOLOGIQUES

(54) Title: METHOD AND APPARATUS FOR CRYOPREPARATION, DRY STABILIZATION AND REHYDRATION OF BIOLOGICAL SUSPENSIONS

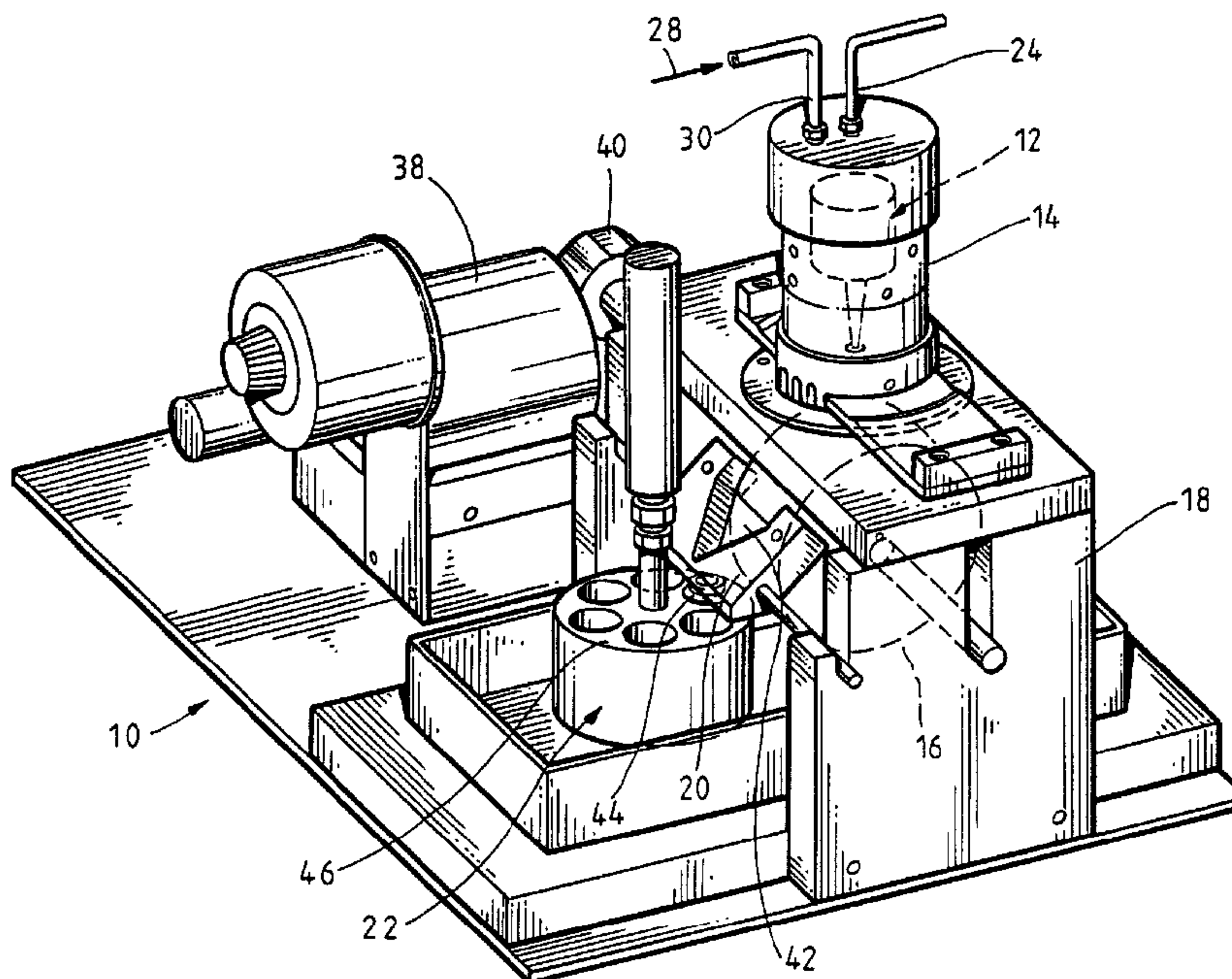

(57) Abrégé/Abstract:

This invention relates to methods, apparatus and solutions for cryopreserving microscopic biological materials for biologically extended periods of time. The method comprises treating a suspension of biological material, in an appropriate buffer, with a cryoprotectant or combination of cryoprotectants which raises the glass transition temperature range of the sample. One or more dry protectants may be added to the cryosolution. The cryosolution is then nebulized and rapidly cooled with novel apparatus, dried by molecular distillation, stored and then rehydrated in a buffer prior to its use. The solutions comprise novel mixtures of cryoprotectants.

METHOD AND APPARATUS FOR
CRYOPREPARATION, DRY STABILIZATION
AND REHYDRATION OF BIOLOGICAL SUSPENSIONS

5

ABSTRACT

This invention relates to methods, apparatus and solutions for cryopreserving microscopic biological materials for biologically extended periods of time. The method comprises treating a suspension of biological material, in an appropriate buffer, with a cryoprotectant or combination of cryoprotectants which raises the glass transition temperature range of the sample. One or more dry protectants may be added to the cryosolution. The cryosolution is then nebulized and rapidly cooled with novel apparatus, dried by molecular distillation, stored and then rehydrated in a buffer prior to its use. The solutions comprise novel mixtures of cryoprotectants.

10

15

20

25

30

5

10

METHOD AND APPARATUS FOR
CRYOPREPARATION, DRY STABILIZATION
AND REHYDRATION OF BIOLOGICAL SUSPENSIONS

15

This invention relates to methods and apparatus for preparing biological suspensions for long term preservation in the dry state for later use. These methods avoid deleterious modifications of the biological ultrastructure during the preservation process. More particularly, the present invention relates to the preservation of microscopic biological materials which are found or placed in a suspension prior to treatment.

20

In its preferred form, the method of this invention includes the steps of preparing a cryosolution by treating a biological material with a protectant or combination of protectants, cooling, storing under temperature conditions which preclude devitrification or recrystallization, and drying under controlled temperature, vacuum and condenser conditions. The biological material can be rehydrated prior to use if desired.

25

30

The desire to preserve biological materials at ambient conditions for future use has existed for a long time in the scientific community. For example, the dry preservation of erythrocytes has been attempted by several groups over the last 30 to 40 years. The ability to dry the erythrocytes and reconstitute them at a later date at ambient conditions would have far reaching benefits during times of

2051092

disaster, wars, and in remote locations. It would be a significant advancement in the art to be able to store dried, powdered erythrocytes in a sterile container such that they could be reconstituted by simply adding an appropriate buffered solution prior to use.

5

Similarly, freeze drying of cultured mammalian cells has been attempted without success. With the advent of biotechnology and the identification of functionally important cells, e.g., hepatocytes and pancreatic islets, a method of prolonged storage under ambient conditions would be invaluable.

10

Many complex macromolecules, either antibodies or recombinant proteins which are to be used therapeutically, show reduced activity following freezing or freeze drying. The development of methods to enable prolonged ambient storage without significant loss of activity is an important component in their ultimate therapeutic effectiveness.

15

Further, the necessity to control or abate viral infections has been a major medical concern for decades. Basically, the eradication and/or control of viral infections involves the production of a variety of different and highly potent vaccines.

20

Quantitative and qualitative production of pure and potent viral antigens or immunogens is difficult as well as expensive. This is usually due to the fact that many viruses replicate very slowly, if at all, in controlled cell culture environments. If the virus of choice seldom replicates in the test tube, then the production of the specific viral particle becomes less favorable and effective, as well as more expensive. Therefore, it is essential that, once vaccine material is produced, its biological activity be preserved for an extended period of time.

25

One feature common to all these examples is that the initial configuration of the sample is a microscopic biological material in the form of a suspension or

30

emulsion. Once an effective suspension has been produced, preserving and storing this material is of utmost importance.

The field of cryopreservation and dry stabilization is rapidly developing and advancing. United States Patent 4,865,871, issued September 12, 1989 describes an apparatus and method for the cryopreservation of a biological tissue sample and may be referred to for further details. The method comprises treating a biological tissue sample with a cryoprotectant which raises the glass transition temperature range of the sample, vitrifying the tissue sample under cryogenic temperature conditions at a specific rate to preclude the formation of significant resolvable ice crystals, equilibrating the depressurized, vitrified tissue in a sample holder and then dehydrating the tissue sample by molecular distillation by the addition of energy until substantially no vaporized water can be detected in the atmosphere surrounding the tissue sample.

The first critical processing step in cryopreservation must be performed in such a way as to satisfy two essential criteria. First, the biological material must not undergo irreversible damage due to the multiplicity of changes which occur within a sample during cooling. These changes include mechanical damage due to ice formation, cell-to-cell fusion due to the decrease in the solute volume available, and changes in acidity (pH) and salt or solute concentrations due to the segregation of solute and water. Second, the condition of the sample following cooling must be compatible with subsequent drying and reconstitution. This includes such parameters as sample size, ice forms created, and the nature and final concentration of additives or excipients.

In satisfying these two criteria, the cryopreservation process represents a balance between the use of cryoprotective agents (CPA's) to minimize changes during freezing by chemically increasing the volume of the ice free zone for a given cooling rate, and the cooling rate itself. Several potential combinations are possible, some of which are summarized in the following table:

<u>Cooling Mode</u>	<u>Approximate Cooling Rate</u>	<u>Final CPA Concentration</u>
5 Ultra Rapid	300,000°C/sec.	Zero
Rapid	50,000-100,000°C/sec.	Low
Intermediate	500-2,500°C/sec.	Intermediate
Slow	1-20°C/min.	High

10 Inherent in most processes for cryopreparation and freezing of biological materials is the concomitant artifact creation, sample shrinkage and resultant damage to and modification of sample characteristics. These sample characteristic modifications, whether in the form of artifacts or the like, must be controlled and minimized. The acceptable limits for sample modification are defined by the anticipated end use of the cryoprepared material. For example, slow rate cooling
15 results in extremely high final concentrations of CPA to which the sample is exposed. This results in potential deleterious effects at each step of the process. These include toxicity during cooling, incompatibility during drying and severe osmotic stresses during rehydration.

20 One of the problems which has been encountered in cryopreservation has been the lack of an effective and efficient apparatus and method for rapidly cooling suspensions of biological materials. Some prior art processes have utilized air guns or air brushes to generate microdroplets which are then cooled. However, these devices cause shear stresses which damage the cellular material. Additionally, in
25 the prior art processes, the microdroplets were sprayed directly into a liquid cryogen. This posed problems in collection of the frozen microdroplets and also had the potential for contaminating the sample. Accordingly, there has existed in the art a need for a method and apparatus for the cryopreparation of a suspension of biological materials which was practical, cost effective and sterile.

30

Various processes have been utilized in the past for drying frozen biological samples. These include freeze drying and molecular distillation drying. Examples of apparatus and methods used in molecular distillation drying are disclosed in U.S.

Patent Nos. 4,510,169, 4,567,847, 4,676,070, 4,799,361, 4,865,871 and 4,964,280.

Thus, it would be an important advancement in the art to provide methods and apparatus of cryopreparing and dry stabilizing biological samples without overt disruption or destruction of the morphological characteristics of the ultrastructure of the sample. Such methods and apparatus should provide for the cryostabilization of microscopic, biological samples by dehydrating the samples, in which the water molecules are maintained in a predetermined optimal ice phase, without creating unnecessary artifacts and resultant undesired ultrastructural and morphological damage while the water is being removed.

The invention in one broad aspect pertains to a method for preserving a suspension of biological material comprising:

(a) preparing a cryosolution of a suspension of biological material, the cryosolution comprising a buffer, a cryoprotectant and a biological material;

(b) nebulizing the cryosolution with a low frequency, ultrasonic nebulizer to form microdroplets;

(c) cooling the microdroplets at a rate which results in the formation of amorphous phase ice and/or cubic phase ice with or without hexagonal phase ice in the cryosolution by spraying the microdroplets on a solid cryogenic surface;

(d) continuously removing the cryosolution from the solid cryogenic surface after cooling to replenish the surface for further cooling of additional microdroplets; and

(e) drying the cooled cryosolution to form a dried cryosolution.

Another aspect of the invention provides an apparatus for rapid cryofixation of suspensions of microscopic biological materials comprising a nebulizer for creating microdroplets of a suspension of a microscopic biological material in a laminar flow of gas, the gas propelling the microdroplets away from the nebulizer, preferably the microdroplets having diameters of about 25 μm to about 250 μm . An internally cooled cryogenic surface is provided for rapidly cooling the microdroplets preferably at an approximate cooling rate of 50,000° to 100,000° C./sec. the internally cooled cryogenic surface being functionally located in the

- 5a -

laminar flow of gas so that the microdroplets contact and are cooled by the internally cooled cryogenic surface. An internally cooled collector removes the cooled microdroplets from the cryogenic surface and a removable sample holder is provided for receiving the cooled microdroplets.

Still further the invention comprehends a cryoprotective solution selected from the group consisting of a mixture of 0.5 molar dimethyl sulfoxide, 0.5 molar propylene glycol, 0.25 molar 2,3 butanediol, 1.0 molar proline, 2.5% raffinose and 15% polyvinylpyrrolidone; a mixture of 0.5 molar dimethyl sulfoxide, 0.5 molar propylene glycol, 0.25 molar 2,3 butanediol, 10% raffinose, 6% trehalose, 6% sucrose, 12% polyvinylpyrrolidone and 12% dextran; and a mixture of 0.5 molar dimethyl sulfoxide, 0.5 molar propylene glycol, 0.25 molar 2,3 butanediol, 2.5% raffinose, 12% sucrose, 15% polyvinylpyrrolidone and 12% dextran.

FIG. 1 is a schematic flow diagram of the method of this invention.

FIG. 2 is a perspective view of a rapid cryofixation device forming a part of this invention.

FIG. 3 is a cross-sectional view of a portion of the apparatus illustrated in FIG. 2 generally taken along lines 3-3.

The present invention relates to a method and apparatus for cryopreserving and drying microscopic biological materials which are generally prepared in a suspension. As used in this application, suspensions also include emulsions. The method of this invention includes the cryopreparation and dry stabilization of the biological materials.

In the preferred embodiment, the cryopreparation is achieved by first preparing a cryosolution of the biological material which includes an appropriate buffer, one or more cryoprotectants and/or dry protectants, and a suspension of the biological material. The cryosolution is then cooled in such a manner to functionally result in the formation of amorphous phase ice, cubic phase ice and

hexagonal phase ice in the cryosolution without damaging the structure or morphology of the biological material. The cryosolution is then dried to remove the various ice phases to a final product with residual water content less than about 5%, preferably less than about 3%.

5

The sample is pretreated with protective agents, i.e. cryoprotectants and dry stabilizers, and subjected to cooling rates and final temperatures that minimize ice crystal formation. It should be understood that the process of this invention is adaptable to whatever specific end use is contemplated. For example, in certain situations an absolute minimum amount of ultrastructural damage may be tolerated while in other applications the end use may not be as sensitive to cell morphology. By the proper selection of cryoprotective agents and the use of preselected drying parameters, almost any biological sample in suspension can be cryoprepared for a suitable desired end use.

15

After functionally effective amounts of cryoprotectants and/or dry stabilizers have been added to the sample, the sample is cooled to a temperature at which chemical activity is essentially arrested. The cooling is completed in a fashion such that the crystalline structure of the liquid molecules within the biological material cause minimal levels of damage.

20

Cooling of the solution is achieved by nebulizing the solution to form discrete droplets, said droplets being less than about 200 μ m in diameter. The microdroplets are then sprayed onto a rotating cryogenic surface which is internally cooled by a cryogenic fluid to a temperature of less than about -160°C. The frozen microdroplets are mechanically removed from the rotating cylinder by a collector, also cooled by internal cryogen, and are placed in a sample collection device for subsequent drying.

25

Drying of the frozen microdroplets is accomplished by use of a conventional freeze dryer or a molecular distillation dryer which is known in the art and is

30

discussed further below. Where conventional freeze drying is used, the unique aspect of the method relates to the microdroplet configuration and the lack of damage during microdroplet formation using low frequency ultrasound. As freeze drying is currently performed at temperatures above -70°C , water within the sample will exist either as hexagonal ice or in combination with the cryoprotectant in the ice free zone of the sample. The efficiency of drying will be greatly augmented by the microdroplet configuration of the sample. Molecular distillation drying is performed under conditions of temperature and pressure that result in the removal of crystalline fluids without substantial ultrastructural damage.

5
10

In the context of molecular distillation drying, the drying process associated with the process of this invention is referred to as transitional, phasic drying. This means that water, in the form of ice crystals, is removed from the cooled samples during the transition temperature from one ice phase to another, e.g., from cubic to hexagonal.

15

Also, in the preferred method of this invention, the dried biological solution is placed in a biologically inert container in a dry inert gas atmosphere or at low pressure. In this fashion, the biological materials can be cryoprepared, dry stabilized and preserved for biologically extended periods of time.

20

The present invention can be used to preserve many different types of biological materials. It is anticipated that the method can be used to preserve materials such as red blood cells, mammalian cultured cells, platelets, leukocytes, Factor VIII, sperm, pancreatic islets, marrow cells, viruses and vaccines. Suitable materials can be either molecular, viral, bacterial, cellular, or subcellular.

25

Thus, it is an objective of this invention to control and minimize undesirable artifact formations while preserving and storing biological samples. It is essential to emphasize that throughout preservation and storage of the samples, the activity and integrity of the samples should be maintained.

30

The method of this invention represents a cryostabilization breakthrough that permits preserving and storing dried, microscopic biological materials prepared as a suspension. This invention is cost effective, safe and the samples that are stored maintain their biological activity even after extended periods of storage. The
5 specific desired extended time period will depend on the biologic material being preserved and the intended end use. Inexpensive and effective preservation and storage of potent biological materials is a necessity for the field of biotechnology to advance.

10 It has recently been postulated and confirmed that there is a direct correlation between the temperature of a biological material sample and the crystalline configuration of the fluid molecules in the sample. The understanding of this interrelationship has facilitated the development of the process of this
15 invention in which the control of the sample temperature results in the control of crystalline structure and thus the control of ultrastructural damage. Importantly, the crystalline configuration of the fluid molecules has a direct bearing on the damage done to sample morphology and function.

20 The present invention provides a method and apparatus for preserving microscopic biological materials through the steps of cryopreparation and dry stabilization.

25 The method of the present invention can best be understood by reference to Figure 1 which schematically illustrates the steps involved in the method of the present invention.

30 In the preferred embodiment, the microscopic biological material to be preserved is first formulated into a cryosolution. The cryosolution generally contains a suspension of the biological material, an appropriate buffer and one or more cryoprotectants and/or dry stabilizers. The type and amount of buffer and protectant can be varied and is determined by the particular material being

preserved and its intended end use. Under certain applications, no protectant need be used. Under other applications, various concentrations and combinations of protectants and dry stabilizers can be used as discussed further below.

After the cryosolution has been prepared, it must be nebulized before it can be cooled. In the preferred embodiment, a low wattage, low frequency, ultrasonic nebulizer is used to create the microdroplets.

In the preferred embodiment, the nebulized cryosolution is directed to a cryogenic surface for rapid cooling. The nebulized cryosolution should be directed to the surface under conditions such that it does not undergo any substantial, slow precooling prior to the rapid cooling event.

In the preferred embodiment, a continuously replenished cryogenic surface is utilized to rapidly cool the nebulized cryosolution. It comprises a rotating metal cylinder which is internally cooled with a liquid cryogen.

The frozen cryosolution is removed from the cryogenic surface and placed in a suitable collection device such that it can be transferred to a suitable drying apparatus. It is important that the frozen cryosolution remain at cryogenic temperatures during all steps including transportation from the freezing device to the dryer. In addition, it is important that the cryosolution at no time comes into contact with liquid cryogen which has been introduced into the device to provide cooling. The frozen cryosolution in the collection device can either be taken directly to a dryer or stored at cryogenic temperatures.

In the preferred embodiment, drying is achieved either by conventional freeze drying or by using a molecular distillation dryer. Suitable molecular distillation dryers can be obtained from LifeCell Corporation in The Woodlands, Texas and are disclosed in U.S. Patent Nos. 4,567,847 and 4,799,361 which may be referred to for further details.

The preferred cooling apparatus to be utilized in the practice of the present invention is a novel cryofixation device illustrated in Figures 2 and 3.

5 Referring now to Figures 2 and 3, the rapid cryofixation device is generally referred to at 10. It comprises a nebulizer 12 positioned within a nebulizer column 14. A cryogenic surface 16 is positioned at the outlet of nebulizer column 14 and is contained within a housing 18. A collector 20 is positioned adjacent cryogenic surface 16 to remove the frozen cryosolution and position it within a sample holder 22. Sample holder 22 can be used to transport the frozen cryosolution to a
10 molecular distillation dryer where it is further processed or to a storage area.

Nebulizer 12 is a low wattage, low frequency, ultrasonic nebulization device such as an ultrasonic atomizing nozzle available from Sonotek. The nebulizer was modified with respect to cryosolution delivery to minimize contact of the
15 cryosolution with the nebulizer components. This was achieved by bypassing the normal fluid conduit and delivering the cryosolution only to the tip of the nebulizer via a sterilized, disposable conduit 24. In this way, exposure of the cryosolution to heating and ultrasonics was minimized. This configuration is also important to maintaining sterility of the cryosolution during processing. Sterility was one of the
20 problems encountered in prior art processes which used air guns or sprays. Conduit 24 is connected to a suitable container (not shown) which holds the cryosolution.

This particular nebulizer can form microdroplets with diameters on the
25 order of about 25 μm to about 250 μm . Diameters on the order of 25 to 200 μm are appropriate for rapid cooling. Microdroplet diameters on the order of 25 to 100 μm are preferred in order to achieve maximum cooling rates and short drying times. The nebulizer can be adjusted to achieve cryosolution flow rates of 5-10 ml. per minute without significant damage to the biological material.

30

Nebulizer 12 is mounted within nebulizer column 14 by suitable brackets 26. A dry gas 28 at room temperature is introduced into the top of column 14 through tubing 30. Nebulizer 12 is mounted in such a manner that gas 28 can flow past nebulizer 12 with laminar flow as indicated by arrows 32. The flow of inert gas 28 ensures that the nebulized sample does not undergo a slow precooling process prior to rapid cooling on cryogenic surface 16. Many different types of gases may be utilized such as nitrogen, helium, oxygen and argon. The flow rate of the gas should be adjusted so as to prevent slow precooling but should not be so high as to cause turbulent flow or significant warming of the cryogenic surface.

5

10

The cryosolution containing the microscopic biological sample is discharged from nozzle 34 of nebulizer 12 as microdroplets 36 which quickly encounter cryogenic surface 16.

15

In the preferred embodiment, cryogenic surface 16 comprises a hollow cylinder with high thermal conductivity presenting a rotating mirror finished metal surface. The thermal capacity of this surface together with internal cryogen is such that the nebulized sample can be rapidly cooled without contacting the liquid cryogen. A suitable drive motor 38 and gear mechanism 40 are used to rotate cryogenic surface 16.

20

The rate of rotation is dependent upon the size of the cryogenic surface and the flow rate of the cryosolution. In the preferred embodiment, the cryogenic surface has a diameter of about 4 inches, a width of about 2 inches and a length of about 12 inches.

25

The cylinder of cryogenic surface 16 is internally cooled with a liquid cryogen which is introduced into the cylinder through suitable connections. This allows the cryosolution to be cooled without contact with the cryogen which could cause problems with sterility. Additionally, by using a high thermally conductive metal as the conduit for heat flow between the sample and the liquid cryogen,

30

vapor formation due to heating of the liquid cryogen which usually surrounds and insulates the sample from the thermal sink is avoided. This allows the achievement of much higher cooling rates.

5 The cylinder of cryogenic surface 16 can be formed of materials such that it is a permanent portion of the cryofixation device or can be designed with a disposable configuration. Suitable materials include copper, aluminum and chromium or diamond coated aluminum.

10 Microdroplets 36 which are frozen on cryogenic surface 16 are removed by collector 20 which is formed from an autoclavable material such as polyethylene terephthalate. Collector 20 includes a blade 42 for removing the frozen
15 microdroplets from the cryogenic surface 16. They are then directed into a suitable sample holder 22. In one preferred embodiment, sample holder 22 comprises a sample vial 44 and a vial holder 46. In the illustrated embodiment, vial holder 46
is designed to hold six sample vials. The sample holder is designed such that it can be removed from cryofixation device 10 and placed within a molecular distillation dryer for drying of the cryosolution.

20 In another preferred embodiment, sample holder 22 comprises a collection bag held in a precooled transfer carrier similar to vial holder 46. The bag is fabricated from a suitable material such as polytetrafluoroethylene (PTFE) having a
15 micron pore size. This allows the sample to be contained within the bag while allowing water vapor to escape during drying. Following collection, the bag is
25 sealed to contain the sample through subsequent processing steps.

 In the practice of this invention, it is a fundamental prerequisite that suitable desired biological samples be obtained. Virus or vaccine samples, antibodies and recombinant proteins are commercially available from a variety of sources. The
30 particular type of virus or vaccine sample, antibody or recombinant protein is not

limiting on the method of this invention. However, the cryopreservation of the biological sample is enhanced if the sample to be processed is fresh.

5 Human erythrocytes can be obtained fresh from donors and collected in appropriate anticoagulant containers and subjected to separation and washing procedures. Alternatively, erythrocytes can be processed from standard blood bank supplies if they are used within six days of collection.

10 The cryopreparation of the biological sample takes place preferably immediately after it is received. Biological materials generally undergo significant deterioration during freezing and thawing or following freeze drying by conventional means. Accordingly, these steps should be avoided prior to processing by the method described in this application.

15 The initial steps of cryopreserving the biological samples includes preparing a cryosolution prior to the cooling step. The cryosolution comprises a biological suspension, an appropriate buffer and one or more cryoprotectants and/or dry protectants.

20 Microscopic biological samples are most often obtained as a suspension. The exact ingredients of each available suspension is not considered to be a component of this invention. The detailed composition of each suspension will vary from source to source and the specific ingredients may often involve proprietary information. However, in general, microscopic biological suspensions include a mixture of a percentage of biological material in water, phosphate
25 buffered saline or another compatible solution. If the solution composition is not compatible with the cryopreservation process, the undesired components may be eliminated by concentrating the biological suspension. The biological sample may then be resuspended in a compatible solution.

30

In addition to the biological suspension, the cryosolution generally contains an appropriate buffer. This may involve one of many different organic buffers which are known to those skilled in this art. The inventors prefer to use an organic buffer selected from the group consisting of: Tris (2-Amino-2-
5 (hydroxymethyl)-1,3-propanediol); MES (2- [N-Morpholino] ethanesulfonic acid); Ammediol (2-amino-2 methyl-1,3-propanediol); MOPS (3-[N-Morpholino] propanesulfonic acid); and PIPES (Piperazine-N-N'-bis [2-ethanesulfonic acid] and 1,4- Piperazine-diethanesulfonic acid).

10 Alternatively, a low salt or physiological buffer may be more appropriate in certain applications. Low salt buffers include mixtures currently used in blood storage such as (1) LISS - 8 gms glycine, 20 mls of 0.15M phosphate buffer pH 6.7 - 8.4 and 1.8 gm sodium chloride made up to 1000 mls pH 6.7; (2) LISP - 16
15 gms glycine, 20 mls of 0.15M phosphate buffer pH 6.7 - 8.4, 1.8 gm sodium chloride, 5.0 gms glucose, 0.06 gm calcium chloride and 0.1 gms adenine made up to 1000 ml pH 6.7; (3) Adsol - 0.9% NaCl, 0.75% mannitol, 2.2% dextrose, and 0.027% adenine; (4) RBC Buffer - 0.875% dextrose 0.9% NaCl, 0.214% mannitol, 0.008% adenine, 0.255% sodium citrate, 0.029% citric acid, and 0.022% monobasic sodium phosphate; or modifications thereof such as (5)
20 Buffer A - 16 mM phosphate buffer, pH 7.4, 5 mM KCl, 4 g/dl BSA and lactose 6.9 g/lit, and (6) Buffer B - 16 mM phosphate buffer, pH 7.4, 5 mM KCl and lactose 15 g/lit. Physiological buffers include various phosphate buffered saline solutions. Additional buffers of importance are those containing magnesium as a component.

25

The cryosolution also generally contains a cryoprotectant. Cryoprotectants raise the glass transition temperature range of the sample thereby stabilizing the sample in the frozen state. By raising this range, the sample can be dried at a faster rate. The cryoprotectant also permits decreased ice formation for a given
30 cooling rate allowing vitrification of larger samples. With current methods of ultrarapid cooling in the absence of cryoprotectants, vitrification of the sample is

only achieved to a depth of a few microns. Cubic and hexagonal ice are then encountered. By appropriately selecting the cryoprotectant and the cooling method, apparent vitrification to a depth of several millimeters can be achieved.

5 Various cryoprotectants can be used in the present invention. These include: dimethyl sulfoxide (DMSO), dextran, sucrose, 1,2 propanediol, glycerol, sorbitol, fructose, trehalose, raffinose, hydroxyethyl starch, propylene glycol, 2-3 butane diol, polyvinylpyrrolidone (PVP), proline (or other protein stabilizers) human serum albumin and combinations thereof. Suitable cryoprotectants structure
10 water which reduces the freezing point and/or reduces the rate of cooling necessary to achieve the vitreous phase. They also raise the glass transition temperature range of the vitreous state.

 The cryosolution may also include exposing the biological suspension to one
15 or more dry protectant compounds. Dry protectants, by definition, stabilize samples in the dry state. Some cryoprotectants also act as drying protectants. Some compounds possess variable amounts of each activity, e.g., trehalose is predominantly a dry protectant and a weaker cryoprotectant, whereas sucrose is predominantly a cryoprotectant and a weaker dry protectant. For example,
20 trehalose and polyhydroxyl carbohydrates bind to and stabilize macromolecules such as proteins and nucleic acids in a virus or vaccine sample when dried, thereby protecting the integrity of the sample. Various dry protectants can be used in the present invention: sucrose, raffinose, trehalose, zinc, proline (or other protein stabilizers), myristic acid (a known thermostabilizer of vaccines), spermine (a
25 polyanionic compound) and combinations thereof.

 Cryoprotectants, alone or in combination with other cryoprotectants or with additional components (for example, dry protectants) have also been found to be effective: proline plus sorbitol, trehalose plus zinc chloride, sorbitol plus myristic
30 acid, sorbitol plus trehalose, human serum albumin plus trehalose, sucrose plus raffinose, and human serum albumin plus sorbitol.

The cryoprotectants can be added to the biological samples for a period of a few minutes to a few hours before they are rapidly cooled. In general, cryopreservation is performed as a continuous sequence of events.

5 The inventors have been involved in the development of cryofixation and ultralow temperature molecular distillation drying as a method for preparing biological samples for electron microscopic analysis. To validate this approach, they investigated the relationship between the drying characteristics and ice phases present within frozen samples.

10

Sample preparation for electron microscopy by purely physical or dry processing techniques has theoretical appeal, especially when the ultimate aim is the analysis of both ultrastructure and biochemistry. Since the earliest days of electron microscopy, several attempts have been made to refine and develop freezing and vacuum drying or the freeze-drying (FD) process for cell and tissue samples.

15

Despite the conceptual advantages and the progress made, freeze-drying for electron microscopy has yet to achieve the status of a routine, broadly applicable technique. Several reasons account for this. First, the ultrastructural preservation is often inferior when compared to conventional chemical, or wet processing techniques or hybrid techniques such as freeze substitution. Second, there are numerous practical problems with sample manipulation, temperature control, vacuum parameters, and end processing protocols. Third, and perhaps most fundamentally, is a belief that drying at temperatures below -123°C is either impossible or impractical. As a result of these practical and theoretical obstacles, only sporadic investigation of low temperature freeze-drying has been reported.

20

25

The basis of this theoretical barrier comes from application of the kinetic gas theory and the predicted sublimation rates as expressed by the Knudsen equation:

$$J_s = N P_s \left(\frac{M}{2\pi Q T} \right)^{0.5}$$

5

where J_s = sublimation rate
 N = coefficient of evaporation
 P_s = saturation vapor pressure
 Q = universal gas constant
10 T = absolute temperature of the sample
 M = molecular weight of water.

15

For theoretically ideal drying conditions, this equation states that the sublimation rate is directly proportional to the saturation vapor pressure of water within the sample and inversely proportional to the absolute temperature of the sample. Although the temperature of the sample is clearly definable, saturation vapor pressure is a more complex parameter.

20

25

Prior applications of this equation have used saturation vapor pressures which were theoretically determined. These theoretical vapor pressures, however, include the latent heat of fusion, and hence, are applicable only to hexagonal ice. Calculations based on these theoretical values have led to conclusions such as "at 150K it would take 3.5 years until an ice layer of 1 mm thickness is completely removed by freeze drying. It is therefore unrealistic to attempt freeze drying at temperatures below 170K."

30

Several phases of ice other than hexagonal, however, can coexist within a sample depending upon the mode of cooling. These different phases can be achieved by several methods including; vapor condensation, hyperbaric application and ultrarapid quench cooling.

The major phases of ice now recognized are amorphous, cubic, and hexagonal. These ice phases exhibit different stabilities, which would suggest that the saturation vapor pressures would also be different. It has been determined that for vapor condensed water at temperatures where both phases can coexist, the saturation vapor pressure of amorphous ice is one to two logs higher than that of cubic ice.

Application of these experimentally determined saturation vapor pressures in the Knudsen equation reduces the drying time at 150K from 3.5 years to 0.035 years, or 12.7 days, for 1 mm of amorphous ice. Because quench cooling techniques of biological samples achieve approximately 5 μ m of this phase, the drying time of this component, based solely on the Knudsen equation, would be of the order of 1.5 hours. Hence, in terms of practical drying times, the theoretical barrier to drying at ultralow temperatures can be overcome.

Drying, however, is not a static, but a rate-dependent process. In addition to saturation vapor pressure of the different ice phases, one must also account for the rate of transition from one phase to another with increasing temperature. For electron microscopy sample preparation, drying should ideally occur without any such transition or devitrification. Information as to the rate of these transitions is limited. It has been found that the amorphous to cubic transition occurred as an irreversible process strongly dependent upon temperature in the range of -160°C to -130°C and expressed by

$$t = 2.04 \times 10^{28} \times \exp(-0.465T)$$

The cubic to hexagonal transition was less temperature-dependent, occurring in the range of -120°C to -65°C, and expressed by

$$t = 2.58 \times 10^{12} \times \exp(-0.126T)$$

Interestingly, when the sample temperature was increased at a rate of 5°C/minute, the amorphous to cubic transition occurred as a sudden event near -130°C.

5 Based upon the above data, the transition rate, as well as the saturation vapor pressure, determine the depth to which a particular ice phase can be dried at a specific temperature. For amorphous ice at -160°C, the transition time is 205 days. Based upon extrapolation of experimentally determined saturation vapor pressures and the Knudsen equation, this would allow drying of 26 microns. At 10 -140°C, transition time is 28 minutes and would allow drying of 0.8 μm under ideal conditions. Below -160°C, i.e., prior to the onset of the transition, one could predict little, if any, translational kinetic energy of the water molecules and hence little, if any, drying.

15 Based upon these considerations, one can postulate the hypothesis of transitional drying, i.e., that for a sample containing multiple phases of ice, it is possible to dry each phase sequentially during its transition. The amount of each phase dried will obviously be dependent upon multiple parameters including efficiency of drying apparatus, rate of heating, and impedance of the dry shell.

20 Cryopreservation

Cryopreservation is the preservation of cell structure and metabolism against injury associated with freezing events either within or around the cell. Natural cryoprotection can result from adaptive metabolism of the organism, with changes in cellular structure, composition and metabolic balance giving an enhanced 25 tolerance of freezing. In laboratory experiments when cell viability or ultrastructure are to be preserved following cooling, two methods are available. The first is to ultrarapidly cool the sample, resulting in the tissue fluids being vitrified, i.e., absence of ice crystals. The second is to incorporate chemical additives to confer a degree of cryoprotection. The chemicals range from naturally 30 occurring cryoprotectants such as glycerol, proline, sugars, and alcohols to organic

solvents such as dimethylsulfoxide (DMSO) to high molecular weight polymers such as polyvinylpyrrolidone (PVP), dextran and hydroxyethyl starch (HES).

5 Vitrifaction of cells and tissues is limited by the rate at which the sample can be cooled and the insulating properties of the tissue itself. Due to physical limitations, one can only achieve vitrification of a thin layer of tissues using state of the art techniques. This makes the idea of chemical additives for cryoprotection and manipulating the cooling rate very appealing in attempts to cool and store biological samples without causing structural and functional damage.

10

Injury to biological samples due to freezing is subject to fundamental physical and biological principles, some long known, but others only recently being understood. Serious investigations into the mechanisms of freezing injury in biological samples did not begin until the second quarter of this century. These early studies were dominated by the belief that physical damage by ice crystals was the principal cause of freeze injury. The effects of cell dehydration and a correlation between the concentration of extracellular solutes and cell death has been demonstrated. A "two factor" hypothesis for freezing injury proposed that cell injury was the result of either the concentration of solutes by extracellular ice or the formation of intracellular ice which caused mechanical injury.

15

20

The action of glycerol and other small polar compounds has been interpreted as penetrating and exerting colligative action within the cells. In the proportion that the colligative action of the penetrating compounds maintains water in the liquid state at temperatures below 0°C, an increased volume of cellular solution is maintained. This avoids an excessive concentration of toxic electrolytes in the nonfrozen cellular solution. A similar influence also takes place in the external solution. In this context, colligative action is referred to as action by an extraneous solute, in lowering the freezing point of the solution in contact with ice.

25

30

If enough protective compound is present, the salt concentration does not rise to a

critically damaging level until the temperature becomes so low that the damaging reactions are slow enough to be tolerated by the cells.

5 The nonpenetrating cryoprotectants vary in size from sucrose to large
polymeric substances such as PVP, HES and dextran. It has been suggested that
nonpenetrating substances act by some other means than that in the colligative
mechanism described above. The role of larger molecules is believed to be
dehydrative by osmotic action. When a large proportion of water is withdrawn
10 from the cells by means of an osmotic differential, less free water is available for
intracellular ice crystallization which is often identified as a lethal factor.

The cooling rate in the presence of cryoprotective compounds is a very
important factor in freezing injury. Normally, slow cooling is better than elevated
cooling rates since the latter promotes intracellular ice formation. This occurs
15 because there is insufficient time for water to escape from the cells before the
contained cell water freezes. With slow rate cooling, extracellular ice forms first,
resulting in dehydration of the cell which, together with the presence of the
cryoprotectant, prevents intracellular ice formation.

20 Penetrating compounds were thought to act by not allowing an excessive
transport of water from the cells too early in the freezing process while
nonpenetrating compounds have a dehydrative effect on cells along with a
colligative effect of diluting the solution surrounding the cell. Neither of these
descriptions, however, tells the whole story.

25 When cells were exposed to glycerol or DMSO for very short times, during
which presumably little penetration would occur, they still exhibited cryoprotection.
Red blood cells exposed to DMSO, glycerol or sucrose for 30 seconds to 2 hours
at 0°C demonstrated the same degree of cryoprotection.

30

Solutes such as HES and PVP are totally nonpenetrating, water withdrawing compounds of merely larger molecular weight than nonpenetrating sucrose. The larger molecular weight should render such compounds less osmotically and colligatively effective, when considered on a weight basis. Yet in concentrated solutions, the compounds' colligative action has been shown to be far greater than would be expected based on merely a linear relationship to concentration.

Cryoprotective properties result from a multiplicity of actions including: (1) coating of membranes by polymeric compounds so that they are not denatured by the increased salt concentration resulting from freezing, (2) alteration of membrane permeability characteristics so that they leak solutes reversibly to avoid excessive dehydration, (3) increasing viscosity and thus slowing the speed of transfer of water, (5) preventing denaturation of serum lipoproteins during low temperature freezing and drying, (6) diminished activity of several enzyme systems, and (7) membrane protein stabilization.

A source of damage to frozen tissue, other than freezing itself, is the osmotic and toxic effects of many of the cryoprotective agents. When used in mixtures, some cryoprotective compounds may counteract the toxicity of other cryoprotectants, as was demonstrated by the addition of polyethylene glycol (PEG) to a mixture of DMSO and glycerol. The inventors have developed a vitrification solution (VS) comprising a mixture of:

25	DMSO	-	0.5M
	Propylene glycol	-	0.5M
	2-3 butanediol	-	0.25M
	Proline	-	1.0M
	Raffinose	-	2.5% (w/v)
	PVP	-	15% (w/v) (Ave. M.W. \approx 40,000)
30	Dextran	-	15% (w/v) (Ave. M.W. \approx 40,000-70,000)

The toxicity of the individual components of this solution were tested. In the above mixture, the toxic effects were lower than when the same concentration

of any one component was used alone. This resulting solution is nontoxic to cell cultures and remains glass like and optically clear (i.e., no visible ice crystal is formed) when plunged into liquid nitrogen.

5 A modified vitrification solution (VS_1) has also been developed which comprises a mixture of:

	DMSO	-	0.5M
	Propylene glycol	-	0.5M
10	2-3 butanediol	-	0.25M
	Raffinose	-	10% (w/v)
	Trehalose	-	6% (w/v)
	Sucrose	-	6% (w/v)
	PVP	-	12% (w/v) (Ave. M.W. \approx 40,000)
15	Dextran	-	12% (w/v) (Ave. M.W. \approx 40,000-70,000)

Another modified vitrification solution (VS_2) which has been developed comprises a mixture of:

20	DMSO	-	0.5M
	Propylene glycol	-	0.5M
	2-3 butanediol	-	0.25M
	Raffinose	-	2.5% (w/v)
	Sucrose	-	12% (w/v)
25	PVP	-	15% (w/v) (Ave. M.W. \approx 40,000)
	Dextran	-	15% (w/v) (Ave. M.W. \approx 40,000-70,000)

In summary, the factors affecting the cryoprotective nature of compounds are (a) chemical nature, (b) relative lack of toxicity, (c) molecular size and penetrating ability, and (d) interaction with other compounds in the mixture.

The physicochemical effects of cryoprotectants are (a) depression of the equilibrium freezing point of substrate and cytoplasm on a colligative basis, (b) depression of homogeneous ice nucleation temperature, (c) reduced rate of ice crystal growth due to change in the viscosity and thermal diffusivity of the solution, and (d) dehydrative effects on cells by osmotic action.

Cooling Parameters

For purposes of cryopreparation of the biological suspensions of this invention, it is essential to note that a variety of cooling processes can be used. In a preferred embodiment of this invention, rapid cooling is considered essential to obtain the proper ice crystal blend. In the most preferred embodiment of this invention, a vitrification procedure is used which results in the formation of a substantial proportion of amorphous water in the biological sample. As will be disclosed hereinafter, regardless of the form of cooling that is used, it is believed that amorphous phase water, cubic ice crystals and hexagonal ice crystals are present in the final product. The method of cooling has a distinct bearing on the distribution of ice crystal types found in the cooled cryosolution.

Drying Parameters

The aim of controlled drying of a frozen biological sample by molecular distillation drying is to remove water from the sample without further mechanical or chemical damage occurring during the drying process. This involves avoiding, by use of appropriate drying conditions, two fundamental damaging events. The first is to remove water from ice crystalline phases without transition to larger more stable and more destructive crystals. The second is to remove water from solid but noncrystalline water or water-solute mixtures without melting or crystallization of these solid phases. This second component refers to water present in the amorphous condition, water together with solute in the eutectic or water together with a compound which binds and structures water and hence, prevents its crystallization during the freezing process. Hence, vitreous water can be of low energy and stability, as in ultrarapidly-cooled pure water, or high energy and stability, as that achieved with cryoprotective agents with intermediate rates of cooling.

Many of the features required of controlled drying to avoid the occurrence of these events are overlapping. The reason for this is that each form of water will have a particular energy state, whether in a crystal or bound to a cryoprotective

compound, and it is this energy state, rather than its configuration, which determines the requirements for drying. Consider for example, (1) a sample of cubic ice achieved by cooling pure water at an intermediate cooling rate and (2) vitrified water achieved by mixing water with glycerol to 45% vol:vol and cooling at an intermediate rate. The first sample will be crystalline and the aim of drying is to remove water from this state without transition to hexagonal ice. The second sample is an amorphous solid and the aim of drying is to remove water from this phase without melting of the glass to a liquid with subsequent boiling. For cubic ice, the onset of its transition is -130°C and the rate of transition is temperature dependent being very slow at -130°C and very rapid at -90°C . For 45% glycerol-water, the glass transition temperature is -120°C and represents the onset of melting. The melting process is very slow at -120°C and is temperature dependent, becoming very rapid at -90°C .

Prior to the onset of the cubic to hexagonal transition or the glass transition of 45% glycerol-water, the saturation vapor pressure of water in these phases is extremely low and drying would occur at extremely slow rates. The aim of controlled drying, therefore, is to remove water from the cubic ice phase during its transition and in a time less than is required for any significant transition to hexagonal ice and from the 45% glycerol-water phase during its transition to a liquid but in less time than is required for any appreciable liquid to form.

This argument can be applied repetitively to all forms of water present whether it be crystalline in the form of cubic or hexagonal or noncrystalline as amorphous or bound to any molecule, be it cryoprotectant, protein, carbohydrate, or lipid. To simplify this concept, water in a frozen biological sample can be described as having a specific energy level E . In a frozen biological sample, there will be water forms of multiple definable energy levels:

$$E_1 \quad E_2 \quad E_3 \quad \text{----} \quad E_n$$

The mode of preparation, the nature of the sample, the use of cryoprotectants or other additives, and the cooling rate used will determine the relative proportions of

these different water forms. Each energy level will determine the onset temperature of its transition or melting and the temperature dependence of the rate of the transition or melt.

5 Controlled drying processes must be able to remove each of these different states of water during the transition and in less time than is required to complete the transition. This mode of drying, therefore, requires that several conditions be met.

10 First, the sample must be loaded into the dryer without temperature elevation above its lowest transition temperature. If elevation of temperature does occur, this must be over a short period of time such that no appreciable transition occurs. Ideally, loading occurs under liquid nitrogen at -190°C , well below the lowest discernible transition of -160°C for pure, ultrarapidly-cooled amorphous
15 water. If, however, the sample is predominantly cubic ice or a mixture of water and cryoprotectants with a glass transition of the order of -100°C to -130°C , a closed circuit refrigeration system may be sufficient to enable maintenance of the sample temperature below the onset of transition.

20 Once loaded, the sample must be exposed to vacuum and be in direct line of sight of the condenser surfaces. The criteria for these are again determined by the nature of the water phases present in the sample. The following objectives must be attained. The vacuum within the chamber during the drying of a particular phase must create a partial pressure of water at least equivalent to or less than the
25 saturation vapor pressure of water in the phase to be removed. This saturation vapor pressure is dependent on the nature of the water phase and its temperature. Hence, for pure amorphous water in the transition range of -160°C to -130°C , the approximate saturation vapor pressures are 6×10^{-12} mbar (-160°C) and 5×10^{-7} mbar (-130°C), respectively. As the transition times of amorphous to cubic ice in
30 this same temperature range, -160°C to -130°C , vary from 5×10^5 minutes to 5 minutes, drying will be very slow until temperatures of the order of -150°C to -

140°C are reached requiring a vacuum of 5×10^{-10} to 2×10^{-8} mbar. This represents one extreme.

5 For cubic ice, little if any drying will occur below its onset of transition at -
130°C as its saturation vapor pressure will be of the order of one log lower than
for amorphous water. In the transition range, -130°C to -100°C, the saturation
vapor pressure of cubic ice is approximately 5×10^{-8} to 9×10^{-5} mbar. The
transition times of cubic to hexagonal are 700 minutes and 109 minutes
respectively. The saturation vapor pressure, therefore, determines the vacuum
10 requirements for drying and can be applied to all water phases present. It is
important to note that the same vacuum criteria are not applicable to all phases, but
rather are phase-dependent.

15 A second criteria of the vacuum is that the mean free path created be in
excess of the distance between the sample and the condenser surface. Ideally, this
should be a tenfold excess. The condenser surface must be a lower temperature
than the onset transition temperature of the phase of water being removed from the
sample so that the saturation vapor pressure of water condensed on this surface
during drying is considerably lower than that of the water phase within the sample.
20 Ideally, this should be three orders of magnitude lower. For a sample containing
multiple water phases, the temperature of the condenser surface must remain below
the onset of transition of the least stable ice phase remaining to be removed.
Ideally, the condenser should also be in line of sight of the sample.

25 Once the sample has been loaded and exposed to vacuum and the condenser
surfaces, the sample and sample holder must be heated so as to increase the
mobility of water molecules and hence, cause their escape. This is the essential
and critical component in the drying of a sample containing multiple phases or
energy levels of water. The temperature of the sample must be accurately known.
30 The control of temperature and the rate of sample heating must be accurately

controlled. This is necessary to ensure that the drying of each phase of water in the sample is sequential.

Hence, for a sample containing multiple phases of water of energy level E_1 , and E_2 ---- E_n where E_1 is the least stable, then heating must occur at such a rate that E_1 is removed prior to its transition to E_2 . E_2 prior to its transition to E_3 and so on. This requires nonequilibrium drying conditions and heating at a continuous rate or by holding at a constant temperature level such that sublimation occurs as determined by:

10

$$Js = NPs \left(\frac{M}{2\pi QT} \right)^{0.5}$$

- where Js = sublimation rate in $g\ cm^{-1}\ sec^{-1}$
- N = coefficient of evaporation
- Ps = saturation vapor pressure
- M = molecular weight of water
- Q = universal gas constant
- T = absolute temperature of the sample.

15

This is consistent with the transition rate for the particular phase being removed. For example, the rate of the amorphous to cubic transition is given by:

20

$$E = 2.04 \times 10^{28} \times \exp(-0.465T)$$

25

Alternatively, if the transition window is T_1 to T_2 , the sublimation rate and the transition rate will vary with temperature during this interval. The rate of heating during this window T_1 to T_2 must be such that sublimation occurs

throughout the dimensions of the sample before transition at any particular temperature is completed.

5 In this way, the aim of controlled drying is achieved, i.e., the sequential removal of each phase of water under conditions appropriate to the properties of each phase without appreciable ice crystal growth, formation or melting of the particular phase. Once dry, the sample must be physically or mechanically isolated from water on the condenser surface or any other source and stored in a closed container either under vacuum or dry inert gas.

10

In a preferred embodiment, samples are cooled by an appropriate method such that ice crystal formation is below the degree that would cause damage to the sample. Once frozen, the sample is then stored below the transition temperature of the most unstable ice form. For amorphous ice, this is preferentially below -
15 160°C. The sample is then loaded into a sample holder, precooled to -196°C and transferred into a molecular distillation dryer. The dryer chamber is then closed and sealed for vacuum integrity. To avoid recrystallization, the hydrated sample must remain below the transition temperature of the most unstable ice form throughout all manipulations.

20

Once the sample is loaded, high vacuum (10^{-8} to 10^{-6} mbar) is generated inside the chamber. The sample is placed considerably closer to the condenser surface (LN₂ cooled chamber walls) than the mean free path within the chamber. The condenser temperature must always be below that of the sample. For an
25 amorphous sample, the condenser is preferentially -196°C.

The sample holder is then heated via a programmable heater microprocessor thermocouple loop. Heating programs are determined according to the nature of the sample. A typical program for a sample containing amorphous, cubic and
30 hexagonal ice is 10°C per hour from -180°C to -150°C, 1°C per hour from -150°C to -70°C, and 10°C per hour from -70°C to +20°C.

Once the sample has reached 20°C, it can be sealed inside an appropriate container within the vacuum chamber and unloaded for subsequent storage. In one configuration, the sample is contained within a glass vial and sealed with a butylrubber lyophilization stopper at the end of cycle. More specific details of the operation of the molecular distillation dryer are given in U.S. Patent No. 4,865,871.

Reconstitution

The freezing and drying of biological substances impart great physical stress upon the bonding forces which normally stabilize macromolecular conformation. Contributing to this destabilizing effect is the increase in concentration of electrolytes and possible pH changes as the solution freezes. As a consequence, modifications to the sample, including the dissolution of membrane structures, the inactivation of certain enzymes, and the denaturation of proteins, may result.

Studies with lactic dehydrogenase have shown that freezing and thawing cause dissociation of the tetrameric enzyme into subunits which is accompanied by a change in biological activity. The dissociation was found to be dependent on the ionic strength and pH during freezing.

Other studies investigating the quaternary structure of L-asparaginase demonstrated that this enzyme dissociated from the active tetramer to inactive monomers when freeze-dried. This monomeric state was found to be stabilized by reconstitution of the dried enzyme with buffers of high pH and high ionic strength. However, the dissociation was shown to be completely reversible on reconstitution at neutral pH and low ionic strength. The effect of pH on the other hand may induce changes in the three dimensional structure resulting in subunits conformationally restrained from reassociation.

These studies indicate the importance of determining optimal pH and ionic strength conditions of not only the formulation used in the cryopreservation

protocol, but also the reconstitution solution. In this way, maximal sample activity and stability may be obtained.

5 Other variables of reconstitution such as vapor phase rehydration or
temperature may also be important to the retention of activity following freezing
and drying. Other workers in the field have demonstrated a marked difference in
proliferative response to lectins depending on the temperature of rehydration or
whether samples were reconstituted by vapor phase. Improved responses to lectins
were noted when the freeze-dried lymphocytes were rehydrated at dry ice
10 temperatures and then allowed to warm. This gradual method of reconstitution
reduced the osmotic stress induced by sudden rehydration.

Storage Considerations

15 Sublimation of water from a frozen sample has been an excellent method for
preserving the active components of biological material. However, the optimal
preservation of activity with long-term stability requires critical control of the
drying process and storage conditions. Following the removal of free or unbound
sample water, the process of secondary drying proceeds in which structurally
bound water is removed. Bound water is intimately associated with the maintenance
20 of protein conformation. Thus, the amount of water remaining in the dried sample,
known as the residual moisture content, is a significant variable in the drying
process, as it affects both the survival and stability of the sample.

25 Residual moisture content is expressed as the "percentage residual moisture"
and is equated to the weight (gm) of residual water per unit weight (gm) of original
sample.

30 It is generally agreed that biological materials dried by vacuum sublimation
of ice show increased stabilization when dried to optimum contents of residual
moisture. Materials which have been under or overdried, i.e., to moisture contents
that are above or below the optimum, will show increased deterioration.

5 Although the optimal residual moisture content will vary depending on the particular dried sample, certain stability problems can be expected when the levels of moisture are suboptimal. Overdrying a sample, i.e., residual moisture contents less than 1-2% without using a dry stabilizer, generally results in removal of nearly all structured water allowing saturation or blocking of exposed hydrophilic sites of proteins by oxidation. This oxidation causes degradation with a corresponding decrease in the biological activity. On the other hand, residual moisture contents of greater than 5% generally are indicative of underdrying where sufficient amounts of "free water" remain in the sample which could contribute to transconformation of the protein. The resulting rearrangements of the polypeptide chains shift from the typical ordered arrangement of the native protein to a more disordered arrangement. These protein perturbations can result in poor long-term stability of the dried product.

15 Successful long-term storage requires sample drying to optimal levels of residual moisture. Inadequate drying of biological samples and its consequences have been shown in the literature. Maximal stability of suspensions of influenza virus dried by sublimation of water in vacuo occurred at a residual moisture content of approximately 1.7%. Under or over drying to sub-optimal water content resulted in the degradation of the virus suggesting that varying amounts of free and bound water in a dried sample have an effect upon protein structure and activity.

25 To maximize sample stability and satisfy regulatory requirements for the preparation of dried pharmaceuticals or reagents, it is essential that the residual moisture content be determined following sample drying.

Several methods are available to measure residual moisture contents;

1. Gravimetric (Heating Method) - A known quantity of dried product is heated and the weight loss can be equated with water content.

2. Chemical Assay - This method is based on the reaction between water and free iodine in a mixture of pyridine, sulphur dioxide and methanol. The endpoint is detected coulometrically when free iodine is present.
$$\text{H}_2\text{O} + \text{I}_2 + \text{SO}_2 + \text{ROH} + 3\text{RN} \rightarrow 2\text{RNHI} + \text{RN} + \text{HSO}_4\text{R}$$
3. Gas Chromatography

Each of the methods has limitations and therefore, it is wise to not rely on any single method of moisture determination. Rather, multiple methods should be employed to validate the results.

Once dried to optimal residual moisture contents, the sample is still considered unstable when removed from the vacuum due to its hygroscopic nature and susceptibility to oxidation. Measures must be taken during storage to protect the sample from atmospheric rehydration and minimize exposure to oxygen. Such protection is essential to the maintenance of the sample's long-term stability.

Evidence in the literature indicates that the gaseous condition under which the samples are sealed, as well as the storage temperature, effects the long-term stability of the sample. It has been demonstrated in a study comparing different gases and storage temperatures, that maximum stability of influenza virus was obtained when samples were stored under helium or hydrogen gas at low temperature (-20°C). Sealing under other gases or vacuum at different storage temperatures resulted in varying levels of stability. The inventors postulate that those conditions which most effectively limit oxygen contact with the sample, markedly improve biological activity by reducing oxidation of exposed hydrophilic sites at the protein surface. Appropriate storage parameters, i.e., temperature, and sealing under gas or vacuum are important to obtain long-term sample stability.

Protectants

Cryopreservation is accomplished by a combination of cryoprotectant and optimum cooling rate. The aim is to minimize the concentration of cryoprotectant required, and therefore its toxicity, and to also minimize the rate of cooling required to achieve the appropriate ice phases in the sample.

Although activity in the development of the process of this invention has been primarily directed to the cryopreservation and dry stabilization of biological samples such as viruses, cultured cells and erythrocytes, the process is not so limited. Some of the cryoprotectants and dry protectants that have been used successfully in the method of this invention and which allow the retention of biological activity following cooling and drying are described in the following examples:

EXAMPLE 1Preservation and Storage of Mammalian Cultured Cells

1. NCTC 929 cells were resuspended in LISP at 2.5×10^5 cells/ml.
2. The cells were then nebulized with an ultrasonic nebulizer (25 kHz nozzle) at 1.5 watts, 6 ml/min flow rate, resulting in microdroplets having diameters of about 200 μm and cooled to a temperature below -160°C , using the device described above.
3. Approximately 2 ml aliquots of the cells (based on initial liquid volume) were collected and placed in glass vials, and were then dried in a molecular distillation dryer.
4. Following drying, the vials were sealed under vacuum in the dryer and the vacuum was reversed with dry nitrogen gas.

5. Following storage at 4°C for 3 days, a vial was opened under ambient conditions and the dry cells were transferred into a cell culture dish containing 250 μ l of a vitrification solution (VS₁) comprised of:

5	DMSO	- 0.5 M
	Propylene glycol	- 0.5 M
	2-3 butanediol	- 0.25 M
	Raffinose	- 10% (w/v)
	Trehalose	- 6% (w/v)
10	Sucrose	- 6% (w/v)
	PVP (Av. M.W. - 40,000)	- 12% (w/v)
	Dextran (Av. M.W. - 70,000)	- 12% (w/v)

6. The vitrification solution was then diluted in steps at 10 minute intervals by adding normal cell culture medium. Each addition of medium resulted in the vitrification solution being diluted to the following concentrations: 70%, 50%, 25%, 12.5% and 1.25%.
7. After the final dilution, the culture dish was transferred to a 37°C, 5% CO₂ incubator and left undisturbed for 2 weeks.

Results: Following full processing, including nebulization, rapid freezing, molecular distillation drying, and rehydration, the cultured cells showed an intact electron microscopic appearance with distinct cytoplasm and nucleus and defined cellular organelles. Selected cells showed trypan blue exclusion and fluoresce green with acridine orange and propidium iodide. Eleven colonies grew from the rehydrated cells.

EXAMPLE 2

Preservation and Storage of Mammalian Cultured Cells

- 5 1. NCTC 929 cells were resuspended in LISP and 1% glycerol at 2.5×10^5 cells/ml. The cells were then incubated at room temperature for 20 minutes, cooled on ice for 20 minutes, spun down in a refrigerated centrifuge (4°C, 5 min, 1000 rpm), aspirated to remove the supernatant and resuspended to the original volume in cold (4°C) LISP buffer.
- 10 2. The cell suspension was then nebulized with a 25 kHz nozzle set at 1.5 watts with a flow rate of 6 ml/min using the modified Sonotek device described above.
- 15 3. The nebulized microdroplets were frozen in the microdroplet cryofixation device described in the specification.
4. The frozen microdroplets were collected and dried in a Virtis bench top freeze dryer which had been modified by placing a -80°C condenser surface near the sample.
- 20 5. The dry cells were sealed under vacuum, unloaded from the dryer and stored at 4°C for 3 days.
- 25 6. A dry sample vial was allowed to come to room temperature and half of the sample were rehydrated in 250 μ l of each of the following:
 - a. 25% dextran (mol. wt. 480,000) in 0.2 M Tris-HCl, pH 8.3.
 - b. Saturated mannitol in 0.2 M Tris-HCl, pH 8.3.
- 30 7. The cells were then diluted 8 fold in 4 steps with NCTC 135 medium with 10% horse serum and standard tissue culture concentrations of penicillin and streptomycin.

8. Half of each suspension was then plated on a petri dish while the other half was spun down, resuspended in NCTC 135 medium with 10% horse serum, penicillin and streptomycin, and then plated.
- 5 9. Cell growth was evaluated by counting colonies 2 weeks later.
10. From the approximately 2.5×10^5 cells, 13 total colonies were generated:
- 10 a. 1 colony from the sample rehydrated in dextran and then plated;
- b. 4 colonies from the sample rehydrated in dextran, resuspended in NCTC 135 medium and then plated;
- c. 8 colonies from the sample rehydrated in mannitol and then plated; and
- d. no colonies from the last sample which became contaminated during processing.
- 15

EXAMPLE 3

Preservation and Storage of Mammalian Cultured Cells

1. NCTC 929 cells were resuspended in LISP and 1% horse serum at 2.5×10^5 cells/ml.
- 20
2. The cell suspension was then nebulized with a 25 kHz nozzle set at 1.5 watts with a flow rate of 6 ml/min using the modified Sonotek device described above.
- 25
3. The nebulized microdroplets were frozen in the microdroplet cryofixation device described in the specification.
4. The frozen microdroplets were collected and dried in a Virtis bench top freeze dryer which had been modified by placing a -80°C condenser surface near the sample.
- 30

5. The dry cells were sealed under vacuum, unloaded from the dryer and stored at 4°C for 3 days.
- 5 6. A dry sample vial was allowed to come to room temperature and rehydrated in 250 μ l of a 1:1 mixture of 25% dextran (M.W. 480,000) and saturated mannitol in 0.2 M Tris-HCl, pH 8.3.
- 10 7. The cells were then diluted 8 fold in 4 steps with NCTC 135 medium with 10% horse serum and standard tissue culture concentrations of penicillin and streptomycin.
- 15 8. Approximately half of the cells were then plated on a petri dish while the other half was spun down, resuspended in NCTC 135 medium with streptomycin, then plated.
9. Cell growth was evaluated by counting colonies 2 weeks later.
- 20 10. From the approximately 2.5×10^5 cells, 80 total colonies were generated, 40 from each of the suspensions.

EXAMPLE 4

Preservation and Storage of Human Erythrocytes

25 Fresh human erythrocytes were obtained by venipuncture and collected in ACD anticoagulant in the ratio of 1:10 with whole blood. The blood sample was then centrifuged at 2000 g for 10 minutes and the supernatant removed.

30 The packed red cell sample was then diluted to a 5-10% hematocrit using a buffer (Adsol) consisting of 2.2% dextrose, glucose, 0.9% sodium chloride, 0.75% mannitol and 0.027% adenine.

Once obtained and isolated, the following steps were employed to preserve and store the erythrocyte sample.

- 5 1. The erythrocyte suspension was prepared as three cryosolutions which consisted of the following:
 - 10 a. cells added to buffer alone.
 - 15 b. cells which were pretreated at 22°C with one percent glycerol. Following a 20 minute incubation, the cells were cooled to 4°C on ice. When the cells had equilibrated to 4°C, they were centrifuged at 4°C for 10 minutes at 2000 g. The supernatant was then removed and the cells resuspended in a 4°C solution consisting of 1% dextran (average MW 40,000-70,000) in buffer, to a final hematocrit of 5-10%.
 - 20 c. cells which were treated with a 5% vitrification solution (VS₁ discussed above, diluted 20:1) composed of 0.025M dimethylsulfoxide, 0.025M propylene glycol, 0.0125M 2-3 butane diol, 0.5% raffinose, 0.3% trehalose, 0.3% sucrose, 0.6% polyvinylpyrrolidone and 0.6% dextran.
- 25 2. The cryosolutions were then nebulized at a flow rate of 6 mls per minute using the ultrasonic nebulizer described above at 1.5 - 2.5 watts and 25-60 kHz.
- 30 3. The nebulized cryosolution was rapidly frozen without contact with liquid cryogen using the internally cooled cryogenic surface described above.
4. The frozen sample was then collected and stored at temperatures below -160°C.

5. The erythrocyte samples were then dried by molecular distillation drying employing the methods described in U.S. Patent No. 4,865,871.
- 5 6. The erythrocyte samples were stored under vacuum for up to 2 weeks.
7. The erythrocyte samples were then rehydrated by the addition of either:
- 10 a. Adsol buffer;
or
b. 40% dextran in buffer and serially diluted to 5% dextran in 6 steps by the addition of buffer. The erythrocyte sample was then centrifuged at 2000 g for 10 minutes and resuspended in
15 buffer.
8. The erythrocyte samples were then assessed for morphology using phase contrast microscopy.
- 20 9. After storage and assay evaluations, the effectiveness of the various protocols were evaluated with the following results:
- | | | |
|----|---------------|----------------------------------|
| 25 | Cryosolution: | Adsol |
| | Rehydration: | Adsol |
| | Morphology: | 90% small cells, 10% ghost cells |
| | Cryosolution: | Adsol |
| | Rehydration: | 40% Dextran |
| | Morphology: | 100% intermediate cells |
| 30 | Cryosolution: | 5% VS ₁ |
| | Rehydration: | Adsol |
| | Morphology: | 20% small cells, 80% ghost cells |

5	Cryosolution:	5% VS ₁
	Rehydration:	40% Dextran
	Morphology:	20% small cells, 30% intermediate cells, 40% large cells and 10% ghost cells
10	Cryosolution:	1% intracellular glycerol, 1% extracellular Dextran
	Rehydration:	Adsol
	Morphology:	50% small cells, 45% intermediate cells, 5% ghost cells
15	Cryosolution:	1% intracellular glycerol, 1% extracellular Dextran
	Rehydration:	40% Dextran
	Morphology:	5% small cells, 95% intermediate cells

EXAMPLE 5

Preservation and Storage of Oral Polio Vaccine (OPV)

20 Oral polio vaccine (OPV) is composed of three serotypes of live but attenuated poliomyelitis virus. It is one of the two commonly used vaccines for the prevention and treatment of the crippling disease of poliovirus. Methods for obtaining and isolating live, attenuated polio virus are known to those skilled in the art of virology.

25 The effectiveness of the present invention was demonstrated by the following experiments:

- 30 1. A trivalent preparation of oral polio vaccine (OPV) was obtained from the manufacturer and stored at -80°C.
2. Immediately prior to processing, the preparation was thawed in a 37°C water bath. The preparation was then desalted by ultrafiltration using a stirred cell device.

3. The desalted OPV samples were then resuspended in the following solutions until fully suspended to form a cryosolution and allowed to incubate at room temperature for 30 minutes.
 - a. 1M MES buffer alone, pH 8.5
 - b. 1M Tris buffer alone, pH 8.5
 - c. 250mM Trehalose in 1M Tris buffer, pH 8.5
4. Following incubation, the cryosolutions were rapidly frozen using the nebulizing device previously described. For each of the cryosolutions, 500 μ l of nebulized sample was collected into small, (5 cc) freeze drying vials maintained at cryogenic temperatures. Butyl rubber lyophilization stoppers were placed in the openings of the vials.
5. The nebulized samples were then placed into a liquid nitrogen cooled sample holder and loaded into a molecular distillation dryer and dried by molecular distillation drying.
6. Upon reaching 20°C, the vials were sealed within the dryer under vacuum.
7. The dried samples were removed from the dryer and stored at room temperature for approximately two weeks before being assayed.
8. At the time of assay, the OPV samples were reconstituted with 500 μ l of distilled water by injection through the lyophilization stopper.
9. The OPV samples were assayed for viral titers of each serotype utilizing standard methods.

10. After assay evaluations, the effectiveness with respect to viral activity was assessed in duplicate and expressed as TCD₅₀.

<u>Cryosolution</u>	<u>Serotype I</u>	<u>Serotype II</u>	<u>Serotype III</u>
MES buffer alone	4.45	4.45	4.45
Tris buffer alone	5.41	4.94	6.08
250mM Trehalose in Tris buffer	4.87	4.60	4.59
Control	7.02	6.18	7.13

15 * * *

20 Although the preferred embodiment of the apparatus used in the practice of this invention has been described hereinabove in some detail, it should be appreciated that a variety of embodiments will be readily apparent to a person designing cryopreparation apparatus for a specific end use. The description of the apparatus of this invention is not intended to be limiting on this invention, but is merely illustrative of the preferred embodiment.

25 While the compositions and methods for sample preservation and storage have been described in terms of preferred embodiments, it will be apparent to those of skill in the art that variations and modifications may be applied to the composition, methods and in the steps or in the sequence of steps of the methods described herein without departing from the concept, spirit and scope of the invention. More specifically, it will be apparent that certain agents which are both chemically and physiologically related may be substituted for the agents described herein such that the same or similar results would be achieved. The examples
30 presented above describe methods for preserving and storing microscopic biological materials in suspension. Substitutes and modifications apparent to those skilled in the art are deemed to be within the spirit, scope and concept of this invention as defined by the appended claims.

- 44 -

The embodiments of the invention in which an exclusive property or privilege is claimed are defined as follows:

1. A method for preserving a suspension of biological material comprising:

(a) preparing a cryosolution of a suspension of biological material, said cryosolution comprising a buffer, a cryoprotectant and a biological material;

(b) nebulizing said cryosolution with a low frequency, ultrasonic nebulizer to form microdroplets;

(c) cooling the microdroplets at a rate which results in the formation of amorphous phase ice and/or cubic phase ice with or without hexagonal phase ice in said cryosolution by spraying the microdroplets on a solid cryogenic surface;

(d) continuously removing said cryosolution from said solid cryogenic surface after cooling to replenish said surface for further cooling of additional microdroplets; and

(e) drying the cooled cryosolution to form a dried cryosolution.

2. The method of claim 1 wherein said dried cryosolution has a final residual moisture content of less than about 5%.

3. The method of claim 1 wherein said cryosolution further comprises a dry protectant.

- 45 -

4. The method of claim 2 further comprising the step of sealing said dried cryosolution in a container without increasing the residual water content of said dried cryosolution above about 5%.

5. The method of claim 4 wherein said sealing is under low pressure or in the presence of a dry inert gas.

6. The method of claim 1 wherein said buffer is selected from the group consisting of 2-amino-2-hydroxymethyl-1,3-propanediol; 2-ethanesulfonic acid; 2-amino-2-methyl-1,3-propanediol; 3-propanesulfonic acid; piperazine-N-N'-bis; 1,4-piperazinediethanesulfonic acid and combinations thereof.

7. The method of claim 1 wherein said buffer is a low salt buffer mixture selected from the group consisting of:

(1) 8 gms glycine, 20 mls of 0.15M phosphate buffer pH 6.7-8.4 and 1.8 gm sodium chloride made up to 1000 ml., pH 6.7;

(2) 16 gms glycine, 20 mls of 0.15M phosphate buffer pH 6.7-8.4, 1.8 gm sodium chloride, 5.0 gms glucose, 0.06 gm calcium chloride and 0.1 gms adenine made up to 1000 ml., pH 6.7;

(3) a solution containing 0.9% NaCl, 0.75% mannitol, 2.2% dextrose and 0.027% adenine;

(4) a solution containing 0.875% dextrose, 0.9% NaCl, 0.214% mannitol, 0.008% adenine, 0.2555% sodium citrate, 0.029% citric acid and 0.022% monobasic sodium phosphate;

- 46 -

(5) 16 mM phosphate buffer, pH 7.4, 5 mM KCl, 4 g/dl BSA and 6.9 g/lit. lactose; and

(6) 16 mM phosphate buffer, pH 7.4, 5 mM KCl and 15 g/lit. lactose.

8. The method of claim 1 wherein said cryoprotectant is selected from the group consisting of dimethyl sulfoxide, 2-3 butane diol, polyvinylpyrrolidone, propylene glycol, 1,2 propanediol, glycerol, fructose, trehalose, raffinose, hydroxyethyl starch, dextran, sucrose, sorbitol, proline, human serum albumin and combinations thereof.

9. The method of claim 8 wherein said cryoprotectant is selected from the group consisting of:

(1) a vitrification solution comprising a mixture of 0.5M DMSO, 0.5M propylene glycol, 0.25M 2-3 butanediol, 1.0M proline, 2.5% raffinose, 15% PVP with an average molecular weight of about 40,000 and 15% dextran with an average molecular weight from about 40,000 to about 70,000;

(2) a vitrification solution comprising a mixture of 0.5M DMSO, 0.5M propylene glycol, 0.25M 2-3 butanediol, 10% raffinose, 6% trehalose, 6% sucrose, 12% PVP with an average molecular weight of about 40,000 and 12% dextran with an average molecular weight from about 40,000 to about 70,000; and

(3) a vitrification solution comprising a mixture 0.5M DMSO, 0.5M propylene glycol, 0.25M 2-3 butanediol, 2.5% raffinose, 12% sucrose, 15% PVP with an average molecular weight of about 40,000 and 15% dextran with an average molecular weight from about 40,000 to

- 47 -

about 70,000.

10. The method of claim 3 wherein said dry protectant is selected from the group consisting of: sucrose, raffinose, trehalose, zinc, proline, myristic acid, spermine and combinations thereof.

11. The method of claim 1 wherein said drying comprises freeze drying.

12. The method of claim 1 wherein said drying comprises molecular distillation drying.

13. The method of claim 1 wherein said biological material comprises red blood cells.

14. The method of claim 1 wherein said biological material comprises mammalian cultured cells.

15. The method of claim 1 wherein said biological material comprises platelets.

16. The method of claim 1 wherein said biological material comprises leukocytes.

- 48 -

17. The method of claim 1 wherein said biological material comprises Factor VIII.

18. The method of claim 1 wherein said biological material comprises sperm.

19. The method of claim 1 wherein said biological material comprises pancreatic islets.

20. The method of claim 1 wherein said biological material comprises bone marrow cells.

21. The method of claim 1 wherein said biological material comprises a virus.

22. The method of claim 1 wherein said biological material comprises a vaccine.

23. The method of claim 1 further comprising rehydrating the dried cryosolution.

24. A method for preserving a suspension of a microscopic biological material comprising:

(a) preparing a cryosolution of a microscopic biological material,

- 49 -

said cryosolution comprising a buffer, a cryoprotectant, and a biological material;

(b) nebulizing said cryosolution with a low frequency, ultrasonic nebulizer to form discrete droplets, said droplets being less than about 200 μm in diameter;

(c) rapidly cooling said droplets resulting in the formation of amorphous phase ice, cubic phase ice and hexagonal phase ice by spraying the droplets on a solid cryogenic surface;

(d) continuously removing the rapidly cooled cryosolution from said solid cryogenic surface after said ice has been formed to replenish said surface for cooling of additional droplets; and

(e) drying said rapidly cooled cryosolution to remove said amorphous phase ice, cubic phase ice and hexagonal ice to form a dried cryosolution, said drying being completed to a final residual moisture content of less than about 5%.

25. The method of claim 24 further comprising the step of sealing said dried cryosolution in a container without increasing the residual water content of said dried cryosolution above about 5%.

26. The method of claim 25 wherein said sealing is performed in a dry inert gas atmosphere at a low pressure of from about 10^{-6} mbar to 10^{-1} mbar.

- 50 -

27. The method of claim 24 further comprising rehydrating the dried cryosolution.

28. An apparatus for rapid cryofixation of suspensions of microscopic biological materials comprising:

(a) a nebulizer for creating microdroplets of a suspension of a microscopic biological material in a laminar flow of gas, said gas propelling said microdroplets away from the nebulizer, said microdroplets having diameters of about 25 μm to about 250 μm ;

(b) an internally cooled cryogenic surface for cooling the microdroplets at an approximate cooling rate of 50,000° to 100,000° C./sec. said internally cooled cryogenic surface being functionally located in said laminar flow of gas so that said microdroplets contact and are cooled by said internally cooled cryogenic surface;

(c) an internally cooled collector for removing the cooled microdroplets from the cryogenic surface; and

(d) a removable sample holder for receiving the cooled microdroplets.

29. The apparatus of claim 28 wherein the nebulizer comprises a 25 to 60 kHz ultrasonic nebulizer.

30. The apparatus of claim 28 wherein the cryogenic surface comprises a rotating hollow metal cylinder with high thermal conductivity having a mirror finish.

- 51 -

31. The apparatus of claim 28 wherein the collector comprises a blade formed from polyethylene terephthalate to remove the frozen microdroplets from the cryogenic surface.

32. A rapid cryofixation device, comprising:

(a) a hollow nebulizer column having a closed top end and an open bottom end, the top end of said nebulizer column being connected to tubing through which a dry gas under positive pressure is provided so as to generate a flow of dry gas from the top end to the bottom end of said nebulizer column;

(b) a nebulizer having a discharge nozzle, said nebulizer being positioned within said hollow nebulizer column in such a manner so that the discharge nozzle is directed to the open bottom end of the nebulizer column and so as to generate at least one laminar passage way through which a laminar flow of dry gas is generated and wherein said nebulizer is connected to a conduit through which a cryosolution, said cryosolution comprising a microscopic biological suspension, is supplied to the discharge nozzle so as to form a plurality of microdroplets of the cryosolution within the laminar flow of dry gas;

(c) a cryogenic surface comprising a rotatably mounted hollow cylinder having an inner surface and an outer surface and a high thermal conductivity, the outer surface of said cylinder having a mirror finish and the inner surface of said cylinder being cooled by a liquid cryogen introduced into said cylinder by suitable connecting means, said cryogenic surface being positioned at the open bottom end of said nebulizer column so that the plurality of microdroplets within the laminar flow of dry gas encounter the cryogenic surface and are rapidly cooled to form a plurality of frozen microdroplets on said cryogenic surface;

- 52 -

(d) means for rotating the hollow cylinder of the cryogenic surface;

(e) a collector comprising a blade having an edge and means for holding the edge of said blade in a position so as to remove the plurality of frozen microdroplets from said cryogenic surface to form a frozen sample of said cryogenic solution; and

(f) a removable sample vial holder, said holder having a plurality of openings in which sample vials are held, at least one of said openings being located so as to place the sample vial held therein in a position for collecting the frozen sample.

33. A rapid cryofixation device as recited in claim 32, wherein said nebulizer is operated at a frequency between 25 and 60 kHz so as to form microdroplets having an approximate diameter from about 25 μm to about 250 μm .

34. A rapid cryofixation device as recited in claim 33, wherein the means for rotating the hollow cylinder of the cryogenic surface comprises a drive motor and a gear mechanism.

35. A rapid cryofixation device as recited in claim 33 wherein the hollow cylinder of the cryogenic surface is made of copper, aluminum and chromium or diamond coated aluminum.

36. A rapid cryofixation device as recited in claim 35 wherein the blade of the collector is formed from polyethylene terephthalate.

- 53 -

37. A rapid cryofixation device as recited in claim 32 wherein the removable sample vial holder is a cylinder having a top face and a central axis, said top face having a plurality of openings coaxial to the central axis for holding sample vials, and means for rotating the cylinder of the holder about said central axis so that each coaxial opening containing a vial can be positioned to receive the frozen sample.

38. A rapid cryofixation device as recited in claim 32 wherein the cryofixation solution comprises a cryoprotectant selected from the group consisting of dimethyl sulfoxide, dextran, sucrose, 1,2-propanediol, glycerol, sorbitol, fructose, trehalose, raffinose, hydroxyethyl starch, propylene glycol, 2,3-butane diol, polyvinylpyrrolidone, proline, human serum albumin and combinations thereof.

39. A rapid cryofixation device, comprising:

(a) a hollow nebulizer column having a closed top end and a open bottom end, the top end of said nebulizer column being connected to tubing through which a dry gas under positive pressure is provided so as to generate a flow of dry gas from the top end to the bottom end of said nebulizer column;

(b) an ultrasonic nebulizer having a discharge nozzle, said nebulizer being positioned within said hollow nebulizer column in such a manner so that the discharge nozzle is directed to the open bottom end of the nebulizer column and so as to generate at least one passage way through which a laminar flow of dry gas is generated and wherein said nebulizer is operated at a frequency between 25 and 60 kHz and is connected to a conduit through which a cryosolution, said cryosolution comprising a microscopic biological suspension, is supplied to the discharge nozzle so as to form a plurality of microdroplets of the cryosolution within

- 54 -

the laminar flow of dry gas;

(c) a cryogenic surface, said cryogenic surface being positioned at the open bottom end of said nebulizer column so that the plurality of microdroplets within the laminar flow of dry gas encounter the cryogenic surface and are rapidly cooled to form a plurality of frozen microdroplets on said cryogenic surface;

(d) a collector comprising a blade having an edge and means for holding the edge of said blade in a position so as to remove the plurality of frozen microdroplets from said cryogenic surface to form a frozen sample of said cryogenic solution; and

(e) means for collecting said frozen sample of said cryogenic solution.

40. A cryoprotective solution selected from the group consisting of:

(1) a mixture of 0.5 molar dimethyl sulfoxide, 0.5 molar propylene glycol, 0.25 molar 2,3 butanediol, 1.0 molar proline, 2.5% raffinose and 15% polyvinylpyrrolidone;

(2) a mixture of 0.5 molar dimethyl sulfoxide, 0.5 molar propylene glycol, 0.25 molar 2,3 butanediol, 10% raffinose, 6% trehalose, 6% sucrose, 12% polyvinylpyrrolidone and 12% dextran; and

(3) a mixture of 0.5 molar dimethyl sulfoxide, 0.5 molar propylene glycol, 0.25 molar 2,3 butanediol, 2.5% raffinose, 12% sucrose, 15% polyvinylpyrrolidone and 12% dextran.

FIG.1

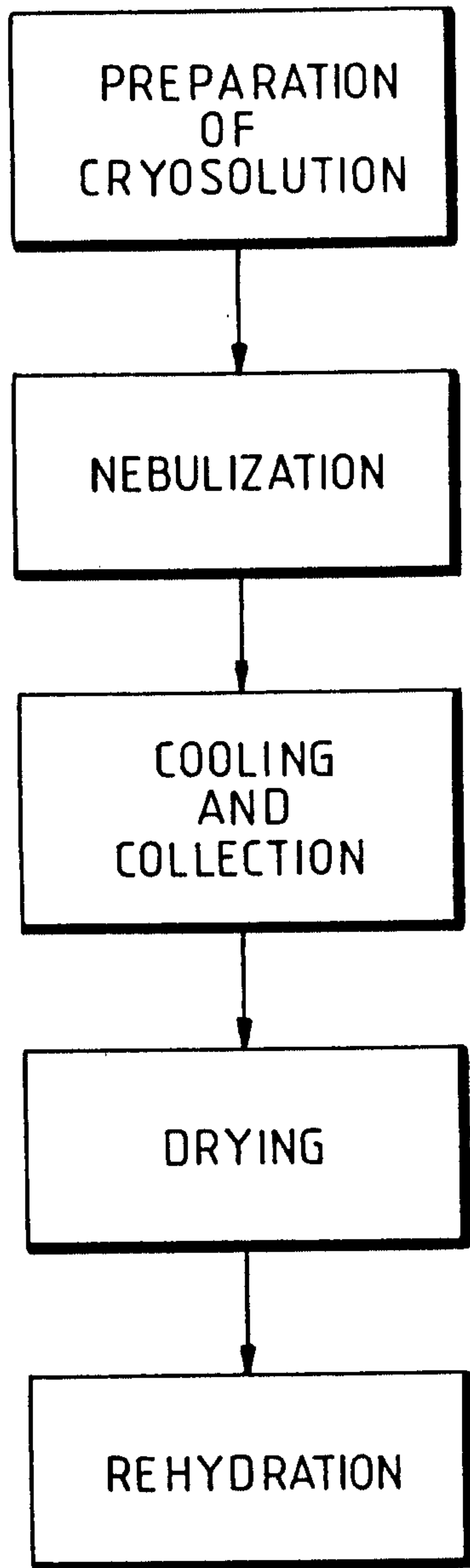

Sulayman Al-Singh
PATENT AGENTS

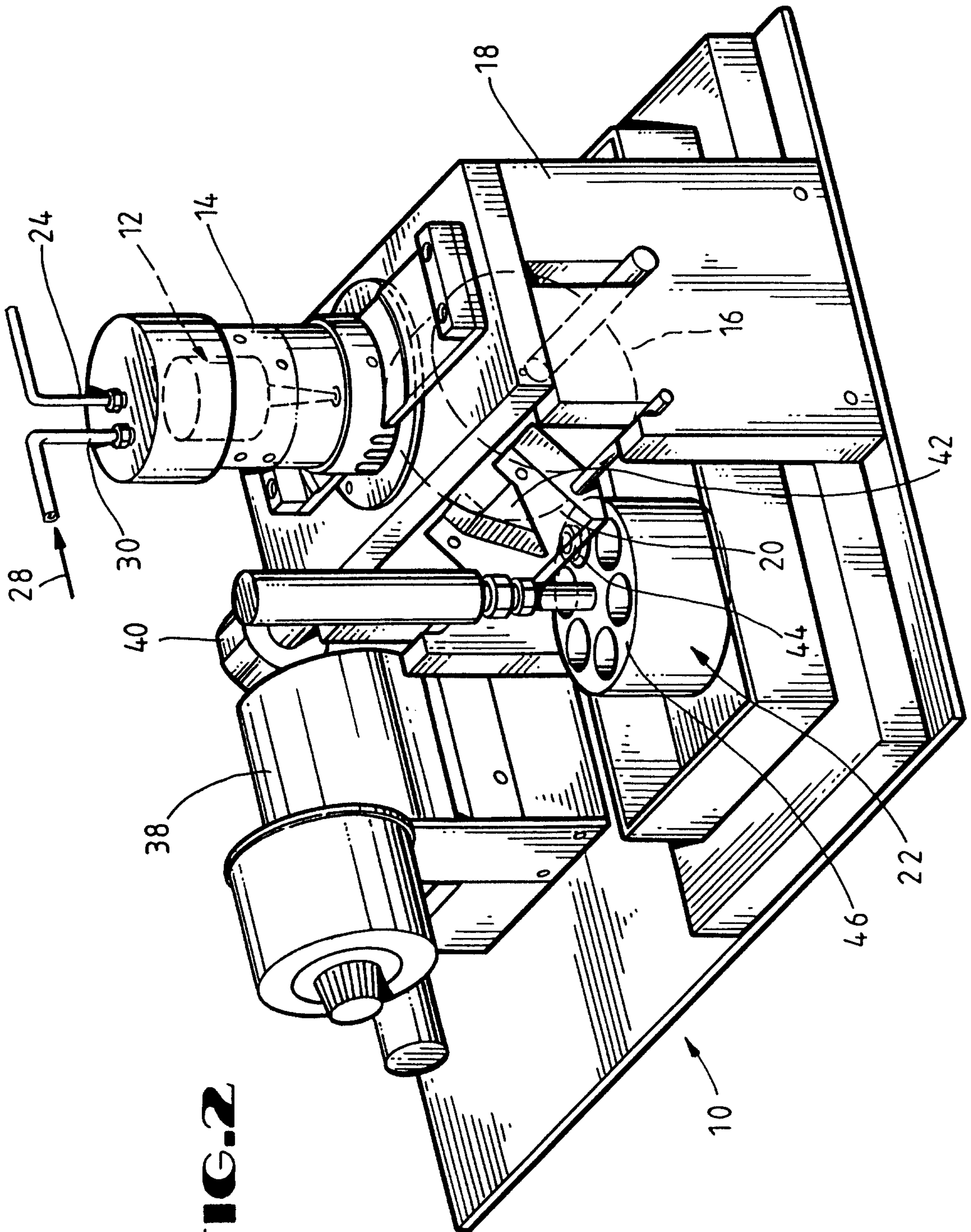
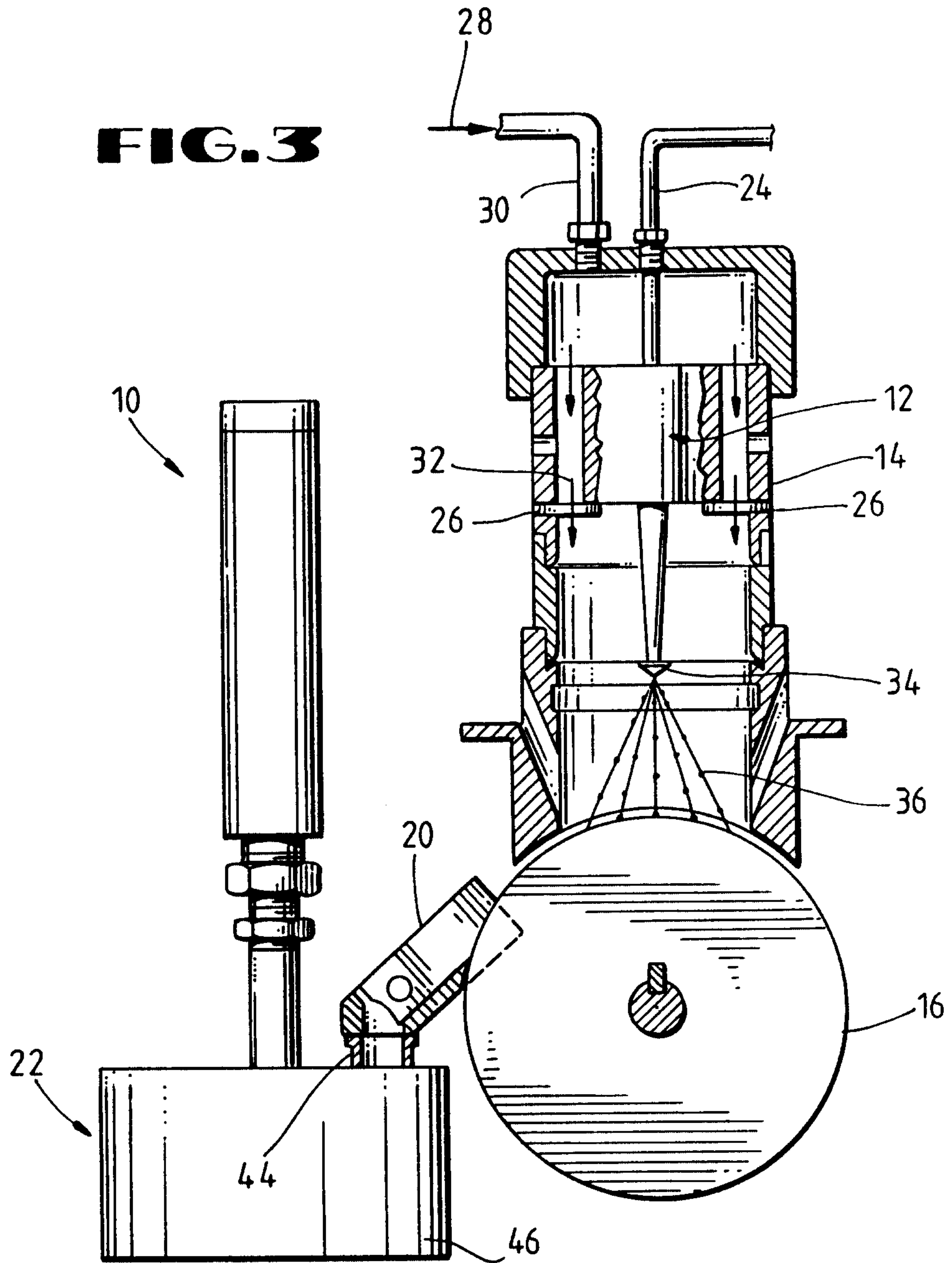

FIG. 2

Inlay & Associates
PATENT AGENTS

FIG. 3



Julay & Singlet
PATENT AGENTS

