

J. B. WOODRUFF.
Sewing Machine.

No. 13,242.

Patented July 10, 1855.

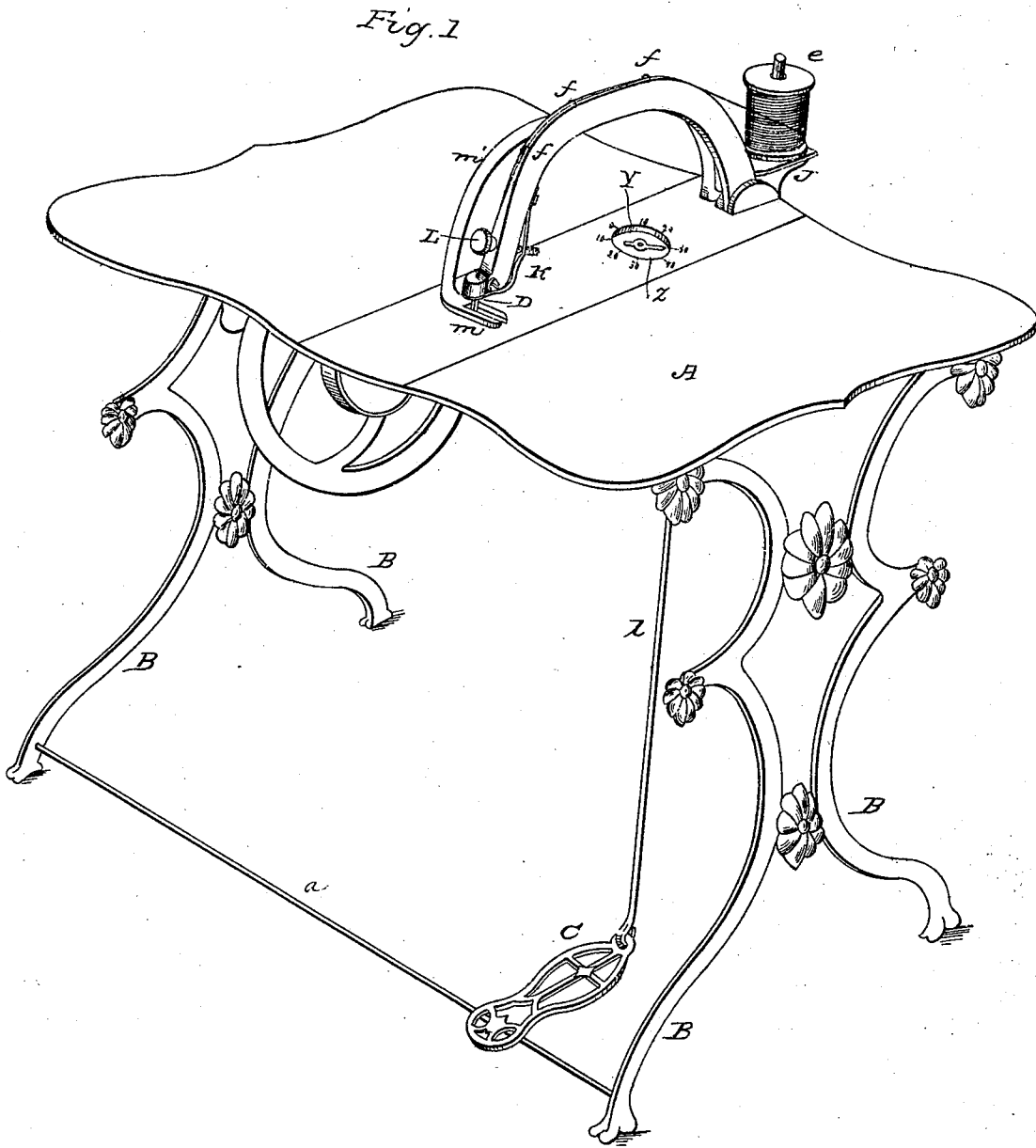

J. B. WOODRUFF.
Sewing Machine.

4 Sheets—Sheet 2.

No. 13,242.

Patented July 10, 1855.

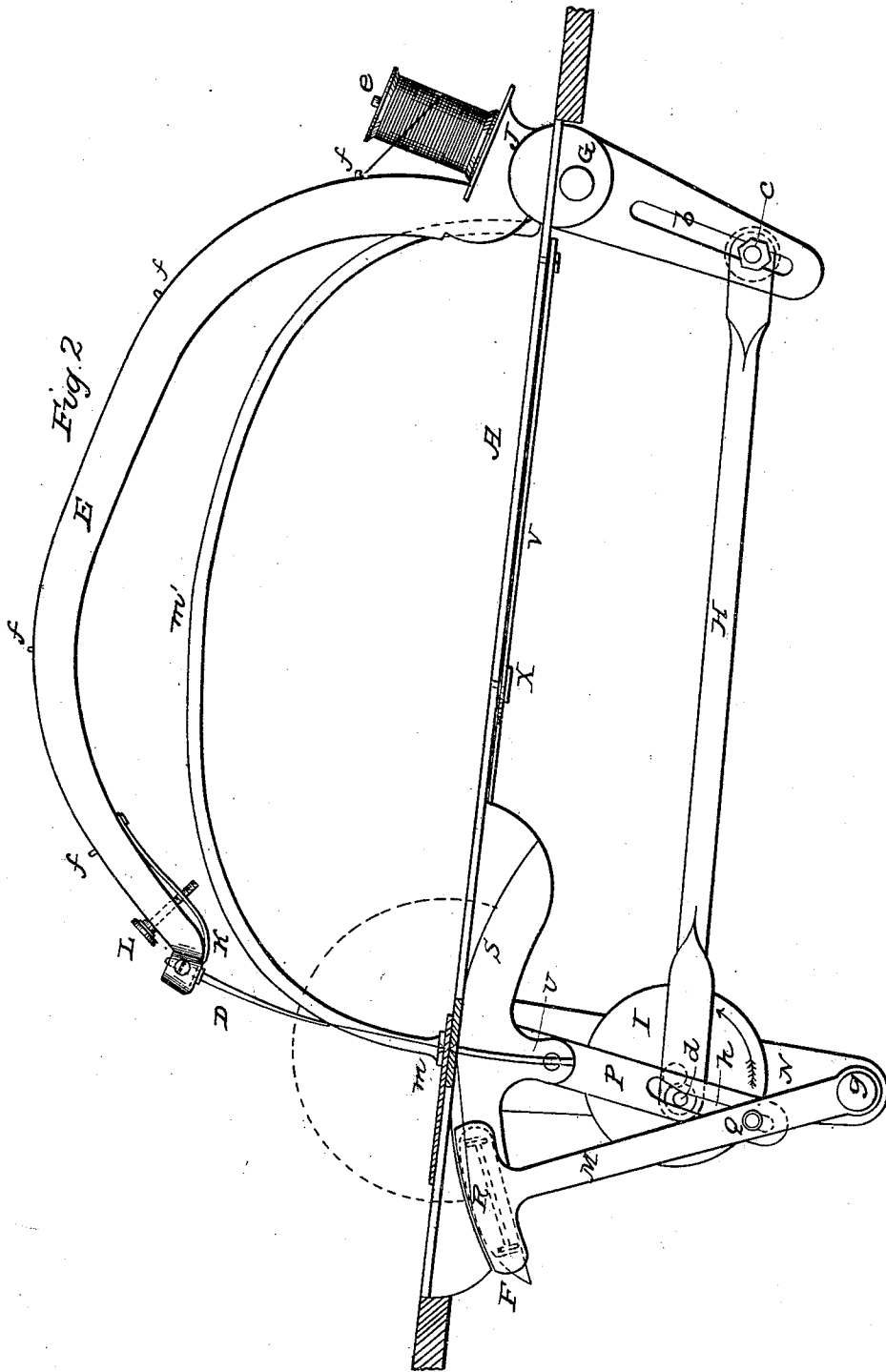

J. B. WOODRUFF.
Sewing Machine.

No. 13,242.

Patented July 10, 1855.

Fig. 3

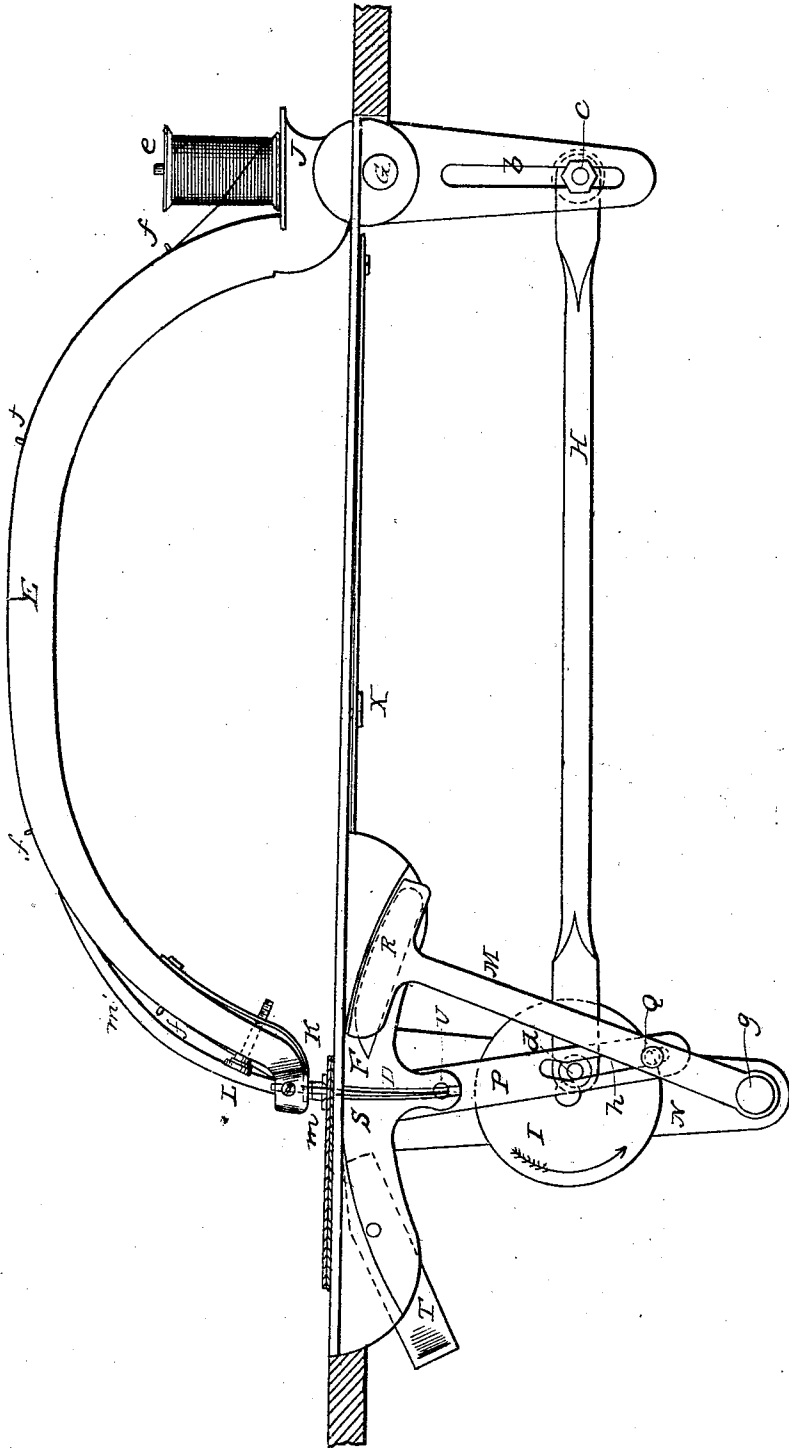

J. B. WOODRUFF.
Sewing Machine.

No. 13,242.

Patented July 10, 1855.

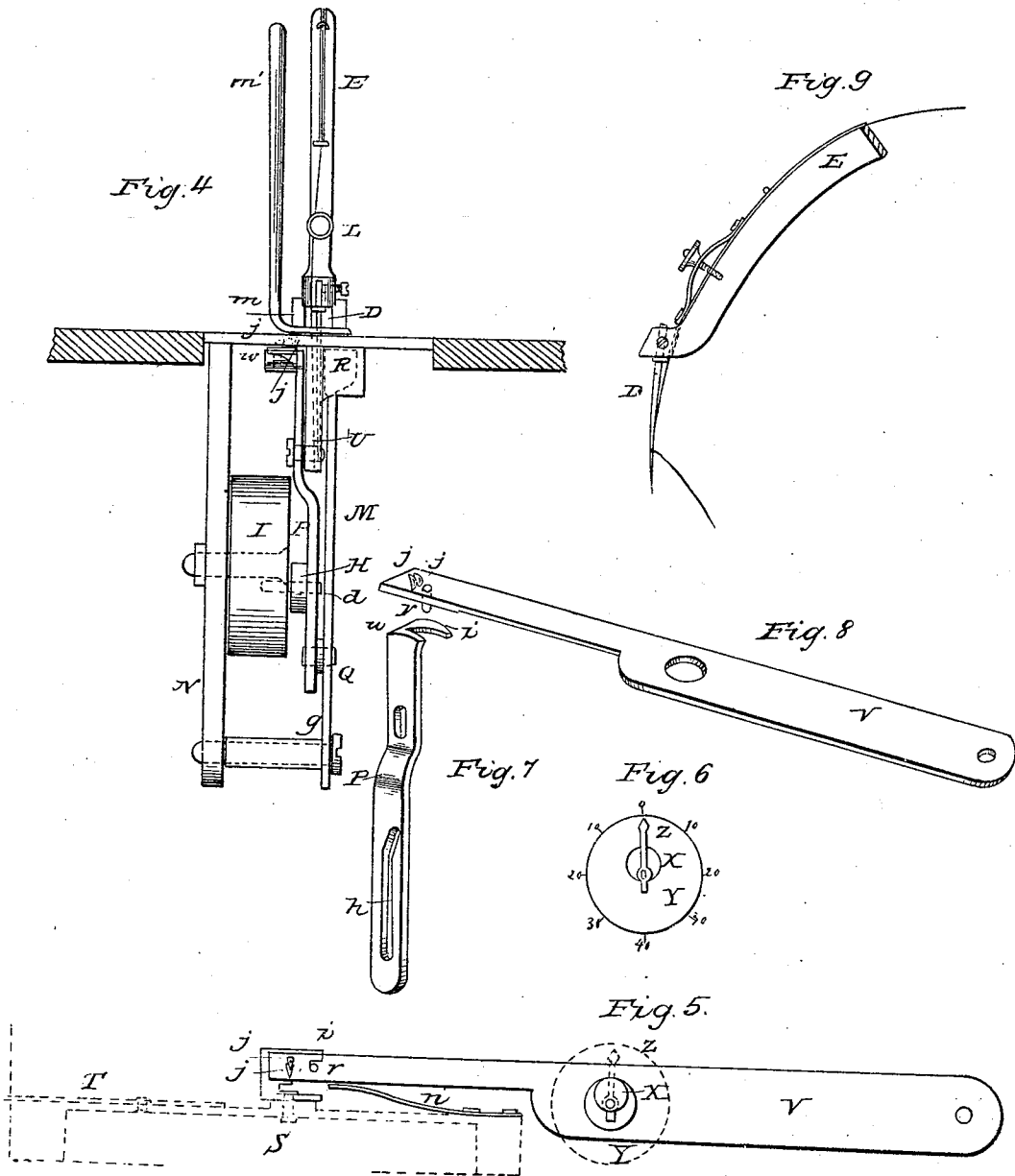

UNITED STATES PATENT OFFICE.

JEROME B. WOODRUFF, OF WASHINGTON, DISTRICT OF COLUMBIA.

IMPROVEMENT IN SEWING-MACHINES.

Specification forming part of Letters Patent No. 13,242, dated July 10, 1855.

To all whom it may concern:

Be it known that I, JEROME B. WOODRUFF, of the city of Washington, in the District of Columbia, have invented certain new and useful Improvements in Sewing-Machines, of which the following is a full, clear, and exact description, reference being had to the accompanying drawings, in which—

Figure 1 represents a view in perspective of a machine embracing my improvements. Fig. 2 represents an elevation of the same, omitting the lower part of the frame and showing a portion of the upper part in section, the needle in this view being raised and the shuttle thrown forward to show the manner in which the threads are drawn to tighten the stitch. Fig. 3 represents a similar view with the needle depressed to carry one thread through the cloth, and the shuttle which carries the other thread drawn back ready to be carried forward through the loop formed by the upward movement of the needle. The last two views also represent the mechanism for operating the shuttle and needle. Fig. 4 represents an elevation of the front end of the machine and a section of a portion of the upper part of the table. This view shows more fully the construction and arrangement of the feeding mechanism. Figs. 5, 6, 7, and 8 represent views of the several parts of the feeding mechanism detached from the machine and separated. Fig. 9 represents a view of a modified arrangement of the spring for tightening the needle-thread shown on a fragment of the needle-arm.

My invention and improvement relates to the construction, arrangement, and operation of the mechanism for operating the shuttle and needle, to the shuttle-race, to the feeding mechanism, and the method of graduating the length of the stitch and indicating the same.

This machine is of the variety in which the stitch is made by the interlacing of two threads, one of which is carried by a shuttle and the other by a needle.

The machine as represented in the drawings consists of a strong table, A, supported on suitable legs, B.

On a rod, *a*, connecting the front legs of the table, a treadle, C, is arranged, through which motion is communicated to the machine by the foot of the attendant in the usual manner.

The needle D is carried on the front extremity of a vibrating arm, E, and the shuttle

F is carried on the upper extremity of another vibrating arm, M. The needle-arm E is of the irregular curved form represented in Figs. 1, 2, and 3, and turns on a pivot, G, near the end opposite to that at which the needle is carried. The extremity of the arm, near the pivot I shall, for convenience, call the "lower end" and that on which the needle is affixed the "upper end." The lower end of this arm is pierced with a slot, *b*, to which an adjustable wrist-pin, *c*, is fitted. This wrist-pin is connected by a link-rod, H, to another wrist-pin, *d*, on a revolving pulley, I, which pulley as it turns communicates through the link-rod H a vibratory motion to the lower end of the needle-arm, whose upper end will move through a longer or shorter arc as the wrist-pin *c* is adjusted in its slot *b* at a greater or less distance from the pivot *d*. By this means the motion of the needle-arm can be adapted to the length of the needle or the amount of vibration necessary to form a loop of the proper size for the passage of the shuttle through it.

Immediately above the pivot *c* the needle-arm has an offset, J, formed on it, from the center of which a stem, *e*, projects to support the spool which supplies the thread to the needle. The thread passes from the spool through guide-loops *f* on the upper side of the needle-arm, to the upper extremity of the same, where it passes through an aperture by the side of the needle. At the point where the thread emerges from the lower end of this aperture an adjustable spring rubber or bar, *k*, is arranged to press the thread against the side of the aperture to produce such a degree of friction that the force required to draw it off the spool will be sufficient to draw the stitch to the proper degree of tightness. This spring-rubber *k* is adjusted by the thumb-screw L. By this arrangement the thread is clamped by the brake close to the needle, instead of being clamped at or near the opposite end of the arm, as heretofore. This contrivance holds the thread firmly, and it is drawn by the needle as evenly and regularly as the shuttle draws its thread. This could not be done when the thread was clamped so far from the stitch, because of the extremely variable elasticity of so long a thread. At the time when the needle is raised to the highest point and the shuttle thrown to its extreme forward position the distance between the aperture at which the thread leaves the side of

the shuttle and the stitch is the same as the distance between the eye of the needle and the stitch. This insures an equal tension upon both the needle and shuttle threads, which more fully insures the interlooping of the threads in the body of the cloth being sewed.

The arm M, which carries the shuttle, turns on a pivot, *g*, affixed to a bracket, N, which projects down from the underside of the table. This shuttle-arm derives its motion from a slot, *h*, in the lower end of a vibrating feeding-arm, P, through the medium of a driving-pin, Q, which projects laterally from the shuttle-arm. The upper end of the shuttle-arm carries a shuttle-box, R, of the proper size and form to receive the shuttle and drive it. This shuttle-box R and its arm M resemble in their general configuration a ladle having an oblong bowl placed with the long axis at right angles to the shank, the side of the bowl opposite the shank being cut off, and one end of the bowl notched to admit the shuttle and permit it to be withdrawn more readily, the opposite end of the bowl being left entire to operate as a driver to the shuttle. The shuttle-box R vibrates in a curved race, S, which closes the upper side and back of the box to keep the shuttle in.

At the front end of the race a guard or gate, T, is arranged, which is opened or shut, as required, for putting in, confining in place, or withdrawing the shuttle.

The feeding-arm P is pivoted to the bracket U, projecting from the lower edge of the race, and the same wrist-pin, *d*, that operates the connecting-rod H also operates the feeding-arm by extending into the slot *h* in said arm, as shown in Fig. 4. By this arrangement the wrist-pin *d* is made to perform several duties. It may be made to operate the shuttle-arm likewise by properly proportioning the parts and making a slot of the proper form in the shuttle-arm, into which the pin would extend to operate this arm in the same manner that it operates the feeding-arm.

The upper end of the feeding-arm carries an inclined plane, *i*, which performs the feeding by striking against a pin on the under side of a feeding-pawl, and deflecting the same a distance equal to the length of the stitch required. The upper end of the feeding-arm likewise carries the teeth of the feeding-pawl alternately into and permits them to be withdrawn from contact with the cloth.

The feeding-pawl consists of a long flexible spring-bar, V, pivoted at its rear end to the under side of the table, and on its front end carries teeth *j*. A spring, *n*, constantly tends to push the pin *r* of the pawl into contact with the inclined plane *i*. An adjustable eccentric pin, X, is arranged to act against the pawl to move it laterally (more or less) to set it in such position that the inclined plane *i* will strike it sooner or later, as it is required to feed more or less to produce a longer or shorter stitch.

The relative lengths of the different stitches,

produced by setting the pawl in various positions by means of the eccentric pin X, are indicated by the dial-plate Y and pointer Z, so that if a given length of stitch or number of stitches to the inch is required the operator can instantly adjust the machine to produce it by moving the pointer over the dial-plate until it is opposite the number required. The inclined plane *i* is vibrated by the arm P once for each vibration of the needle and shuttle, so that the feeding and sewing will proceed regularly and in due proportion to each other.

As it is necessary that the feeding should take place after the needle is withdrawn from the cloth and before it re-enters, the form of the slot *h* in the feeding-arm at the point where the pin *d* works in it is curved in such manner that during the time the needle is in the cloth the feeding-pawl shall either remain still or not affect the feeding.

The elevation of the teeth of the pawl is caused by the raising of the upper extremity, *w*, of the feeding-arm P as it moves in its arc of vibration. As the end of the arm is thus raised, the pawl, the front end of which rests upon it, is correspondingly elevated to engage the teeth with the cloth. The depression of the pawl-teeth is caused by the descent of the end of the pawl, either by its weight or by a tendency to spring downward as the end of the arm descends the arc of its retrograde motion.

The pulley I, which carries the wrist-pin *d*, is the second driving-pulley of the machine, and derives motion from a corresponding pulley (through the medium of a belt) on the crank-shaft, whose motion is communicated from the treadle through the link *l*. The cloth is held upon the table by a slotted clamp, *m*, on the front extremity of a bow-spring, *m'*, whose rear extremity is secured to the table.

Having thus described my improved sewing-machine, what I claim therein as my invention, and desire to secure by Letters Patent, is—

1. The arrangement of the needle, shuttle, and feeding-arms, the connecting-rod H, and pulley P, with its wrist-pin *d*, substantially in the manner and for the purpose herein set forth.

2. The giving to the needle and the shuttle such relative range of vibration that at the time the shuttle is forward, the needle raised, and the tension upon the stitch the greatest, the distance between the eye of the needle and the eye of the shuttle and the stitch will be equal, thereby more effectually insuring an equal draft on both threads of the stitch within the body of the cloth.

3. The combination of the feeding-pawl with the feeding-lever to raise and lower the teeth of the pawl, and the inclined plane to vibrate them laterally, in the manner and for the purpose herein set forth.

4. The combination, with the feeding-pawl of the eccentric pin X, a pointer, Z, and an in-

dex or dial graduated and numbered, whereby the machine can be adjusted to vary the length of the stitches at will to any required number to the inch, and the number which the machine as adjusted will make can at any time be observed without measurement or calculation, whether it be in operation or not.

In testimony whereof I have hereunto subscribed my name.

JEROME B. WOODRUFF.

Witnesses:

F. G. FONTAINE,
A. E. H. JOHNSON.