

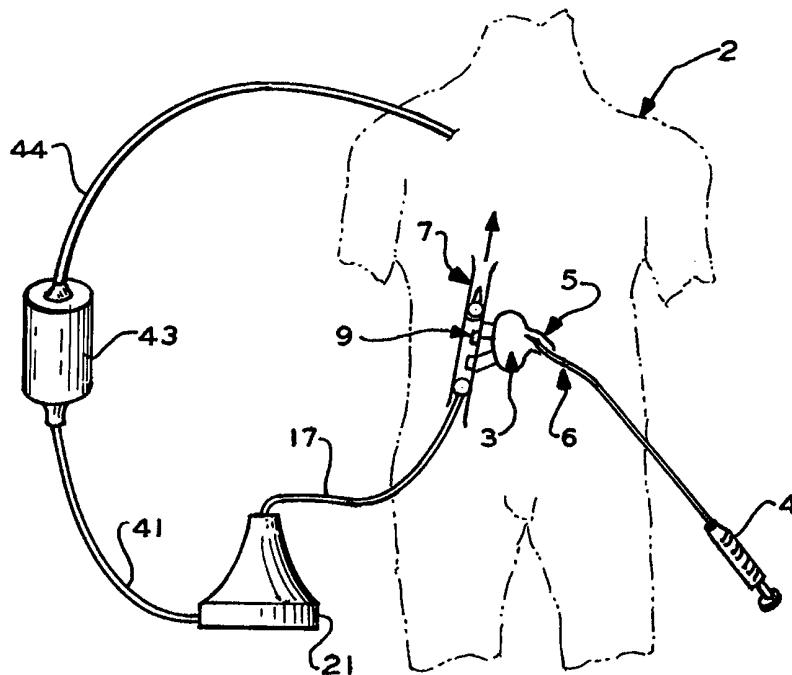

INTERNATIONAL APPLICATION PUBLISHED UNDER THE PATENT COOPERATION TREATY (PCT)

<p>(51) International Patent Classification ⁶ : A61M</p>	<p>A2</p>	<p>(11) International Publication Number: WO 99/02202 (43) International Publication Date: 21 January 1999 (21.01.99)</p>
<p>(21) International Application Number: PCT/US98/14717 (22) International Filing Date: 14 July 1998 (14.07.98) (30) Priority Data: 08/891,744 14 July 1997 (14.07.97) US (71) Applicant: DELCATH SYSTEMS, INC. [US/US]; 1100 Summer Street, Stamford, CT 06905 (US). (71)(72) Applicant and Inventor: GLICKMAN, Morton, G. [US/US]; Yale University School of Medicine, 333 Cedar Street, New Haven, CT 06520 (US). (74) Agent: FELDMAN, Stephen, E.; Stephen E. Feldman, P.C., 12 East 41st Street, New York, NY 10017 (US).</p>		<p>(81) Designated States: AL, AM, AT, AU, AZ, BA, BB, BG, BR, BY, CA, CH, CN, CU, CZ, DE, DK, EE, ES, FI, GB, GE, GH, GM, HU, ID, IL, IS, JP, KE, KG, KP, KR, KZ, LC, LK, LR, LS, LT, LU, LV, MD, MG, MK, MN, MW, MX, NO, NZ, PL, PT, RO, RU, SD, SE, SG, SI, SK, SL, TJ, TM, TR, TT, UA, UG, UZ, VN, YU, ZW, ARIPO patent (GH, GM, KE, LS, MW, SD, SZ, UG, ZW), Eurasian patent (AM, AZ, BY, KG, KZ, MD, RU, TJ, TM), European patent (AT, BE, CH, CY, DE, DK, ES, FI, FR, GB, GR, IE, IT, LU, MC, NL, PT, SE), OAPI patent (BF, BJ, CF, CG, CI, CM, GA, GN, GW, ML, MR, NE, SN, TD, TG).</p> <p>Published <i>Without international search report and to be republished upon receipt of that report.</i></p>

(54) Title: CATHETER WITH SLIDABLE BALLOON



(57) Abstract

The instant invention provides a novel double balloon catheter which includes a first fixed balloon on the cranial end of the catheter; a second slidable balloon positioned around the catheter and spaced from the first fixed balloon; and, structure for enabling the second balloon to slide along the plastic tube between a first position defining a minimum distance between the first balloon and the second balloon, and a second position defining a maximum distance between the first balloon and the second balloon. The invention also contemplates a novel method of using the catheter.

FOR THE PURPOSES OF INFORMATION ONLY

Codes used to identify States party to the PCT on the front pages of pamphlets publishing international applications under the PCT.

AL	Albania	ES	Spain	LS	Lesotho	SI	Slovenia
AM	Armenia	FI	Finland	LT	Lithuania	SK	Slovakia
AT	Austria	FR	France	LU	Luxembourg	SN	Senegal
AU	Australia	GA	Gabon	LV	Latvia	SZ	Swaziland
AZ	Azerbaijan	GB	United Kingdom	MC	Monaco	TD	Chad
BA	Bosnia and Herzegovina	GE	Georgia	MD	Republic of Moldova	TG	Togo
BB	Barbados	GH	Ghana	MG	Madagascar	TJ	Tajikistan
BE	Belgium	GN	Guinea	MK	The former Yugoslav Republic of Macedonia	TM	Turkmenistan
BF	Burkina Faso	GR	Greece	ML	Mali	TR	Turkey
BG	Bulgaria	HU	Hungary	MN	Mongolia	TT	Trinidad and Tobago
BJ	Benin	IE	Ireland	MR	Mauritania	UA	Ukraine
BR	Brazil	IL	Israel	MW	Malawi	UG	Uganda
BY	Belarus	IS	Iceland	MX	Mexico	US	United States of America
CA	Canada	IT	Italy	NE	Niger	UZ	Uzbekistan
CF	Central African Republic	JP	Japan	NL	Netherlands	VN	Viet Nam
CG	Congo	KE	Kenya	NO	Norway	YU	Yugoslavia
CH	Switzerland	KG	Kyrgyzstan	NZ	New Zealand	ZW	Zimbabwe
CI	Côte d'Ivoire	KP	Democratic People's Republic of Korea	PL	Poland		
CM	Cameroon	KR	Republic of Korea	PT	Portugal		
CN	China	KZ	Kazakstan	RO	Romania		
CU	Cuba	LC	Saint Lucia	RU	Russian Federation		
CZ	Czech Republic	LI	Liechtenstein	SD	Sudan		
DE	Germany	LK	Sri Lanka	SE	Sweden		
DK	Denmark	LR	Liberia	SG	Singapore		
EE	Estonia						

TITLE

CATHETER WITH SLIDABLE BALLOON

5

BACKGROUND OF THE INVENTION

The instant invention provides a novel apparatus and process of perfusing a high concentration of a chemotherapeutic agent through a tumor occurring in an isolated portion of a patient, without contaminating the blood circulating in the substantial remainder of the patient's blood circulatory system outside of the isolated portion, with the agent. The invention enables the by-pass of the contaminated blood through an extracorporeal circuit which includes a scheme for decontaminating the contaminated blood. After decontamination, the blood is thereafter infused back into the body of the patient at a point remote from where it was initially withdrawn. Thus, the invention prevents otherwise toxic levels of such agents from entering the substantial remainder of the patient's blood circulatory system; while at the same time, delivering doses of the agent which are substantially lethal only to the tumor located within the isolated portion. The key to isolating a portion of the patient's body from the substantial remainder of the patient's blood circulating system, is a double balloon catheter. The instant invention purports an improvement to the prior art by providing at least one novel slidable balloon on a double balloon catheter.

Perfusion of chemotherapeutic agents through an isolated portion of a patient's body is well known in the prior art. Removal of blood contaminated with chemotherapeutic agents from the thusly isolated portion through a double balloon catheter is also well known in the prior art, as exemplified by the following United States Patents.

30

United States Patent 5,411,479 to Bodden, teaches perfusion of a high concentration of an agent to treat an organ, such as anti-cancer agents through a body organ containing a tumor, without their entering the body's general circulation, removing them from the organ with effluent blood and transporting the

contaminated blood to an extracorporeal circuit where the blood is treated to remove the contamination, and returning the treated blood to the body. The process prevents toxic levels of the agents from entering the body's general circulation while delivering lethal doses of the agents to the tumor. There are described various apparatus for effecting the intra- and extracorporeal treatment of such contaminated blood.

United States Patent 5,069,662 to Bodden, teaches the perfusion of a high concentration of an agent to treat an organ, such as anti-cancer agents through a body organ containing a tumor, without their entering the body's general circulation, removing them from the organ with effluent blood and transporting the contaminated blood to an extracorporeal circuit where the blood is treated to remove the contamination, and returning the treated blood to the body. The process prevents toxic levels of the agents from entering the body's general circulation while delivering lethal doses of the agents to the tumor. There are described various apparatus for effecting the intra- and extracorporeal treatment of such contaminated blood.

United States Patent 5,597,377, to Aldea teaches a catheter for retroperfusion of myocardium has an infusion tip, such that when retroperfusing myocardium, the tip extends within the coronary sinus to a depth in a range of about 2 to 4 inches (5 to 10 cm) from the coronary sinus ostium. The catheter also comprises a tube defining at least three channels. The channels include an infusion channel, which has a first infusion end coupled to an infusion port located in the infusion tip and a second infusion end coupled to an outlet orifice of a pump; a withdrawal channel, which has a first withdrawal end coupled to a withdrawal port located in the superior vena cava and a second withdrawal end coupled to an inlet orifice of the pump; and a pressure monitoring channel for monitoring pressure at pressure port at the infusion tip having a first monitoring end coupled to the pressure port and a second monitoring end coupled to a pressure sensor. The catheter also has a microprocessor for controlling the pump and measuring a rate

of retroperfusate flow, whereby autologous venous blood entering the withdrawal port is continuously discharged at the infusion port at a flow rate in a range of about 5 to 50 mil./min. and at a pressure less than about 15 mm Hg. The tube and tip are made from biocompatible, non-thrombogenic material. Further, the catheter has remotely identifiable markers spaced along the tube, and a marker is located at said infusion tip. The invention also is a method for coronary sinus retroperfusion. The method includes the steps of inserting the catheter through the patient's jugular vein; guiding the catheter's infusion tip into the coronary sinus, such that when retroperfusing myocardium, the tip extends within the coronary sinus to a depth in a range of about 2 to 4 inches (5 to 10 cm) from the coronary sinus ostium; and providing a non-synchronized retroperfusate flow of autologous venous blood at a rate in a range of about 5 to 50 mil./min. and at a pressure less than about 15 mm Hg.

United States Patent 5,569,182 Twardowski, et. al., teaches blood which is circulated through a multiple lumen catheter which connects between a vein of a patient and the blood treatment device. The catheter and the lumens thereof each define distal ends which are positioned within the vein. By this invention, one withdraws blood from the vein through one of the lumens at a flow rate of at least about 200 ml./min. while also inserting blood into the vein through another of said lumens at a similar flow rate. The distal ends of the lumens are longitudinally spaced from each other by no more than about 5 mm. It have been found that the following advantages can be achieved by this method: less clot formation coupled with low direct blood recirculation and longer catheter survival. Also, the catheter works well in either direction of blood flow through the respective lumens.

United States Patent 5,509,897, to Twardowski, et. al., teaches a catheter for hemodialysis comprises a flexible catheter tube defining a plurality of separate lumens. The catheter defines an arc angle of generally U-shape in its natural, unstressed configuration. Thus, the catheter may be implanted with a distal catheter portion residing in a vein of the patient, the distal catheter portion being

of substantially the shape of the vein in its natural, unstressed condition. Also, a proximal catheter portion resides in a surgically created tunnel extending from the vein and through the skin of the patient, this section of the Catheter also being typically in its natural, unstressed condition. Thus, blood may be removed from the vein through one lumen of the catheter, and blood may be returned to the vein through another lumen of the catheter, while the catheter is subject to long term indwelling in the body. Improved results are achieved because of the lack of mechanical stress in the shape of the catheter, which stress causes the catheter to press unduly against adjacent tissues.

10

United States Patent 5,505,698, to Booth, et. al., teaches a catheter for supplying liquid to the coronary sinus in a perfusion procedure comprising a tubular catheter body having an interior lumen, a proximal end, and a distal end; and an inflatable cuff (balloon) adjacent the distal end of the catheter. The cuff has a proximal end and a distal end, each of which encircle the catheter body and hermetically seal thereto. The cuff further comprises an elongated central section having a length of at least 1 inch. When the inflated cuff is positioned a sufficient distance into the coronary sinus to firmly retain the cuff therein, it blocks the left coronary vein where it meets the coronary sinus. Further, the cuff can comprise end panels defined between the central section and the proximal and distal cuff ends. The end panels have a shape which allows for flexure between the central section and the cuffs proximal and distal ends.

15

20

25

30

United States Patent 5,489,274, to Chu, et. al., teaches an easy operating, durable closure device for controlling the closure of a passageway in for example valves and the like used in medical applications. The device includes a cam surface arranged about the circumference of a resilient tubing member. Rotation of the cam controls the radial position of a compression member that compresses the tubing member to effect closure. Such a closure device, or a two-part rotary closure device in general, is constructed to receive an accessory component such as a syringe, the rotary connecting movement of which automatically opens the closure device. The

device may be used as a torqueable handle for a guidewire gripped in the passage. A large scale version of the device is joined to an introducer sheath, sized to pass an introducer catheter for e.g., a Green field filter, or to close upon a guidewire to prevent backflow of blood.

5

United States Patent 5,462,529, to Simpson, et. al., teaches a catheter device for treatment of disease in biological conduits. The device has inner and outer coaxial catheter members, each having an inflatable balloon attached near its distal end. When the balloons are inflated, a sealed treatment chamber is created
10 between the balloons. The length of the treatment chamber is adjustable by sliding the coaxial catheter members with respect to each other to obtain a desired separation between the attached balloons before inflation. Biological debris is trapped within the chamber and removed by infusion and aspiration of a flushing fluid, reducing the risk of myocardial infarction. Adjunctive treatment devices can
15 be inserted into the sealed treatment chamber through a lumen of the outer coaxial member.

United States Patent 5,458,583, to McNeely, et. al. A system and method for inserting a gastrostomy catheter through a passageway formed through the
20 abdominal and stomach walls of a patient. The gastrostomy catheter is mounted onto a dilatation catheter with a dilatation member such as an inelastic balloon on the distal extremity thereof. An introducer needle is first advanced through the walls of the patient's abdomen and stomach into the interior of the stomach and then a guidewire is advanced through the inner lumen of the needle into the
25 stomach interior. The gastrostomy catheter-dilatation catheter assembly is advanced over the guidewire until the balloon on the dilatation catheter is in proper position crossing both the abdominal and gastric walls. Upon inflation of the balloon on the dilatation catheter, the passageway is expanded enough so that the gastrostomy catheter can be advanced therethrough to dispose the distal end of the
30 gastrostomy catheter within the interior of the stomach. The balloon on the distal end of the gastrostomy catheter is inflated so as to form an internal retention

member and the catheter withdrawn in order to urge the inflated balloon against the stomach wall. Preferably, the gastrostomy catheter has an external retention ring on the shaft thereof which is slid against the exterior of the patient's abdomen to seal the passageway through the abdominal wall.

5

United States Patent 5,423,745 to Todd, et. al., teaches balloon catheters for use in infusing a solution into a body passageway, and their methods of use and manufacture. Each catheter contains at least one lumen through which a solution flows into the body. The balloons of each catheter are secured to the proximal end
10 of the catheter, and each have a plurality of protuberances projecting outwardly from the outer surface of the balloons for the purpose of firmly gripping the walls of the body passageway so as to secure placement of the catheter within the passageway. A malleable wire assists in retaining the catheter in position within the body passageway. A double balloon catheter allows sealing of the body
15 passageway to be accomplished separately from securely gripping the walls.

United States Patent 5,405,320, to Twardowski, et. al., teaches a catheter for hemodialysis comprises a flexible catheter tube defining a plurality of separate lumens. The catheter defines an arc angle of generally U-shape in its natural,
20 unstressed configuration. Thus, the catheter may be implanted with a distal catheter portion residing in a vein of the patient, the distal catheter portion being of substantially the shape of the vein in its natural, unstressed condition. Also, a proximal catheter portion resides in a surgically created tunnel extending from the vein and through the skin of the patient, this section of the catheter also being
25 typically in its natural, unstressed condition. Thus, blood may be removed from the vein through one lumen of the catheter, and blood may be returned to the vein through another lumen of the catheter, while the catheter is subject to long term indwelling in the body. Improved results are achieved because of the lack of mechanical stress in the shape of the catheter, which stress causes the catheter
30 to press unduly against adjacent tissues.

United States Patent 5,398,687, to Abel, teaches new devices and methods for detecting and diagnosing motility abnormalities within the pancreaticobiliary tree. In the first device, a modified ERCP catheter with electrical activity sensing is positionable within the biliary tract, and operates to sense electrical activity during the ERCP procedure. Electrical activity is sensed by two circumferential leads formed by bands of silver, located near the distal tip of the catheter. The detection of electrical activity, in combination with the simultaneous radioscopic visualization of the biliary tract, provides a detailed motility profile for the physician without requiring the additional use of a perfusion catheter. A second device is also disclosed which detects motility within the biliary tract by the simultaneous sensing of electrical activity and surrounding fluid pressure. A biliary catheter has two circumferential silver leads and three perfusion lumens whose outlets are alternately spaced between the silver leads. When positioned within the biliary tract, this catheter yields valuable data correlating electrical activity and the corresponding occurrence of muscle activity. By the sequential detection of pressure changes at the proximal, medial, and distal perfusion outlets interspersed between the electrical activity leads, both the presence and direction of muscle activity are sensed in relation to the sensed electrical activity about the leads.

United States Patent 5,397,310, to Chu, et. al., a catheter introducer sheath assembly, for introduction into a body passage of a catheter containing a filter comprises a flexible introducer sheath joined to the distal end of a closure device forming a through-passage with a diameter sufficient to pass the catheter therethrough. The closure device has a resilient member in the through-passage and two rotatable body portions, one stationary with respect to the resilient member, and the other rotatable about the axis of the resilient member with an internal cam circumferentially spaced around the axis. A compression member positioned radially in an extending aperture makes contact with both the resilient member and the cam surface to vary the through-passage allowing the operator to manually control the passage of the device. The sheath assembly receives a catheter guidewire that slides through and extends beyond the closure device and

the sheath. In another aspect, the combination sheath assembly and closure device forms a catheter introducer kit constructed to receive a stabilizer and a catheter of sufficiently large diameter to house a vena cava filter, and to pass the filter through the closure device and sheath for placement in the body by means of a dilator
5 attached to the end of the sheath to facilitate guiding the filter to the desired position for its release from the sheath. The closure device is adjustable to prevent any backflow of fluid such as blood from the assembly during the filter placement procedure.

10 United States Patent 5,397,307, to Goodin, teaches an intravascular material delivery dilation catheter having a pair of longitudinally spaced inflatable balloons with a drug delivery region defined therebetween. The catheter is ideally suited for use after a PTCA procedure, wherein the proximate balloon seals the blood vessel while the distal balloon is uniquely contoured when inflated to define fluid
15 communication paths therepast and proximate a blood vessel to be treated. The distal balloon, when inflated, has four lobes but could also be textured. Each lobe is separated from the next by a groove, which groove in combination with the blood vessel inner wall forms a fluid communication path therebetween. Upon inflation of both balloons in a blood vessel, a medicament such as heparin can be injected,
20 via the drug delivery region between the inflated balloons, wherein the medicament flows past the distal balloon at a selected rate. Accordingly, a medicament can be injected directly to a treatment site rather than injected as a bolus dose, thus, a smaller dosage may be employed to minimize side effects. Alternatively, perfusion can be accomplished by only partially inflating the proximate balloon to constrict
25 flow therepast, or eliminating the proximate balloon entirely, where the drug delivery region is disposed upstream of the contoured distal balloon,

United States Patent 5,370,614, to Amundson, et. al., teaches a balloon catheter includes a sheath surrounding the balloon, the sheath having a longitudinal
30 line of weakness and a drug-containing viscous matrix material intermediate between the balloon and the sheath such that when the balloon is positioned and

inflated in the body lumen it causes the sheath to burst at the line of weakness and release viscous matrix material onto said body lumen. The device provides accurate placement of the dosage required at the location in need of treatment. The catheter is especially useful in balloon angioplasty procedures.

5

United States Patent 5,338,301, to Diaz, teaches an extendable balloon-on-a-wire catheter which includes a telescoping exchange core wire mounted along the inside lumen of the longitudinal tube of the balloon-on-a-wire assembly. In the preferred embodiment, the exchange core wire is mounted within a hypodermic tube secured to the core wire of the balloon-on-a-wire assembly. A multiple component system includes this balloon-on-a-wire assembly together with an over-the-wire catheter which slidably passes over the elongated body of the balloon-on-a-wire assembly. Preferably, the relative sizing of these components of the system is such that the over-the-wire catheter does not pass over the balloon of the balloon-on-a-wire assembly. In a treatment procedure, the balloon-on-a-wire assembly achieves dilation of a lesion or a stenosis, after which it is moved somewhat distally to clear the stenosis. When the over-the-wire catheter is used, it is slidably moved over the balloon-on-a-wire assembly until its treatment location reaches the stenosis. During the procedure, the exchange core wire can be telescopically extended to a length such that the surgeon can readily grasp the balloon-on-a-wire assembly or its exchange core wire during manipulation of the over-the-wire catheter.

United States Patent 5,324,261, to Amundson, et. al., teaches a balloon catheter includes a sheath surrounding the balloon, the sheath having a longitudinal line of weakness and a drug-containing viscous matrix material intermediate between the balloon and the sheath such that when the balloon is positioned and inflated in the body lumen it causes the sheath to burst at the line of weakness and release viscous matrix material onto said body lumen. The device provides accurate placement of the dosage required at the location in need of treatment. The catheter is especially useful in balloon angioplasty procedures.

30

United States Patent 5,304,121, to Sahatjian, teaches a catheter and methods for delivering drug to tissue at a desired location of the wall of a body lumen. The catheter is constructed for insertion in a body lumen and has a catheter shaft and an expandable portion mounted on the catheter shaft. The expandable portion is expandable to a controlled pressure to fill the cross-section of the body lumen and press against the wall of the body lumen. In one embodiment, at least a portion of the exterior surface of the expandable portion is defined by a coating of a tenaciously adhered swellable hydrogel polymer. Incorporated in the hydrogel polymer is an aqueous solution of a preselected drug to be delivered to the tissue or plaque. The hydrogel polymer and drug are selected to allow rapid release of a desired dosage of the drug from the hydrogel polymer coating during compression of the hydrogel polymer coating against the wall of the lumen when the expandable portion is expanded. In other embodiments the polymer is released from the expandable portion in response to pressure, to coat the wall of the body lumen.

15

United States Patent 5,286,259, to Ganguly, et. al., teaches a catheter (10) having a stepped coaxial construction formed by an internal tube (12) and an external tube (14). The internal tube includes a distal pressure lumen (26), a balloon inflation lumen (28), and a sensor lumen (30). The external tube includes the first proximal pressure lumen (48), second proximal pressure lumen (50), injection lumen (52), and transducer lead lumen (54). A cylindrical transducer (16), sensor (18), and balloon (42) are supported on the internal and external tubes, which allow the transducer to be coaxially mounted thereon. The catheter has a high lumen count, large lumen cross-sectional area, is easy to construct and use, and allows cardiac output to be measured continuously without sacrificing other currently available catheter functions.

25

United States Patent 5,281,200, to Corso, Jr., et. al., teaches a balloon catheter system which includes a balloon-on-a-wire assembly and an over-the-wire catheter which slidably passes over the elongated body of the balloon-on-a-wire assembly, but not over its balloon. In the procedure by which the system is used,

30

the balloon-on-a-wire assembly achieves an initial dilation or predilation of a lesion or stenosis, after which it is moved somewhat distally to clear the predilated stenosis. The over-the-wire catheter then is slidably moved over the balloon-on-a-wire assembly until its balloon reaches and dilates the predilated stenosis. After
5 dilation is completed, the system is removed from the body vessel thus treated.

United States Patent 5,279,546, to Mische, et. al., teaches an apparatus and method for dissolving and removing material which tends to occlude a body passage way, such as an artery. The device employs a dual catheter system arranged in
10 coaxial fashion. Each of the catheters has an inflatable balloon at its distal tip. Inflating the two balloons occludes the body passage way both proximal and distal to the treatment area, thus isolating it from fluid contact with the rest of the body. Because concentric catheters are used, the distance between the balloons and hence the size of the treatment area is adjustable. The thrombolytic agent is
15 infused through orifices in the inner catheter in the region between the two balloons. A piezo electric device supplies ultrasonic agitation within the treatment area. A pressure device monitors the body passage way for unsafe conditions. Aspiration is accomplished through one or more lumens in the outer catheter. Ultrasonic agitation may be employed with the aspiration also to break up masses
20 of material which may be too big to pass through the exit lumen cross section.

United States Patent 5,254,089, to Wang, teaches an inflatable medical device for the delivery of medications to an organ in the body including a catheter having a plurality of lumens disposed therein. The distal end of the catheter is
25 adapted to be disposed within a bodily organ. A hollow, inflatable, medication-deliverable balloon is disposed on the distal end of the catheter and the interior of the balloon is in fluid flow relationship with one of the lumens to enable the balloon to be inflated. An array of conduits is disposed within the walls of the balloon for the delivery of medications to predetermined locations within said bodily organ.
30 Another lumen in the catheter shaft is provided to deliver medications to the conduits in the wall of the balloon and an egress for the medications so that they

may be dispensed at the site being treated.

United States Patent 5,236,417, to Wallis, teaches a cholangiography catheter for injecting dye into a cystic duct during laparoscopic cholangiography.

5 The catheter includes a bifurcated connector having a length of tubing and a check valve mounted to each arm of the connector. A saline syringe is coupled to one check valve and a dye syringe is coupled to the other check valve. The check valves and respective syringes are color coordinated to preclude inadvertently using the wrong syringe. The catheter is fabricated from a medical grade polymer having

10 a preselected degree of compliant memory and includes indicia for providing a visual indication of the depth of penetration of the tip of the catheter into the cystic duct.

United States Patent 5,226,427, to Buckberg, et. al., teaches a stylet for use with a retrograde cardioplegia catheter and its methods of use. The stylet includes

15 a stylet rod, a handle on the proximal end of the stylet rod and a predetermined curve in the distal end of the stylet rod. The handle has a thumb rest on the proximal end and a one or two finger loops extending outward from the handle. An obturator is located on the distal end of the predetermined curve to impede blood flow through tip of the cardioplegia catheter during insertion of the catheter. The

20 invention also contemplates methods for using the stylet.

United States Patent 5,209,723, to Twardowski, et. al., teaches a multiple lumen, intravenous catheter for hemodialysis or the like defines a distal end portion in which at least a pair of the catheter lumens each communicates with the exterior

25 through aperture means. By this invention the aperture means of one of the lumens defines a first port at essentially the distal catheter end, and the aperture means of the other of the lumens defines a second port spaced proximally along the catheter from the distal end and first port. The second port is positioned to face radially inwardly to at least a slight degree to avoid engagement of the wall of the blood

30 vessel that the catheter occupies. Additionally, the tip of the catheter distal of the second port is preferably of substantially helically shape, being sized to assist in

keeping the second port away from the blood vessel wall. As another feature, the catheter may be angled in its as-manufactured, unstressed condition to avoid pressing by elastic memory against internal blood vessel walls. Also, the catheter may define an inflatable balloon positioned between the first and second ports as
5 a means for spacing particularly the second port away from blood vessel walls.

United States Patent 5,209,717, to Schmoll, et. al., teaches a method and a device for the application and the removal of locally applied active substances against solid tumors, which device consists of a catheter (1) to be positioned
10 distally to the tumor for the collection of blood coming from the tumor, a pump (2) and a catheter (3) connected thereto and returning the blood into the body. The device is characterized in that between the two catheters (1, 3) there is present at least one container (4) capable of allowing blood to pass therethrough and containing immobilized substances having high affinity against the applied active
15 substance.

United States Patent 5,209,239, to Watanabe, et. al., teaches an apparatus for cystographic inspection used for observing and measuring the urethroptosis portion and posterourethovesical angle of a patient of the acraturosis caused by a
20 ventral pressure. The apparatus comprises a catheter, in the housing of which a flexible urethral locus indicating member, provided with a marking member, is positioned. The flexed condition of the urethral and the posterourethovesical angle can be clearly confirmed by the urethral locus indicating member, and the position of an exterior urethral opening member, and position of an exterior urethral opening
25 can be surely grasped by the marking member which can be roentgenographed and which is positioned on the urethral locus indicating member and that it is prevented from penetrating into the uretra and this assists in examining of the external urethral opening during roentgenography of the urethral locus indicating member of the catheter.

30

United States Patent 5,167,623, to Cianci, et. al., teaches a multilumen

catheter having a distal portion with a soft tip and reduced cross-section. The multilumen catheter of the present invention includes a flexible, elongated first catheter tube and a flexible, elongated, dual-lumen catheter tube which has a first and second lumens integrally formed and is disposed within the first catheter tube.

5 The cross-section of the dual-lumen catheter tube is smaller than that of the first catheter tube and therefore, an independent, single lumen is defined in the space between the first catheter tube and the dual-lumen catheter tube. The dual-lumen catheter tube extends beyond the distal end of the first catheter tube thereby providing an overall reduced cross-section of the distal portion of the present

10 multilumen catheter. Furthermore, the dual-lumen catheter tube may be formed from a softer material than that of the first catheter tube thereby providing a softer distal portion of the present multilumen catheter. A protective hub encapsulates and secures the proximal ends of the first and dual-lumen catheter tubes, and facilitates fluid communication between each of the lumens and fluid

15 transfer devices.

United States Patent 5,167,622, to Muto, a suction catheter provided with three conduits to provide the functions of suctioning, lavaging and oxygenating. The suction conduit is connected to a suction control member. The second conduit

20 for the irrigating fluid is connected to a source of said fluid. The third conduit is connected to a source of gas under pressure. The gas conduit terminates within the irrigation conduit to form a common chamber at the distal end of the irrigation conduit from which fluid is propelled out by the pressurized gas. The gas may preferably contain oxygen.

25

United States Patent 5,158,540, to Wijay, et. al., teaches a low-profile angioplasty catheter which is insertable through a guiding catheter. The angioplasty catheter has two balloons. The distal balloon dilates the stenosis. The proximal balloon is separately inflatable and selectively closes the annular passage

30 between the angioplasty catheter and the guiding catheter. The angioplasty catheter has a central lumen with a series of openings allowing fluid communication

from the central lumen into the annular passage proximally of the balloon which seals the annular passage. While the first balloon is inflated to dilate the stenosis, blood can be withdrawn from an arterial source through a lumen (or plurality thereof) in the guiding catheter and pumped into the annular passage between the angioplasty catheter and the guiding catheter. The blood then passes through the openings proximal to the proximal balloon into the central lumen of the PTCA catheter and flows beyond the distal tip of the angioplasty catheter to maintain circulation of the patient's blood at a point distal of the stenosis.

10 United States Patent 5,122,115, to Marks, teaches a multiple lumen catheter specifically adapted for selective visualization of one or the other of the coronary arteries. One lumen of the multiple lumen catheter is adapted to deliver contrast agent to the coronary artery to be visualized while a second, and optionally a third, lumen is adapted to limit flow of contrast agent to one or more other locations in the aortic root complex. The invention also includes a method of preparing for coronary angiography using such a catheter.

20 United States Patent 5,120,323, to Shockey, et. al., teaches a guide catheter system for use in the treatment of coronary artery disease includes a first single-lumen catheter of a relatively large internal diameter to pass a second guide catheter therethrough. The first guide catheter comprises an elongated flexible tube having a stainless steel braid embedded in the wall thereof for imparting desired torqueability characteristics to it. The first guide catheter is intended to be inserted at an appropriate point in the vascular system and then advanced until its distal end reaches the coronary ostium. The second guide catheter is fabricated by extruding a plastic, such as polyurethane thermoplastic resin over a tubular Teflon.RTM. core and because it is to be used within the lumen of the first catheter, it need not include a braided structure within its walls to prevent it from kinking. This allows the second catheter to be sufficiently slim to permit it to be advanced into a coronary artery while allowing fluids to be perfused between the outer wall of the second guide and the inner wall of the first guide catheter while still providing a

sufficiently large inner lumen to pass a working catheter, e.g., an angioplasty or atherectomy catheter. An atraumatic tip is attached to the distal end of the second guide catheter.

5 United States Patent 5,106,363, to Nobuyoshi, a dilation catheter defining a lumen and including a dilating member at the leading end, and a sheath defining a bore through which the dilation catheter is inserted to define a blood intake gap between the outer surface of the dilation catheter and the sheath bore and including a transverse bore branched from the sheath bore, a tube is connected at one end
10 to the transverse bore and at another end to the lumen of the dilation catheter at a trailing end. When the sheath having the dilation catheter inserted therein is set in a blood vessel, a pump in the tube operates to take blood into the blood intake gap in the sheath, pass through the tube and the dilation catheter lumen, and feed back to the periphery of a lesion through the open leading end of the dilation
15 catheter. The patient's own fresh blood can be injected without the need for a further cutdown or puncture for blood intake.

United States Patent 5,102,390, to Crittenden, et. al., teaches a balloon angioplasty system includes a balloon dilatation catheter having an inflation and
20 deflation lumen for the balloon and a main lumen extending the full length of the catheter to provide fluid communication from the proximal to the distal end of the catheter. A microdilatation probe has a small diameter and can be passed through the main lumen of the dilatation catheter. The microdilatation probe has a balloon at its distal end which is collapsible to enable it to be passed through the main
25 lumen of the dilatation catheter so that it can be projected distally beyond the distal tip of the dilatation catheter. The probe balloon is inflatable to a diameter no smaller than the diameter of the uninflated dilatation catheter. The probe and dilatation catheter are constructed so that fluid communication is maintained through the main lumen of the dilatation catheter while the microdilatation probe
30 extends through the catheter thereby enabling liquids to be infused and pressure measurements to be taken while the probe is in place. The probe may include a

distal tip which can hold a preset curve. In use, a stenosis which cannot be crossed by the dilatation catheter may be enlarged sufficiently to permit passage of the dilatation catheter by first projecting the dilatation probe into the stenosis, then inflating the probe balloon to enlarge the lumen of the stenosis sufficiently to thereafter receive the dilatation catheter.

United States Patent 5,084,031, to Todd, et. al., teaches a three-way double stopcock and associated tubing with which to connect both a cardioplegia solution source and a pressure monitor for the solution selectively and alternatively to either an antegrade cardioplegia catheter or a retrograde cardioplegia catheter. The stopcock includes a hollow valve body with three solution infusion ports communicating to the interior thereof in a coplanar arrangement at a first longitudinal point on the valve body. Three cardioplegia pressure monitoring ports also communicate through the valve body to the interior thereof at a second longitudinal position distinct from the first. Mounted in the valve body is a cylindrical valve core selectively rotatable about the longitudinal axis thereof between a first position in which the cardioplegia solution source and the pressure monitor are coupled to the antegrade cannula and a second position in which the cardioplegia solution source and the pressure monitor are coupled to the retrograde catheter. Formed in the valve core are a set of valving passageways for communicating with selective of the infusion ports and a set of valving passageways for communicating with selective of the pressure monitoring ports.

United States Patent 5,021,045, to Buckberg, et. al., teaches a retrograde cardioplegia catheter and its method of use. The catheter contains two lumens, an infusion lumen through which the cardioplegic solution flows and a pressure sensing lumen for monitoring the fluid pressure at the point where the solution exits the catheter. A slightly tapered, self-filling balloon is secured to the distal end of the catheter. Also, located at the distal end of the catheter is a soft, rounded tip to prevent damage to the sensitive intimal tissues of the coronary sinus. A stylet having a predetermined curve at the distal end and a handle at the proximal end is

removably located within the infusion lumen. The predetermined curve at one end of the stylet enables the cardioplegia catheter to be inserted quickly and accurately within the coronary sinus through a very small incision made in the right atrium. After the catheter is secured in place, the stylet is withdrawn. The catheter
5 remains in position for the duration of the operation in order to periodically readminister the cardioplegia solution.

United States Patent 5,004,455, to Greenwood, et. al., teaches a balloon catheter which comprises a balloon catheter body, a balloon, a main passage and
10 an auxiliary passage. The balloon is provided on the periphery of the tip portion of the catheter body to inflate for blocking a bloodstream at a desired site inside blood vessels. The auxiliary passage is provided for inflating the balloon. The main passage is provided behind the balloon, having an opening to eject a drug. The tip portion of the balloon catheter is inserted into one of branches of the blood vessel
15 near targeted affected part. A fluid is injected into the balloon so that the balloon blocks a bloodstream in the branches. Therefore, a drug is ejected through the main passage of the balloon catheter into other branches.

United States Patent 4,883,459, to Calderon, teaches the study of tumors
20 in the body of a patient *in situ* by a monitor, such as computer assisted tomography, X-ray or the like, while optimal flow paths through the tumor area are established. A catheter with a suction lumen and an infusion lumen, with seals associated with each, is placed in the patient's vein near the tumor. Flow is then sealed in the vein with the infusion seal. A carrier medium dye is injected into the
25 tumor at selected flow rates and differential pressures. Flow of the dye through the tumor is observed on the monitor to determine optimal retrograde perfusion paths through the tumor for the selected flow rates and differential pressures. Once the optimal perfusion paths are noted, a preferential attack area in the tumor is located using a different, less dense carrier dye and increased fluid back pressure in the
30 infusion system. Once the attack area in the tumor is located, microspheres with active ingredients, such as chemotherapy, can be selectively perfused through one

of the paths in the tumor to the attack site and forced into the tumor, once at the attack site, using increased back pressure. The process may be cyclically repeated using the same or different active ingredients. The procedure may be repeated through the tumor in different paths and attack points at desired active ingredient dosages using increased back pressures.

United States Patent 4,867,742, to Calderon, teaches the study of tumors in the body of a patient *in situ* by a monitor, such as computer assisted tomography, X-ray or the like, while optimal flow paths through the tumor area are established. A catheter with a suction lumen and an infusion lumen, with seals associated with each, is placed in the patient's vein near the tumor. Flow is then sealed in the vein with the infusion seal. A carrier medium dye is injected into the tumor at selected flow rates and differential pressures. Flow of the dye through the tumor is observed on the monitor to determine optimal retrograde perfusion paths through the tumor for the selected flow rates and differential pressures. Once the optimal perfusion paths are noted, microspheres with active ingredients, such as chemotherapy, can be selectively perfused through each of the paths in the tumor at desired flow rates, pressures and active ingredient dosages. Alternatively, microspheres with different active ingredients can be selectively introduced through the tumor in different paths at desired active ingredient dosages and established flow rates and pressures.

United States Patent 4,820,261, to Schmoll, et. al., a device for the removal of active substances locally applied against solid tumors consists of a catheter (1) to be positioned distally to the tumor for the collection of blood coming from the tumor, a pump (2) and a catheter (3) connected thereto and returning the blood into the body. The device is characterized in that between the two catheters (1, 3) there is present at least one container (4) capable of allowing blood to pass therethrough and containing immobilized antibodies against the applied active substance.

United States Patent 4,714,460, to Calderon, teaches catheter feedback methods and systems for optimizing the infusion of a drug, such as a chemotherapeutic agent via retrograde perfusion through the venous side of the vascular network to a selectively determined portion of a solid tumor. Monitoring and regulatory capability are provided for controlling the outflow of the drug and thereby for controlling the dose rate, the duration of exposure of the drug, the leakage factor, and the level of systemic toxicity, all critical factors in the successful treatment of solid tumors. A feedback loop for practicing the method comprises two concentric balloon catheters capable of extensive maneuvering and selective placement within the venous drainage of the vascular system, creating a third in-vivo space for repeated perfusion of the selected portion of a diseased organ as often as desired, providing maximum exposure of the chemotherapy to the tumor with minimum exposure to any other portions of the patient's body.

Cancerous tumors, occur in various sizes and shapes in substantially all parts of a patient's body, and are thus fed by a diversity of blood vessels. Typically blood is fed to a tumor from an artery. The blood passes through the tumor and is received by a vein for eventual recirculation back to the patient's heart. Blood may be received from the tumor through a plurality of inlets over a length of the vein. Prior art apparatuses and processes similar to the instant invention, have been for the most part tailored to tumors occurring in various organs, i.e., most particularly, the liver, which have well defined feed arteries and veins. Despite the plethora of such prior art apparatuses and processes, there has hitherto been no effective manner to vary the length over which the vein may be blocked by the double balloons of a typical double balloon catheter defining the isolated portion of the patient's body from which blood contaminated with chemo-therapeutic would be withdrawn. Thus, there has been a long felt need for an apparatus and process by which such a isolated length of vein can be varied

SUMMARY OF THE INVENTION

It is the primary object of the instant invention to accommodate the long felt need for an apparatus and process for varying the isolated length of a vein receiving blood flowing from a tumor which has been contaminated with chemo-therapeutic agents.

The instant invention in large part solves the problems of the prior and fulfills a long felt need by varying the length over which the vein receiving contaminated blood from a treated tumor, is isolated from the remainder of the patient's blood circulatory system.

The instant invention provides a novel apparatus for varying the length over which the vein receiving contaminated blood from a treated tumor, is isolated from the remainder of the patient's blood circulatory system.

The instant invention provides a novel method for using a novel apparatus for varying the length over which the vein receiving contaminated blood from a treated tumor, is isolated from the remainder of the patient's blood circulatory system.

The instant invention provides a novel catheter and a novel method of its use.

The instant invention provides a novel catheter and a novel method of using the catheter for varying the length over which the vein receiving contaminated blood from a treated tumor, is isolated from the remainder of the patient's blood circulatory system.

Here are the more important features of the invention as broadly outlined, in order that the detailed description that follows may be better understood; and in

order for the present contribution to the art may be better appreciated. There are additional features of the invention that will be described hereinafter and which form the subject matter of the appended claims. Those of ordinary skill in the art will appreciate that the conception upon which this disclosure is based may readily
5 be utilized as a basis for the designing of other structures, methods and systems for carrying out the several purposes of the instant invention. It is important, therefore, that the claims be regarded as including such equivalent constructions insofar as they do not depart from the spirit and scope of the instant invention.

10 Further, the purpose of the instant abstract is to enable the U.S. Patent and Trademark office and the public generally, and especially the scientists, engineers and practitioners in the art who are not familiar with patent or legal terms or phraseology, to determine quickly from a cursory inspection of it, the technical disclosure of the patent application. The abstract is neither intended to define the
15 invention of the instant patent application, which is measured by the claims, nor is it intended in any manner to be limiting as to the scope of the instant invention

In light of the foregoing, it is therefore an object of the instant invention to provide a new and improved apparatus and process which has all of the advantages
20 of the prior art and none of its disadvantages.

It is another object of the instant invention to provide a new and improved apparatus and process which may be easily and efficiently manufactured and marketed.
25

It is another object of the instant invention to provide a new and improved apparatus which is of a durable and reliable construction.

It is another object of the instant invention to provide a new and improved
30 apparatus which can be manufactured at correspondingly lower cost with regard to both labor and materials, and which accordingly can be sold at a correspondingly

lower cost, thus promoting commerce.

It is a further object of the instant invention to provide a new and improved apparatus and method which provides at least some of the advantages of the prior art schemes, while simultaneously eliminating at least some of the disadvantages of them.

It is a further object of the instant invention to provide a new and improved apparatus and process which is particularly designed for varying the length over which the vein receiving contaminated blood from a treated tumor, is isolated from the remainder of the patient's blood circulatory system.

Other objects, features, and advantages of the instant invention, in its details of construction and arrangement of parts, will be seen from the above, from the following description of the preferred embodiment when considered in light of the drawings and the appended claims.

BRIEF DESCRIPTION OF THE DRAWINGS

FIG. 1 depicts the basic apparatus of the invention as shown in relationship to a tumor in the body of a patient.

FIG. 2 depicts a diagrammatic of an apparatus assembly for carrying out the process of the invention.

FIG. 3 depicts a partial cross-sectional side view of a first alternative embodiment of a double balloon catheter as contemplated by the invention.

FIG. 4 shows a cross-sectional end view of the shaft of the double balloon catheter of FIG. 3.

FIG. 5 shows a cross-sectional end view of the midsection of a modification of the double balloon catheter of FIG. 3

FIG. 6 shows a partial cross-sectional side view of another design of double balloon catheter useful in the process of the invention,

FIG. 7 shows a cross-sectional end view of the shaft of the double balloon catheter of FIG. 6.

FIG. 8 shows a cutaway cross-sectional side view of the interior of the novel double balloon catheter having a slidable balloon, encompassed by the invention.

FIG. 8a shows an exploded cutaway cross-sectional side view of the interior of the slidable balloon of FIG. 8, positioned to provide a spacing midway between the maximum and minimum spacings between the two balloons.

FIG. 8b shows an exploded cutaway cross-sectional side view of the interior of the slidable balloon of FIG. 8, slid into the position providing maximum spacing between the two balloons.

FIG. 8c shows an exploded cutaway cross-sectional side view of the interior of the slidable balloon of FIG. 8, slid into the position providing minimum spacing between the two balloons.

DETAILED DESCRIPTION OF THE DRAWINGS

FIG. 1 shows the basic apparatus used to practice the process of the instant invention in relationship to tumor within the body a patient. The practitioner first determines the length of the blood vessel 7 which receives substantially all blood typically from a plurality of other smaller blood vessels which provide a plurality of flow paths from the tumor 3 to the blood vessel 7. Prior to insertion of the double

balloon catheter (9) into blood vessel 7, the slidable balloon is slid into a position to enable isolation of all of the plurality of flow paths by the two balloons of the balloon catheter. The balloon catheter is then inserted into and positioned within vessel 7 sufficiently to isolate all of the plurality of flow paths after the two
5 balloons (11, 12) the double balloon catheter (9) are inflated. Balloons (11, 12) are thereupon inflated and tumor 3 is thereafter infused with cancer therapy drugs from syringe 4 through tubing leading to catheter 6 located in blood vessel 5. The blood passing through the blood vessel 5 containing concentrations of chemotherapeutic agent lethal to the cancer cells of the tumor 3, is passed via the blood vessel 7 to
10 the double balloon catheter (9) located in IVC 1. The balloons of the double balloon catheter (9) are positioned central and peripheral of the blood vessel 7. The balloons (11, 12) are critically designed, sized and spaced such that after inflation, they can accommodate the geometric constraints, including the length of the particular blood vessel over which substantially all blood which has been
15 contaminated with chemotherapeutic agents is received from the tumor 3. Substantially all of the contaminated blood is passed through the double balloon catheter (9) to tubing 17 to a point exterior to the body 2, to a pump 21. Typical of such a pump is a Bio Medicus BP-50 Bio-Pump having a priming volume of 48 mL, containing two rotator cones and providing a maximum flow rate of 5 liters per
20 minute. Pump 21 passes the blood through the extracorporeal circuit at relatively constant low pressure. The purpose in doing so is to avoid raising or lowering the fluid pressure of the total circuit ranging from the blood vessel through the return to the body. The contaminated blood is thereafter passed through tubing 41 into detoxification zone 43. Typical of such a detoxification zone is a hemoperfusion
25 cartridge containing activated carbon. Suitable cartridge systems are obtainable from Clark Research and Development, Inc., New Orleans, La. 70121 and from Gambro Dialysatoren KG, d-7450 Hechingen, Federal Republic of Germany AUT 224 (sold under the trademark of ADSORBA.RTM.). The detoxified blood is passed through tube 44 and infused back into the body of the patient through, i.e., a
30 subclavian vein (not shown) by conventional procedures typical of the prior art. Other alternatives to the subclavian vein contemplated by the invention are: the

superior vena cava, a jugular vein or the right atrium.

FIG. 2 shows the schematic relationship between the tumor 3, the blood vessel(s) 5 feeding the tumor 3, and the blood vessel 1, through which toxified blood is passed through the tumor. Double balloon catheter 9 comprises central balloon 11 and slidable peripheral balloon 12, each in juxtaposition to cylindrical fenestration zone 8. Zone 8 contains fenestrations 13 sufficient in total area to allow the complete removal of the toxified blood flow from the tumor into the catheter 9. The hollow interior (main lumen) of catheter 9 is of sufficient size to completely remove the blood from the blood vessel without elevating blood pressure. Catheter 9 is provided with channel 15 that is used to inject fluid into the balloons 11 and 12 for inflation or to withdraw fluids for deflation. The venous flow is passed through catheter 9 into openly connected tube 17. Tube 17 may be interrupted by a pressure monitor the same as assembly A, discussed below, that is later provided in the extracorporeal circuit. Tube 17 may alternatively be connected directly with pump 21 or to Y-fitting 19, as shown. Also connected to Y-fitting 19 is ancillary feed system B comprising tube 23, Y-fitting 25, and multiple IV spikes 29 and 33 each connected to tubes 30 and 31 respectively, and each is provided with a clamp, 27 and 28, respectively. These lines can be used for the introduction of medications as required

Typically, pump 21 is a smooth rotator pump design and a particularly desirable pump is a Bio Medicus RP-50 Bio-Pump having a priming volume of 48 ml, containing two rotator cones and providing a maximum flow rate of 5 liters per minute. The contaminated blood is gently pushed between the smooth rotators 37 in zones 35 and issued from the pump through port 39 into tube 41. Tube 41 is connected to cartridge or canister 43 containing a meshed sack of activated carbon particles coated with an acrylic resin containing heparin, see Clark, supra. The outflow from cartridge 43 is fed to tube 45 and then to tube 47 that is connected to pressure monitoring assembly A. Pressure monitoring assembly A comprises a pressure monitor gauge 55 connected to fluid membrane vessel 53 that contains

a thin membrane that separates the gauge 55 from the blood in vessel 53 and responds to the fluid pressure of the blood in vessel 53. That response is read by the gauge. Vessel 53 is connected to tubing 57, that is connected to stopcock 52. Stopcock 52 is connected to flexible tubing 59 that in turn is connected to
5 stopcock 51, the latter secured in fitting 49.

Blood from tubing 47 is passed to Y-connector 63 via tubing 61, then to tubings 65 and 67. Tubings 65 and 67 are each connected to catheter 69 and another catheter (connected to tube 65) not shown. These catheters are provided
10 for returning the purified blood to the subclavian veins

FIG. 3 depicts a double balloon catheter design typically having up to a 24 French (Fr) O.D. Zone 100 is provided with slotted fenestrations 104 in the solid plastic tubing 102. The open end 118 terminates the catheter. End 118 is tapered
15 to the caliber of an angiographic guide wire that will, under fluoroscope control, allow the catheter to be advanced from the femoral vein to the proper location in the inferior vena cava without risk of injury to the interior of the vessels. Appropriate guide wires may be, for example, 0.035, 0.038, or 0.045 inch in diameter. During treatment, the catheter end hole is closed using a standard
20 angiographic apparatus (tip-occluding wire), that consists of a thin wire long enough to traverse the length of the catheter at the end of which is a stainless steel bead just large enough to obstruct the catheter's end-hole when advanced into it (similar to a metal stopper that closes the outlet from a sink when advanced).

25 Alternatively, the end hole can be made 7-12 Fr in diameter in order to accommodate a return catheter. The return catheter can be used to return treated blood to the systemic circulation. The return catheter is advanced over a guide wire through the main lumen of the double balloon catheter and through the end hole 118 into the right atrium or superior vena cava. The return catheter can be
30 made to gradually taper its O.D. by decreasing its wall thickness, leaving the I.D. constant, since the location of the tip of the return catheter is not critical. The

length over which the catheter tapers is arbitrary. The taper is constructed so that the tip of the catheter is its narrowest O.D. and the O.D increases toward the femoral vein. As this return catheter is advanced through the lumen of the main catheter the tip easily passes through the end hole 118 of the double balloon catheter. The tapered end of the return catheter is advanced until it obstructs the end hole 118, preventing systemic blood from entering the double balloon catheter when the balloons are inflated but leaving an open lumen through the return catheter to return blood beyond the isolated venous segment without mixing with contaminated blood.

10

The catheter tubing (body) can be made of a variety of plastic materials such as polypropylene, polyethylene, polyvinylchloride, ethylene vinylacetate copolymers, polytetrafluoroethylene, polyurethane, and the like. A favorable plastic combination for catheters containing a return lumen are a homogeneous mixture of high density polyethylene and linear low density polyethylene. That combination gives favorable stiffness at ambient conditions and allows the use of especially thin wall thicknesses. When the surface of the catheter is made of a plastic that is difficult to bond with a balloon, the plastic may be treated first by one or more of a number of well known methods that make bonding possible. The methods include plasma treatment, ozone treatment, and the like. Slidable balloon 110 and fixed 114 may be made from a plurality of elastomeric materials such as latex rubber, polyurethanes, spandex type polyurethanes, EPDM rubber, and the like. The balloons are typically adhesively bonded at sheath surfaces 108 and 112, respectively. A wide variety of adhesives may be employed. Polyacrylonitrile type adhesives, rubber latex adhesives and the like may be used to secure the balloon to the sheath surfaces 108 and 112.

15

20

25

30

FIG. 4 depicts a cross section of a typical catheter design such as that shown in FIG. 3. The interior of the catheter contains main lumen 120 and 4 additional lumina 124 molded into the outer wall 122. The additional lumina can be used for the various functions described above.

FIG. 5 depicts a cross section of an alternate embodiment of the catheter of the instant invention similar to that shown in FIG. 3, but containing only three lumina. The interior of the catheter contains main lumen 130 and two supplementary lumina 131 molded into segment 133 of wall 135. The supplementary lumina can be used for the various functions described above.

FIG. 6 depicts yet another alternate embodiment of the double balloon catheter of the instant invention, which can have an outside diameter of 24 French such as in the fenestration zone 140 and an inside diameter of less than 22 Fr. Zone 140 is provided with slotted fenestrations 141 in the plastic tubing 142.

FIG. 7 depicts a cross sectional view of still yet another embodiment of the catheter of the instant invention showing a main lumen 150 and 3 supplemental lumina 151.

FIG. 8 provides a more detailed schematic cross sectional side view of a typical double balloon catheter 161 which illustrates the primary substance of the instant invention. In this depiction, the catheter sidewall 163 is penetrated by a plurality of fenestrations 165. The main lumen 169 contains at its periphery supplemental lumina 170, 171 and 173. Supplemental lumen 170 can be used to accommodate a guidewire, supplemental lumen 171 can be used to accommodate a pressure monitor, and supplemental lumen 173 is used to supply fluid to slidable balloon 166 and fixed balloon 167 through openings 175 and 177.

FIG. 8a depicts a blown up cutaway view of slidable balloon 166 including a fluid tight seal 178; wherein the slidable balloon 166 has been slid along the outer tube of catheter 161 to a position midway between the positions providing maximum and minimum distances between slidable balloon 166 and fixed balloon 167.

FIG. 8b depicts a blown up cutaway view of slidable balloon 166 which has

been slid along the outer tube of catheter 161 to a position which provides maximum spacing between slidable balloon 166 and fixed balloon 167.

FIG. 8c depicts a blown up cutaway view of slidable balloon 166 which has
5 been slid along the outer tube of catheter 161 to a position which provides minimum spacing between slidable balloon 166 and fixed balloon 167.

Prior to the instant invention, no effective or practical method and/or
apparatus existed for accommodating the length over which a blood vessel received
10 toxified blood from an infused tumor. Thus, common to all of the double balloon catheter embodiments of the instant invention is the critical "customized" sizing and spacing of the respective elements thereof, in accommodation to the varied sizes and dimensions of: the particular tumor to be treated, and the blood vessel which withdraws the blood therefrom, and in particular the adjustable spacing
15 between the two balloons which is enabled by the slidable balloon.

The term "tumor," as used herein, also spelled TUMOUR, also called NEOPLASM, a mass of abnormal tissue that arises without obvious cause from preexisting body cells, has no purposeful function, and is characterized by a
20 tendency to autonomous and unrestrained growth. Tumors are quite different from inflammatory or other swellings because the cells in tumors are abnormal in their appearance and other characteristics. Abnormal cells--the kind that generally make up tumors--differ from normal cells in having undergone one or more of the following alterations: (1) hypertrophy, or an increase in the size of individual cells;
25 this feature is occasionally encountered in tumors but occurs commonly in other conditions; (2) hyperplasia, or an increase in the number of cells within a given zone; in some instances it may constitute the only criterion of tumor formation; (3) anaplasia, or a regression of the physical characteristics of a cell toward a more primitive or undifferentiated type; this is an almost constant feature of malignant
30 tumors, though it occurs in other instances both in health and in disease.

The term "cancer," as used herein refers to any one of a group of more than 100 related diseases characterized by the uncontrolled multiplication of abnormal cells in the body. If this multiplication of cells occurs within a vital organ or tissue, normal function will be impaired or halted with possible fatal results. Tumors, which primarily occur with the advent of cancer, are classified as malignant or benign; intermediary forms exist, however, and benign bone tumor may present therapeutic problems because of its location. Primary bone tumors are characterized by their origin in the skeletal tissue elements, for example, bone tissue tumors (the malignant osteogenic sarcoma and the benign osteoma), cartilage tumors (the malignant chondrosarcoma and the benign chondroma), bone marrow tumors (the malignant myeloma and the benign eosinophilic granuloma). Metastatic (secondary) tumors are malignant by definition and are characterized by their site of origin. Typically, tumors occurring in an extremity occur in the form of i.e., a bone lesion. A bone lesion is a malignant growth of the bone caused by metastatic spread from cancer in other organs. Primary bone cancer is fairly uncommon, but bone lesions from metastases are seen in more than half of all cancer patients at the time of death. There are two types of metastatic bone lesion: osteoblastic, in which new bone is laid down in a disorganized fashion, and osteolytic, in which bone is destroyed, causing fractures and deep bone pain. Lung, breast, kidney, and prostate cancers are the primary tumors that most commonly cause bone lesions; lung cancer causes a typical punched-out lytic lesion while breast and prostate tumors more often produce osteoblastic metastases. Bone lesions commonly occur in the vertebral column, ribs, and pelvis, as well as in the long bones of the arms and legs.

25

The term "detoxification," and its variants, as used herein, includes, but is not necessarily limited to: cascade membrane plasmapheresis, hemodialysis, hemoperfusion, membrane plasmapheresis, peritoneal dialysis, single-needle dialysis, hemosorption, hemoperfusion, regular peritoneal dialysis, recirculating peritoneal dialysis, continuous ambulatory peritoneal dialysis (CAPD), hemoultrafiltration, hemofiltration, blood centrifugation, and the like.

30

The invention is particularly applicable to muscle tumors. Muscle tumors are abnormal tissue growth located in or originating from muscle tissue. Tumors may either arise in muscle tissue or spread to it. Three major tumor types may appear; they are known as leiomyomas, rhabdomyomas, and rhabdomyosarcomas.

5

The invention is also particularly useful in treating i.e., osteoclastoma also called GIANT-CELL Tumor OF BONE, a bone tumor found predominantly in the knee region, but also occurring in the wrist, hand, foot, arm, and pelvis. The giant cells (large, often multinucleated cells) found in these tumors resemble osteoclasts, for which the tumor is inappropriately named. Usually seen in young adults between the ages of 20 and 40, this relatively uncommon, painful tumor is considered potentially malignant. Most tumors are benign at the outset and are removed by curettage (scraping). Unfortunately, about 50 percent of the tumors removed in this way recur, of which a small percentage spread to other parts of the body (metastasize). Until now, this has prompted some physicians to recommend more aggressive treatment, such as complete excision or amputation.

10
15

20

The term "means" [and its variants], as used herein, means: any and/or all equivalent structure which when manipulated, will render the claimed function.

25

The term "process" or "method" [and its variants] as used herein, means: (1) a natural phenomenon marked by gradual changes that lead toward a particular result (2) : a natural continuing activity or function; *or*, a series of actions or operations conducing to an end; *or*, especially a continuous operation or treatment especially in manufacture.

Although the invention has been described with reference to certain preferred embodiments, it will be appreciated that many variations and modifications may be made within the scope of the broad principles of the invention. Hence, it is intended that the preferred embodiments and all of such variations and modifications be included within the scope and spirit of the invention, as defined
5 by the following claims.

The embodiments of the invention in which an exclusive property or privilege is claimed are defined as follows:

- 5 1. In an apparatus for treating a tumor in the body of a patient, including a first catheter designed, sized and dimensioned for percutaneous insertion into the blood vessel receiving the blood from said tumor, further including (a) a plastic tube having a cranial end and a caudal end, said plastic tube defining a main lumen for outflowing blood, a first balloon and a second balloon, spaced apart about said plastic tube and for inflation thereabout, said first
10 balloon being contiguous to said cranial end; wherein said balloons are sized and spaced on said plastic tube sufficient, that when inflated, they have sufficient size and spacing therebetween to isolate substantially all of the flow of toxified blood from said tumor and within said blood vessel; fenestrations in said plastic tube between said balloons to said main lumen;
15 second and third lumina within said plastic tube; said second lumen connecting to one of said first balloon and said second balloon; and, said third lumen connecting to the other of said first balloon and said second balloon, for effecting inflation or deflation of said balloons; said cranial end of said plastic tube being closed to substantially all inflow of blood; and, a
20 second catheter for returning blood removed through said main lumen to the patient, the improvement comprising:

25 structure for enabling said second balloon to slide along said plastic tube between a first position defining a minimum distance between said first balloon and said second balloon, and a second position defining a maximum distance between said first balloon and said second balloon.

- 30 2. The apparatus of claim 1, wherein said cranial end is tapered to a diameter of an angiographic guide wire.
3. The apparatus of claim 2, wherein said plastic tube has a fourth lumen sized

to accommodate an angiographic guide wire.

4. The apparatus of claim 1, wherein said second and third lumina connect and are common to the interiors of said balloons.

5

5. The apparatus of claim 1, wherein said second and third lumina lie within the wall of said plastic tube.

10

6. The apparatus of claim 1, wherein said second balloon further comprises a fluid tight seal position between said second balloon and said plastic tube.

7. A double balloon catheter comprising:

a first fixed balloon on the cranial end of said catheter;

15

a second slidable balloon positioned around said catheter and spaced from said first fixed balloon; and,

20

structure for enabling said second balloon to slide along said plastic tube between a first position defining a minimum distance between said first balloon and said second balloon, and a second position defining a maximum distance between said first balloon and said second balloon.

25

8. The apparatus of claim 7, wherein said second balloon further comprises a fluid tight seal position between said second balloon and said plastic tube.

9. The apparatus of claim 7, wherein said second balloon further comprises a fluid tight seal position between said second balloon and said plastic tube

30

10. The apparatus of claim 7, wherein said catheter further comprises a first stop for constraining the sliding distance of said second balloon to a position

corresponding to a maximum distance between said first balloon and said second balloon.

5 11. The apparatus of claim 7, wherein said catheter further comprises a second stop for constraining the sliding distance of said second balloon to a position corresponding to a minimum distance between said first balloon and said second balloon.

10 12. A method for the isolated infusion chemotherapeutic agents into a tumor, comprising:

locating the blood vessel which receives substantially all blood which passes through said tumor;

15 determining the total length of said blood vessel which receives said substantially all blood;

20 providing a double balloon catheter which includes a first fixed balloon on the cranial end of said catheter; a second slidable balloon positioned around said catheter and spaced from said first fixed balloon; and, structure for enabling said second balloon to slide along said plastic tube between a first position defining a minimum distance between said first balloon and said second balloon, and a second position defining a maximum distance between said first balloon and said second balloon;

25 sliding said second balloon to a position on said catheter sufficient to provide a distance between said first balloon and said second balloon larger than said total length;

30 inserting said catheter into said blood vessel to a point sufficient to isolate said total length from the remainder of the blood circulatory system of said

patient;

infusing chemotherapeutic agents into said tumor; and;

- 5 extracorporeally withdrawing substantially all blood toxified by said chemotherapeutic agents from said tumor through said catheter from between said first balloon and said second balloon.

FIG. 1

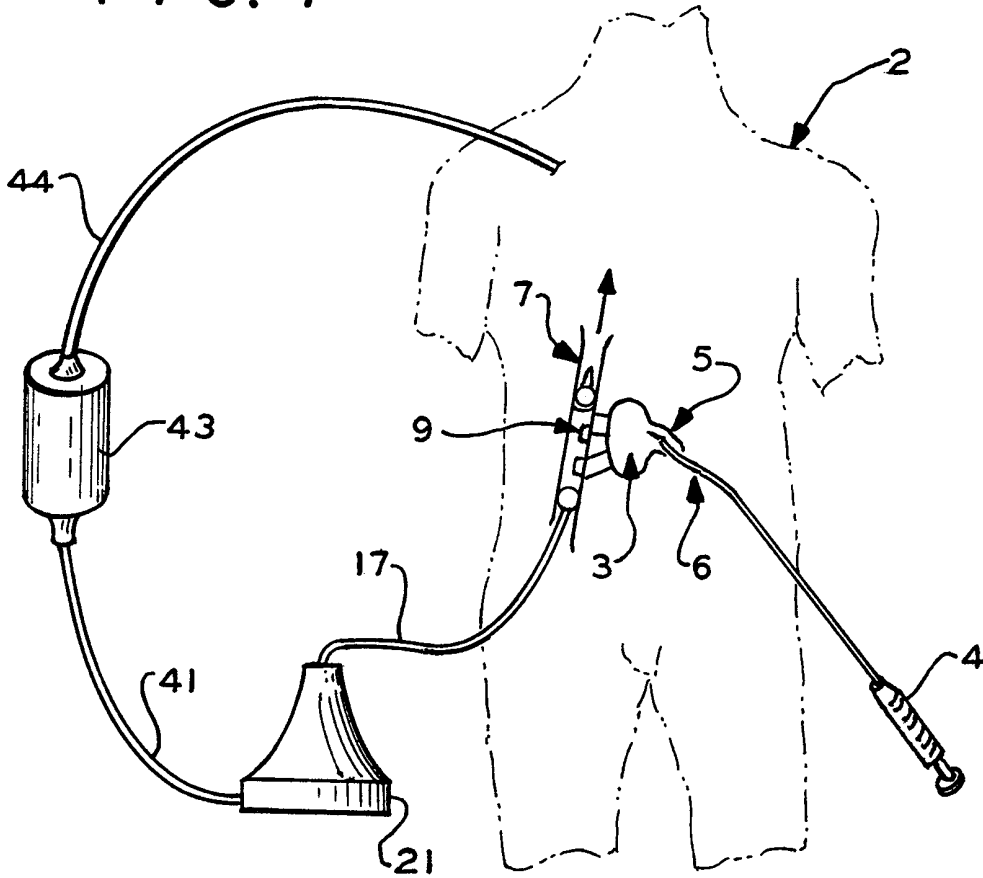

FIG. 6

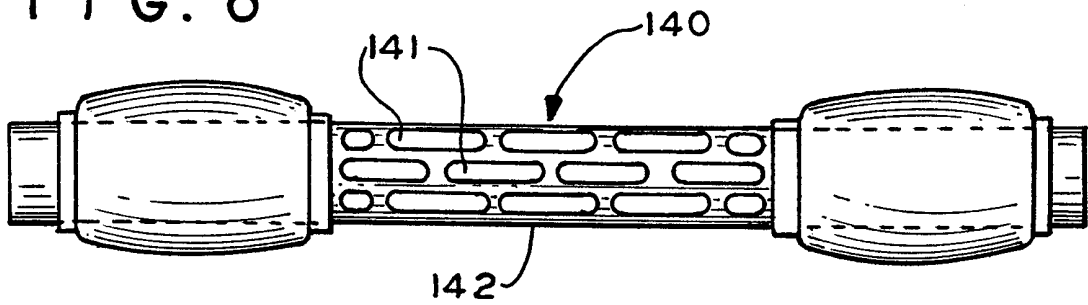
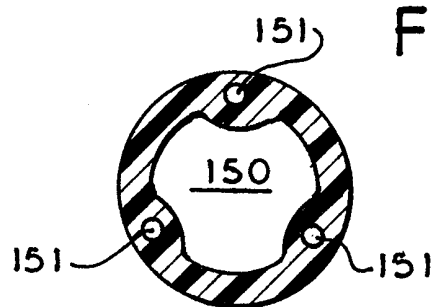

FIG. 7



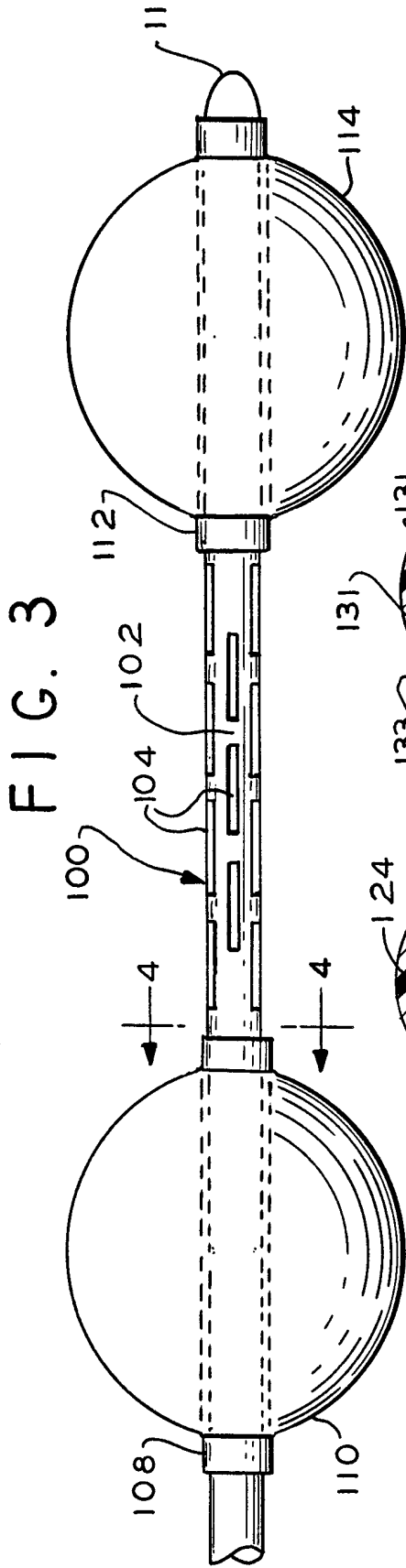

FIG. 3

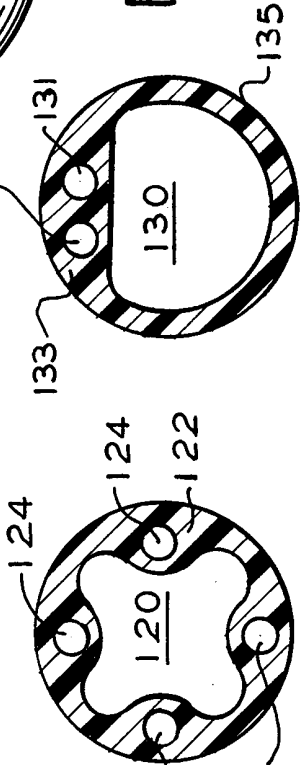

FIG. 5

FIG. 4

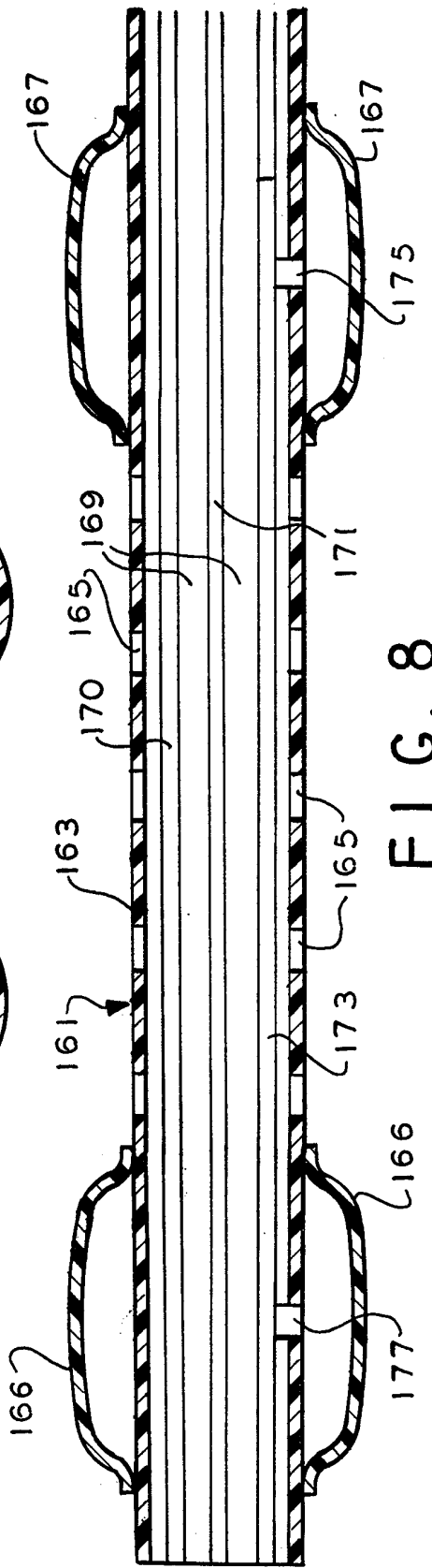

FIG. 8

FIG. 8A

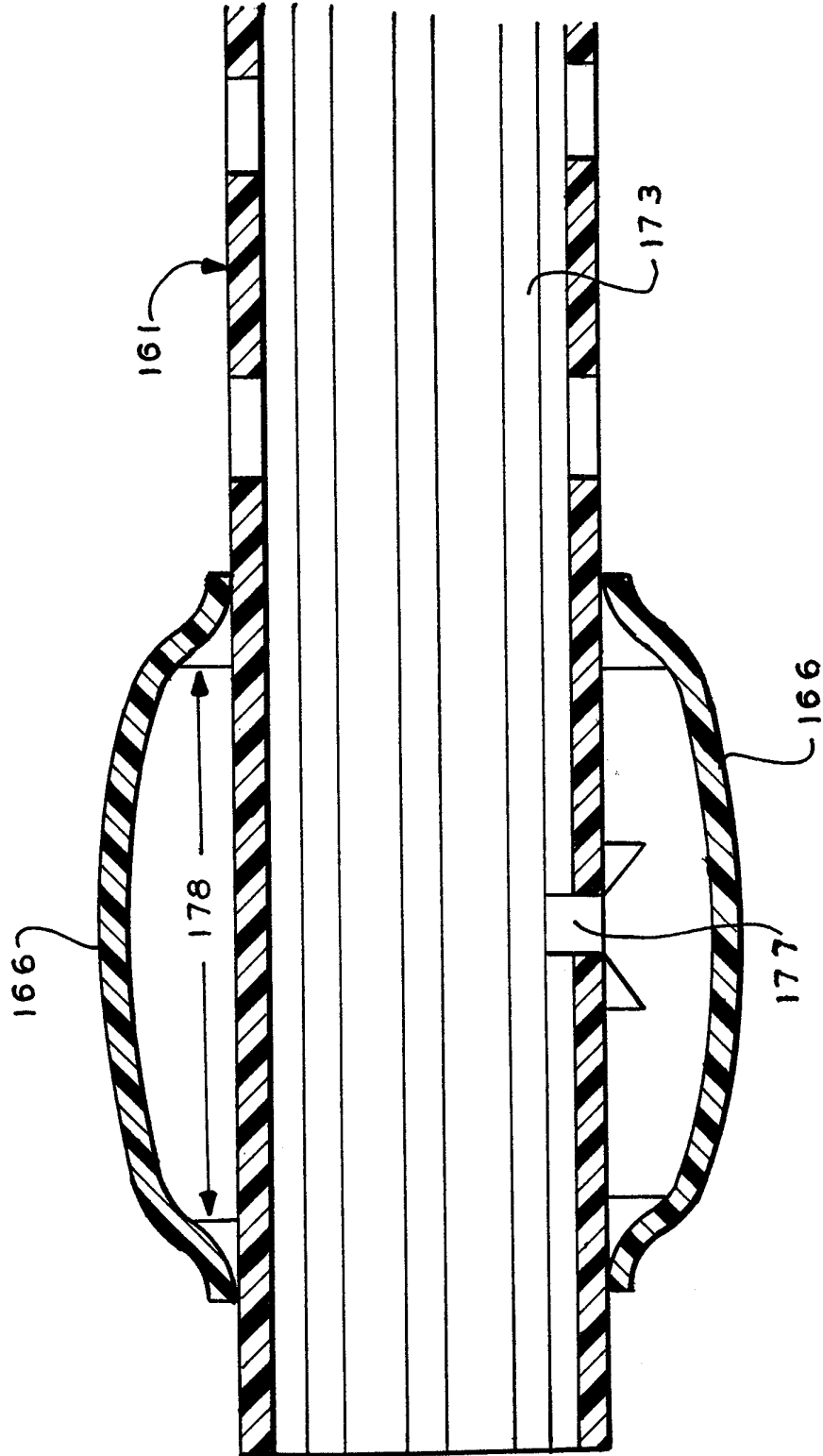

FIG. 8B

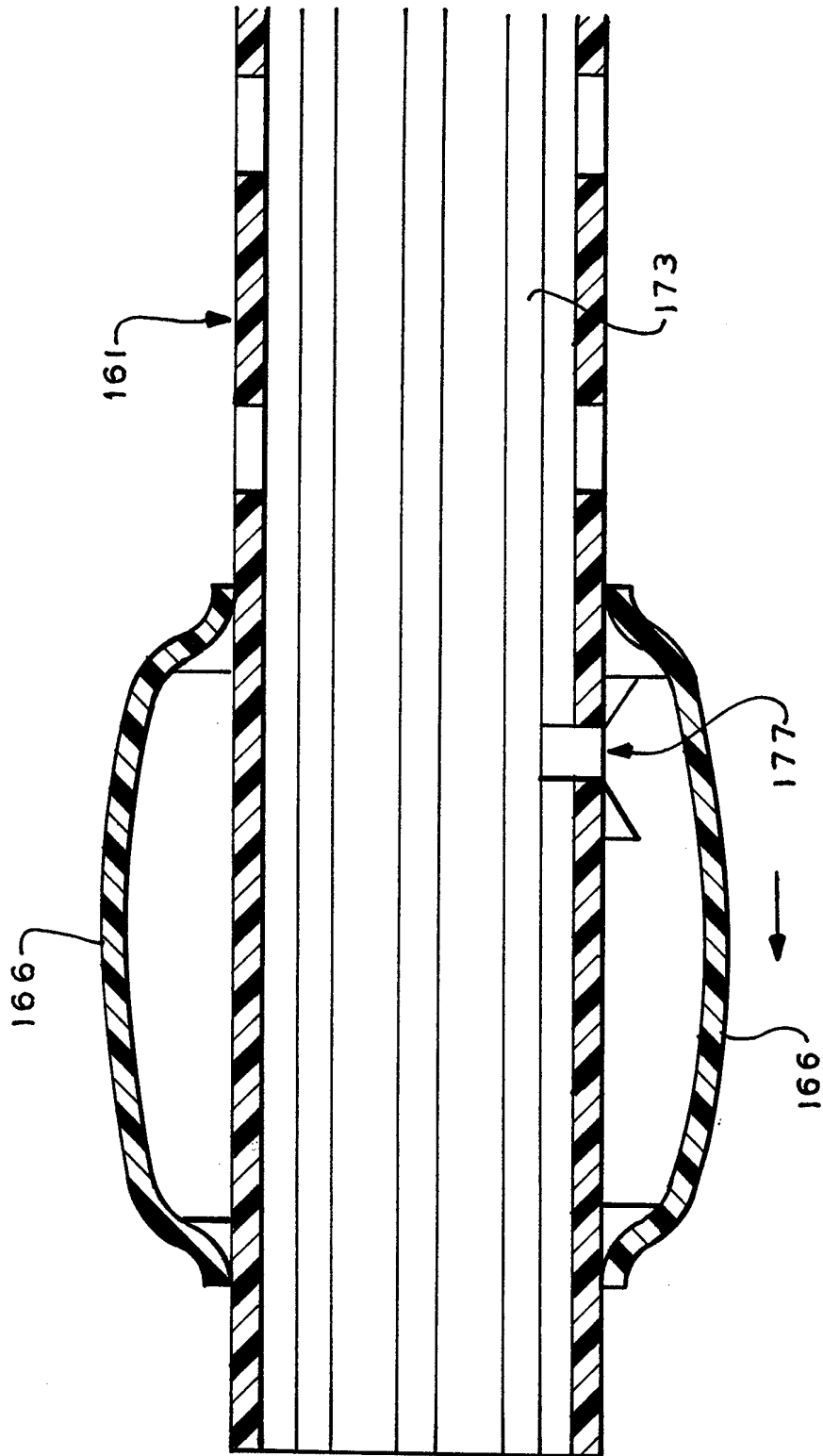

FIG. 8C

