



(19) **United States**

(12) **Patent Application Publication**
Currivan et al.

(10) **Pub. No.: US 2008/0291980 A1**

(43) **Pub. Date: Nov. 27, 2008**

(54) **CANCELLATION OF INTERFERENCE IN A COMMUNICATION SYSTEM WITH APPLICATION TO S-CDMA**

(60) Provisional application No. 60/367,564, filed on Mar. 26, 2002, provisional application No. 60/151,680, filed on Aug. 31, 1999.

(75) Inventors: **Bruce J. Currivan**, Dove Canyon, CA (US); **Thomas J. Kolze**, Phoenix, AZ (US); **Gottfried Ungerboeck**, Langnau (CH); **Nabil R. Yousef**, Foothill Ranch, CA (US)

Publication Classification

(51) **Int. Cl.**
H04B 1/707 (2006.01)
(52) **U.S. Cl.** **375/148**

Correspondence Address:
GARLICK HARRISON & MARKISON
P.O. BOX 160727
AUSTIN, TX 78716-0727 (US)

(57) **ABSTRACT**

Cancellation of interference in a communication system with application to S-CDMA. A relatively straight-forward implemented and computationally efficient approach of selecting a predetermined number of unused codes is used to perform weighted linear combination selectively with each of the input spread signals in a multiple access communication system. If desired, the predetermined number of unused codes is always the same in each implementation. Alternatively, the predetermined number of unused codes is selected from within a reordered code matrix using knowledge that is shared between the two ends of a communication system, such as between the CMs and a CMTS. While the context of an S-CDMA communication system having CMs and a CMTS is used, the solution is generally applicable to any communication system that seeks to cancel narrowband interference. Several embodiments are also described that show the generic applicability of the solution across a wide variety of systems.

(73) Assignee: **Broadcom Corporation, a California Corporation**, Irvine, CA (US)

(21) Appl. No.: **11/522,839**

(22) Filed: **Sep. 18, 2006**

Related U.S. Application Data

(63) Continuation of application No. 10/142,189, filed on May 8, 2002, now Pat. No. 7,110,434, which is a continuation-in-part of application No. 09/652,721, filed on Aug. 31, 2000, now Pat. No. 6,778,611.

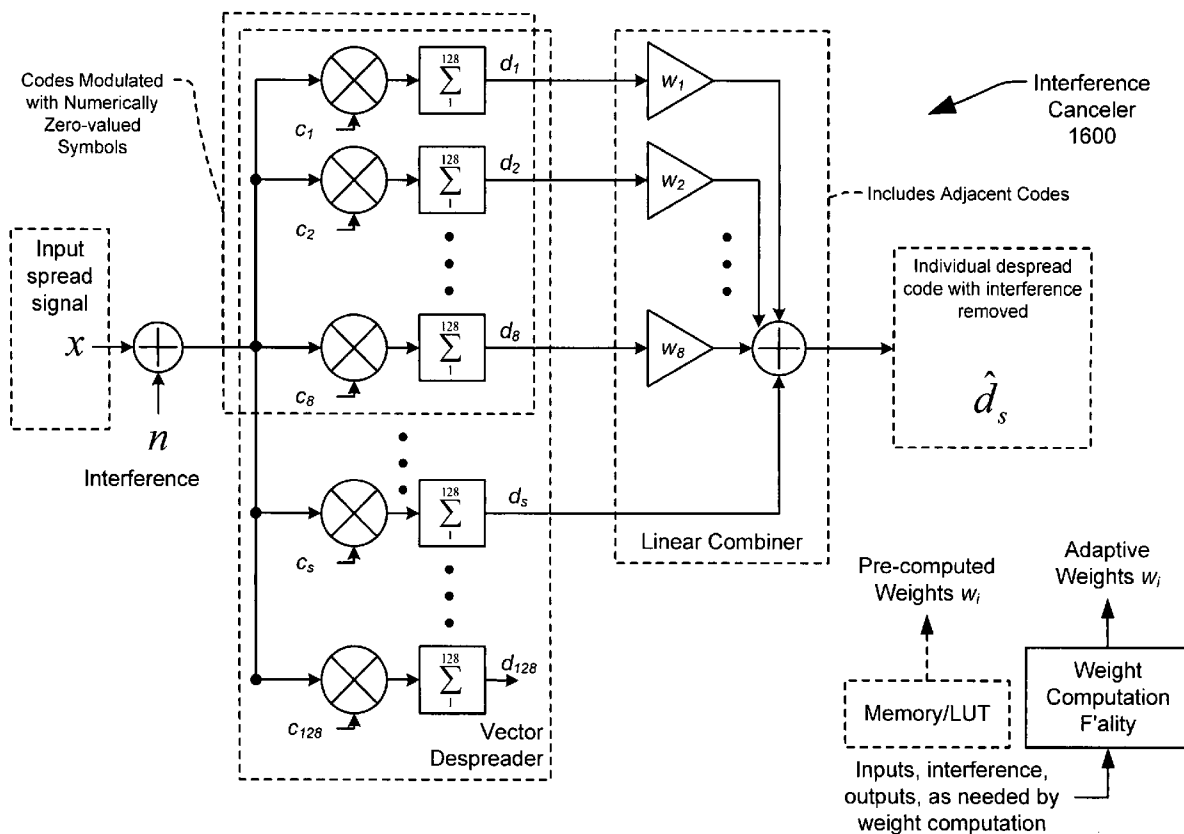

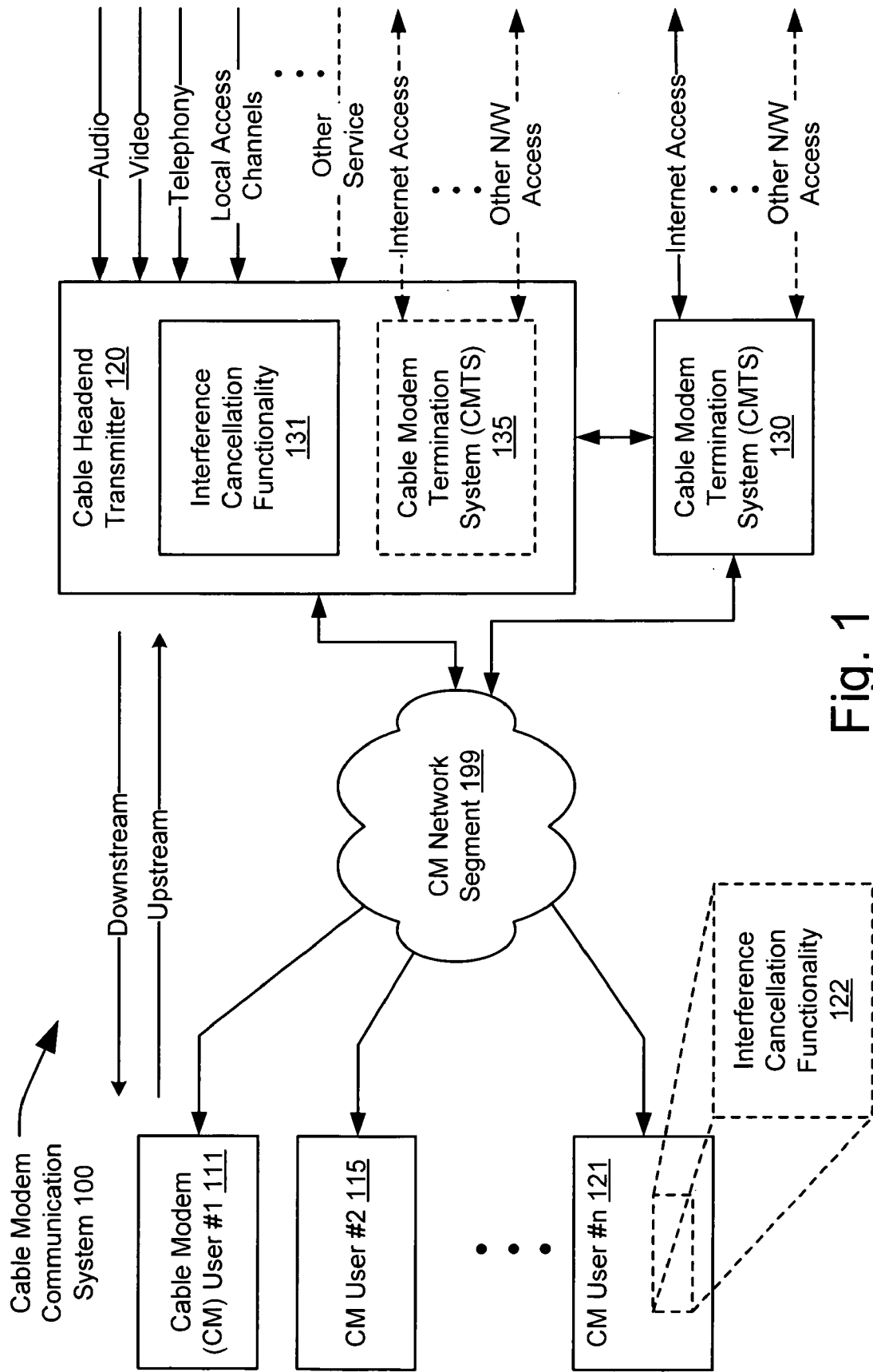

Fig. 1

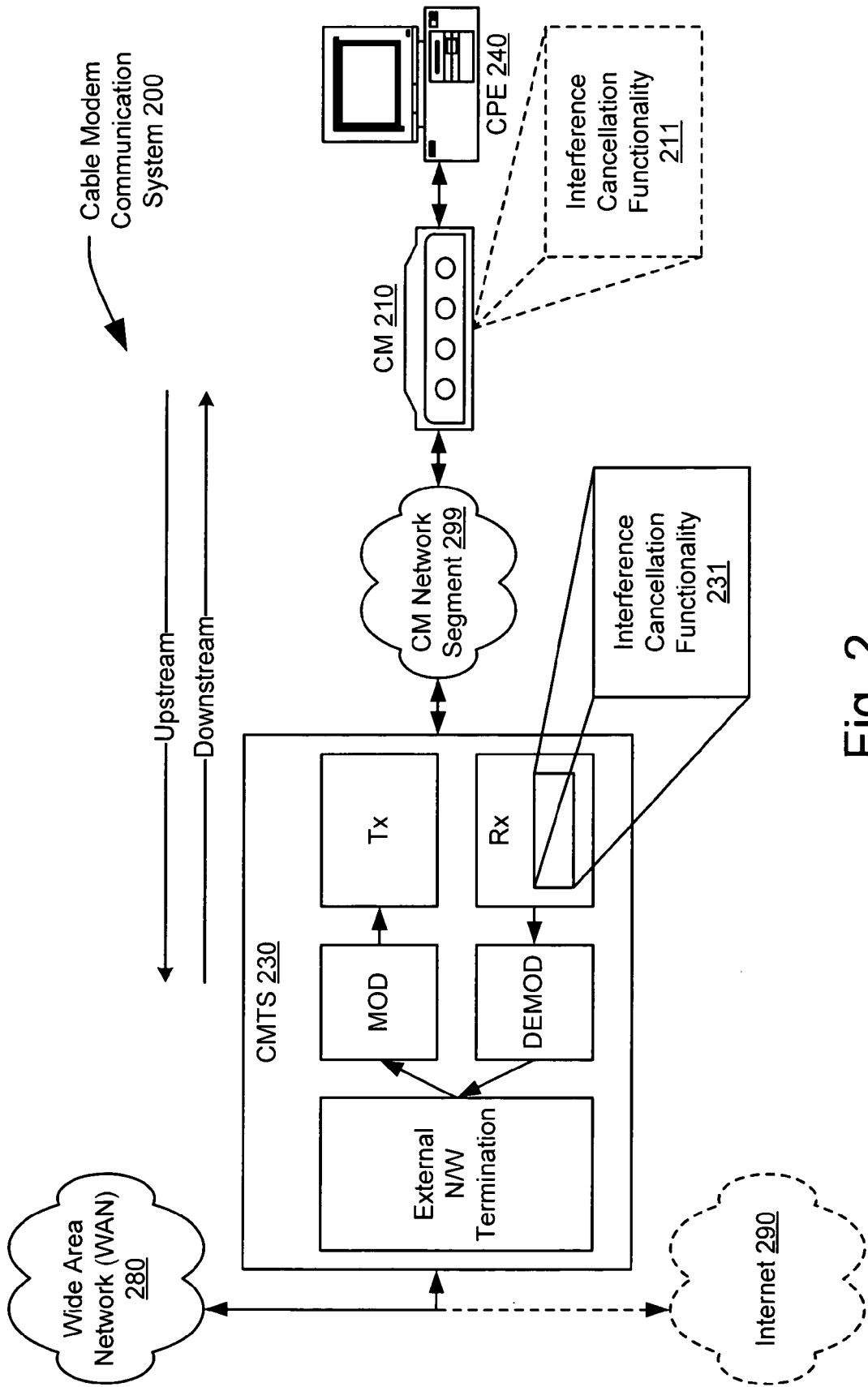

Fig. 2

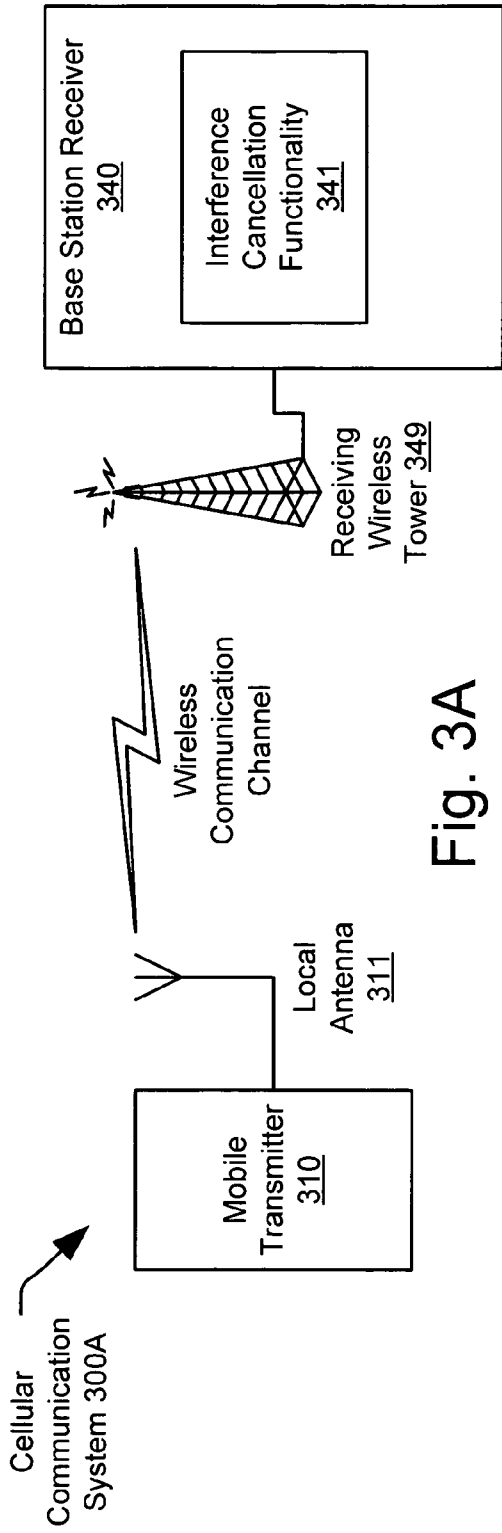

Fig. 3A

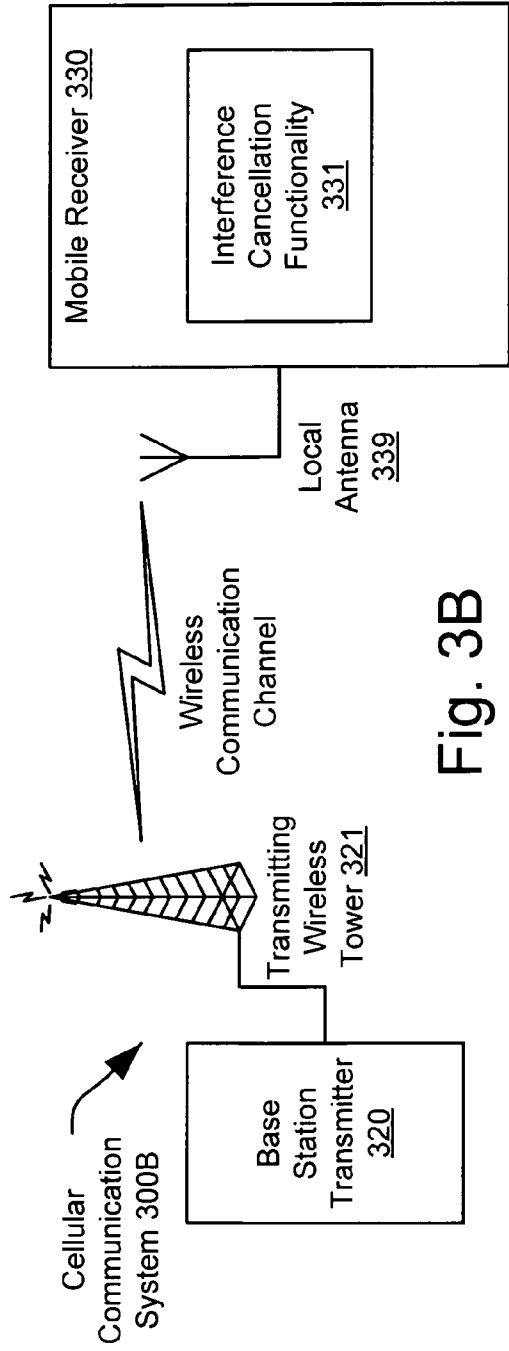

Fig. 3B

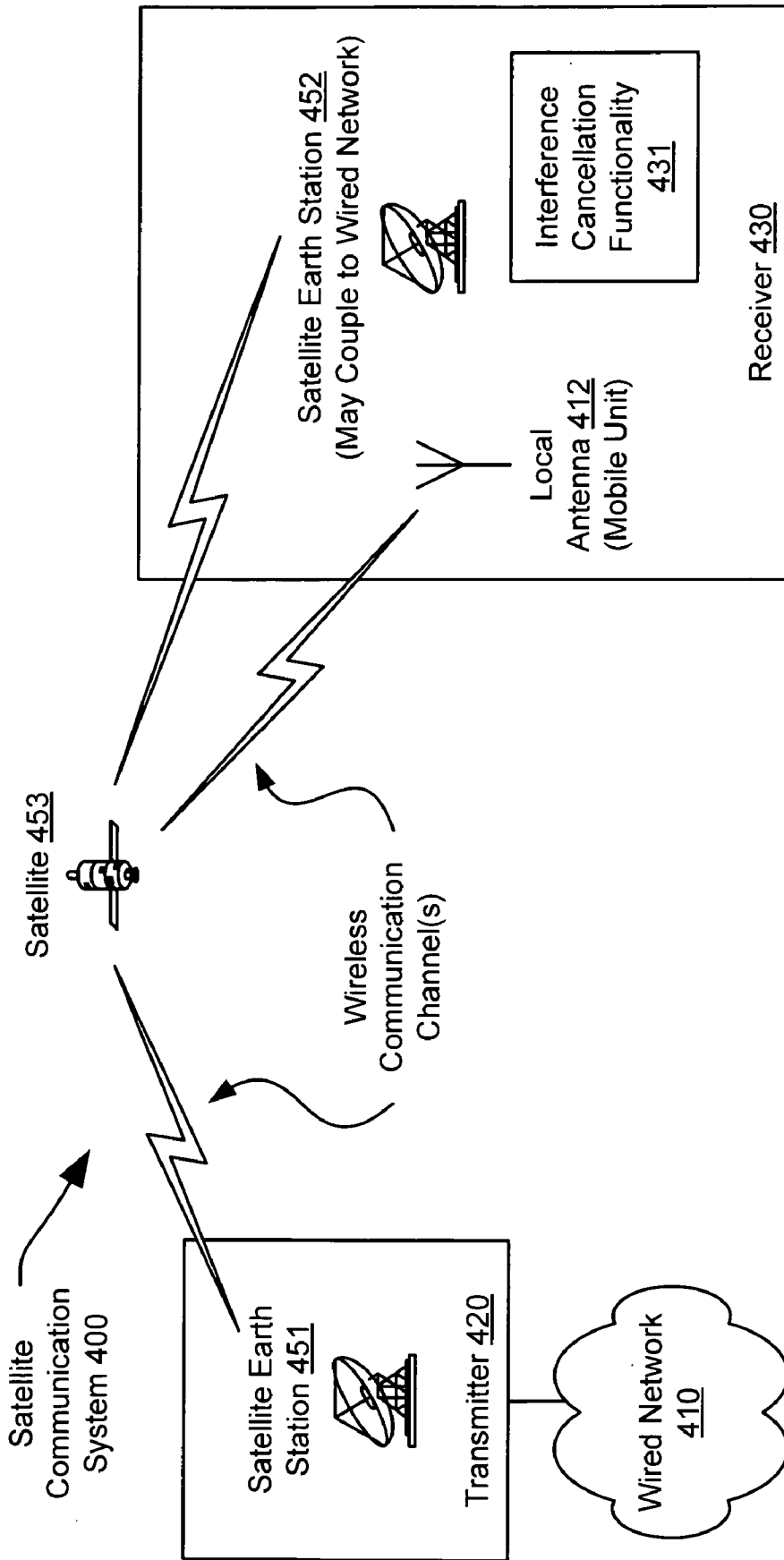

Fig. 4

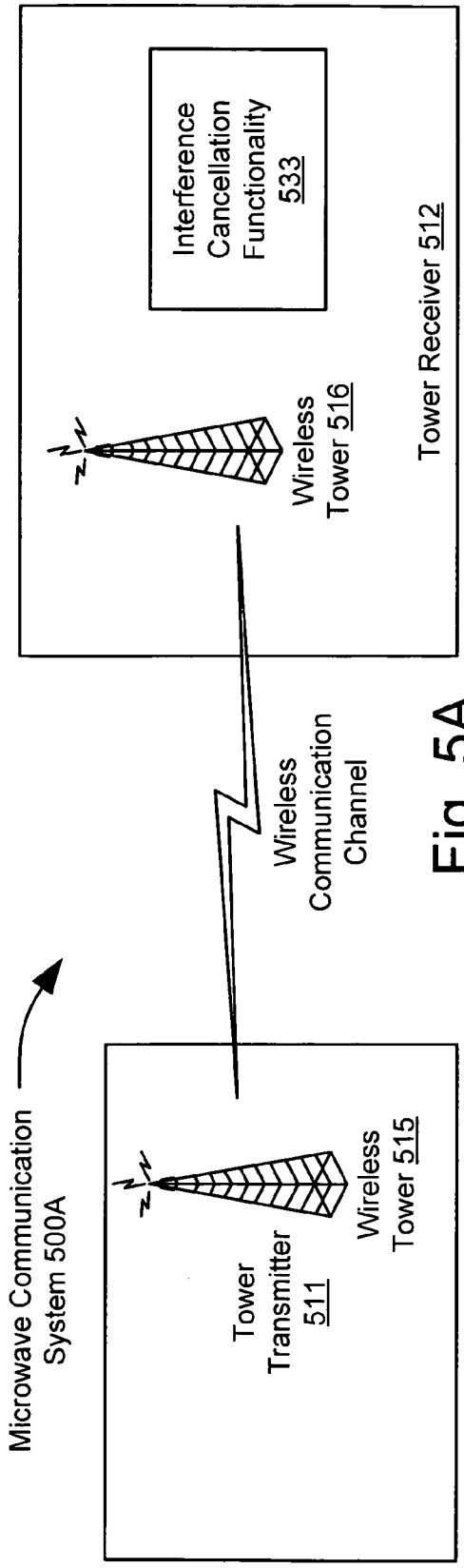

Fig. 5A

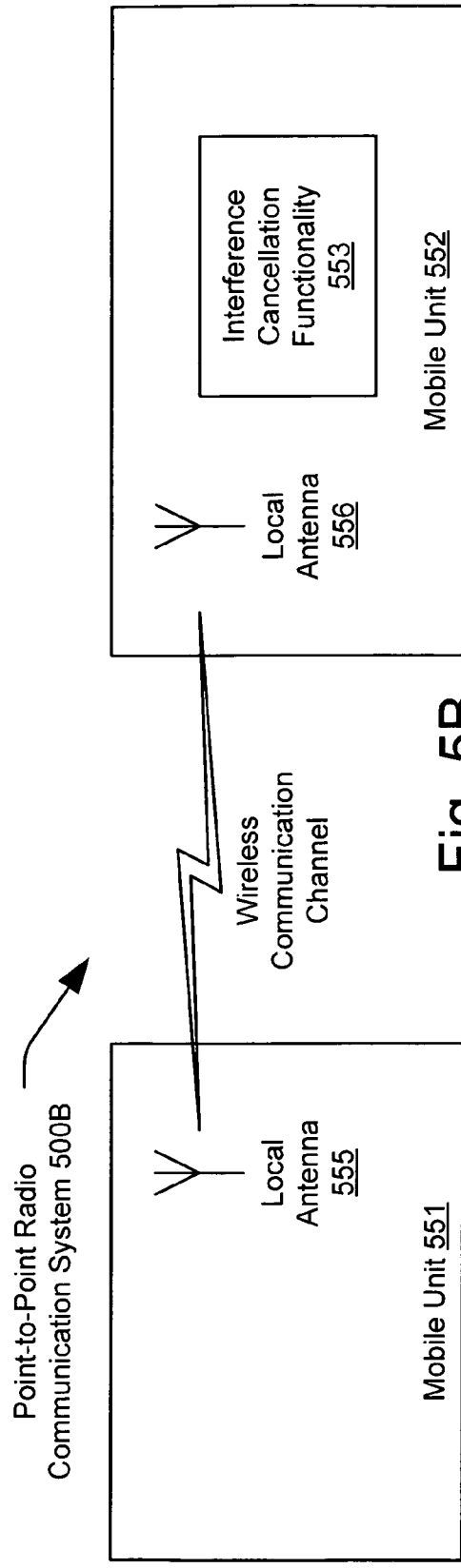

Fig. 5B

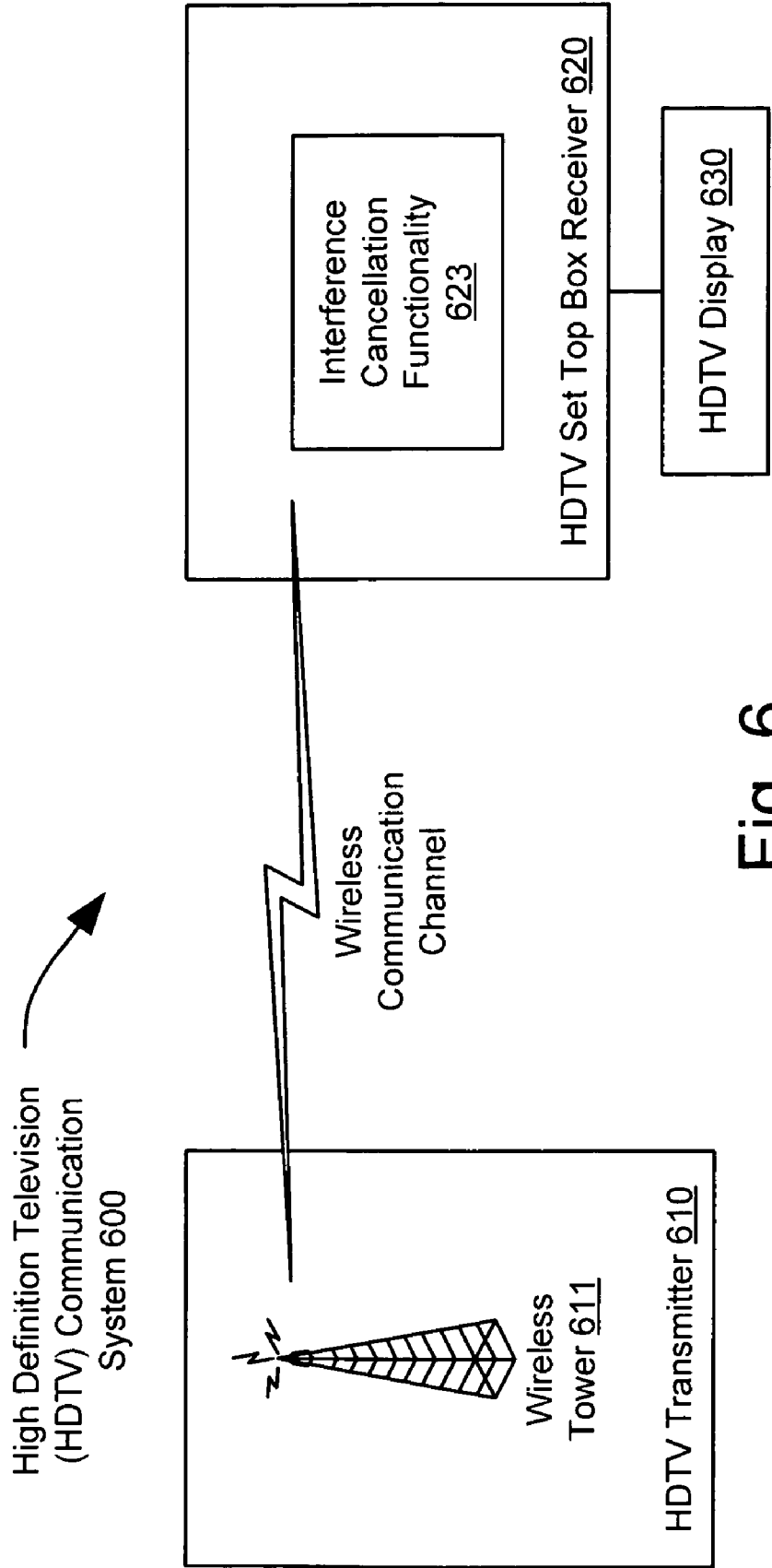

Fig. 6

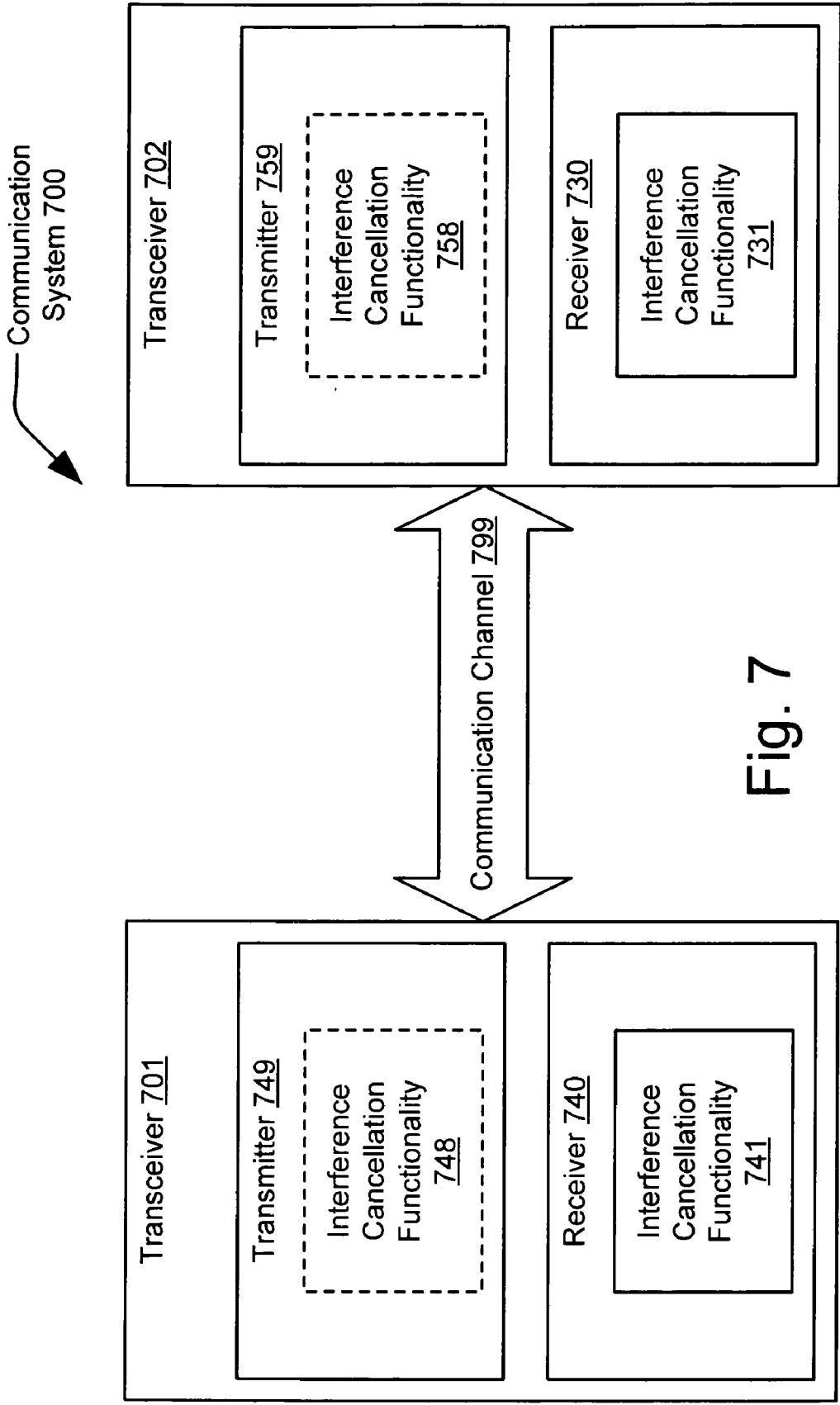

Fig. 7

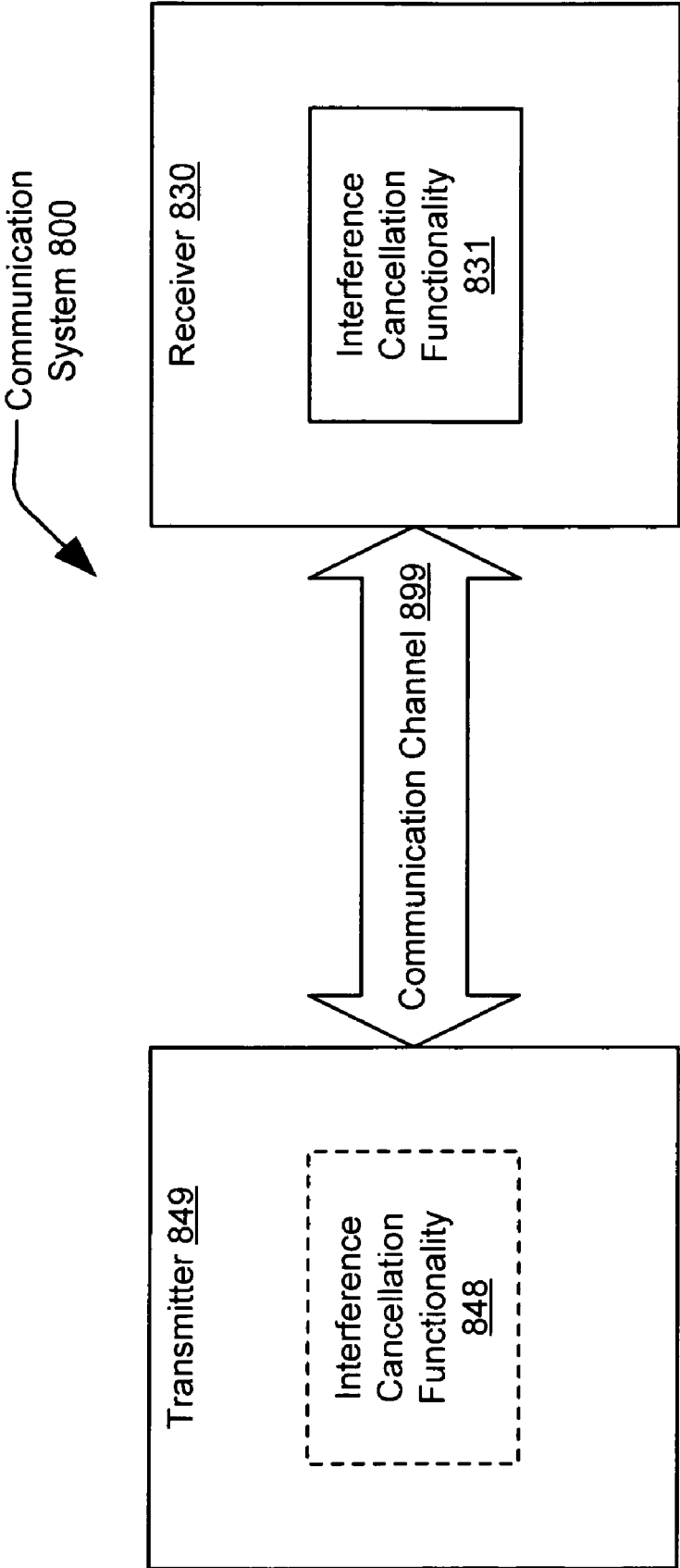

Fig. 8

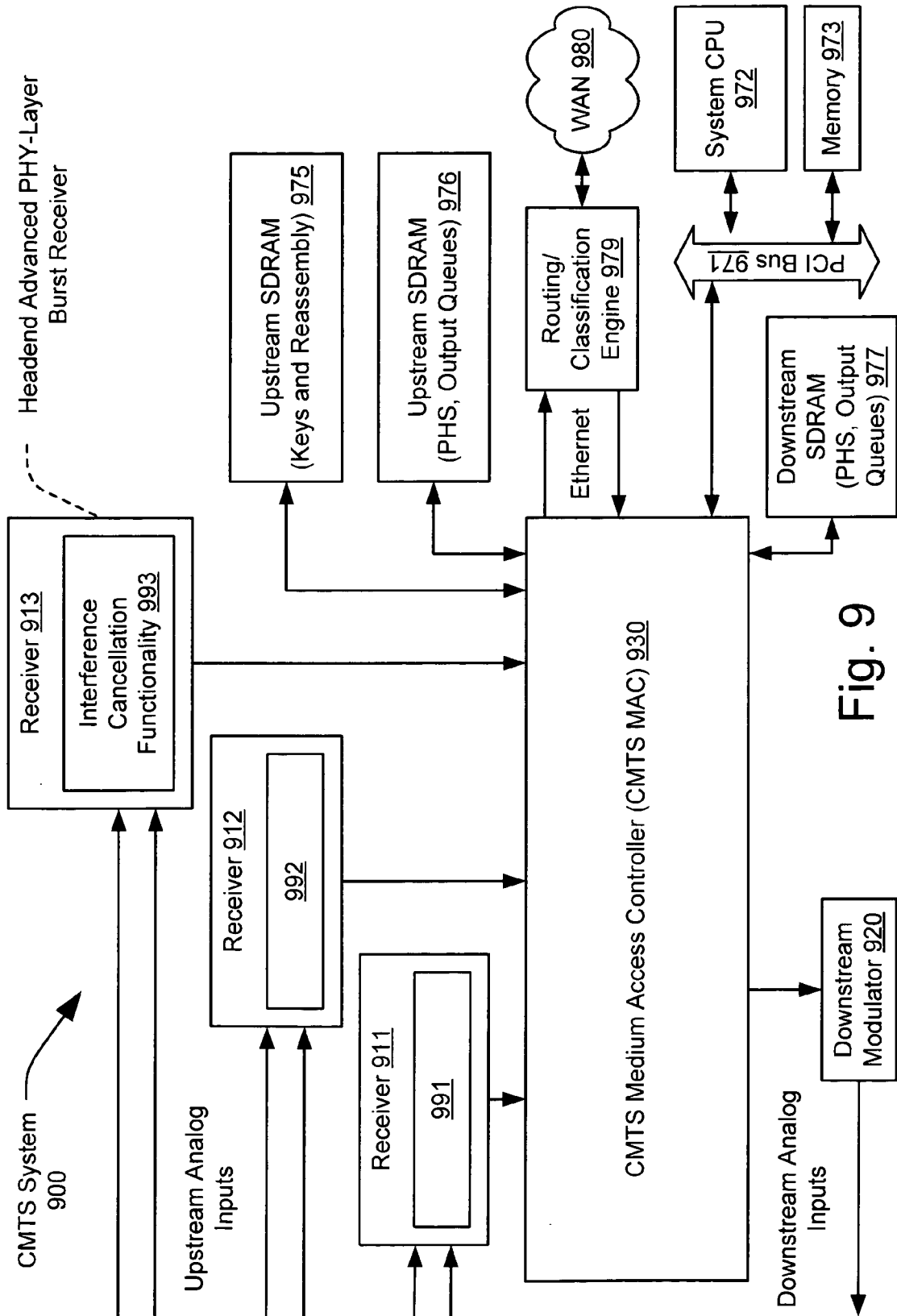

Fig. 9

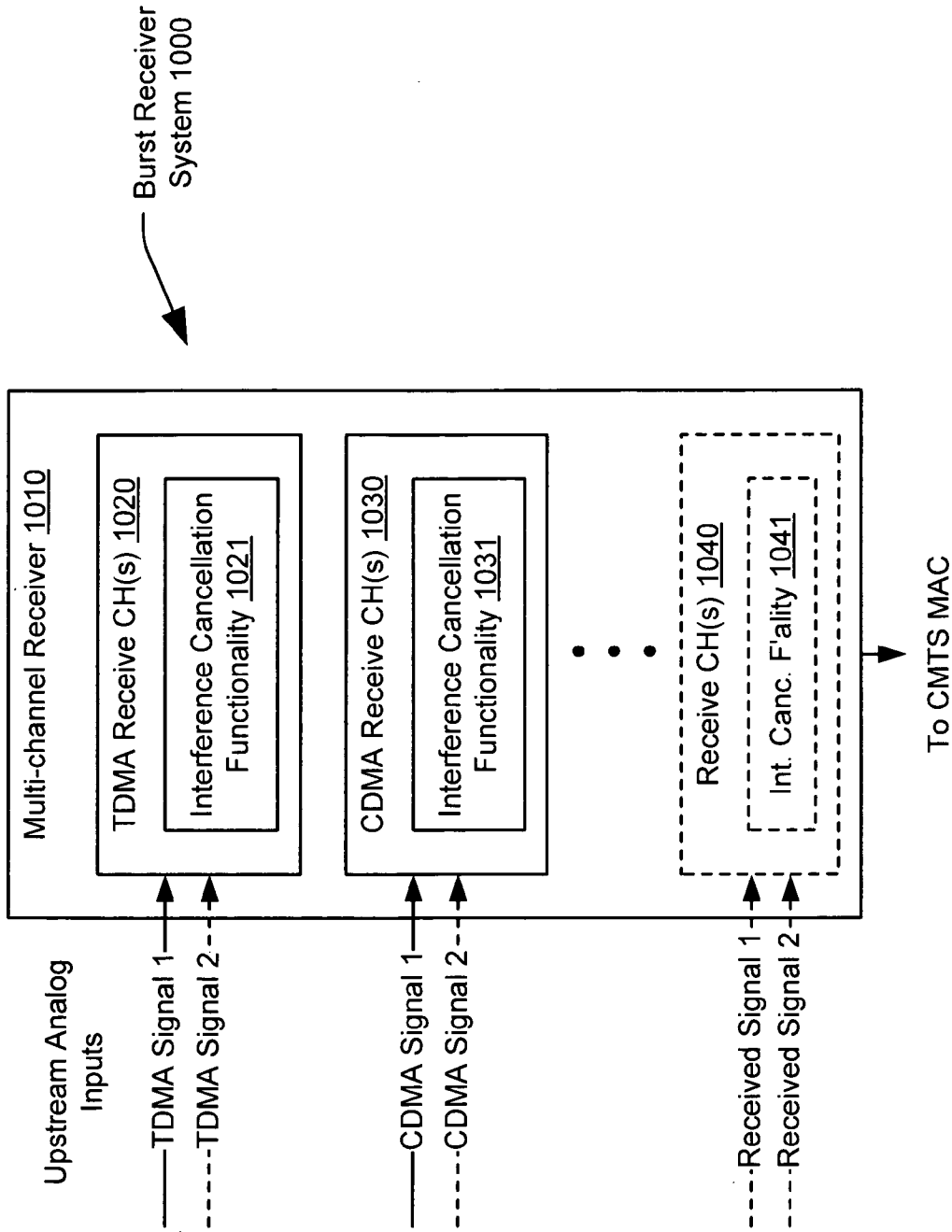

Fig. 10

Single Chip DOCSIS/
EuroDOCSIS CM System 1100

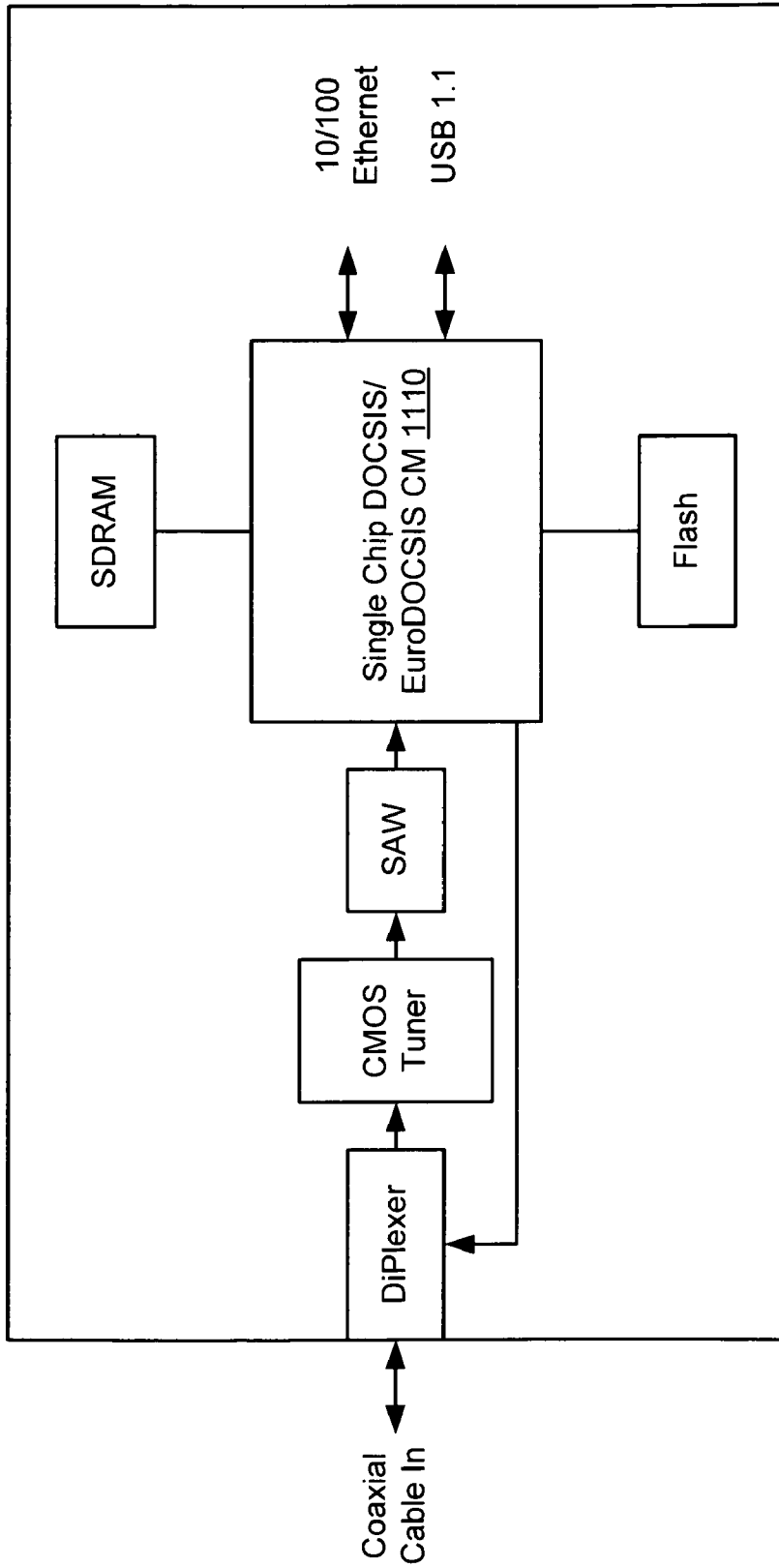

Fig. 11

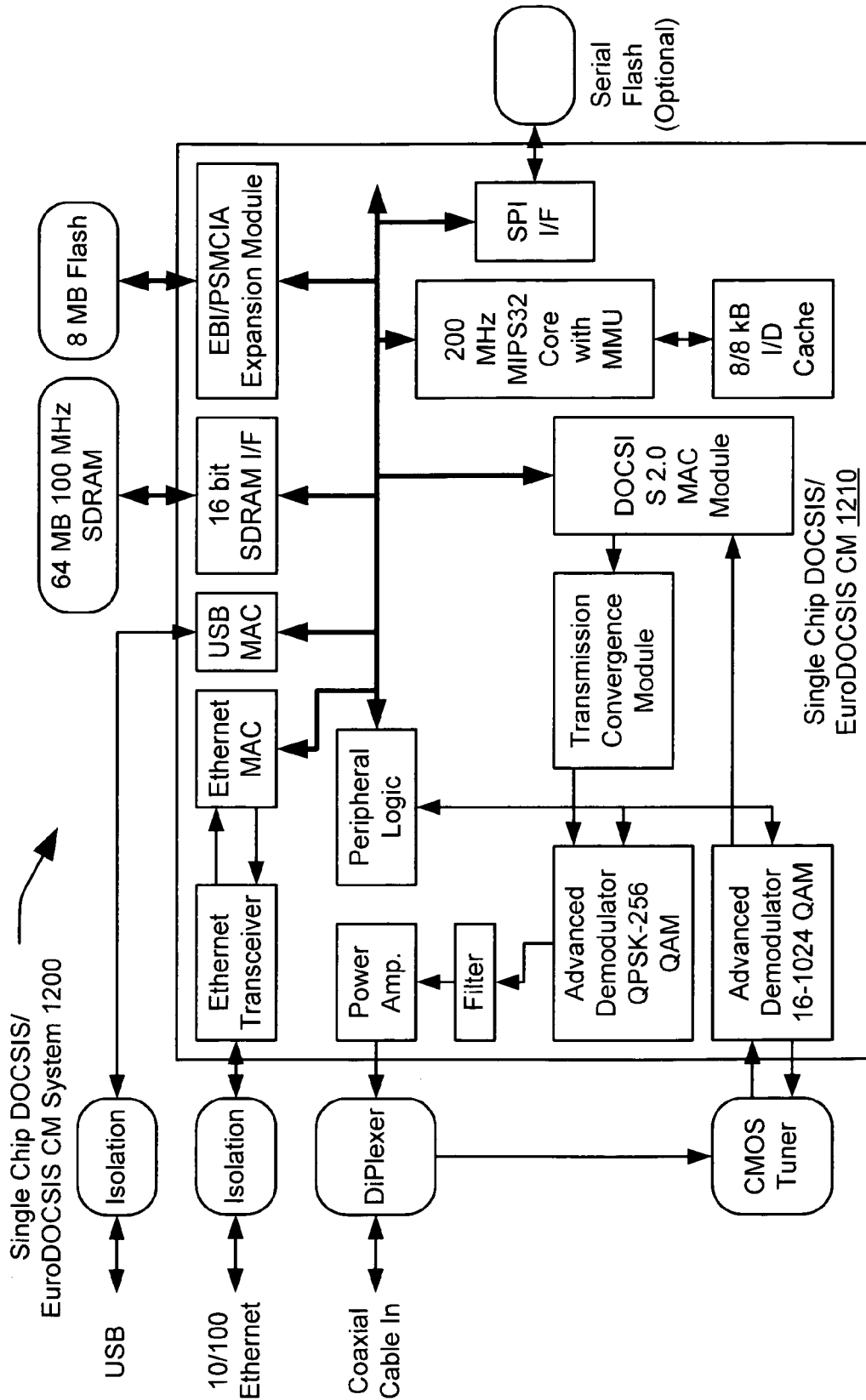

Fig. 12

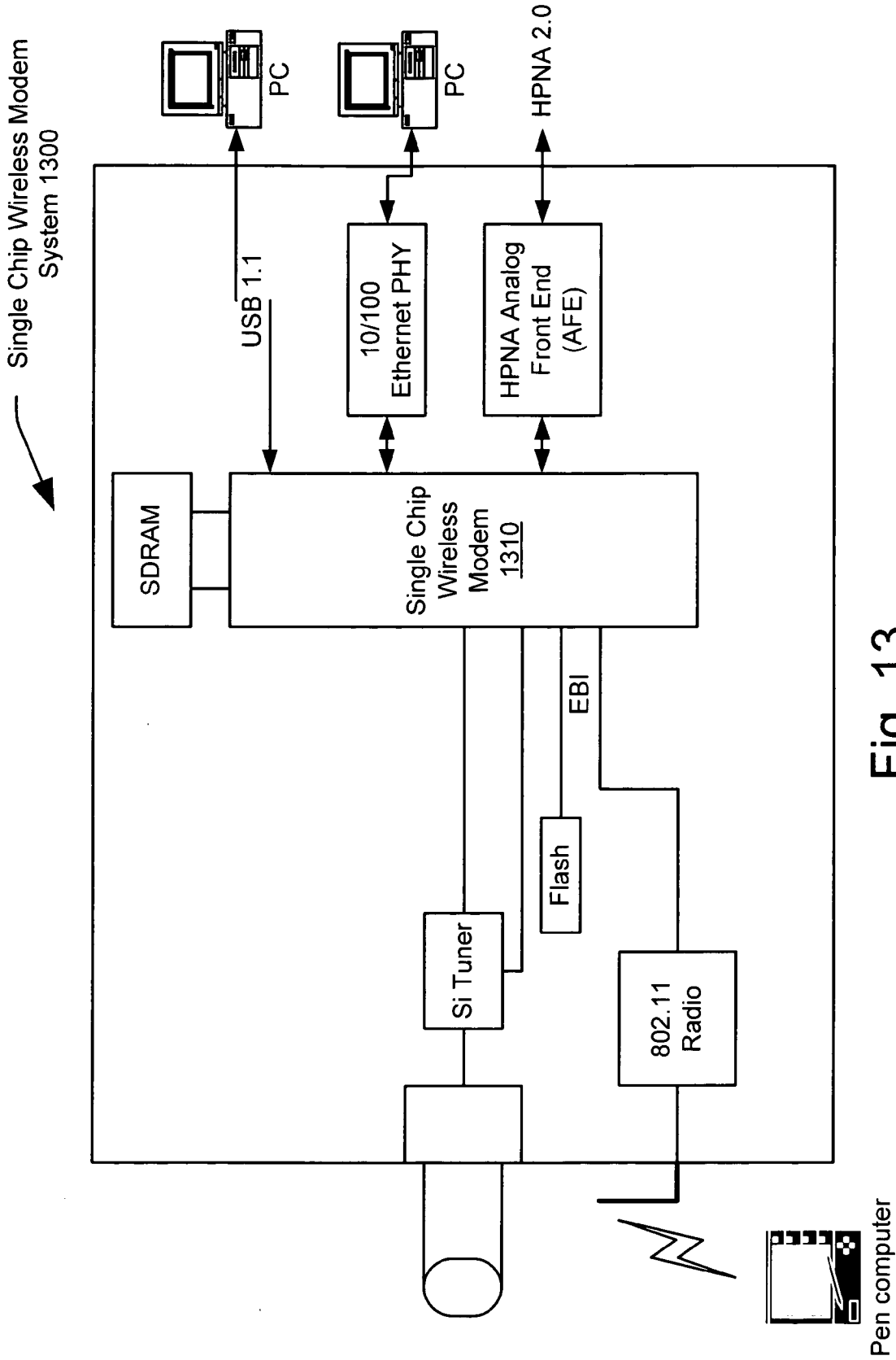

Fig. 13

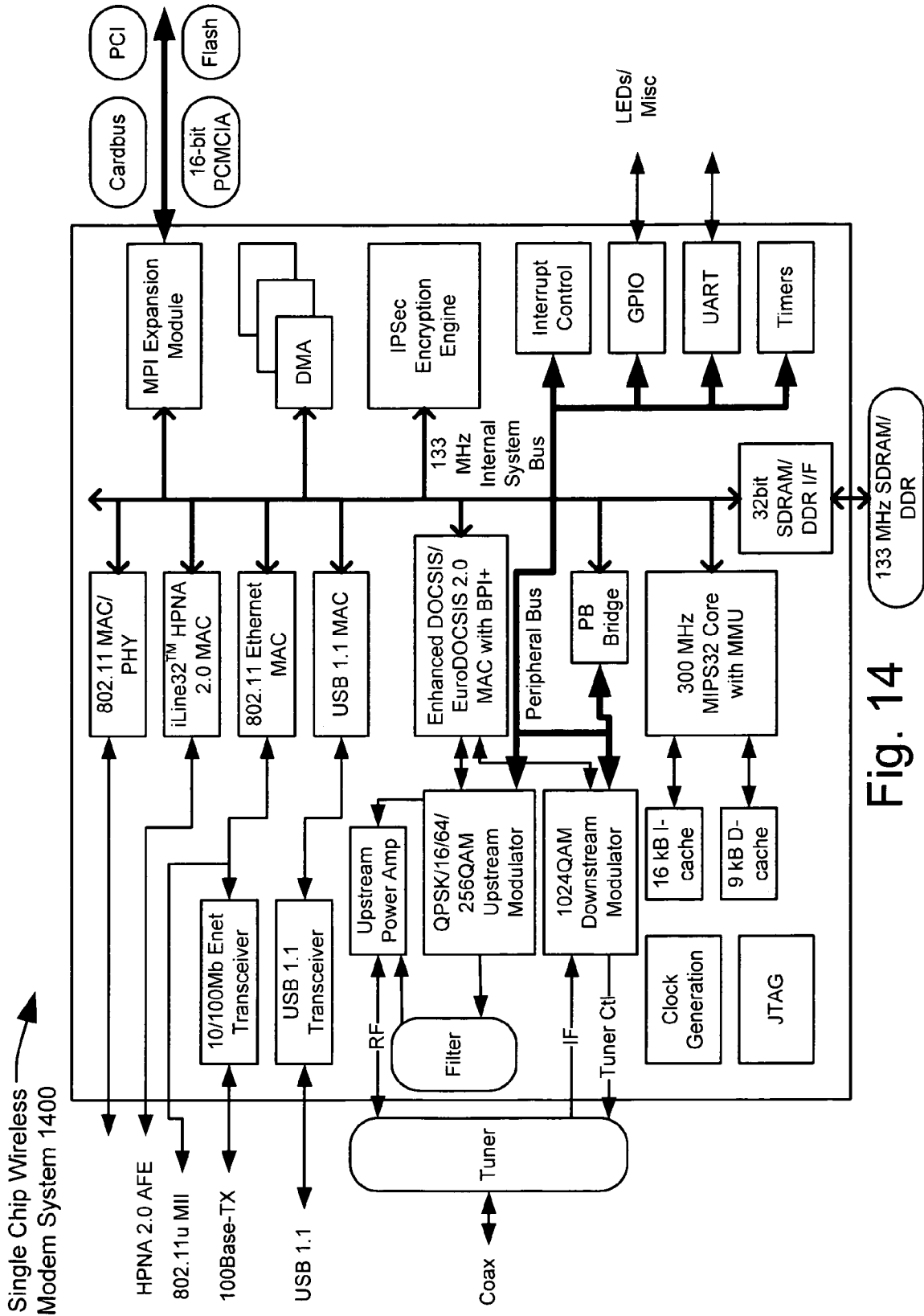

Fig. 14

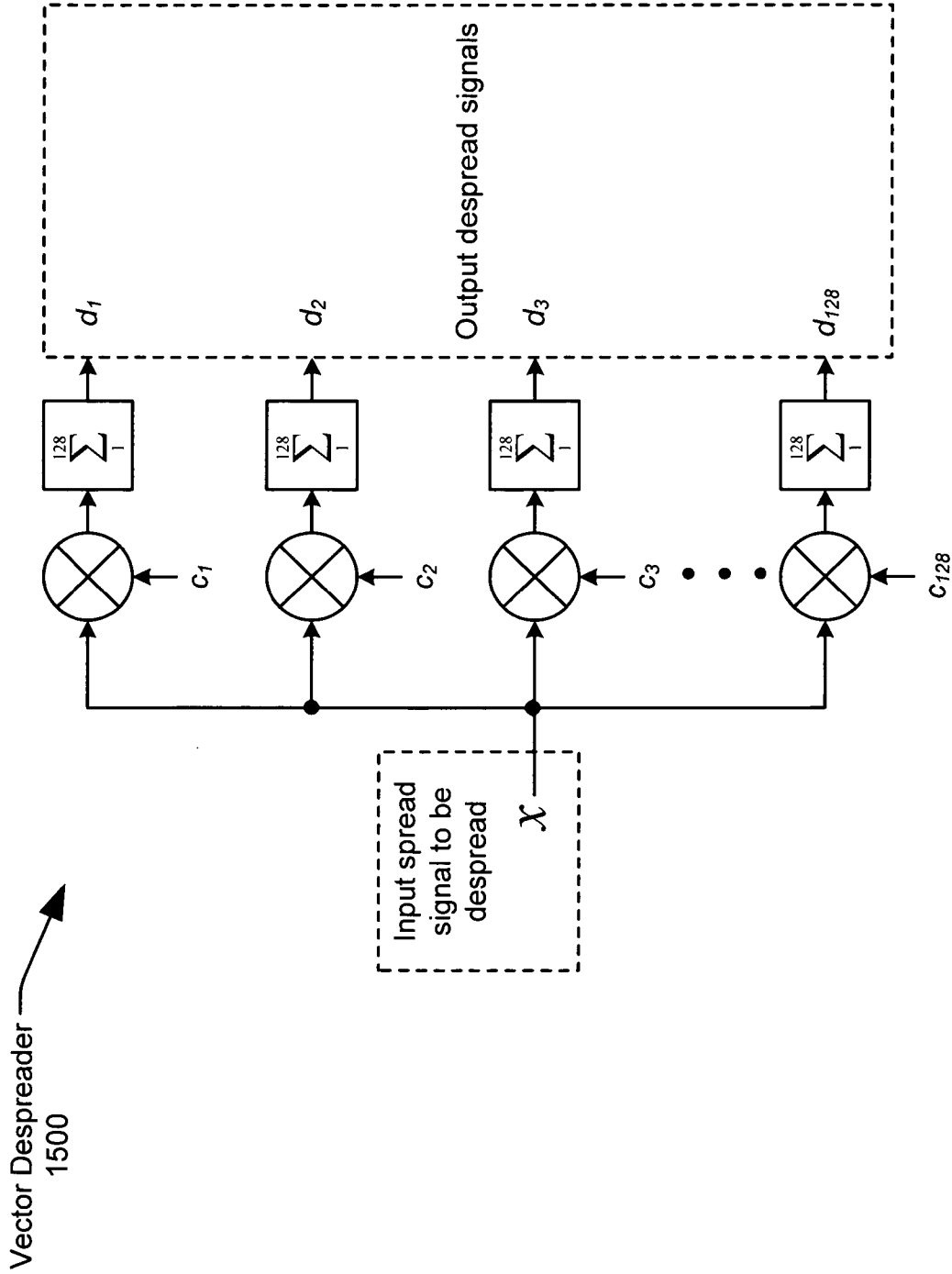

Fig. 15

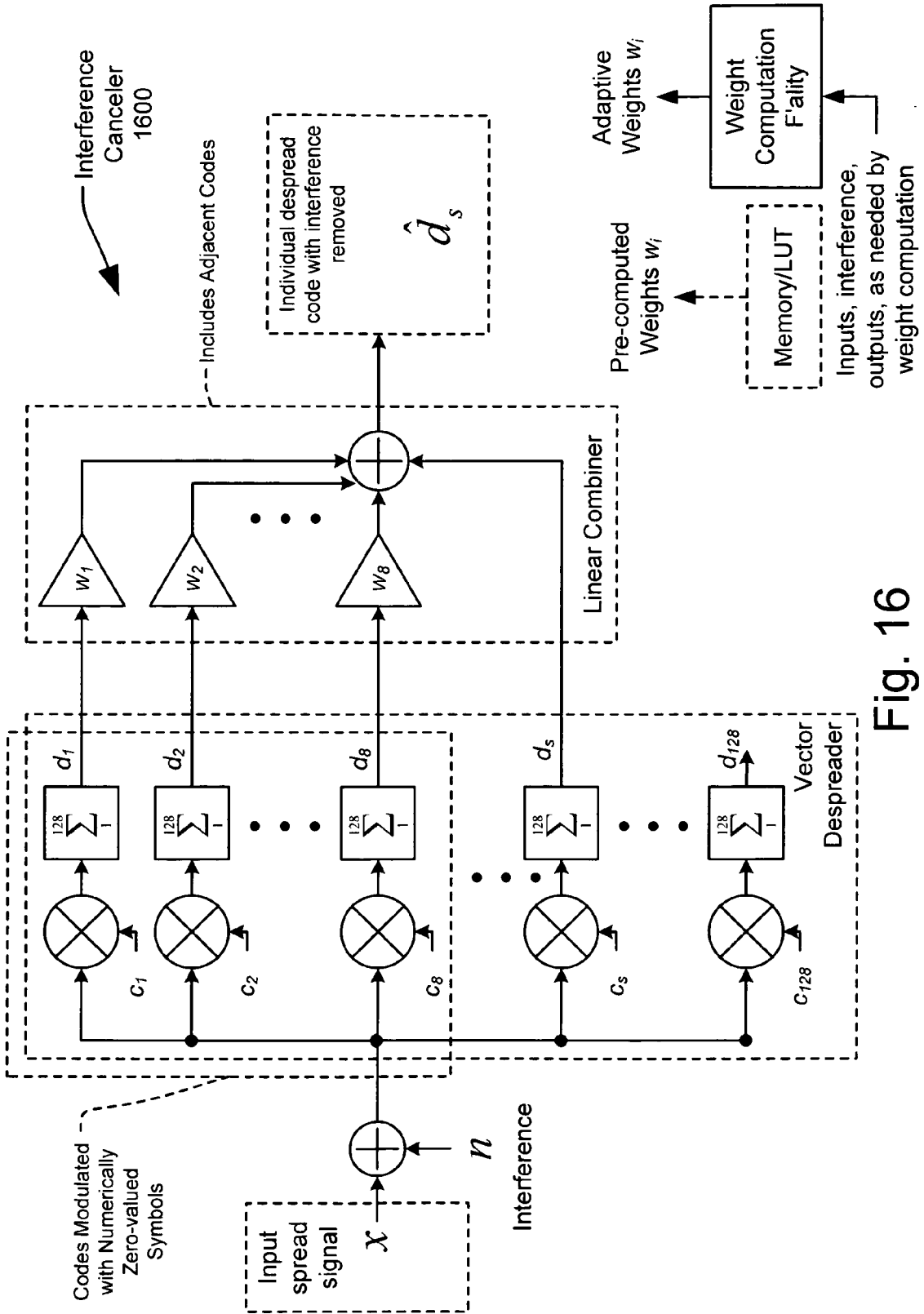

Fig. 16

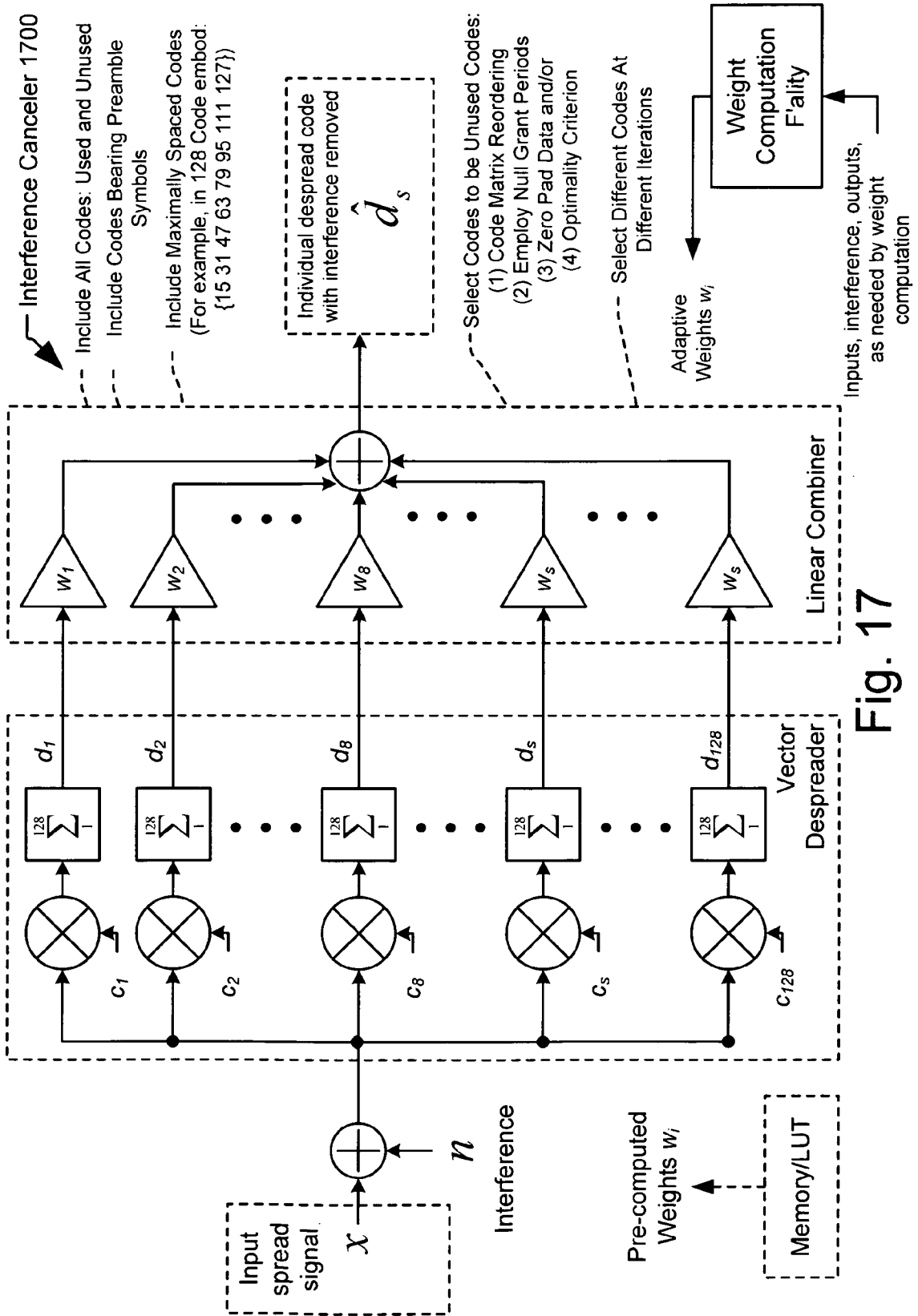

Fig. 17

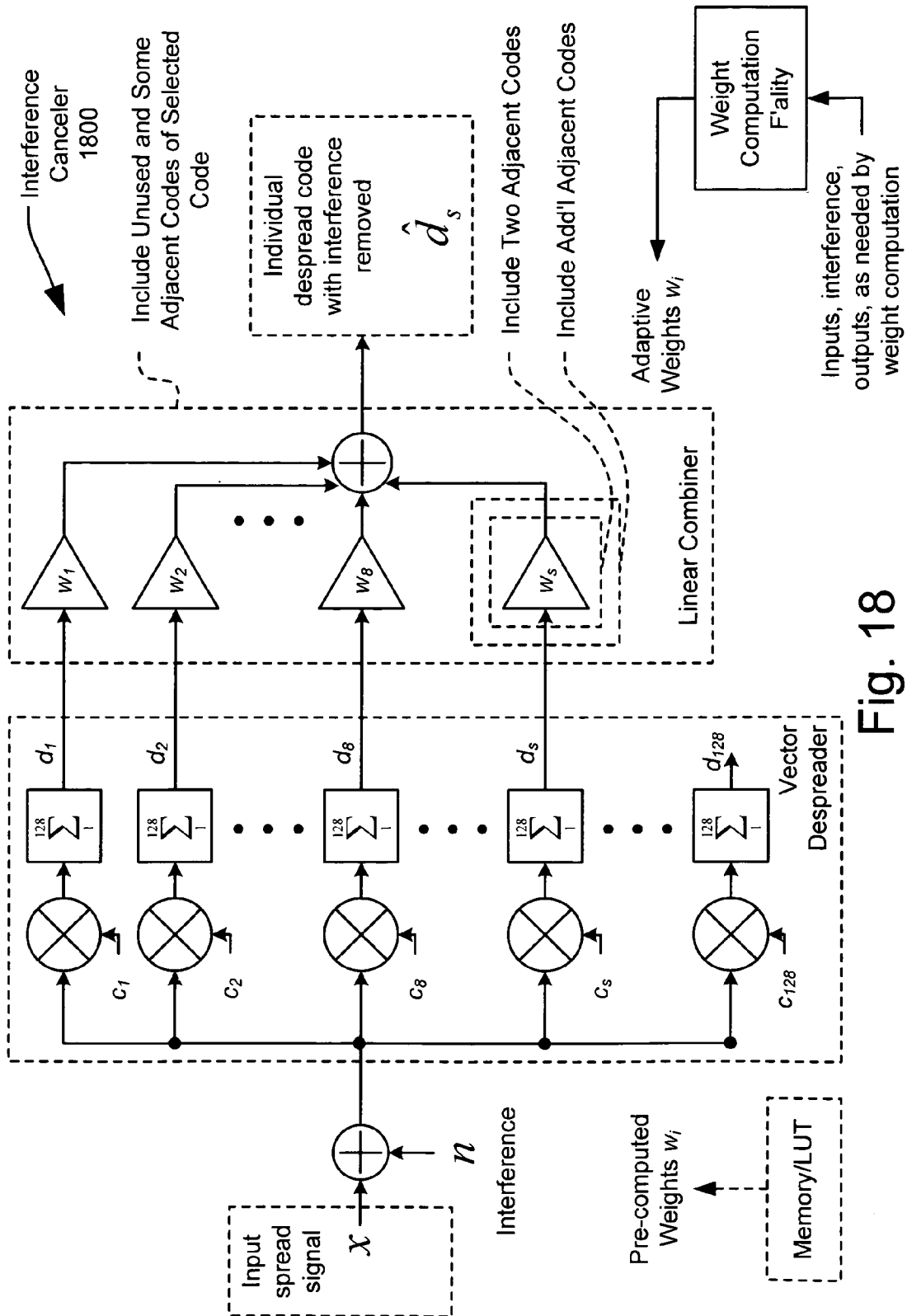

Fig. 18

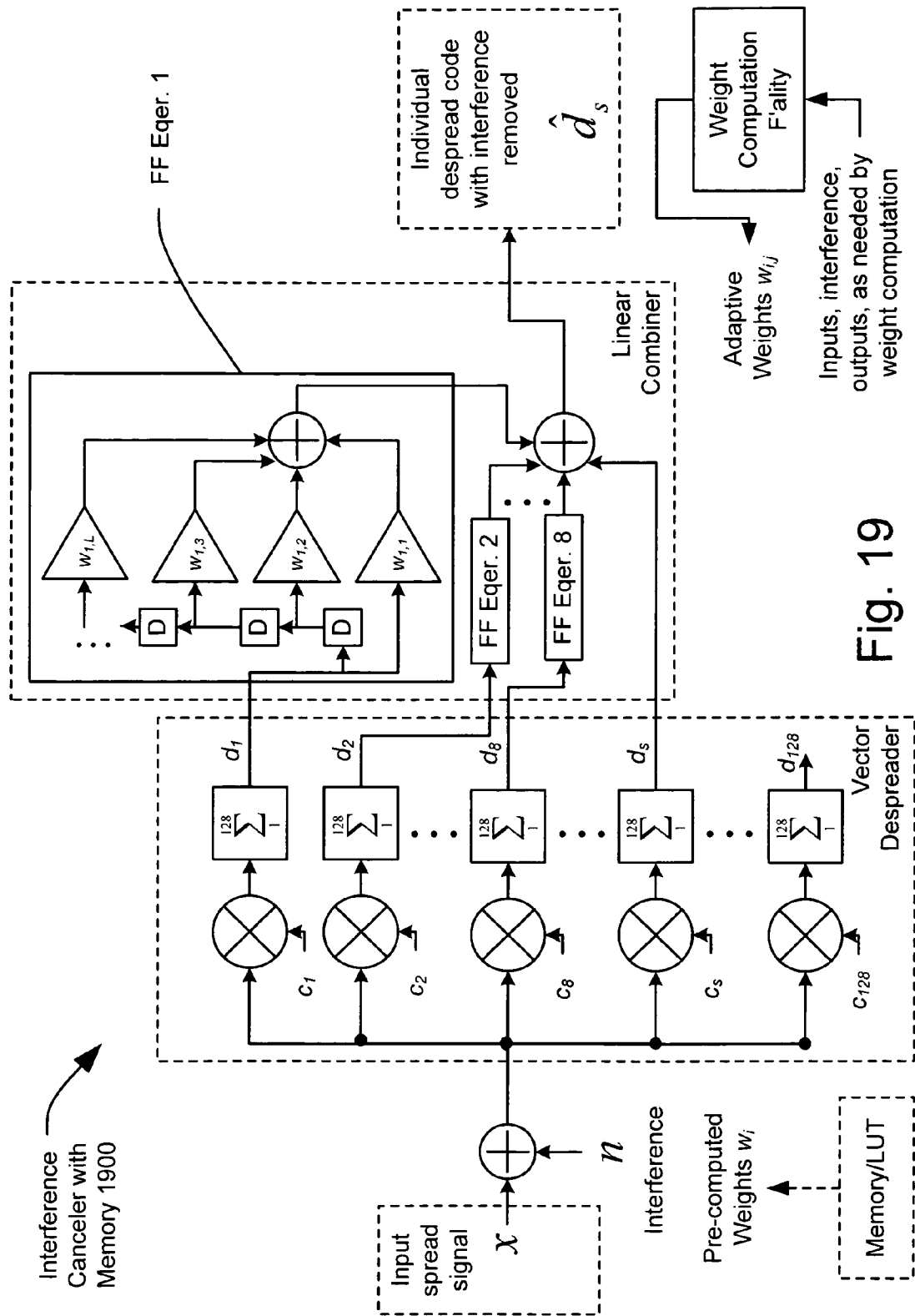

Fig. 19

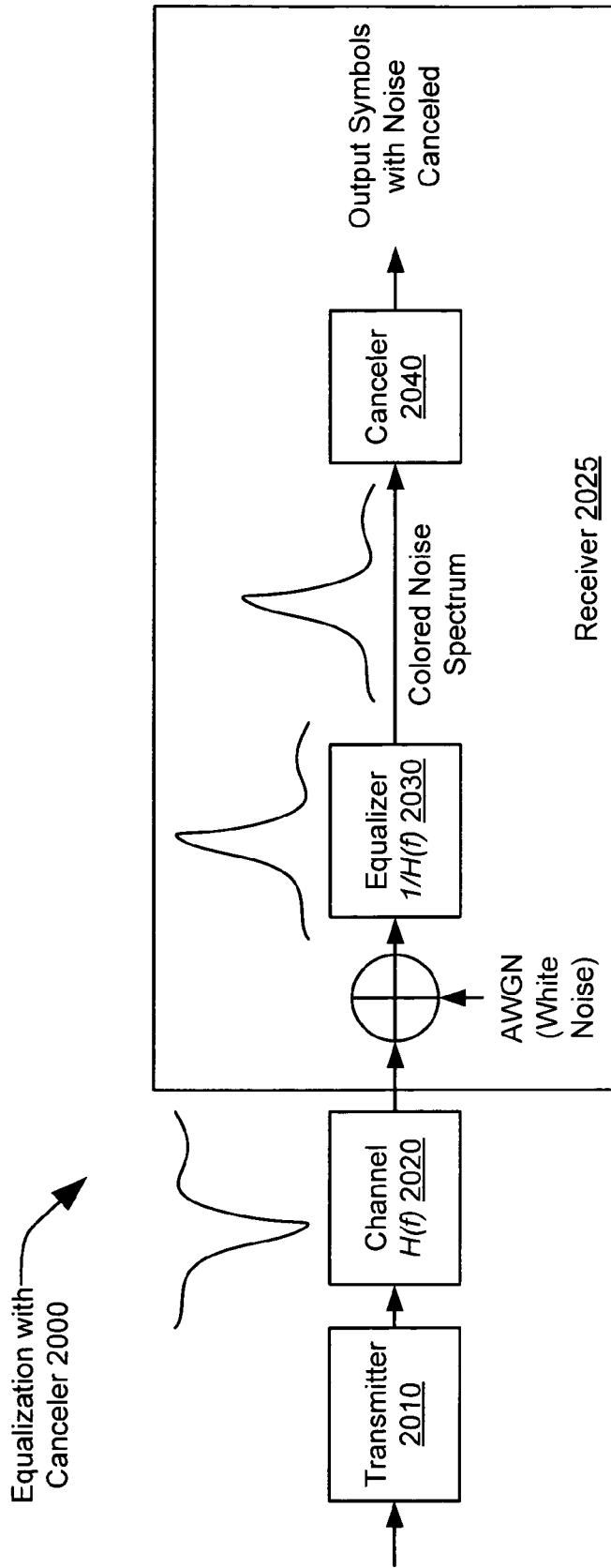

Fig. 20

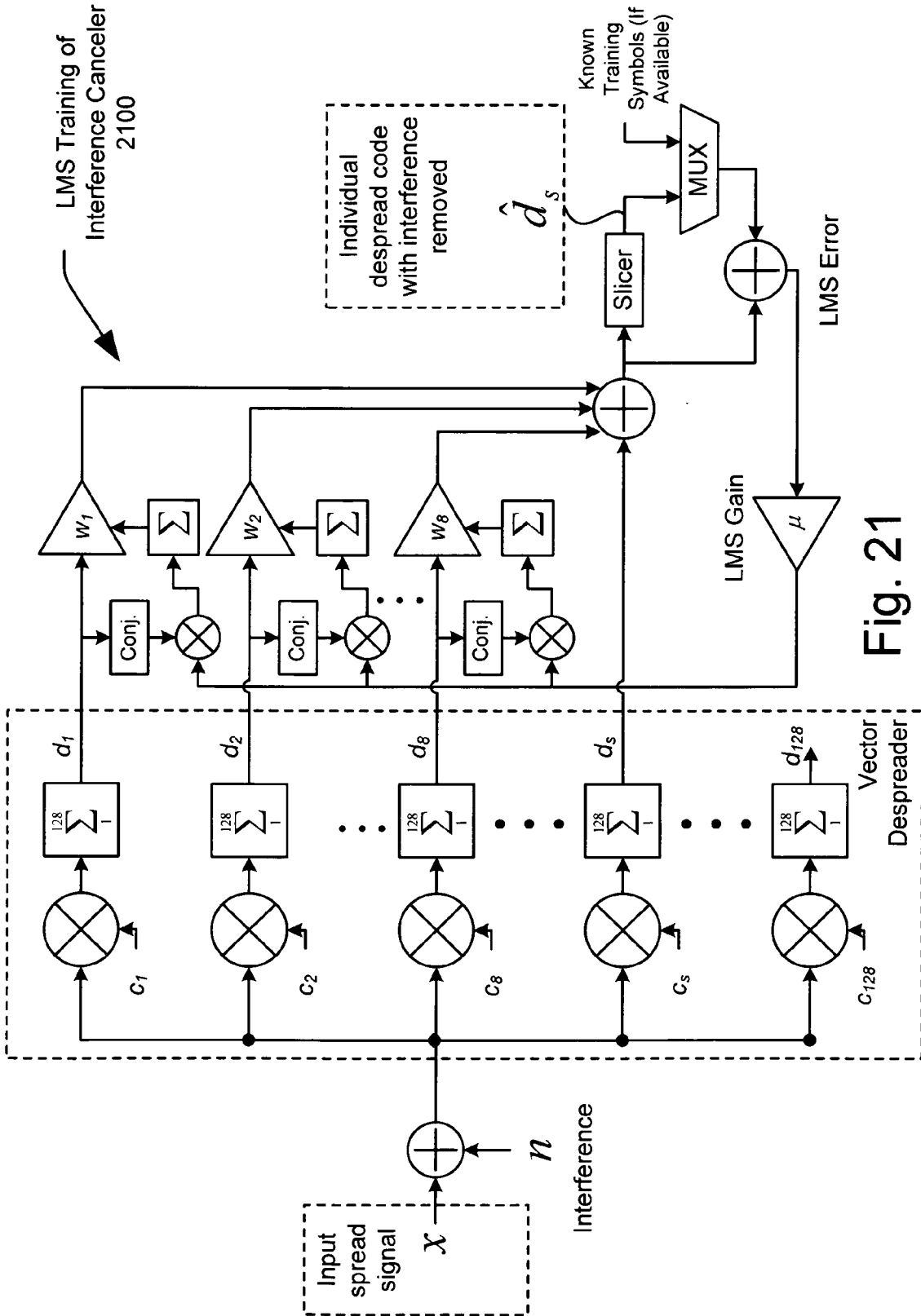
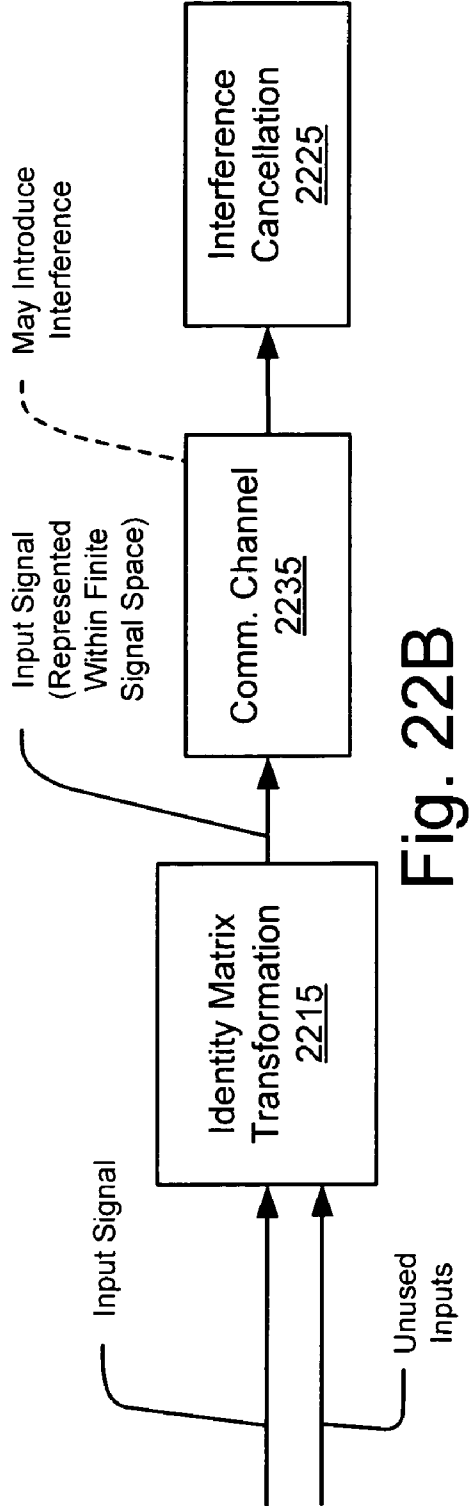
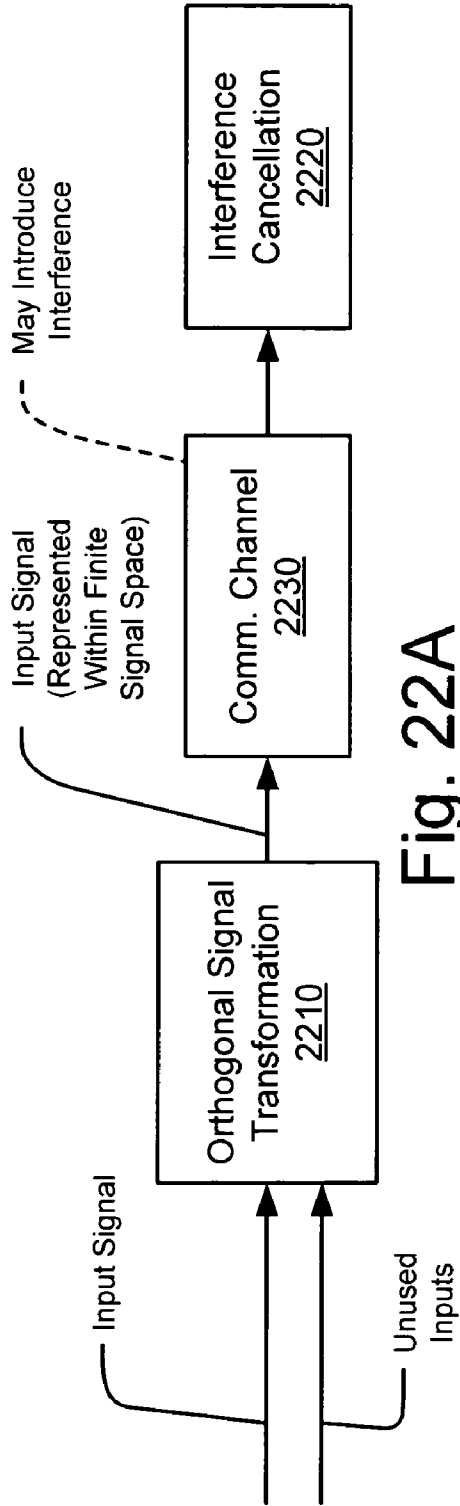

Fig. 21



Interference Cancellation
Method 2300

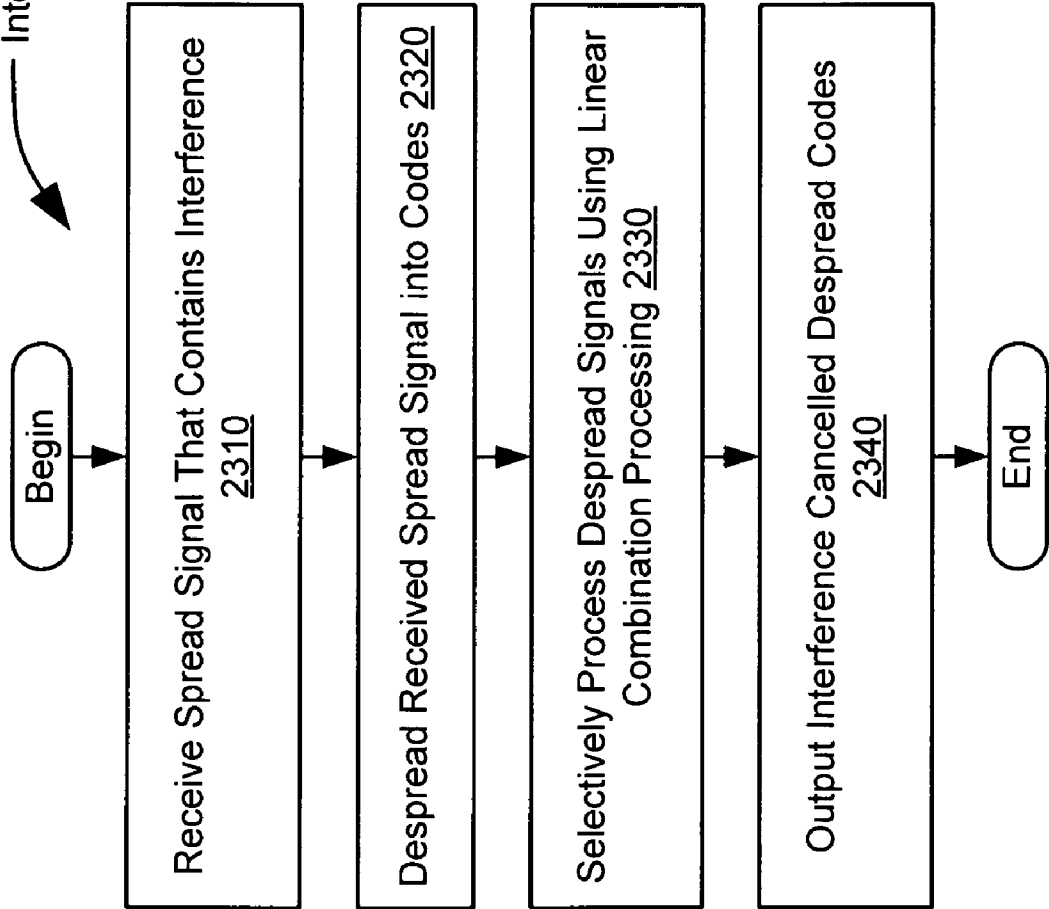

Fig. 23

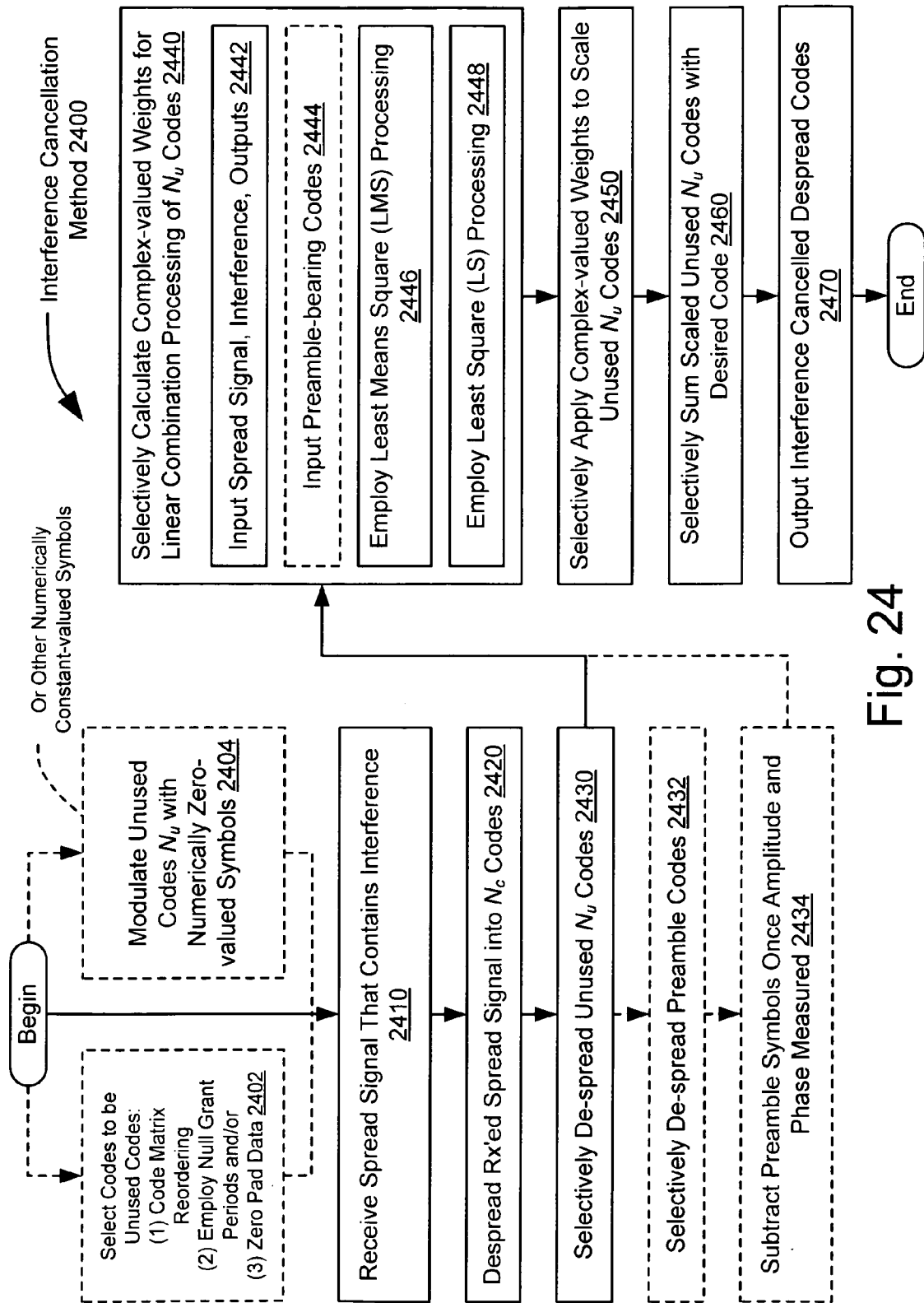

Fig. 24

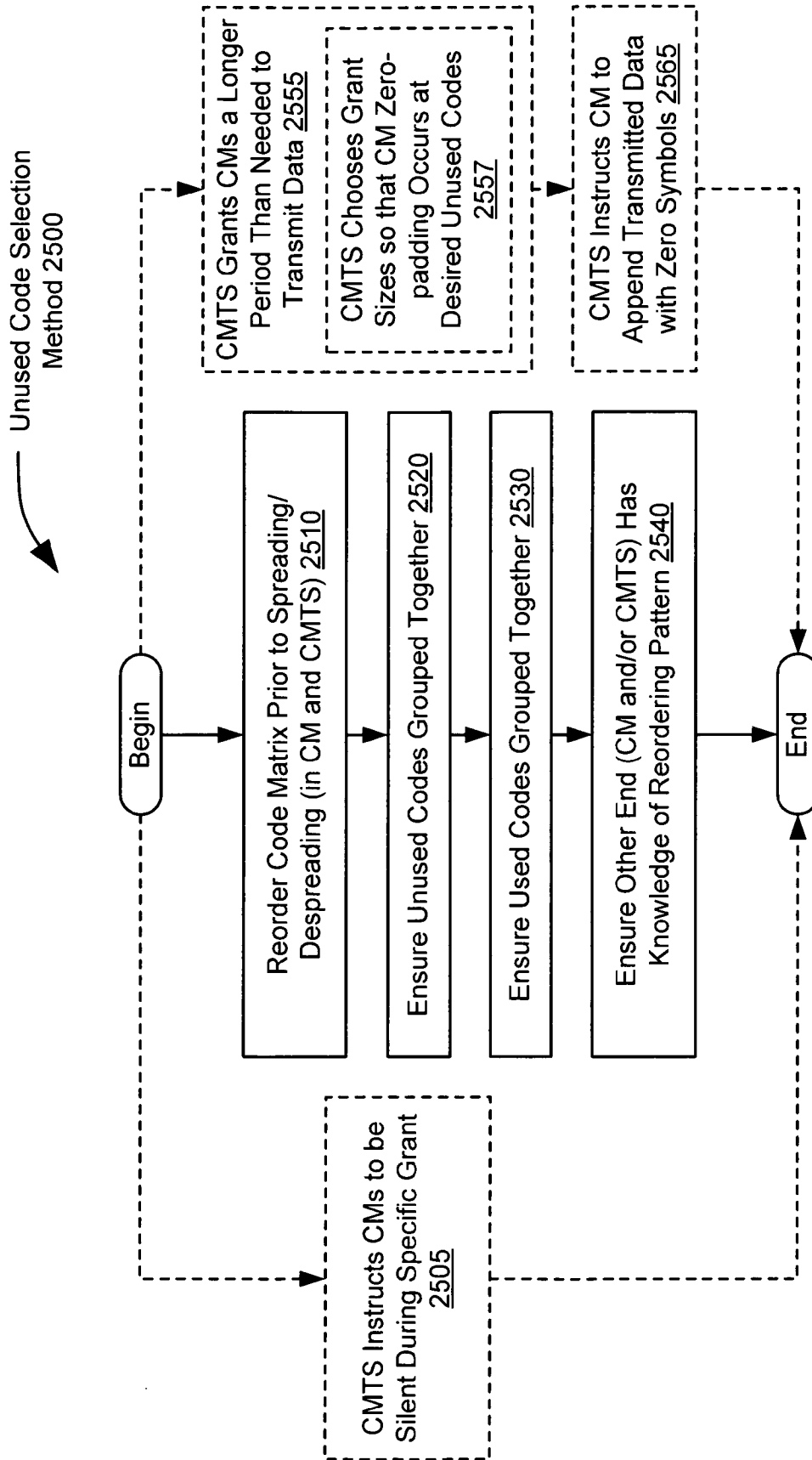

Fig. 25

S-CDMA Interference Cancellation Method 2600

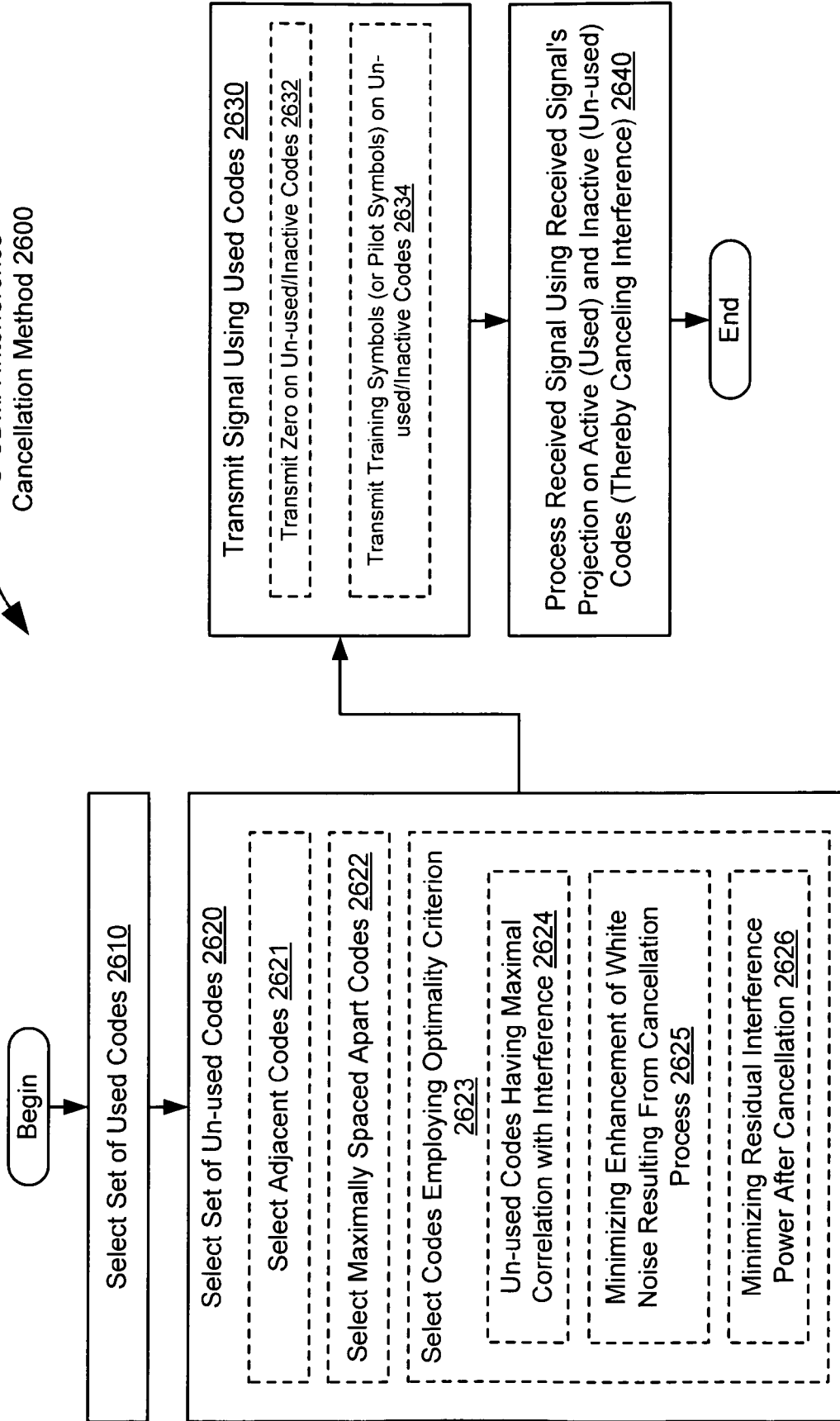

Fig. 26

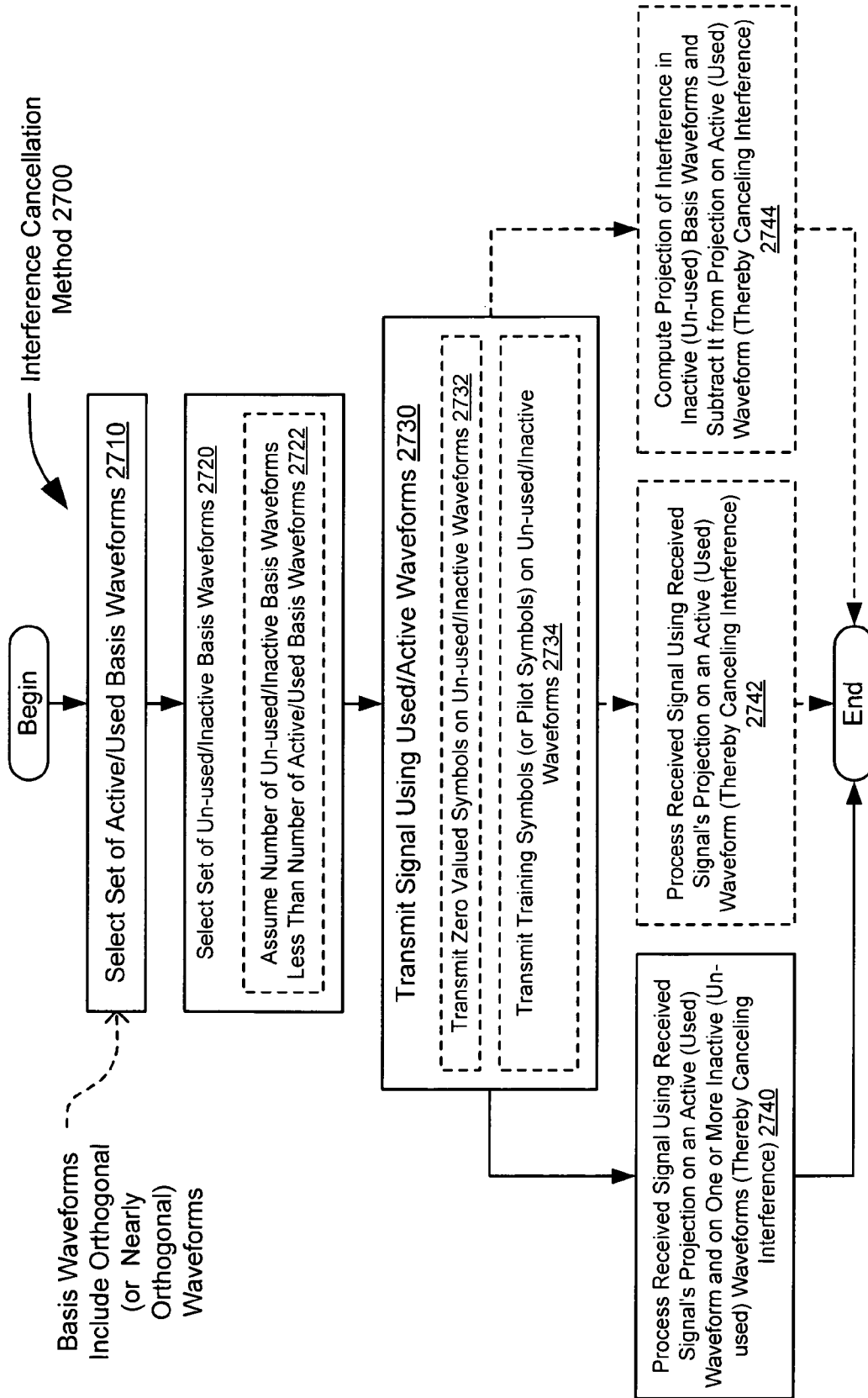
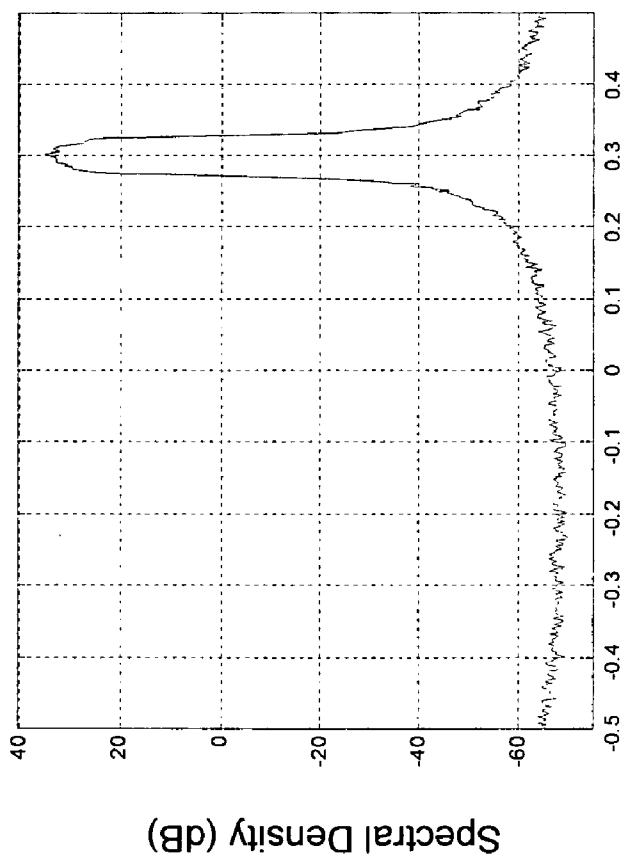

Fig. 27

Spectrum of Narrowband Interference 2800



Frequency

Fig. 28

Spectrum of Adapted
Code Showing Null at
Location of Interference
2900

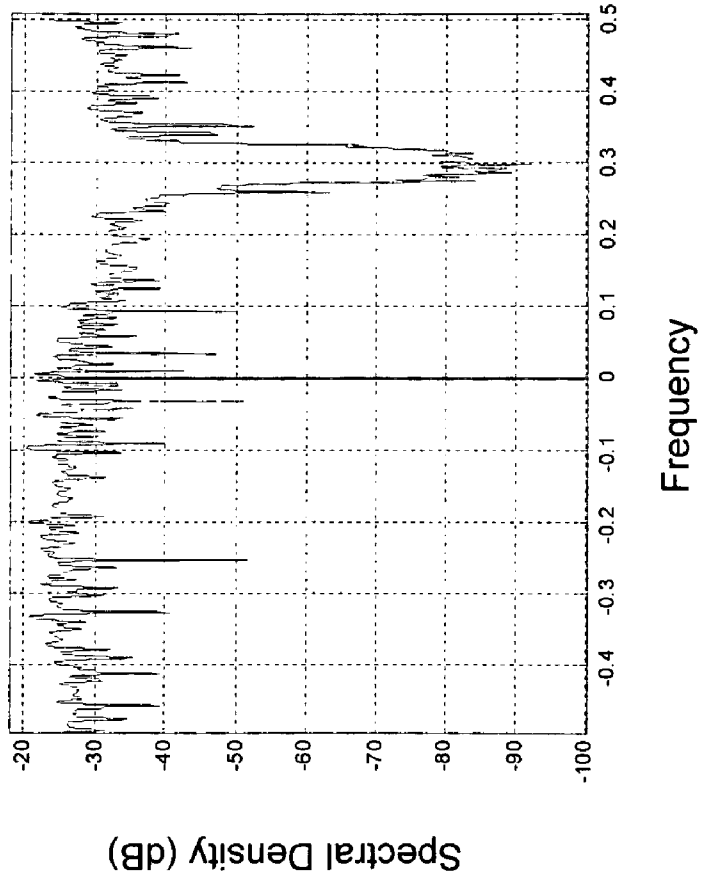
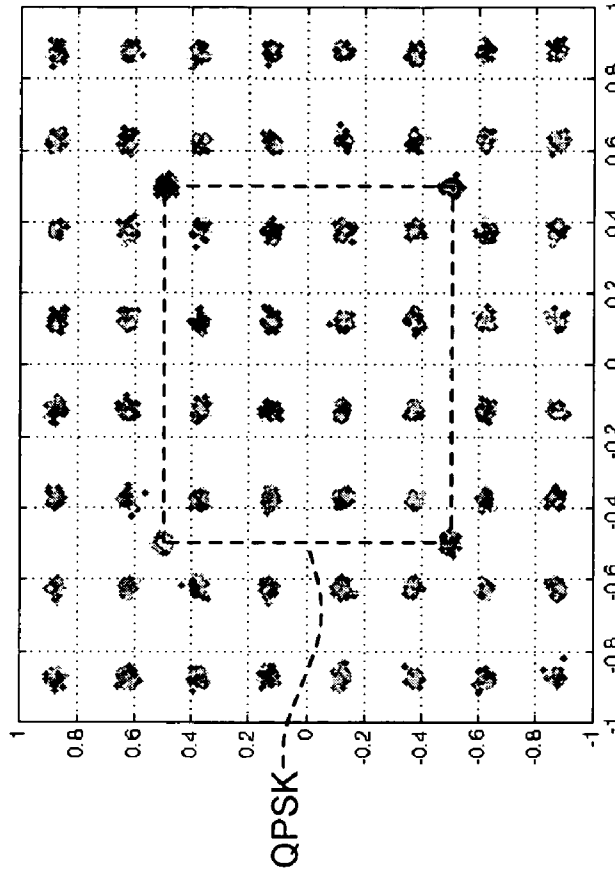

Fig. 29

Received Constellation
After Interference
Cancelled 3005



Received Constellation
Before Interference
Cancelled 3000

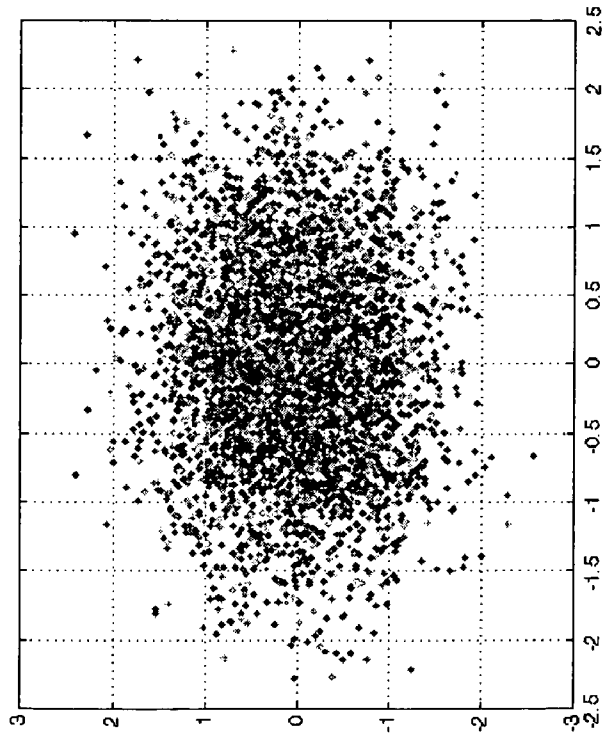

Fig. 30A

Fig. 30B

CANCELLATION OF INTERFERENCE IN A COMMUNICATION SYSTEM WITH APPLICATION TO S-CDMA

CROSS REFERENCE TO RELATED PATENTS/PATENT APPLICATIONS

Continuation Priority Claim, 35 U.S.C. § 120

[0001] The present U.S. Utility Patent Application claims priority pursuant to 35 U.S.C. § 120, as a continuation, to the following U.S. Utility Patent Application which is hereby incorporated herein by reference in its entirety and made part of the present U.S. Utility Patent Application for all purposes:

[0002] 1. U.S. Utility application Ser. No. 10/142,189, entitled "Cancellation of interference in a communication system with application to S-CDMA," (Attorney Docket No. BP2285), filed May 8, 2002, pending, which claims priority pursuant to 35 U.S.C. § 119(e) to the following U.S. Provisional Patent Application which is hereby incorporated herein by reference in its entirety and made part of the present U.S. Utility Patent Application for all purposes:

[0003] 1. U.S. Provisional Application Ser. No. 60/367,564, entitled "Cancellation of interference in a communication system with application to S-CDMA," (Attorney Docket No. BP2285), filed Mar. 26, 2002.

Parent's Continuation-in-Part (CIP) Priority Claim, 35 U.S.C. § 120

[0004] The U.S. Utility application Ser. No. 10/142,189, from which the present U.S. Utility Patent Application is a continuation, also claims priority pursuant to 35 U.S.C. § 120, as a continuation-in-part (CIP), to the following U.S. Utility Patent Application which is hereby incorporated herein by reference in its entirety and made part of the present U.S. Utility Patent Application for all purposes:

[0005] 1. U.S. Utility application Ser. No. 09/652,721, entitled "Subdimensional single carrier modulation," (Attorney Docket No. BP 1140), filed Aug. 31, 2000, now U.S. Pat. No. 6,778,611 B1, issued on Aug. 17, 2004, which claims priority pursuant to 35 U.S.C. § 119(e) to the following U.S. Provisional Patent Application which is hereby incorporated herein by reference in its entirety and made part of the present U.S. Utility Patent Application for all purposes:

[0006] 1. U.S. Provisional Application Ser. No. 60/151,680, entitled "Subdimensional single carrier modulation," (Attorney Docket No. BP2285), filed Aug. 31, 1999.

BACKGROUND OF THE INVENTION

[0007] 1. Technical Field of the Invention

[0008] The invention relates generally to communication systems; and, more particularly, it relates to communication systems that may be affected by undesirable interference.

[0009] 2. Description of Related Art

[0010] Signal processing within communication systems having a communication channel, in an effort to improve the quality of signals passing through the communication channel, has been under development for many years. In the past several years, emphasis has moved largely to the domain of digital communication systems that modulate bit streams into an analog signal for transmission over a communication channel. This channel can be a variety of channel types. Many different approaches are employed in the prior art to try to

minimize or substantially reduce the effects of interference that may be introduced into a signal that is transmitted across a communication channel. In particular, the prior art approaches that seek to perform cancellation of interference that occupies a small number of signal dimensions in a signal are typically deficient for a number of reasons as is briefly referenced below. One particular type of interference that these prior art schemes seek to minimize is the narrowband interference that is sometimes referred to as ingress interference. Another type of narrowband interference that may be problematic is the interference of impulse/burst noise. Yet another type of interference that may be problematic is within the code division multiple access (CDMA) context when the interference is on a small number of codes.

[0011] One of the main methods employed in the prior art to eliminate this interference is the use of a notch filter. This solution is sufficient in some applications, but the notch filter itself oftentimes causes distortion of the desired signal. In the CDMA context, this distortion is called inter-code interference (ICI). Then, another means must oftentimes be included to remove the very ICI that has been introduced by the notch filter. One way to do this is to de-spread the signal. Then, hard decisions are made using the de-spread signal. The hard decisions are then respread and passed through the notch filter and to subtract from the original signal to remove the estimated distortion. In some instances, this process is repeated numerous times to try to achieve an adequate result.

[0012] These prior art approaches described above are deficient in that they suffer the effect of the error propagation. The decision circuit is prone to make incorrect decisions, requiring many iterations before the process converges, if it ever converges at all.

[0013] Further limitations and disadvantages of conventional and traditional systems will become apparent through comparison of such systems with the invention as set forth in the remainder of the present application with reference to the drawings.

BRIEF SUMMARY OF THE INVENTION

[0014] Various aspects of the invention can be found in a communication receiver that supports interference cancellation functionality. The present invention uses a linear combination of the unused dimensions (for example, the unused codes) to cancel the interference. This may be done after the de-spreader, or, equivalently, as part of the de-spreading process. There is no appreciable inter-code interference introduced and no decision errors are made as part of this process. The allocation of unused codes reduces the capacity of the system by a small amount. In one embodiment, the reduction of capacity of the system will be to 120/128 of the original capacity for a system of 128 codes where 8 unused codes are employed. Clearly, other numbers of available codes may also be employed without departing from the scope and spirit of the invention.

[0015] It is noted that the present invention may be extended across a wide variety of application contexts. The present technique can be applied to cancel not only narrowband interference, but any interference that occupies a small number of dimensions in the signal space. The narrowband interference includes just one of the many types of interferences that may be substantially cancelled according to the present invention. A narrowband signal occupies a small number of DFT (discrete Fourier transform) bins, showing that it occupies a small number of dimensions in signal space.

An extremely simple example is a CW (Continuous Wave) signal whose frequency is an integer multiple of the de-spread symbol rate; this CW signal occupies only a single bin in the DFT, or only one dimension in the signal space, where each dimension is, in this case, one DFT bin. Another example is a short burst of noise (impulse or burst noise). A short burst signal occupies a small number of time samples, again showing that it too occupies a small number of dimensions, where each dimension is, in this case, a time sample.

[0016] Other types of signals may be constructed, without limit, that satisfy the property that they occupy a small number of dimensions in their respective signal space. All such signals can be canceled by the present technique. It is noted that the DFT is just one example of an orthonormal expansion. A second example is the code matrix in DOCSIS 2.0 S-CDMA. A third example may be the identity matrix. Innumerable other orthonormal transforms also exist that are used to transform a signal into a finite signal space. If a signal occupies a small number of dimensions in any orthonormal transformation, the interference cancellation performed according to the present invention may be used for canceling it. It is noted here that orthogonal transformations may also be used without departing from the scope and spirit of the invention in any way within embodiments where normalization of not of concern or of low priority.

[0017] A number of specific embodiments are illustrated to show the versatility and wide applicability of the present invention across a variety of communication systems contexts. However, it is generally noted that the present invention may be practiced within any communication system that seeks to perform interference cancellation when the communication system employs signaling that occupies a small number of dimensions in the communication signal's space.

[0018] The present invention is directed to apparatus and methods of operation that are further described in the following Brief Description of the Several Views of the Drawings, the Detailed Description of the Invention, and the claims. Other features and advantages of the present invention will become apparent from the following detailed description of the invention made with reference to the accompanying drawings.

BRIEF DESCRIPTION OF THE SEVERAL VIEWS OF THE DRAWINGS

[0019] A better understanding of the invention can be obtained when the following detailed description of various exemplary embodiments is considered in conjunction with the following drawings.

[0020] FIG. 1 is a system diagram illustrating an embodiment of a cable modem (CM) communication system that is built according to the present invention.

[0021] FIG. 2 is a system diagram illustrating another embodiment of a CM communication system that is built according to the present invention.

[0022] FIG. 3A is a system diagram illustrating an embodiment of a cellular communication system that is built according to the present invention.

[0023] FIG. 3B is a system diagram illustrating another embodiment of a cellular communication system that is built according to the present invention.

[0024] FIG. 4 is a system diagram illustrating an embodiment of a satellite communication system that is built according to the present invention.

[0025] FIG. 5A is a system diagram illustrating an embodiment of a microwave communication system that is built according to the present invention.

[0026] FIG. 5B is a system diagram illustrating an embodiment of a point-to-point radio communication system that is built according to the present invention.

[0027] FIG. 6 is a system diagram illustrating an embodiment of a high definition (HDTV) communication system that is built according to the present invention.

[0028] FIG. 7 is a system diagram illustrating an embodiment of a communication system that is built according to the present invention.

[0029] FIG. 8 is a system diagram illustrating another embodiment of a communication system that is built according to the present invention.

[0030] FIG. 9 is a system diagram illustrating an embodiment of a cable modem termination system (CMTS) system that is built according to the present invention.

[0031] FIG. 10 is a system diagram illustrating an embodiment of a burst receiver system that is built according to the present invention.

[0032] FIG. 11 is a system diagram illustrating an embodiment of a single chip DOCSIS/EuroDOCSIS CM system that is built according to the present invention.

[0033] FIG. 12 is a system diagram illustrating another embodiment of a single chip DOCSIS/EuroDOCSIS CM system that is built according to the present invention.

[0034] FIG. 13 is a system diagram illustrating an embodiment of a single chip wireless modem system that is built according to the present invention.

[0035] FIG. 14 is a system diagram illustrating another embodiment of a single chip wireless modem system that is built according to the present invention.

[0036] FIG. 15 is a diagram illustrating an embodiment of a vector de-spreader that is built according to the present invention.

[0037] FIG. 16 is a diagram illustrating an embodiment of an interference canceller that is built according to the present invention.

[0038] FIG. 17 is a diagram illustrating another embodiment of an interference canceller that is built according to the present invention.

[0039] FIG. 18 is a diagram illustrating another embodiment of an interference canceller that is built according to the present invention.

[0040] FIG. 19 is a diagram illustrating an embodiment of an interference canceller with memory that is built according to the present invention.

[0041] FIG. 20 is a diagram illustrating an embodiment of equalization with canceller that is arranged according to the present invention.

[0042] FIG. 21 is a diagram illustrating an embodiment of Least Means Square (LMS) training of an interference canceller according to the present invention.

[0043] FIG. 22A is a diagram illustrating an embodiment of signal transformation according to the present invention.

[0044] FIG. 22B is a diagram illustrating another embodiment of signal transformation according to the present invention.

[0045] FIG. 23 is an operational flow diagram illustrating an embodiment of an interference cancellation method that is performed according to the present invention.

[0046] FIG. 24 is an operational flow diagram illustrating another embodiment of an interference cancellation method that is performed according to the present invention.

[0047] FIG. 25 is an operational flow diagram illustrating an embodiment of an unused code selection method that is performed according to the present invention.

[0048] FIG. 26 is an operational flow diagram illustrating an embodiment of an S-CDMA interference cancellation method that is performed according to the present invention.

[0049] FIG. 27 is an operational flow diagram illustrating another embodiment of an interference cancellation method that is performed according to the present invention.

[0050] FIG. 28 is a diagram illustrating an embodiment of a spectrum of narrowband interference that may be addressed and overcome when practicing the present invention.

[0051] FIG. 29 is a diagram illustrating an embodiment of a spectrum of an adapted code showing a null at a location of interference that may be achieved when practicing the present invention.

[0052] FIG. 30A is a diagram illustrating an embodiment of a received constellation before interference has been cancelled when practicing the present invention.

[0053] FIG. 30B is a diagram illustrating an embodiment of a received constellation after interference has been cancelled when practicing the present invention.

DETAILED DESCRIPTION OF THE INVENTION

[0054] The present invention provides a solution for interference cancellation for communication systems (where a medium is used by one user or if shared among many users). More specifically, the present invention is applicable within code-division multiple access (CDMA) communication systems, as well as synchronous code-division multiple access (S-CDMA) communication systems. One particular type of S-CDMA communication system that may benefit from the present invention is the Data Over Cable Service Interface Specifications (DOCSIS) version 2.0 S-CDMA that is operable for communication systems. The present invention presents a solution that provides for cancellation of interference in any such communication systems. The interference cancellation may be viewed as being directed primarily towards the type of interference that occupies a small number of signal dimensions. Examples of such types of interference include narrowband interference (herein also referred to as ingress) or impulse/burst noise. The present invention also provides a solution where it may operate in the presence of simultaneous narrowband interference and impulse/burst noise and to substantially eliminate them both.

[0055] The present invention provides an approach for interference cancellation that provides a number of benefits including a completely linear method of canceling ingress that employed no DFE (Decision Feedback Equalizer) or SIC (Successive Ingress Cancellation). This approach can cancel wideband ingress and may be implemented in a relatively simple and efficient structure. Moreover, the present invention may be combined relatively easily, given its simple and efficient structure, with other methods and systems that may assist in the interference cancellation.

[0056] The present invention uses a linear combination of the unused dimensions (for example, the unused codes) to cancel the interference. This may be done after the de-spreader, or, equivalently, as part of the de-spreading process. There is no appreciable inter-code interference introduced and no decision errors are made as part of this process.

The allocation of unused codes reduces the capacity of the system by a small amount; for example, to 120/128 of the original capacity for a system of 128 codes where 8 unused codes are employed.

[0057] It is noted here that the specific examples of 120 active codes, and 8 unused codes in a system having 128 available codes is exemplary. Clearly, other embodiments may be employed (having different numbers of codes—both different numbers of used and unused) without departing from the scope and spirit of the invention.

[0058] From certain perspectives, the present invention may be viewed as being an extension of sub-dimensional modulation that is employed for TDMA (Time Division Multiple Access), and it may then be extended to S-CDMA (Synchronous Code Division Multiple Access). To begin this discussion, we consider an example case where 120 active codes are used and narrowband ingress (narrowband interference) is present. The remaining 8 codes are then transmitted as true zero symbols. At the receiver, the unused 8 codes are received with samples of the narrowband ingress. This information may then be used to cancel the ingress in the same manner that is used in sub-dimensional modulation. The 8 unused codes are considered as extra dimensions and the receiver is trained based on this information.

[0059] We continue on with 128 code example (8 of the codes being unused). By employing the 8 unused spreading codes, linear combinations of these 8 codes may be added to any other code that is transmitted from a transmitter to a receiver, and the resulting composite waveform can be used for de-spreading that one transmitted code. Since, ideally, no signal is present on any of these 8 codes (being zero codes), then little or no inter-code interference from the transmitters will be induced. In AWGN (Additive White Gaussian Noise), the inclusion of these additional de-spreading codes serves to merely increase the noise at the decision slicer for the code of interest. However, in the presence of interference, such as narrowband interference, some combination of these codes in the de-spreading process is operable to reduce the ingress enough to overcome the increased AWGN and make it worthwhile. Heuristically, the unused codes may correlate somewhat with the interference, and if so, may be used to “subtract” some component of the interference at the decision slicer, as a type of noise canceller.

[0060] The similarity of this approach is somewhat analogous to the functionality of an ICF (Ingress Cancellation Filter). In certain embodiments, a TDMA-only, CDMA-only, and/or a TDMA/CDMA burst receiver may be leveraged for this S-CDMA application, including the use of the Trench method or derivative that is mentioned below.

[0061] It is noted that the approach to reducing the interference power at the decision point using only the unused codes may not be optimal in certain embodiments, since using codes with data carried on them may offer some interference rejection overcoming the introduction of the transmitter inter-code interference. It is also noted that including “in use” codes would actually provide benefit in practical situations.

[0062] It is also noted that using a strict LMS (Least Mean Square) type of approach to converging 128 taps to the desired de-spreading code may prove laborious (in terms of requiring many iterations). This approach does not focus on just the unused codes, and has far more degrees of freedom than just finding 8 coefficients for the weightings of the 8 unused codes.

[0063] Analysis has shown that indeed there is great similarity in the formulation and solution of the optimal taps in the monic filter of the ICF for ingress cancellation, and in this application of unused spreading codes in ingress cancellation for S-CDMA. Both can be formulated in a LS (Least Squares) type of problem, with the ensuing typical solution taking form.

[0064] One advantage that may arise for the TDMA ICF case is when the matrix to be inverted is Toeplitz (a Toeplitz matrix in addition a matrix in which all the elements are the same along any diagonal that slopes from northwest to southeast), and thus admits significant computational advantages, such as discovered by William Trench.

[0065] However, in the S-CDMA formulation with unused codes, the matrix to be inverted is not Toeplitz, and the Trench approach does not apply. There still may be some computational advantages due to the underlying construction of the matrix to be inverted, but it may be that only the traditional numerical methods such as Cholesky decomposition may introduce simplification. The matrix to be inverted is at least of the form C^*RC , where $C=128 \times 8$, with each column orthogonal with the others (a sub-matrix of a Unitary matrix), and $R=128 \times 128$ and is Toeplitz, and $*$ stands for complex conjugate.

[0066] One implementation of the present invention may be described as shown below.

[0067] Let $R=R_{m,n}=E\{r^*(m)r(n)\}$, where $r(n)$ are noise and ingress samples, containing little or no signal. R is 128×128 , where the samples correspond to the noise in the chips of a spreading interval. The symbol $*$ denotes complex conjugate. This is the noise (or noise plus interference) covariance matrix.

[0068] Let $C=[c_1 c_2 c_3 c_4 c_5 c_6 c_7 c_8]$, where c_i =column of 128 chips of i^{th} unused spreading code. C is 128 rows by 8 columns.

[0069] Let:

[0070] dsc_{opt} =optimal de-spreading code for code-of-interest c_k , (written alternatively below)

$$dsc_{opt}=c_k+w_1c_1+w_2c_2+\dots+w_8c_8,$$

[0071] where dsc_{opt} is a column vector with 128 components, and w_i are scalar weighting coefficients.

[0072] Thus, $dsc_{opt}=[w_1 w_2 \dots w_8][c_k c_1 c_2 \dots c_8]$, and we can see that the optimal solution for the S-CDMA case indeed has a form similar to the monic filter in the TDMA ICF solution.

[0073] Let $w_{opt}=[w_1 w_2 \dots w_8]$ which provides the optimal de-spreading for signaling with the k^{th} spreading code.

[0074] It can be shown that $w_{opt}=-[C^TRC]^{-1}[C^TR]c_k$, where all the vectors, matrices, and notation are as defined above.

[0075] It is noted that with the ICF in TDMA,

$$w_{opt}=-[R]^{-1}[r_1 r_2 r_3 \dots r_{16}]^T,$$

where

$$R = \begin{bmatrix} r_0 & r_1 & r_2 & \dots & r_{16} \\ r_{16}^* & r_0 & r_1 & \dots & r_{15} \\ \vdots & & & \ddots & \vdots \\ r_1 & r_{15}^* & \dots & r_1^* & r_0 \end{bmatrix}$$

[0076] Another characteristic of the present invention is that the complexity of the method with the LS approach is high for large matrices compared to the ICF and Trench method with TDMA. However, this complexity is mitigated by the reduced matrix size resulting from the sub-space projection approach described here and below. From certain perspectives, the S-CDMA approach with unused codes may be viewed as not lending itself to the computational efficiencies of Trench approach or its derivatives.

[0077] However, using an LMS tap update approach has been found to work. The weights of the unused spreading codes, w_i , are updated in LMS fashion. In this method, the de-spreader for the code of interest is input to a decision slicer. The resulting complex error is computed. Similarly, each unused spreading code has its corresponding de-spreading operating. The result of the de-spreader corresponding to an unused spreading code is "signal," just as the "signal" rests in the various shift registers in the conventional FIR (Finite Impulse Response) filter in the normal LMS. The de-spread outputs for each of the unused codes is multiplied by the error vector, and then multiplied by a step size factor " $-\mu$ " and added to the existing tap weight, to update the tap weight.

[0078] With 8 unused spreading codes, there is a set of 8 tap weights for each used spreading code. Thus, with the 8 unused spreading codes, there are 8×120 tap weights to iterate.

[0079] This approach is much less computationally intensive than using an LS-based. The S-CDMA LMS approach introduces little additional computation when compared to operating the de-spreading codes themselves. This approach is beneficial for a number of reasons. It is computationally acceptable, in that, it limits the number of taps to only 8 (in our continuing example of 8 unused spreading codes), which almost certainly provides much more rapid convergence and less "tap noise." In addition, it eliminates from the search for optimal coefficients in the de-spreader those codes that are known to correspond to used codes.

[0080] FIG. 1 is a system diagram illustrating an embodiment of a CM communication system 100 that is built according to the present invention. The CM communication system includes a number of CMs (shown as a CM user #1 111, a CM user #2 115, . . . , and a CM user #n 121) and a CMTS 130. The CMTS 130 is a component that exchanges digital signals with CMs on a cable network.

[0081] Each of a number of CM users, shown as the CM user #1 111, the CM user #2 115, . . . , and the CM user #n 121, is able to communicatively couple to a CM network segment 199. A number of elements may be included within the CM network segment 199. For example, routers, splitters, couplers, relays, and amplifiers may be contained within the CM network segment 199 without departing from the scope and spirit of the invention.

[0082] The CM network segment 199 allows communicative coupling between a CM user and a cable headend transmitter 120 and/or a CMTS 130. In some embodiments, a cable CMTS is in fact contained within a headend transmitter. In other embodiments, the functionality of the cable CMTS and the headend transmitter are represented as two distinct functional blocks so that their respective contribution may be more easily appreciated and understood. This viewpoint is shown in the situation where the CMTS 130 is pictorially shown as being located externally to a cable headend transmitter 120. In the more common representation and implementation, a CMTS 135 is located within the cable headend

transmitter **120**. The combination of a CMTS and a cable headend transmitter may be referred to as being the “cable headend transmitter;” it then being understood that the cable headend transmitter supports the CMTS functionality. The CMTS **130** may be located at a local office of a cable television company or at another location within a CM communication system. In the following description, the CMTS **130** is used for illustration; yet, the same functionality and capability as described for the CMTS **130** may equally apply to embodiments that alternatively employ the CMTS **135**. The cable headend transmitter **120** is able to provide a number of services including those of audio, video, telephony, local access channels, as well as any other service known in the art of cable systems. Each of these services may be provided to the one or more CM users **111, 115, . . . , and 121**.

[0083] In addition, through the CMTS **130**, the CM users **111, 115, . . . , 121** are able to transmit and receive data from the Internet, . . . , and/or any other network to which the CMTS **130** is communicatively coupled. The operation of a CMTS, at the cable-provider’s head-end, may be viewed as providing many of the same functions provided by a digital subscriber line access multiplexor (DSLAM) within a digital subscriber line (DSL) system. The CMTS **130** takes the traffic coming in from a group of customers on a single channel and routes it to an Internet Service Provider (ISP) for connection to the Internet, as shown via the Internet access. At the head-end, the cable providers will have, or lease space for a third-party ISP to have, servers for accounting and logging, dynamic host configuration protocol (DHCP) for assigning and administering the Internet protocol (IP) addresses of all the cable system’s users, and typically control servers for a protocol called Data Over Cable Service Interface Specifications (DOCSIS), the major standard used by U.S. cable systems in providing Internet access to users.

[0084] The downstream information flows to all of the connected CM users **111, 115, . . . , 121**; this may be viewed to be in a manner that is similar to that manner within an Ethernet network. The individual network connection, within the CM network segment **199**, decides whether a particular block of data is intended for it or not. On the upstream side, information is sent from the CM users **111, 115, . . . , 121** to the CMTS **130**; on this upstream transmission, the users within the CM users **111, 115, . . . , 121** to whom the data is not intended do not see that data at all. As an example of the capabilities provided by a CMTS, the CMTS will enable as many as 1,000 users to connect to the Internet through a single 6 MHz channel. Since a single channel is capable of 30-40 megabits per second of total throughput, this means that users may see far better performance than is available with standard dial-up modems. Embodiments implementing the present invention are described below and in the various Figures that show the data handling and control within one or both of a CM and a CMTS within a CM system that operates by employing S-CDMA (Synchronous Code Division Multiple Access).

[0085] The CMs of the CM users **111, 115, . . . , 121** and the CMTS **130** communicate synchronization information to one another to ensure proper alignment of transmission from the CM users **111, 115, . . . , 121** to the CMTS **130**. This is where the synchronization of the S-CDMA communication systems is extremely important. When a number of the CMs all transmit their signals at a same time such that these signals are received at the CMTS **130** on the same frequency and at the same time, they must all be able to be properly de-spread and decoded for proper signal processing.

[0086] Each of the CMs users **111, 115, . . . , 121** is located a respective transmit distance from the CMTS **130**. In order to achieve optimum spreading diversity and orthogonality for the CMs users **111, 115, . . . , 121** to transmission of the CMTS **130**, each of the CM transmissions must be synchronized so that it arrives, from the perspective of the CMTS **130**, synchronous with other CM transmissions. In order to achieve this goal, for a particular transmission cycle, each of the CMs **111, 115, . . . , 121** will typically transmit to the CMTS **130** at a respective transmission time, which will likely differ from the transmission times of other CMs. These differing transmission times will be based upon the relative transmission distance between the CM and the CMTS **130**. These operations may be supported by the determination of the round trip delays (RTPs) between the CMTS **130** and each supported CM. With these RTPs determined, the CMs may then determine at what point to transmit their S-CDMA data so that all CM transmissions will arrive synchronously at the CMTS **130**.

[0087] The present invention enables interference cancellation within the CMTS **130**, as shown in a functional block **131**. The present invention may also be implemented to support interference cancellation within any one of the CMs **111, 115, . . . , 121**; the particular implementation of interference cancellation is shown as a functional block **122** within the CM **122**, yet it is understood that the interference cancellation functionality may also be supported within the other CMs as well. The CMTS **130** receives an input spread signal and is operable to perform despreading and interference cancellation according to the present invention. The CMTS **130** is operable to employ a linear combiner, that uses as inputs complex valued combining weights to the particular codes that are selectively used to assist in the interference cancellation of one of the de-spread signals that is de-spread from the input spread signal that the CMTS **130** receives. Alternatively, the present invention may be viewed as employing at least one of an adapted code and an adapted code matrix to perform interference cancellation according to the present invention.

[0088] FIG. 2 is a system diagram illustrating another embodiment of a CM communication system **200** that is built according to the present invention. From certain perspectives, the FIG. 2 may be viewed as a communication system allowing bi-directional communication between a customer premise equipment (CPE) **240** and a network. In some embodiments, the CPE **240** is a personal computer or some other device allowing a user to access an external network. The network may be a wide area network (WAN) **280**, or alternatively, the Internet **290** itself. For example, the CM communication system **200** is operable to allow Internet protocol (IP) traffic to achieve transparent bi-directional transfer between a CMTS-network side interface (CMTS-NSI: viewed as being between the CMTS **230** and the Internet **290**) and a CM to CPE interface (CMCI: viewed as being between the CM **210** and the CPE **240**).

[0089] The WAN **280**, and/or the Internet **290**, is/are communicatively coupled to the CMTS **230** via a CMTS-NSI. The CMTS **230** is operable to support the external network termination, for one or both of the WAN **280** and the Internet **290**. The CMTS **230** includes a modulator and a demodulator to support transmitter and receiver functionality to and from a CM network segment **299**. The receiver functionality within the CMTS **230** is operable to support interference cancellation functionality **231** according to the present invention. It is

also noted that there may be embodiment where the CM 210 is also operable to support interference cancellation functionality using the present invention, as shown by a functional block 211. Implementing interference cancellation in the transmitter prevents noise enhancement that occurs when interference cancellation is performed in the receiver.

[0090] A number of elements may be included within the CM network segment 299. For example, routers, splitters, couplers, relays, and amplifiers may be contained within the CM network segment 299 without departing from the scope and spirit of the invention. The CM network segment 299 allows communicative coupling between a CM user and the CMTS 230. The FIG. 2 shows just one of many embodiments where the interference cancellation, performed according to the present invention, may be performed to provide for improved operation within a communication system.

[0091] FIG. 3A is a system diagram illustrating an embodiment of a cellular communication system 300A that is built according to the present invention. A mobile transmitter 310 has a local antenna 311. The mobile transmitter 310 may be any number of types of transmitters including a cellular telephone, a wireless pager unit, a mobile computer having transmit functionality, or any other type of mobile transmitter. The mobile transmitter 310 transmits a signal, using its local antenna 311, to a base station receiver 340 via a wireless communication channel. The base station receiver 340 is communicatively coupled to a receiving wireless tower 349 to be able to receive transmission from the local antenna 311 of the mobile transmitter 310 that have been communicated via the wireless communication channel. The receiving wireless tower 349 communicatively couples the received signal to the base station receiver 340.

[0092] The base station receiver 340 is then able to support interference cancellation functionality according to the present invention, as shown in a functional block 341, on the received signal. The FIG. 3A shows yet another of the many embodiments where the interference cancellation, performed according to the present invention, may be performed to provide for improved operation within a communication system.

[0093] FIG. 3B is a system diagram illustrating another embodiment of a cellular communication system that is built according to the present invention. From certain perspectives, the FIG. 3B may be viewed as being the reverse transmission operation of the cellular communication system 300B of the FIG. 3A. A base station transmitter 320 is communicatively coupled to a transmitting wireless tower 321. The base station transmitter 320, using its transmitting wireless tower 321, transmits a signal to a local antenna 339 via a wireless communication channel. The local antenna 339 is communicatively coupled to a mobile receiver 330 so that the mobile receiver 330 is able to receive transmission from the transmitting wireless tower 321 of the base station transmitter 320 that have been communicated via the wireless communication channel. The local antenna 339 communicatively couples the received signal to the mobile receiver 330. It is noted that the mobile receiver 330 may be any number of types of transmitters including a cellular telephone, a wireless pager unit, a mobile computer having transmit functionality, or any other type of mobile transmitter.

[0094] The mobile receiver 330 is then able to support interference cancellation functionality according to the present invention, as shown in a functional block 331, on the received signal. The FIG. 3B shows yet another of the many

embodiments where the interference cancellation functionality, performed according to the present invention, may be performed to provide for improved operation within a communication system.

[0095] It is also noted that the embodiments described above within the FIGS. 3A and 3B may operate in conjunction within a single communication system. That is to say, a mobile unit (that supports both transmit and receive functionality) may be implemented to support interference cancellation functionality during receipt of signals while the base station device (that supports both transmit and receive functionality) may also be implemented to support interference cancellation functionality during receipt of signals. This way, both devices are operable to support the interference cancellation functionality according to the present invention at both ends of the communication link. This dual-end interference cancellation functionality is also true within other of the various embodiments described herein that illustrate both ends of a communication link.

[0096] It is further noted that the embodiments described above within the FIGS. 3A and 3B may operate in conjunction within a single communication system from yet another perspective. A mobile transmitter may be implemented to support interference cancellation functionality during signal processing and transmission of its signals to a base station receiver. Similarly, a base station transmitter may be implemented to support interference cancellation functionality during signal processing and transmission of its signals to a mobile unit receiver. This may be performed, at least in part, by adjusting a transmitted spectrum to meet a desired spectral mask. It may be desirable to attenuate certain portions of the spectrum using the subspace canceller. In these applications the canceller is predominantly located in the transmitter. Further detail of this interference cancellation within a transmitter device is presented below. This adjusting of a transmitted spectrum to meet a desired spectral mask may be performed within any of the various embodiments that include a transmitter that transmits a signal to a receiver according to the present invention.

[0097] FIG. 4 is a system diagram illustrating an embodiment of a satellite communication system 400 that is built according to the present invention. A transmitter 420 is communicatively coupled to a wired network 410. The wired network 410 may include any number of networks including the Internet, proprietary networks, and other wired networks. The transmitter 420 includes a satellite earth station 451 that is able to communicate to a satellite 453 via a wireless communication channel. The satellite 453 is able to communicate with a receiver 430. The receiver 430 is also located on the earth. Here, the communication to and from the satellite 453 may cooperatively be viewed as being a wireless communication channel, or each of the communication to and from the satellite 453 may be viewed as being two distinct wireless communication channels.

[0098] For example, the wireless communication "channel" may be viewed as not including multiple wireless hops in one embodiment. In other embodiments, the satellite 453 receives a signal received from the satellite earth station 451, amplifies it, and relays it to the receiver 430; the receiver 430 may include terrestrial receivers such as satellite receivers, satellite based telephones, and satellite based Internet receivers, among other receiver types. In the case where the satellite 453 receives a signal received from the satellite earth station 451, amplifies it, and relays it, the satellite 453 may be viewed

as being a “transponder.” In addition, other satellites may exist that perform both receiver and transmitter operations. In this case, each leg of an up-down transmission via the wireless communication channel would be considered separately. The wireless communication channel between the satellite 453 and a fixed earth station would likely be less time-varying than the wireless communication channel between the satellite 453 and a mobile station.

[0099] In whichever embodiment, the satellite 453 communicates with the receiver 430. The receiver 430 may be viewed as being a mobile unit in certain embodiments (employing a local antenna 412); alternatively, the receiver 430 may be viewed as being a satellite earth station 452 that may be communicatively coupled to a wired network in a similar manner that the satellite earth station 451, within the transmitter 420, communicatively couples to a wired network. In both situations, the receiver 430 is able to support interference cancellation functionality, as shown in a functional block 431, according to the present invention. For example, the receiver 430 is able to perform interference cancellation, as shown in a functional block 431, on the signal received from the satellite 453. The FIG. 4 shows yet another of the many embodiments where the interference cancellation, performed according to the present invention, may be performed to provide for improved receiver performance.

[0100] FIG. 5A is a system diagram illustrating an embodiment of a microwave communication system 500A that is built according to the present invention. A tower transmitter 511 includes a wireless tower 515. The tower transmitter 511, using its wireless tower 515, transmits a signal to a tower receiver 512 via a wireless communication channel. The tower receiver 512 includes a wireless tower 516. The wireless tower 516 is able to receive transmissions from the wireless tower 515 that have been communicated via the wireless communication channel. The tower receiver 512 is then able to support interference cancellation functionality, as shown in a functional block 533. The FIG. 5A shows yet another of the many embodiments where interference cancellation, performed according to the present invention, may be performed to provide for improved receiver performance.

[0101] FIG. 5B is a system diagram illustrating an embodiment of a point-to-point radio communication system 500B that is built according to the present invention. A mobile unit 551 includes a local antenna 555. The mobile unit 551, using its local antenna 555, transmits a signal to a local antenna 556 via a wireless communication channel. The local antenna 556 is included within a mobile unit 552. The mobile unit 552 is able to receive transmissions from the mobile unit 551 that have been communicated via the wireless communication channel. The mobile unit 552 is then able to support interference cancellation functionality, as shown in a functional block 553, on the received signal. The FIG. 5B shows just yet another of the many embodiments where interference cancellation, performed according to the present invention, may be performed to provide for improved receiver performance.

[0102] FIG. 6 is a system diagram illustrating an embodiment of a high definition (HDTV) communication system 600 that is built according to the present invention. An HDTV transmitter 610 includes a wireless tower 611. The HDTV transmitter 610, using its wireless tower 611, transmits a signal to an HDTV set top box receiver 620 via a wireless communication channel. The HDTV set top box receiver 620 includes the functionality to receive the wireless transmitted signal. The HDTV set top box receiver 620 is also commu-

nicatively coupled to an HDTV display 630 that is able to display the demodulated and decoded wireless transmitted signals received by the HDTV set top box receiver 620.

[0103] The HDTV set top box receiver 620 is then able to support interference cancellation functionality, as shown in a functional block 623 to provide for improved receiver performance. The FIG. 6 shows yet another of the many embodiments where interference cancellation, performed according to the present invention, may be performed to provide for improved receiver performance.

[0104] FIG. 7 is a system diagram illustrating an embodiment of a communication system that is built according to the present invention. The FIG. 7 shows communicative coupling, via a communication channel 799, between two transceivers, namely, a transceiver 701 and a transceiver 702. The communication channel 799 may be a wireline communication channel or a wireless communication channel.

[0105] Each of the transceivers 701 and 702 includes a transmitter and a receiver. For example, the transceiver 701 includes a transmitter 749 and a receiver 740; the transceiver 702 includes a transmitter 759 and a receiver 730. The receivers 740 and 730, within the transceivers 701 and 702, respectively, are each operable to support interference cancellation functionality according to the present invention. This will allow improved signal processing for both of the transceivers 701 and 702. For example, the receiver 740, within the transceiver 701, is able to support interference cancellation functionality, as shown in a functional block 741, on a signal received from the transmitter 759 of the transceiver 702. Similarly, the receiver 730, within the transceiver 702, is able to support interference cancellation functionality, as shown in a functional block 731, on a signal received from the transmitter 749 of the transceiver 701.

[0106] If desired in certain embodiments, the transmitters 749 and 759, within the transceivers 701 and 702, respectively, are each operable to support interference cancellation functionality according to the present invention. This will also allow improved signal processing for both of the transceivers 701 and 702. For example, the transmitter 749, within the transceiver 701, is able to support interference cancellation functionality, as shown in a functional block 748, on a signal that is to be transmitted from the transmitter 759 of the transceiver 702. Similarly, the transmitter 759, within the transceiver 702, is able to support interference cancellation functionality, as shown in a functional block 758, on a signal that is to be transmitted from the transmitter 759 of the transceiver 702.

[0107] This interference cancellation functionality, within the transmitters 749 and 759, respectively, may be performed, at least in part, by adjusting a transmitted spectrum to meet a desired spectral mask according to the present invention. The FIG. 7 shows yet another of the many embodiments where interference cancellation, performed according to the present invention, may be performed to provide for improved performance.

[0108] FIG. 8 is a system diagram illustrating another embodiment of a communication system 800 that is built according to the present invention. The FIG. 8 shows communicative coupling, via a communication channel 899, between a transmitter 849 and a receiver 830. The communication channel 899 may be a wireline communication channel or a wireless communication channel. The receiver 830 is operable to support interference cancellation, as shown in a functional block 831, according to the present invention. The

FIG. 8 shows yet another of the many embodiments where interference cancellation, performed according to the present invention, may be performed to provide for improved performance.

[0109] In certain embodiments, the transmitter 849 is also operable to support interference cancellation, as shown in a functional block 848, according to the present invention. This interference cancellation functionality, within the transmitter 849, may be performed, at least in part, by adjusting a transmitted spectrum to meet a desired spectral mask according to the present invention. For example, the interference cancellation functionality of the present invention may be located at the transmitter 849, the receiver 830, or partly in each (as shown by the functional blocks 848 and 831). In many of the various embodiments described herein, the interference cancellation functionality has been located in a receiver of a communication system. The following describes one embodiment of how the interference cancellation functionality may be located at the transmitter. The unused codes, instead of being modulated at the transmitter with zero symbols, are modulated with a linear combination of the desired signals from the used codes. In the case of narrowband interference, the resulting transmitted signal will have a null on the interferer.

[0110] FIG. 9 is a system diagram illustrating an embodiment of a CMTS system 900 that is built according to the present invention. The CMTS system 900 includes a CMTS medium access controller (MAC) 930 that operates with a number of other devices to perform communication from one or more CMs to a WAN 980. The CMTS MAC 930 may be viewed as providing the hardware support for MAC-layer per-packet functions including fragmentation, concatenation, and payload header suppression that all are able to offload the processing required by a system central processing unit (CPU) 972. This will provide for higher overall system performance. In addition, the CMTS MAC 930 is able to provide support for carrier class redundancy via timestamp synchronization across a number of receivers, shown as a receiver 911, a receiver 912, and a receiver 913 that are each operable to receive upstream analog inputs. In certain embodiments, each of the receivers 911, 912, and 913 are dual universal advanced TDMA/CDMA (Time Division Multiple Access/Code Division Multiple Access) PHY-layer burst receivers. That is to say, each of the receivers 911, 912, and 913 includes at least one TDMA receive channel and at least one CDMA receive channel; in this case, each of the receivers 911, 912, and 913 may be viewed as being multi-channel receivers.

[0111] In addition, the CMTS MAC 930 may be operated remotely with a routing/classification engine 979 that is located externally to the CMTS MAC 930 for distributed CMTS applications including mini fiber node applications. Moreover, a Standard Programming Interface (SPI) master port may be employed to control the interface to the receivers 911, 912, and 913 as well as to a downstream modulator 920.

[0112] The CMTS MAC 930 may be viewed as being a highly integrated CMTS MAC integrated circuit (IC) for use within the various DOCSIS and advanced TDMA/CDMA physical layer (PHY-layer) CMTS products. The CMTS MAC 930 may employ hardware engines for upstream and downstream paths. The upstream processor design is segmented and uses two banks of Synchronous Dynamic Random Access Memory (SDRAM) to minimize latency on internal buses. The two banks of SDRAM used by the upstream

processor are shown as upstream SDRAM 975 (operable to support keys and reassembly) and SDRAM 976 (operable to support Packaging, Handling, and Storage (PHS) and output queues). The upstream processor performs Data Encryption Standard (DES) decryption, fragment reassembly, de-concatenation, payload packet expansion, packet acceleration, upstream Management Information Base (MIB) statistic gathering, and priority queuing for the resultant packets. Each output queue can be independently configured to output packets to either a Personal Computer Interface (PCI) or a Gigabit Media Independent Interface (GMII). DOCSIS MAC management messages and bandwidth requests are extracted and queued separately from data packets so that they are readily available to the system controller.

[0113] The downstream processor accepts packets from priority queues and performs payload header suppression, DOCSIS header creation, DES encryption, Cyclic Redundancy Check (CRC) and Header Check Sequence (of the DOCSIS specification), Moving Pictures Experts Group (MPEG) encapsulation and multiplexing, and timestamp generation on the in-band data. The CMTS MAC 930 includes an out-of-band generator and TDMA PHY-layer (and/or CDMA PHY-layer) interface so that it may communicate with a CM device's out-of-band receiver for control of power management functions. The downstream processor will also use SDRAM 977 (operable to support PHS and output queues). The CMTS MAC 930 may be configured and managed externally via a PCI interface and a PCI bus 971.

[0114] Each of the receivers 911, 912, and 913 is operable to support interference cancellation functionality. For example, the receiver 911 is operable to support interference cancellation functionality, as shown in a functional block 991; the receiver 912 is operable to support interference cancellation functionality, as shown in a functional block 992; and the receiver 913 is operable to support interference cancellation functionality, as shown in a functional block 993. The FIG. 9 shows yet another embodiment in which interference cancellation may be performed according to the present invention. Any of the functionality and operations described in the other embodiments may be performed within the context of the CMTS system 900 without departing from the scope and spirit of the invention.

[0115] FIG. 10 is a system diagram illustrating an embodiment of a burst receiver system 1000 that is built according to the present invention. The burst receiver system 1000 includes at least one multi-channel receiver 1010. The multi-channel receiver 1010 is operable to receive a number of upstream analog inputs that are transmitted from CMs. The upstream analog inputs may be in the form of either TDMA (Time Division Multiple Access) and/or CDMA (Code Division Multiple Access) format. A number of receive channels may be included within the multi-channel receiver 1010.

[0116] For example, the multi-channel receiver 1010 is operable to support a number of TDMA receive channels 1020 (shown as TDMA signal 1 and TDMA signal 2) and to support interference cancellation functionality, as shown in a functional block 1021, for those received TDMA signals. The multi-channel receiver 1010 is operable to support a number of TDMA receive channels 1030 (shown as CDMA signal 1 and CDMA signal 2) and to support interference cancellation functionality, as shown in a functional block 1031, for those received CDMA signals. Generically speaking, the multi-channel receiver 1010 is operable to support a number of receive channels 1040 (shown as received signal 1 and

received signal 2) and to support interference cancellation functionality, as shown in a functional block 1041, for those received signals. The multi-channel receiver 1010 of the FIG. 10 is operable to interface with a CMTS MAC. The burst receiver system 1000 may include a number of multi-channel receivers that are each operable to interface with the CMTS MAC.

[0117] In certain embodiments, the multi-channel receiver 1010 provides a number of various functionalities. The multi-channel receiver 1010 may be a universal headend advanced TDMA PHY-layer QPSK/QAM (Quadrature Phase Shift Keying/Quadrature Amplitude Modulation) burst receiver; the multi-channel receiver 1010 also include functionality to be a universal headend advanced CDMA PHY-layer QPSK/QAM burst receiver; or the multi-channel receiver 1010 also include functionality to be a universal headend advanced TDMA/CDMA PHY-layer QPSK/QAM burst receiver offering both TDMA/CDMA functionality. The multi-channel receiver 1010 may be DOCSIS/EuroDOCSIS based, IEEE 802.14 compliant. The multi-channel receiver 1010 may be adaptable to numerous programmable demodulation including BPSK (Binary Phase Shift Keying), and/or QPSK, 8/16/32/64/128/256/516/1024 QAM. The multi-channel receiver 1010 is adaptable to support variable symbols rates as well. Other functionality may likewise be included to the multi-channel receiver 1010 without departing from the scope and spirit of the invention. Such variations and modifications may be made to the communication receiver.

[0118] FIG. 11 is a system diagram illustrating an embodiment of a single chip DOCSIS/EuroDOCSIS CM system 1100 that is built according to the present invention. The single chip DOCSIS/EuroDOCSIS CM system 1100 includes a single integration and offering a very high level of performance. A coaxial cable in input to a DiPlexer to provide CM access to the single chip DOCSIS/EuroDOCSIS CM system 600. The DiPlexer communicatively couples to a CMOS (Complementary Metal Oxide Semiconductor) tuner. The CMOS tuner may be implemented with a companion part that includes a low noise amplifier (LNA) and performs radio frequency (RF) automatic gain control (AGC). This two part solution is operable to support 64 and 256 QAM. These two parts operate cooperatively with the single chip DOCSIS/EuroDOCSIS CM 1110. The CMOS tuner may be operable to support an intermediate frequency (IF) output frequency range of 36-44 MHz, and specifically support the 36.125 and 43.75 MHz center frequencies for the Phase Alteration Line (PAL) and National Television System Committee (NTSC) standards. Also, the CMOS tuner and the LNA and RF AGC are DOCSIS and EuroDOCSIS standard supportable.

[0119] However, it is also noted that the CMOS tuner is operable to perform direct RF to baseband (BB) frequency transformation without requiring the IF transformation. The received signal from the DiPlexer. An external bandpass Surface Acoustic Wave (SAW) filter removes the channels distant from the desired signal.

[0120] The output from the SAW filter is then passed to the single chip DOCSIS/EuroDOCSIS CM 1110. The single chip DOCSIS/EuroDOCSIS CM 1110 is supported by Synchronous Dynamic Random Access Memory (SDRAM) and Flash. In addition, the single chip DOCSIS/EuroDOCSIS CM 1110 supports both Ethernet and USB interfacing to any other devices that may exist within the single chip DOCSIS/EuroDOCSIS CM system 1100. The FIG. 11 shows yet another embodiment in which interference cancellation may

be performed according to the present invention. The interference cancellation functionality may be supported directly within the single chip DOCSIS/EuroDOCSIS CM 1110. The single chip DOCSIS/EuroDOCSIS CM system 1100 shows an application context of yet another implementation of a device that may perform the present invention.

[0121] FIG. 12 is a system diagram illustrating another embodiment of a single chip DOCSIS/EuroDOCSIS CM system 1200 that is built according to the present chip DOCSIS/EuroDOCSIS CM 1210 that combines an RF receiver with an advanced QAM demodulator, an advanced QAM and S-CDMA modulator/transmitter, a complete DOCSIS 2.0 Media Access Controller (MAC), a 200 MHz MIPS32 Communication Processor, a 16 bit, 100 MHz SDRAM interface, 10/100 Ethernet MAC with integrated transceiver and Media Independent Interface (MII), and a USB 1.1 controller with integrated transceiver.

[0122] The QAM receiver directly samples a tuner output (such as the CMOS tuner of the FIG. 6) with an 11 bit analog to digital converter (ADC) and input AGC amplifier. The receiver digitally re-samples and demodulates the signal with recovered clock and carrier timing, filters and equalizes the data, and passes soft decisions to an ITU-T J.83 Annex A/B/C compatible decoder. The receiver supports variable symbol rate 4/16/32/64/128/256/1024 QAM Forward Error Correction (FEC) decoding. The final received data stream is delivered in a serial MPEG-2 transport format. All gain, clock, and carrier, acquisition and tracking loops are integrated in the QAM receiver.

[0123] The upstream transmitter takes burst or continuous data, provides FEC encoding and pre-equalization for DOCSIS applications, filters and applies 2/4/8/16/64/256 QAM or S-CDMA modulation to the data stream, amplifies the signal through the integrated upstream power amplifier and provides a direct 0-65 MHz analog output.

[0124] The MAC of the single chip DOCSIS/EuroDOCSIS CM 1210 includes all features required for full DOCSIS 1.0, 1.1, and 2.0 compliance, including full support for baseline privacy (BPI+) encryption and decryption. Single-user support includes four SIDS (Standard Interoperable Datalink System) in downstream, four DA perfect match filters, a 256 entry CAM for multicast/unicast hash filter and four independent upstream queues for simultaneous support of Quality of Service (QoS) and BE traffic. To enhance operational support, the MAC of the MAC of the single chip DOCSIS/EuroDOCSIS CM 1210 provides extended Network Management MIB/Diagnostic features, as well as immediate UCC (on the fly) using independent resets for downstream and upstream queues and both individual queue reset/flush for upstream queues. The MAC of the single chip DOCSIS/EuroDOCSIS CM 1210 uses advance PROPANE™ techniques to provide packet acceleration to significantly improve upstream channel utilization.

[0125] With the incorporation of an upstream power amplifier, the MAC of the single chip DOCSIS/EuroDOCSIS CM 1210 allows a complete CM to be assembled with a minimal set of external components. When used with a CMOS tuner, such as the CMOS tuner of the FIG. 11, a very low cost solution for a high performance, single user DOCSIS 2.0 CM is provided. The MAC of the single chip DOCSIS/EuroDOCSIS CM 1210 of the FIG. 12 is operable to support all digital reference frequency locking functionality according to the present invention. The FIG. 12 shows yet another embodiment where interference cancellation functionality may be

supported according to the present invention. The interference cancellation functionality may be viewed as being supported and performed within the DOCSIS 2.0 MAC of the single chip DOCSIS/EuroDOCSIS CM 1210 of the FIG. 12.

[0126] FIG. 13 is a system diagram illustrating an embodiment of a single chip wireless modem system 1300 that is built according to the present invention. The single chip wireless modem system 1300 includes a single chip wireless modem 1310 that is operable to support a variety of functionalities. The single chip wireless modem system 1300 is operable to perform wireless LAN operation using an 802.11 radio that is operable to communicatively couple to an external device that is wireless capable (example shown as the pen computer having wireless functionality). The single chip wireless modem 1310 of the single chip wireless modem system 1300 employs a 10/100 Ethernet PHY and an HPNA (Home Phoneline Network Alliance) analog front end (AFE) that is operable to interface with the HPNA 2.0 network. The single chip wireless modem 1310 of the single chip wireless modem system 1300 also supports capability to communicate with an external device via a USB 1.1 interface.

[0127] The single chip wireless modem 1310 of the single chip wireless modem system 1300 is compatible with existing cable modem application code. In addition, the single chip wireless modem 1310 supports advanced QAMLink® modulation/demodulation TP provide for higher throughputs and performance in noisy plant environments. The 802.11b MAC and baseband allow for wireless connectivity as mentioned above. In addition, the integrated HPNA 2.0 MAC supports high-speed multimedia services over phone lines. The integrated 10/100 Ethernet and USB 1.1 with integrated transceiver provide for a low cost CPE (Customer Premises Equipment), and the MPI interfaces provide for great flexibility through additional connectivity options. The single chip wireless modem 1310 is a part of a comprehensive solution that is operable to support certifiable DOCSIS/EuroDOCSIS 1.1 software as well as supporting residential gateway software including Firewall, NAT and DHCP. The FIG. 13 shows yet another embodiment where interference cancellation functionality may be supported according to the present invention. The interference cancellation functionality may be viewed as being supported and performed within the single chip wireless modem 1310 of the single chip wireless modem system 1300.

[0128] FIG. 14 is a system diagram illustrating another embodiment of a single chip wireless modem system 1400 that is built according to the present invention. The single chip wireless modem system 1400 includes a single chip wireless modem that is operable to support a variety of functionalities. The single chip wireless modem of the single chip wireless modem system 1300 integrates the DOCSIS/EuroDOCSIS 2.0 cable based modem with a 2/4/8/16/32/64/128/256/1024 QAM downstream receiver with Annex A, B, C FEC support. In addition, the single chip wireless modem integrates the DOCSIS/EuroDOCSIS 2.0 cable based modem with 2/4/8/16/32/64/128/256 QAM FA-TDMA and S-CDMA. The 802.11b wireless MAC and baseband are also integrated on the single chip wireless modem. A number of other functional blocks are also integrated thereon, including, a 300 MHz MIPS32 CPU, a 32 bit 100MHz SDRAM/DDR controller, an integrated upstream amplifier, an integrated IP SEC engine, an integrated advance PROPANE™ packet accelerator, a 12 Mbps USB 1.1 slave port with integrated transceiver, a 10/100 Ethernet MAC/PHY with MII interface, an MPI expansion

bus (that supports PCI, Cardbus, and PCMCIA interfaces), a single 28 MHz reference crystal, and ability to operate using voltages of 1.8 V and/or 3.3 V.

[0129] The advanced QAMLink® technology of the single chip wireless modem, compliant with DOCSIS 2.0, supports up to 1024 QAM downstream modulation formats and both FA-TDMA and S-CDMA, with 256 QAM upstream modulation formats. This advanced technology provides a higher throughput and superior performance in noise plant environments, paving the way for symmetrical services, such as video conferencing.

[0130] The single chip wireless modem integrates both wireless and wireline networking functions for distributing broadband content throughout the home. An 802.11b solution is provided for wireless connectivity, while both 10/100 Ethernet and 32 Mbps HPNA 2.0 solutions provide wired connectivity. HPNA 2.0 allows multimedia services to be streamed across existing home phone lines.

[0131] The PROPANE™ technology provides bandwidth and performance enhancements to existing cable plants allowing up to twice as many subscribers per node, thereby minimizing the need for node splits. The FIG. 14 shows yet another embodiment where interference cancellation functionality may be supported according to the present invention. The interference cancellation functionality may be viewed as being supported and performed within the single chip wireless modem of the single chip wireless modem system 1400.

[0132] FIG. 15 is a diagram illustrating an embodiment of a vector de-spreader 1500 that is built according to the present invention. The following description of embodiments of the present invention using the FIGS. 15, 16, 17, and 18 are made within the context of the DOCSIS 2.0 system. This system uses S-CDMA modulation for the upstream with 128 orthogonal codes. In the example there are 120 active (data-carrying) codes, with 8 unused codes. This example is for illustrative purposes only, and should by no means limit the scope of the invention. Again, it is noted that the specific examples of 120 active codes, and 8 unused codes in a system having 128 available codes is exemplary. Clearly, other embodiments may be employed (having different numbers of codes—both different numbers of used and unused) without departing from the scope and spirit of the invention.

[0133] The FIG. 15 depicts a vector de-spreader, arranged according to the present invention, consisting of 128 individual de-spreaders. De-spreading is the process of multiplying by a given code sequence and summing (or integrating) over the chips of a spreading sequence, in this case the length of the code, 128 chips. Each scalar de-spreader performs the function of de-spreading the received signal (input spread signal to be de-spread) using a single de-spreading code (c_1, \dots, c_{128}). There are 128 orthogonal de-spreading codes in the present example.

[0134] FIG. 16 is a diagram illustrating an embodiment of an interference canceller 1200 that is built according to the present invention. The spread input signal x , consisting of the sum of multiple spreading codes modulating multiple data streams, enters the diagram at the left. The undesired interference n is added to the signal. The signal is applied to the vector de-spreader, which de-spreads each of the 128 codes. The upper 8 codes are not used for data transmission and are modulated with numerically zero-valued symbols instead of data. Clearly, there may be embodiments where other numerically constant-valued symbols may be employed instead of

data as well. Further, the symbol may contain data represented as a reduced constellation, such as BPSK or QPSK, on the “unused” codes.

[0135] One of the 120 data-carrying codes, code d_s , is identified for illustration in the FIG. 16. In order to cancel the interference, the de-spreader output d_s is processed in a linear combiner, where it is summed with a linear combination of the 8 de-spreader outputs from the zero-modulation codes d_1 - d_8 . The complex-valued combining weights applied to these codes are w_1 - w_8 , respectively. These weights are computed in a weight computation method as shown in the lower right hand corner of the FIG. 16 using the weight computation functionality.

[0136] The weight computation functionality may employ a method that utilizes the input spread signal plus interference, and may utilize some system outputs if an iterative method is used. Weight computation methods that have been found valuable are the LMS (least mean square) method and the LS (least squares) method. The result of the linear combination is the output \hat{d}_s , which is the data stream d_s with the interference largely removed. Although not shown in the figure, the same linear combiner structure is applied to the other 119 codes as well (all of the other active codes besides the code d_s). In each case, the desired code (one of the 120 “active” or data-carrying codes) is applied to a linear combiner to cancel the interference from that code. For each data-carrying code, the same 8 zero-modulation codes are summed with the desired code, but for each active code the weights w_1 - w_8 are in general unique.

[0137] An alternative viewpoint is to define the adapted code as

$$c_a(n) = c_s(n) + \sum_{k=1}^{N_u} w_k c_k(n)$$

[0138] that is, the desired code plus the linear combination of the weights times the unused (“inactive”) codes. In this view, the adapted code is a modified code with complex coefficients, which is used instead of the code c_s to de-spread a single desired signal from a single modulated code, while simultaneously canceling the interference.

[0139] This approach can be extended to matrix notation by defining the adapted code matrix as

$$C_{adapted} = C_{used} + WC_{unused}$$

[0140] where:

[0141] $C_{adapted}$ =adapted code matrix, dimension $(N_c - N_u) \times 128$, for example, 120×128

[0142] C_{used} =matrix whose rows are the used codes in the original code matrix, dimension $(N_c - N_u) \times N_c$, for example, 120×128

[0143] W =matrix whose rows are the adaptive weight vectors for each unused code, dimension $(N_c - N_u) \times N_u$, for example, 120×8

[0144] C_{unused} =matrix whose rows are the unused codes in the original code matrix, dimension $N_u \times N_c$, for example, 8×128

[0145] N_c =number of total codes=number of chips in each code, for example, 128

[0146] N_u =number of unused codes, for example, 8

[0147] In this view, the adapted code matrix is a modified code matrix with complex coefficients, which is used instead

of the code matrix C to de-spread the desired signals from all used codes, while simultaneously canceling the interference on all used codes.

[0148] It is noted that that the unused codes may be de-spread as well, and this side information, though not data-carrying, is of use in characterizing the interference environment.

[0149] It is also noted that the weight computation functionality may be performed offline, and these pre-computed complex-valued combining weights, w_1 - w_8 , may then be stored in memory and/or a look up table (LUT) that may be used to provide the complex-valued combining weights, w_1 - w_8 . The appropriate set of weights may be selected after analyzing the interference environment.

[0150] FIG. 17 is a diagram illustrating another embodiment of an interference canceller 1700 that is built according to the present invention. The FIG. 17 may be viewed as being somewhat similar to the interference canceller 1600 of the FIG. 16 with some exceptions relating to the specific codes that are used to perform the linear combination in an effort to perform the interference cancellation according to the present invention.

[0151] The FIG. 17 shows an embodiment where all of the codes are included in the linear combiner. This includes both the used codes and the unused codes, instead of only the unused codes. This will be useful if there is inter-code interference (ICI), since in that case the desired signal will appear on all codes. Conversely, the signals modulated onto all codes will appear on the desired de-spreader output, and can be subtracted from the desired de-spreader output.

[0152] In yet another alternative embodiment, to add to the number of effective unused codes, we may use codes bearing preamble symbols in addition to the codes carrying zero-valued symbols. The preamble symbols are known and can be subtracted once their amplitude and phase have been measured, for example using a preamble correlator. Thus the preamble-bearing codes can also be used as inputs to the linear combiner in order to better cancel the interference.

[0153] There are some other embodiments that may be employed as well. For example, the selection of the inactive codes may be performed as follows: (1) use codes 0, 1, 2, 3, . . . (adjacent codes, as done in DOCSIS 2.0 spec) in which the codes are adjacent and the lower codes used in the coding and/or (2) spacing the codes maximally apart. For example, using DOCSIS 2.0 S-CDMA code set, the 8 unused codes out of 128 total codes might be code numbers {15 31 47 63 79 95 111 127} when seeking to perform the maximally spaced apart embodiment. Moreover, the selection of the unused codes may be performed according to an optimality criterion. Examples of some potential optimality criteria include: (1) select unused codes that have maximal correlation with the interference, (2) minimize enhancement of white noise resulting from cancellation process, and (3) minimize residual interference power after cancellation.

[0154] It is also noted that the particular codes that are selected as the unused codes may change over time during the processing of received signals. Moreover, the particular selection of the codes may vary from one iteration to the next. For example, in one situation, adjacent codes may be selected as the unused codes. In another situation, the maximally spaced codes may be selected as the unused codes.

[0155] The selection of the codes that are to be designated the unused codes may be performed using a variety of approaches including: (1) employing code matrix reordering,

(2) employing null grant periods, (2) zero padding data, and/or (4) employing some optimality criterion (or criteria).

[0156] Similar to the embodiment of the FIG. 16, it is also noted that the weight computation functionality may be performed offline, and these pre-computed complex-valued combining weights that are used here in the FIG. 17 may similarly be stored in memory and/or a look up table (LUT) that may be used to provide the complex-valued combining weights. The appropriate set of weights may be selected after analyzing the interference environment. This may similarly be performed in the embodiments of the FIGS. 18 and 19 described in further detail below where these pre-computed complex-valued combining weights may also be stored in memory and/or a look up table (LUT).

[0157] FIG. 18 is a diagram illustrating another embodiment of an interference canceller 1800 that is built according to the present invention. The FIG. 18 may be viewed as being a variant of the FIG. 17 that has access to any of the codes (including both used and unused codes). The FIG. 18 includes a subset of the codes for use in the linear combiner, instead of all the codes or only the unused codes. For example, in DOCSIS 2.0 S-CDMA, adjacent codes are nearly shifts of each other. When a timing offset occurs, the codes lose orthogonality and ICI occurs. However, the ICI is predominant on the adjacent codes. For example, in the presence of a timing offset, code 35 will be interfered with predominantly by codes 34 and 36, with lesser effects coming from codes 33 and 37, even lesser effects from codes 32 and 38, and so on. Hence including as inputs to the linear combiner the data-bearing codes 33, 34, 36 and 37, plus the unused codes, but not the remaining data-bearing codes, will reduce the number of weights that have to be solved for compared to the more general case above in which all codes are included in the linear combination. Another embodiment would involve including as inputs to the linear combiner the data-bearing codes 34, and 36, plus the unused codes, but not the remaining data-bearing codes, in an effort to try to reduce the number of weights that have to be solved for compared to the more general case above in which all codes are included in the linear combination.

[0158] FIG. 19 is a diagram illustrating an embodiment of an interference canceller with memory 1900 that is built according to the present invention. The FIG. 19 shows an interference canceller with memory, that is, it uses the history of previous samples in computing the output. The weight w_1 has been replaced with "feed-forward equalizer 1" (FF Eqr. 1), a tapped delay line or FIR filter with L weights. The other adaptive weights have similarly been replaced with FF equalizers 2-8. It is noted that both the current and past soft de-spread symbols are included in the linear combination. Moreover, future soft de-spread symbols may also be included in the linear combination; these future soft de-spread symbols are "future" relative to the symbol currently being estimated. This permits each tap to have a frequency selective response.

[0159] FIG. 20 is a diagram illustrating an embodiment of equalization with canceller 2000 that is arranged according to the present invention. The FIG. 20 may be viewed as being a representation of equalization of channel response, and cancellation of resulting colored noise. The canceller structure can also be used to help with equalization. The FIG. 20 considers a communications system with a transmitter 2010, a channel 2020 having a response $H(f)$, and a receiver 2025. Let the channel response be $H(f)$. We assume, as an example, that $H(f)$ exhibits a null at some frequency in the signaling band of

interest. Assume AWGN (additive white Gaussian noise) is added in the channel after $H(f)$. We may use a standard adaptive equalizer 2030 at the receiver to provide the inverse (zero forcing) response, $1/H(f)$, which will have a narrow peak at the frequency location where the null exists in $H(f)$. This peak will cause the white noise to be colored and to have a peak as well. This narrowband colored noise can be canceled (using the canceller 2040) by the present technique in exactly the same manner that other narrowband interference is canceled. The FIG. 20 shows yet another embodiment of how interference cancellation, according to the present invention, may be performed.

[0160] FIG. 21 is a diagram illustrating an embodiment of Least Means Square (LMS) training of an interference canceller 2100 according to the present invention. The FIG. 21 may be viewed as being one embodiment that is operable to perform adaptation of an interference canceller using iterative methods. The present interference canceller 2100 can be adapted using iterative methods such as LMS or RLS. The FIG. 21 illustrates how the LMS method may be used to adapt the canceller weights. The output of the de-spreader for the desired code (containing soft decisions) is sliced to produce hard symbol decisions. If known training symbols are available, they replace the hard decisions, which may contain symbol errors, especially upon startup. The difference between the hard (or known) and soft decisions gives the LMS error sample. The error is correlated with the outputs of the unused code de-spreaders and used to update the adaptive weights w_i .

[0161] Within the FIG. 21, the slicer, the MUX, and the LMS error (and LMS step-size scaling μ) that are used to update the adaptive weights w_i may be viewed as being just one embodiment of an iterative, error determining approach. Clearly, other error determining approaches (besides LMS) may be employed without departing from the scope and spirit of the invention. The error calculation and correlation with the outputs of the unused code de-spreaders that are used to update the adaptive weights w_i may be viewed as being an iterative adaptive weight functionality that may be viewed as being provided in an implementation via an iterative adaptive weight functional block that communicatively couples to each of the outputs of the unused code de-spreaders.

[0162] FIG. 22A is a diagram illustrating an embodiment of signal transformation according to the present invention. The FIG. 22A includes the pre-processing of an input signal, and unused inputs, via an orthogonal transformation 2210 to generate a representation of the input signal within a finite signal space. The orthogonal transformation 2210 may be an orthonormal transformation in certain embodiments. Now that the input signal is represented in the finite signal space, the signal is then passed through a communication channel 2230 after which it is provided to an interference cancellation functional block 2220 that is operable to perform any of the various embodiments of interference cancellation described herein. The communication channel 2230 may introduce interference. It is noted that the present invention is operable to perform cancellation of interference of a variety of types including (1) narrowband interference in general, (2) Ham radio, CB radio and HF radio, (3) adjacent channel interference (spillover from desired signals in neighboring channels), (4) CDMA on a small number of codes, and (5) impulse/burst noise. The present invention envisions any orthogonal transformation 2210 that is operable to transform an input signal into a representation of a finite number of elements within a

finite signal space so as to facilitate the interference cancellation according to the present invention.

[0163] FIG. 22B is a diagram illustrating another embodiment of signal transformation according to the present invention. The FIG. 22B includes the pre-processing of an input signal, and unused inputs, via an identity matrix transformation 2215 to generate a representation of the input signal within a finite signal space. Again, the orthogonal transformation 2215 may be an orthonormal transformation in certain embodiments. Now that the input signal is represented in the finite signal space, the signal is then passed through a communication channel 2235 after which it is provided to an interference cancellation functional block 2225 that is operable to perform any of the various embodiments of interference cancellation described herein. The communication channel 2235 may introduce interference. It is again noted that the present invention is operable to perform cancellation of interference of a variety of types including (1) narrowband interference in general, (2) Ham radio, CB radio and HF radio, (3) adjacent channel interference (spillover from desired signals in neighboring channels), (4) CDMA on a small number of codes, and (5) impulse/burst noise. Further details are described below with respect to impulse noise cancellation.

[0164] Impulse noise is nearly zero most of the time, and large during a few samples. For the purpose of analysis only, we consider the rows of the $N \times N$ identity matrix as the basis set, where N is the number of samples per frame (or chips per spreading interval) under consideration. In this basis set, each time sample represents one dimension. Hence we see that the impulse noise only occupies a small number of dimensions. Thus it can be canceled by this technique, using an arbitrary basis set, such as the S-CDMA codes. The adapted de-spreading code has zeros (or nearly zeros) at the chips corresponding to the time location of the impulse noise. However, impulse noise occurs at a random, unpredictable location in each frame. If we know where it is, we can solve the equations for the weights. But the next frame it will be in a different place. This means re-doing the computations every frame, resulting in high complexity.

[0165] For low-level impulse noise, it may be difficult to locate the chips that are affected by impulse noise. We may use one or more "indicator codes" for this purpose, as follows. As an example, say we have 128 total codes—for example in the DOCSIS 2.0 situation. We designate 119 of these codes as used, or data-carrying codes. We designate 9 of the codes as unused codes, on which numerically-zero-valued symbols are transmitted. Of these 9 unused codes, 8 codes participate in the linear combiner for noise cancellation, and there is 1 extra or "indicator" code. The indicator code is de-spread as if it were a used code, that is, it is given the benefit of the linear combiner canceller. We expect to get a zero symbol at its de-spreader output; if we see noise instead of zero that provides an indication of the amount of noise that has not been canceled. We then proceed as follows to locate the impulse noise. Assume for example that there is one occurrence of impulse noise in a given symbol, and that the impulse noise affects 8 or fewer chips. We begin with a set of weights w that null chips 1 through 8 in the time domain. We use w to de-spread the indicator code, and observe the output y . We then modify w to null chips 2-9, and again observe y . In a similar manner, we scan w across the entire symbol, measuring y at each time offset. We believe that the power $|y|^2$ will exhibit a minimum for the weight set w that corresponds to

the time location of the impulse noise. In this manner the location of the impulse noise can be determined. Once located, it can be canceled.

[0166] FIG. 23 is an operational flow diagram illustrating an embodiment of an interference cancellation method 2300 that is performed according to the present invention. In a block 2310, a spread signal is received that contains interference. Then, the received spread signal is de-spread into a number of codes in a block 2320. Each of the codes is selectively processed using linear combination processing as shown in a block 2330. There are a variety of ways in which the linear combination processing may be performed according to the present invention including using a number of unused codes, using all of the available codes, and/or using selected adjacent codes in addition to the unused codes. Ultimately, the interference cancelled de-spread codes are output as shown in a block 2340.

[0167] FIG. 24 is an operational flow diagram illustrating another embodiment of an interference cancellation method 2400 that is performed according to the present invention. Initially, in some embodiments, the method involves selecting those codes that are to be used as the unused codes as shown in a block 2402. As shown within the FIG. 24, there are three different ways in which this may be performed. They include code matrix reordering, employing null grant periods, and/or zero padding data. Even other ways are described when referring to the other Figures as well. These will be the codes that are used to perform the linear combining to effectuate the interference cancellation according to the present invention. In even other embodiments as shown in a block 2404, the unused codes (N_u) are modulated with numerically zero-valued symbols. Alternatively, the unused codes (N_u) may be modulated with numerically constant-valued symbols that are non-zero without departing from the scope and spirit of the invention.

[0168] In a block 2410, a spread signal is received that contains interference. Then, the received spread signal is de-spread into a number of codes (N_c) as shown in a block 2420. In a block 2430, each of the number of unused codes (N_u) is selectively de-spread. The method then will continue to the block 2440 in most instances.

[0169] However, in certain embodiments, the method will continue from the block 2430 to the block 2432 in which each of the number of preamble codes is selectively de-spread. The preamble symbols are known and can be subtracted once their amplitude and phase have been measured, as shown in a block 2434, for example using a preamble correlator. Thus the preamble-bearing codes can also be used as inputs to the linear combiner in order to better cancel the interference.

[0170] As shown in the block 2440, complex-valued weights for linear combination processing of the unused codes (N_u) are selectively calculated. This processing in the block 2440 may be performed by inputting the spread signal, interference, and/or outputs as shown in a block 2442. In the embodiments where the blocks 2432 and 2434 are performed, the preamble-bearing codes may be input as shown in a block 2444 when performing the processing in the block 2440. The processing in the block 2440 may be performed by employing LMS processing as shown in a block 2446 and/or LS processing as shown in a block 2448.

[0171] Then, in a block 2450, the complex value weights are selectively applied to scale the unused codes (N_u). In a block 2460, the now scaled unused codes (N_u) are selectively

summed with the desired code. Ultimately, the interference cancelled de-spread codes are output as shown in a block **2440**.

[0172] FIG. 25 is an operational flow diagram illustrating an embodiment of an unused code selection method **2500** that is performed according to the present invention. The question arises whether any subset of the codes is a good choice for the unused codes. We consider the example of narrowband interference cancellation in a DOCSIS 2.0 S-CDMA system. For efficient narrowband interference canceling capability, the unused codes have to be chosen such that it is possible to combine them in the adapted codes (in the linear combiner) to form one or more notches in the frequency domain. Thus, for optimal performance, one might need to designate specific codes as unused. The current DOCSIS 2.0 draft specification does not permit the selection of which codes are unused. It has been found that successive, or “adjacent”, DOCSIS 2.0 codes are not a good choice. This is because each code is approximately a shift of the previous code. This implies that adjacent or nearly adjacent codes have nearly the same frequency response. Some techniques that could be used to “force” unused codes at specific rows of the code matrix are the following:

[0173] The code matrix may be reordered. In this technique, both the CM and CMTS re-order the code matrix as shown in a block **2510**, prior to spreading or de-spreading. This may be performed such that desired unused codes are grouped together (say at the lower part of the rearranged code matrix) as shown in a block **2520**. Similarly, the desired used codes should be grouped as well (say at the upper part of the rearranged code matrix) as shown in a block **2530**. Using such technique requires the knowledge of the reordering pattern at the CMTS as well as all CMs; this may be ensured as shown in a block **2540**.

[0174] Alternatively, the selection of unused codes may be performed using null grant periods. In this technique, the CMTS instructs all CMs to be silent during a specific grant as shown in a block **2505** (i.e., the desired unused codes). This technique has the advantage that the CMs need not have prior knowledge of the unused codes and just follow the CMTS grants. However, it may be viewed as causing inefficiencies to the CMTS scheduling process that may prohibit this approach in some implementations.

[0175] Alternatively, the selection of unused codes may be performed by zero-padding the data. In this technique, the CMTS grants the CM a longer grant period that what is needed to transmit the grant data as shown in a block **2555**. If desired when performing the operation of the block **2555**, the grant sizes are chosen by the CMTS in a way such that the CM zero-padding occurs at the desired unused codes as shown in a block **2557**. The CMTS also instructs the CM to append the transmitted data with zero-symbols as shown in a block **2565**.

[0176] FIG. 26 is an operational flow diagram illustrating an embodiment of an S-CDMA interference cancellation method **2600** that is performed according to the present invention. In a block **2610**, a set of used codes is selected. Then, in a block **2620**, a set of unused codes is selected. A signal is transmitted using the used codes as shown in a block **2630**. In certain embodiments, as shown in a block **2632**, we transmit one or more zeroes on the inactive/unused codes. Alternatively, as shown in a block **2634**, we transmit a known sequence (training or pilot symbols) on the inactive/unused codes. Alternatively, we may transmit lower order modulation on “inactive” codes.

[0177] Then, in a block **2640**, the received signal is processed using the received signal’s projection on the active (used) codes and the inactive (unused) codes thereby canceling interference. We process the received signal using both its projection onto a desired (active) code, and its projection onto the inactive codes, in order to cancel interference on the desired code. From certain perspectives, in the context of a system and method that employ vector de-spreading to a spread signal, the projection may be viewed as being the vector de-spreader output. However, in other contexts, a projection may be viewed as being the representation of the received signal across its finite signal space. This understanding of projection may be used to describe the representation of the signal across a finite signal space.

[0178] The FIG. 26 is performed within the context of an S-CDMA communications system in the presence of interference. There are a number of types of S-CDMA systems that may support the method of the FIG. 26. For example, some types of S-CDMA systems include DOCSIS 2.0 set of codes and Walsh-Hadamard codes. The selection of the inactive/unused codes may be performed as illustrated and described above within some of the embodiments shown in a block **2621** including use codes 0, 1, 2, 3, . . . (adjacent codes, as done in DOCSIS 2.0 spec), spacing the inactive/unused codes maximally apart as shown in a block **2622**, and selecting the codes according to an optimality criterion as shown in a block **2623**.

[0179] For example, when spacing the inactive/unused codes maximally apart within DOCSIS 2.0 S-CDMA code set, the 8 unused codes out of 128 total codes might be code numbers {15 31 47 63 79 95 111 127}. When selecting a different number of unused codes within the DOCSIS 2.0 S-CDMA code set, they may be similarly maximally spaced apart.

[0180] In addition, the inactive/unused codes may be selected according to the optimality criterion of the block **2623**. Examples of an optimality criteria would be to select unused codes include: (1) selecting inactive/unused codes that have maximal correlation with the interference as shown in a block **2624**, (2) minimizing enhancement of white noise resulting from cancellation process as shown in a block **2625**, and (3) minimizing residual interference power after cancellation as shown in a block **2626**.

[0181] FIG. 27 is an operational flow diagram illustrating another embodiment of an interference cancellation method **2700** that is performed according to the present invention. In a block **2710**, a set of active/used basis waveforms is selected. These basis waveforms may include orthogonal (or nearly orthogonal) waveforms; these waveforms may be viewed as being substantially orthogonal. There are a number of types of sets of orthogonal waveforms may be employed. Some specific examples of sets of orthogonal waveforms include: (1) S-CDMA codes, including DOCSIS 2.0 and Walsh-Hadamard, (2) an orthogonal set of binary spreading codes, (3) any orthogonal set of quaternary spreading codes, and (4) the rows of the identity matrix.

[0182] Then, in a block **2720**, a set of inactive/unused basis waveforms is selected. In certain embodiments as shown in a block **2722**, we may assume that the number of inactive/unused basis waveforms is less than number of active/used basis waveforms. A signal is transmitted using the active/used basis waveforms as shown in a block **2730**. In certain embodiments, as shown in a block **2732**, we transmit one or more zero valued symbols on the inactive/unused basis waveforms.

Alternatively, as shown in a block **2734**, we transmit a known sequence (training or pilot symbols) on the inactive/unused basis waveforms.

[0183] Then, in a block **2740**, the received signal is processed using the received signal's projection on the active (used) basis waveforms and the inactive (unused) basis waveforms thereby canceling interference. We process the received signal using both its projection onto a desired (active) waveform, and its projection onto the inactive waveforms, in order to cancel interference on the desired waveform.

[0184] Alternatively, in a block **2742**, the received signal is processed using the received signal's projection on the active (used) basis waveforms thereby canceling interference. We process the received signal using its projection onto a desired (active) waveform in order to cancel interference on the desired waveform.

[0185] In even alternative embodiments, in a block **2744**, we compute the projection of the interference on the inactive/unused basis waveforms, and subtract it from the projection on the active/used basis waveforms of the received signal including interference thereby canceling interference. It is noted here that we can reduce the computational complexity by computing the null-space projection (the projection of the interference on the inactive basis waveforms) and subtracting it from the overall projection (the projection of the signal+interference on the active basis waveforms). As an example, if we have 120 active codes and 8 inactive codes, in the present method we only need to invert an 8×8 matrix. In the standard least-squares approach, we would have to invert a 120×120 matrix.

[0186] The selection of the inactive/unused basis waveforms may be performed as illustrated and described above within some of the embodiments selecting adjacent basis waveforms, spacing the inactive/unused basis waveforms maximally apart, and selecting the basis waveforms according to an optimality criterion. Examples of an optimality criteria would be to select unused basis waveforms include: (1) selecting inactive/unused basis waveforms that have maximal correlation with the interference, (2) minimizing enhancement of white noise resulting from cancellation process, and (3) minimizing residual interference power after cancellation. These parameters that may be used to perform the selection of the inactive/unused basis waveforms is analogous to the selection of the inactive/unused codes that is performed above with respect to the FIG. **26**, except here, the selection is with respect to the basis waveforms of the signal space.

[0187] FIG. **28** is a diagram illustrating an embodiment of a spectrum of narrowband interference **2600** that may be addressed and overcome when practicing the present invention. The FIG. **28** shows the spectrum of narrowband interference (for example, the signal n in the FIGS. **16**, **17**, and/or **18**) that may be present at the input of a communications receiver. The desired signal is not present in this Figure. In this example, the 3-dB bandwidth of the interference is $\frac{1}{32}$ of the symbol rate of the desired signal. Its power is equal to the desired signal (0 dBc), when the desired signal is present. The SNR (Signal to Noise) of the desired signal, when present, is 35 dB in the example.

[0188] FIG. **29** is a diagram illustrating an embodiment of a spectrum of an adapted code showing a null at a location of interference **2900** that may be achieved when practicing the present invention. The FIG. **29** shows the spectrum of the

adapted code. The adapted code is seen to have a null corresponding to the narrowband interference. Hence, the adapted code cancels the narrowband interference.

[0189] FIG. **30A** is a diagram illustrating an embodiment of a received constellation before interference has been cancelled **3000** when practicing the present invention. The FIG. **30A** shows the output d_s of the vector de-spreader before interference cancellation is enabled using the linear combiner and weight computation functionality. This may be viewed as being the output d_s within any of the FIGS. **16**, **17**, and/or **18**. That is, all the adaptive weights w_i are zero, and only the normal de-spreading code c_s is used to de-spread the desired signal. We see that the signal constellation is unrecognizable due to the large amount of interference, which has not yet been canceled.

[0190] FIG. **30B** a diagram illustrating an embodiment of a received constellation after interference has been cancelled **3005** when practicing the present invention. The FIG. **30B** shows the output d_s of the de-spreader after the interference cancellation of the present invention is enabled using the linear combiner and weight computation functionality. Now the adaptive weights w_i have adapted and are nonzero, and as a result the adapted de-spreading code c_a is used to de-spread the desired signal. We see that the 64 QAM signal constellation, plus the QPSK constellation used for the preamble, is now clearly recognizable and the interference has been effectively canceled.

[0191] Another variant embodiment of the present invention may be performed by applying the linear combiner at the chip level instead of the de-spread symbol level. In this approach, the 128 chips (again using the 128 code embodiment example) used in the de-spreader for the desired code are adapted (for example, using the LMS method or LS method) until they converge to the near-optimal adapted de-spreading code. This adapted de-spreading code will be complex-valued and will be a linear combination of all 128 de-spreading codes. In this approach there are 128 adaptive complex weights that need to be trained, so convergence is slower than for the baseline approach in which, for example, only 8 weights need to be trained for the 8 unused codes.

[0192] The general applicability of the present invention across a wide variety of contexts is to be understood. The present invention is operable to cancel not only narrowband interference, but any interference that occupies a small number of dimensions in the signal space. The first example, given above, is narrowband interference. However, other types of interference may be substantially eliminated according to the present invention as well. A narrowband signal occupies a small number of DFT bins (DFT: discrete Fourier transform—one example of an orthonormal expansion) bins, showing that it occupies a small number of dimensions in signal space.

[0193] An extremely simple example is a CW (Continuous Wave) signal whose frequency is an integer multiple of the de-spread symbol rate; this CW signal occupies only a single bin in the DFT, or only one dimension in the signal space, where each dimension is, in this case, one DFT bin. Another example is a short burst of noise (impulse or burst noise). A short burst signal occupies a small number of time samples, again showing that it too occupies a small number of dimensions, where each dimension is, in this case, a time sample. Other types of signals can be constructed without limit that

satisfy the property that they occupy a small number of dimensions. All such signals can be canceled by the present technique.

[0194] Again, the DFT is just one example of an orthonormal expansion. A second example is the code matrix in DOCSIS 2.0 S-CDMA. Innumerable other orthonormal transforms exist. If a signal occupies a small number of dimensions in any orthonormal transform, the present invention's technique will help cancel it.

[0195] The present invention may also be implemented to use unused spatial dimensions to cancel interference according to the present invention. For example, we can generalize the technique to spatial dimensions as well. One such interpretation of spatial dimensions is with respect to MIMO (multi-input multi-output) systems. We may designate certain transmit antennas to transmit zeros at certain times. At the receiver, we may also utilize the samples from extra receive antennas to cancel interference.

[0196] In any of the embodiments described herein, the present invention is operable to store pre-computed weights using any number of various storage techniques, such as a look up table (LUT), memory, or some other storage technique. This may be beneficial in some cases where it may be impractical to compute the weights fast enough, so we may want to pre-compute some "canned" sets of weights. As an example, consider very wideband interference that occupies $\frac{1}{2}$ the bandwidth of the desired signal. Assuming an S-CDMA system, we will need to have 64 unused codes out of 128 total codes. Each desired code now has 64 adaptive weights that need to be solved for. This implies a very large matrix to invert, which is very complex to implement in real time. However, we note that in our favor, there are very few notches of this size (half the bandwidth) to go across the band. If, for example, we pre-compute the weights for several wideband notches and store the weight sets, then we can simply select the notch that most closely matches the interference when it occurs.

[0197] The present invention is also operable to support adjusting and tracking of pre-computed weights. As an extension to the above concept of storing pre-computed weights, we may store a single prototype set of weights, and modify the weights to move the notch around. For example, we can adjust the frequency of the notch without having to completely re-compute the weights. We can also adjust the depth of the notch. We can weight and superimpose pre-computed notches to build up a more complex notch structure. We can build a tracking loop that automatically adjusts the frequency (or other parameter) of the notch as the interference changes. Say there is narrowband interference, and we have applied a notch that cancels it. Now let the interference slew its frequency. We can implement a tracking loop that automatically slews the frequency location of the notch to track the frequency of the interference. There are many ways to implement such a tracking loop. One way is by taking an FFT of the interference, and tracking the energy in the peak corresponding to the interference. Another way is to dither the location of the notch, and measure the power or SNR at the output. We then move the notch in the direction of increasing SNR or decreasing interference or total power. Many other tracking methods can be devised.

[0198] The present invention may also be implemented to perform adjacent channel interference (ACI) cancellation when performing interference cancellation. For example, the canceller can also be used to cancel ACI. Consider a desired

signal with signals present in the upper and lower adjacent channels. If the adjacent channel signals overlap slightly with the desired-signal band, ACI results. ACI is in general colored and can therefore be canceled using the present canceller technique.

[0199] In performing the processing, the present invention may employ a sliding window. The processing has thus far been described as being done on a block basis, where a block is typically a symbol of 128 chips in the DOCSIS 2.0 implementation. However, the present invention is also operable when employing a sliding block approach as well. This may have the greatest benefit when the code matrix is the identity matrix, where no spreading occurs.

[0200] Code hopping is defined in the DOCSIS 2.0 spec as a process whereby the code matrix is modified by a cyclic rotation of the rows of the entire code matrix (except possibly the all -1's code) on each spreading interval. This causes the set of unused codes to be different on each spreading interval, requiring the re-computation of the adaptive weights in the canceller on each spreading interval. It would be better to hop over the set of codes excluding the unused codes, so that the unused codes will be the same on each spreading interval. This would obviate the need to re-computation of the adaptive weights on each spreading interval, reducing processing complexity. Or, we can just turn off code hopping when the canceller is used. However, this latter approach removes the benefits of code hopping, which include fairness (equality of average performance) for all users.

[0201] In the case of the DOCSIS 2.0 S-CDMA code matrix, the rows, or basis functions, are nearly cyclic shifts of each other, with the exception of code 0. This property relates adjacent codes to shifts in time by one chip. This in turn relates the linear combiner used on the de-spreader outputs to a FIR filter in the time domain. This implies that the adaptive weights for the unused codes are similar to the weights that are produced by the time domain interference cancellation structure used for TDMA. The latter weights can be computed efficiently by the Trench method. Hence we might use the Trench method to compute an initial set of weights for the subspace-based canceller, and iterate the weights to a more exact solution using the LMS or similar tracking method.

[0202] In addition, a decision feedback equalizer (DFE)-like structure may also be performed, as follows. The canceller begins by using the de-spreader outputs of codes 1-8 (for example) in the linear combiner to estimate the output of the code 9 de-spreader. A hard decision is made on the symbol from code 9. Now that the symbol on code 9 is available, it can be used to estimate the symbol on code 10. Once the symbol on code 10 is available, it can be used to estimate the symbol on code 11, and so on. A DFE-like structure can be constructed that can run in both directions.

[0203] As mentioned and described above, the subspace canceller can be applied to an arbitrary code matrix (basis set). One such basis set is the discrete Fourier transform (DFT). In this context one should also mention the fast DFT methods collectively referred to as the fast Fourier transform (FFT). The DFT is not well suited for narrowband interference cancellation in the receiver without modifications to the cancellation approach. This is because each basis function, the complex tone $e^{jn\omega}$ (or alternatively written as $\exp(jn\omega)$), is designed to have minimal support in the frequency domain. The basis functions cannot cancel a narrowband interferer without very large weights. Instead, locating the canceller predominantly in the transmitter is a better choice. One sim-

ply does not transmit those tones that overlap with the interference, designating them as unused “codes” or tones. This approach has been known in the industry for some time in conjunction with discrete multi-tone (DMT) or orthogonal frequency division multiplexing (OFDM) systems.

[0204] Moreover, the subspace canceller can be integrated with FEC coding. In one approach, a Reed-Solomon code can provide parity symbols that are transmitted on the unused spreading codes instead of zero symbols. In another approach, different SNRs may exist on different spreading codes (for example, when spreading code hopping is turned off). In this case unequal transmitted power may be sent on each spreading code, or unequal numbers of bits per symbol of modulation. Or, unequal coding strength can be used on each spreading code: for example, rate $\frac{7}{8}$ on one spreading code and rate $\frac{3}{4}$ on another spreading code. An important point is that these approaches will give a better result than code hopping. In code hopping, performance is averaged over all spreading codes. It is better to use our prior knowledge of which spreading codes are disadvantaged, and give them more processing power or transmit power.

[0205] The present invention is also operable, when performing interference cancellation, to perform adjustment of transmitted spectrum to meet a desired spectral mask. It may be desirable to attenuate certain portions of the spectrum using the subspace canceller. In these applications the canceller is predominantly located in the transmitter. One example is in a wireless local area network (LAN) applications. Here one has to place a notch in the transmit spectrum at the spectral location of the XM satellite radio service. The subspace canceller has a great advantage over a notch filter. A notch filter can notch out a designated spectral region, but in doing so, it distorts the desired signal. The subspace canceller can create the notch without distorting the desired signal. The subspace canceller may also have the following advantage over a notch filter. A notch filter can cause large excursions in the transmitted power, whereas the subspace canceller does not.

[0206] The interference cancellation according to the present invention may also be integrated with pre-coding. The subspace canceller can be integrated with pre-coding, such as Tomlinson-Harashima pre-coding. We note that the subspace canceller can be used for narrowband interference cancellation and also for equalization of a deep notch in the channel. These are two applications of pre-coding. Hence, if subspace cancellation and pre-coding were combined, would we get some of the advantages of both.

[0207] In view of the above detailed description of the invention and associated drawings, other modifications and variations will now become apparent. It should also be apparent that such other modifications and variations may be effected without departing from the spirit and scope of the invention.

What is claimed is:

1. An apparatus, comprising:

an equalizer that is operable to:

receive a signal from a communication channel, wherein the signal includes additive white noise and a frequency response of the communication channel includes a null at a frequency; and

equalize the signal using an inverse, zero forcing response that includes a peak at approximately the frequency of the null within the frequency response of the communication channel thereby transforming

white noise within the signal to become colored noise located at approximately the frequency; and

a canceller that is operable to perform interference cancellation on the colored noise located at approximately the frequency.

2. The apparatus of claim 1, wherein:

the signal received from the communication channel is a spread signal;

the canceller includes a vector de-spreader, a weight computation block, and a linear combiner;

the vector de-spreader is operable to employ a first plurality of codes and a second plurality of codes to de-spread the spread signal that is received from the equalizer;

the weight computation block is operable to determine a plurality of complex-valued combining weights using at least one portion of the de-spread signal and the colored noise located at approximately the frequency; and

the linear combiner is operable to:

scale a plurality of de-spread signal portions, that is de-spread using the first plurality of codes, using the plurality of complex-valued combining weights; and combine the scaled, plurality of de-spread signal portions with one signal portion that is de-spread using one code of the second plurality of codes thereby performing the interference cancellation on the colored noise located at approximately the frequency.

3. The apparatus of claim 2, wherein:

the weight computation block is operable to calculate one complex-valued combining weight of the plurality of complex-valued combining weights using the one signal portion that is de-spread using one code of the second plurality of codes and adjacent signal portions that are de-spread using codes adjacent to the one code of the second plurality of codes.

4. The apparatus of claim 2, wherein:

the weight computation block is operable to calculate one complex-valued combining weight of the plurality of complex-valued combining weights using the plurality of de-spread signal portions, that is de-spread using the first plurality of codes, and at least one additional plurality of de-spread signal portions, that is de-spread using the second plurality of codes.

5. The apparatus of claim 2, wherein:

at least one complex-valued combining weight of the plurality of complex-valued combining weights is a predetermined complex-valued combining weight.

6. The apparatus of claim 1, wherein:

the signal received from the communication channel is a spread signal;

the canceller includes a vector de-spreader;

the vector de-spreader is operable to employ a first plurality of codes and a second plurality of codes to de-spread the spread signal that is received from the equalizer; and

of first de-spread signal portions that are de-spread using the first plurality of codes and second de-spread signal portions that are de-spread using the second plurality of codes, only the first de-spread signal portions that are de-spread using the first plurality of codes are employed by the canceller to perform interference cancellation on the colored noise located at approximately the frequency.

7. The apparatus of claim 1, wherein:

the canceller includes a vector de-spreader and a plurality of feed-forward equalizers;

the vector de-spreader is operable to employ a first plurality of codes and a second plurality of codes to de-spread the spread signal that is received from the equalizer;
 each feed-forward equalizer of the plurality of feed-forward equalizers includes a tapped delay line and a plurality of combining weights;
 each feed-forward equalizer of the plurality of feed-forward equalizers is operable to sum its corresponding de-spread signal portion with delayed and scaled versions of its corresponding de-spread signal portion using the tapped delay line and the plurality of combining weights;

the linear combiner is operable to sum outputs from each feed-forward equalizer of the plurality of feed-forward equalizers and the one signal portion that is de-spread using one code of the second plurality of codes;

the plurality of feed-forward equalizers includes a first number of feed-forward equalizers;

the first plurality of codes and the second plurality of codes together include a second number of codes; and
 the first number is less than the second number.

8. The apparatus of claim 1, wherein:

the canceller includes a plurality of feed-forward equalizers;

each feed-forward equalizer of the plurality of feed-forward equalizers includes a corresponding plurality of equalizer taps; and

each equalizer tap within each corresponding plurality of equalizer taps has a frequency selective response.

9. The apparatus of claim 1, wherein:

the apparatus is operable to be implemented within an S-CDMA (Synchronous Code Division Multiple Access) communication system.

10. The apparatus of claim 1, wherein:

the apparatus is operable to be implemented within a cellular communication system that employs at least one type of S-CDMA (Synchronous Code Division Multiple Access) communications.

11. An apparatus, comprising:

an equalizer that is operable to:

receive a spread signal from a communication channel, wherein the spread signal includes additive white noise and a frequency response of the communication channel includes a null at a frequency; and

equalize the signal using an inverse, zero forcing response that includes a peak at approximately the frequency of the null within the frequency response of the communication channel thereby transforming white noise within the signal to become colored noise located at approximately the frequency; and

a canceller, that includes a vector de-spreader, a weight computation block, and a linear combiner, that is operable to perform interference cancellation on the colored noise located at approximately the frequency; and
 wherein:

the vector de-spreader is operable to employ a first plurality of codes and a second plurality of codes to de-spread the spread signal that is received from the equalizer thereby generating a first plurality of de-spread signal portions and a second plurality of de-spread signal portions;

the weight computation block is operable to determine a plurality of complex-valued combining weights using at least one portion of the de-spread signal and the colored noise located at approximately the frequency; and

the linear combiner is operable to:

scale the first plurality of de-spread signal portions using the plurality of complex-valued combining weights; and

combine the scaled, plurality of de-spread signal portions with one signal portion that is de-spread using one code of the second plurality of codes thereby performing the interference cancellation on the one signal portion that is de-spread using one code of the second plurality of codes that corresponds to the colored noise located at approximately the frequency; and

the apparatus is operable to be implemented within an S-CDMA (Synchronous Code Division Multiple Access) communication system.

12. The apparatus of claim 11, wherein:

the weight computation block is operable to calculate one complex-valued combining weight of the plurality of complex-valued combining weights using the one signal portion that is de-spread using one code of the second plurality of codes and adjacent signal portions that are de-spread using codes adjacent to the one code of the second plurality of codes.

13. The apparatus of claim 11, wherein:

at least one complex-valued combining weight of the plurality of complex-valued combining weights is a predetermined complex-valued combining weight.

14. The apparatus of claim 11, wherein:

of the first de-spread signal portions and the second de-spread signal portions, only the first de-spread signal portions are employed by the canceller to perform interference cancellation on the colored noise located at approximately the frequency.

15. The apparatus of claim 11, wherein:

a plurality of numerically values symbols is modulated using the first plurality of codes by at least one additional apparatus when generating the spread the signal; and
 the spread signal is launched into the communication channel by the at least one additional apparatus.

16. The apparatus of claim 11, wherein:

the linear combiner includes a plurality of feed-forward equalizers;

each feed-forward equalizer of the plurality of feed-forward equalizers includes a corresponding plurality of equalizer taps; and

each equalizer tap within each corresponding plurality of equalizer taps has a frequency selective response.

17. A method, comprising:

receiving a spread signal from an S-CDMA (Synchronous Code Division Multiple Access) communication channel, wherein the spread signal includes additive white noise and a frequency response of the communication channel includes a null at a frequency;

equalizing the signal using an inverse, zero forcing response that includes a peak at approximately the frequency of the null within the frequency response of the S-CDMA communication channel thereby transforming white noise within the signal to become colored noise located at approximately the frequency; and

performing interference cancellation on the colored noise located at approximately the frequency.

18. The method of claim 17, further comprising:

employing a first plurality of codes and a second plurality of codes to de-spread the spread signal;

determining a plurality of complex-valued combining weights using at least one portion of the de-spread signal and the colored noise located at approximately the frequency;

scaling a plurality of de-spread signal portions, that is de-spread using the first plurality of codes, using the plurality of complex-valued combining weights; and

combining the scaled, plurality of de-spread signal portions with one signal portion that is de-spread using one code of the second plurality of codes thereby performing the interference cancellation on the one signal portion that is de-spread using one code of the second plurality of codes that corresponds to the colored noise located at approximately the frequency.

19. The method of claim 17, further comprising:
calculating at least one complex-valued combining weight of the plurality of complex-valued combining weights;
or

selecting at least one complex-valued combining weight of the plurality of complex-valued combining weights from a plurality of predetermined complex-valued combining weights.

20. The method of claim 17, wherein:

the method is performed within an apparatus implemented within a cellular communication system that employs S-CDMA communications.

* * * * *