

(19) World Intellectual Property
Organization
International Bureau



(43) International Publication Date
30 September 2004 (30.09.2004)

PCT

(10) International Publication Number
WO 2004/082886 A1

- (51) International Patent Classification⁷: **B23K 33/00**, B32B 3/06, 3/08, 15/08, B63B 3/20, E04C 2/292, 2/38, F16B 5/08
- (74) Agents: **LEEMING, John, Gerard** et al.; J. A. KEMP & CO., 14 South Square, Gray's Inn, London WC1R 5JJ (GB).
- (21) International Application Number: PCT/GB2004/000704
- (81) Designated States (unless otherwise indicated, for every kind of national protection available): AE, AG, AL, AM, AT, AU, AZ, BA, BB, BG, BR, BW, BY, BZ, CA, CH, CN, CO, CR, CU, CZ, DE, DK, DM, DZ, EC, EE, EG, ES, FI, GB, GD, GE, GH, GM, HR, HU, ID, IL, IN, IS, JP, KE, KG, KP, KR, KZ, LC, LK, LR, LS, LT, LU, LV, MA, MD, MG, MK, MN, MW, MX, MZ, NA, NI, NO, NZ, OM, PG, PH, PL, PT, RO, RU, SC, SD, SE, SG, SK, SL, SY, TJ, TM, TN, TR, TT, TZ, UA, UG, US, UZ, VC, VN, YU, ZA, ZM, ZW.
- (22) International Filing Date: 23 February 2004 (23.02.2004)
- (25) Filing Language: English
- (26) Publication Language: English
- (30) Priority Data: 0306198.3 18 March 2003 (18.03.2003) GB
- (84) Designated States (unless otherwise indicated, for every kind of regional protection available): ARIPO (BW, GH, GM, KE, LS, MW, MZ, SD, SL, SZ, TZ, UG, ZM, ZW), Eurasian (AM, AZ, BY, KG, KZ, MD, RU, TJ, TM), European (AT, BE, BG, CH, CY, CZ, DE, DK, EE, ES, FI, FR, GB, GR, HU, IE, IT, LU, MC, NL, PT, RO, SE, SI, SK, TR), OAPI (BF, BJ, CF, CG, CI, CM, GA, GN, GQ, GW, ML, MR, NE, SN, TD, TG).
- (71) Applicant (for all designated States except US): **INTELLIGENT ENGINEERING (BAHAMAS) LIMITED** [BS/BS]; Bahamas International Trust Building, Bank Lane, PO Box N8188, Nassau (BS).
- (71) Applicant (for MW only): **LEEMING, John, G.** [GB/GB]; 14 South Square, Gray's Inn, London WC1R 5JJ (GB).
- (72) Inventor; and
- (75) Inventor/Applicant (for US only): **KENNEDY, Stephen, J.** [CA/CA]; 42 Hampton Avenue, Ottawa, Ontario K1Y 0N2 (CA).

Published:
— with international search report

For two-letter codes and other abbreviations, refer to the "Guidance Notes on Codes and Abbreviations" appearing at the beginning of each regular issue of the PCT Gazette.

(54) Title: METHOD FOR CONNECTING BY WELDING STRUCTURAL SANDWICH PLATE MEMBERS WITH CHANNEL-SHAPED CONNECTING MEMBERS

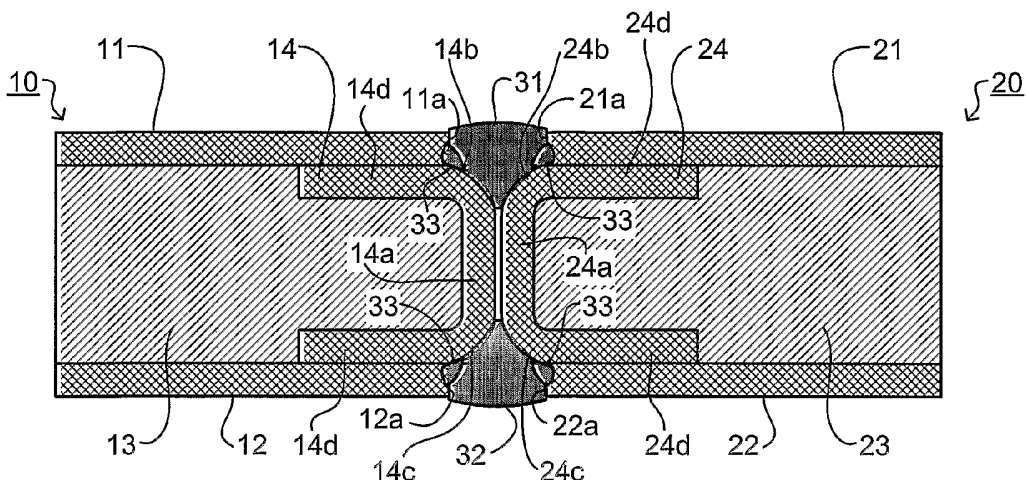

(57) Abstract: To connect two structural sandwich plate members (10, 20), each is provided with a channel-shaped connecting member (14, 24) fitted between and projecting from the outer plates (11, 12, 21, 22). The two plate members (10, 20) are abutted and welds (31, 32) formed between the outer plates (11, 12, 21, 22).

WO 2004/082886 A1

METHOD FOR CONNECTING BY WELDING STRUCTURAL SANDWICH PLATE MEMBERS WITH CHANNEL-SHAPED CONNECTING MEMBERS

5 The present invention relates to methods for connecting structural sandwich plate members which comprise two outer plates and a core of plastics or polymer material bonded to the outer plates with sufficient strength to substantially contribute to the structural strength of the member.

 Structural sandwich plate members are described in US 5,778,813 and US
10 6,050,208, which documents are hereby incorporated by reference, and comprise outer metal, e.g. steel, plates bonded together with an intermediate elastomer core, e.g. of unfoamed polyurethane. These sandwich plate systems may be used in many forms of construction to replace stiffened steel plates and greatly simplify the resultant structures, improving strength and structural performance (stiffness,
15 damping characteristics) while saving weight. Further developments of these structural sandwich plate members are described in International Patent Application WO 01/32414, also incorporated hereby by reference. As described therein, foam forms may be incorporated in the core layer to reduce weight and transverse metal sheer plates may be added to improve stiffness.

20 According to the teachings of WO 01/32414 the foam forms can be either hollow or solid. Hollow forms generate a greater weight reduction and are therefore advantageous. The forms described in that document are not confined to being made of lightweight foam material and can also be made of other materials such as wood or steel boxes.

25 International Patent Application WO 02/078948 is a further development of the concept of including hollow forms and describes forms that are easy to manufacture and assemble, in particular hollow elongate forms made from snap-together pieces are described.

 To connect together two (or more) structural sandwich plate members,
30 rolled or extruded members such as described in International Application

-2-

PCT/GB02/00157 may be used. These members accommodate a wide variety of forms of join but each different arrangement of plate members requires a different joining member. British Patent Application GB-2 380 970-A describes a universal connector in the form of a solid bar of octagonal cross-section which is welded
5 into the periphery of a structural sandwich plate member with part of the bar projecting out from between the faceplates of the structural sandwich plate member. Two (or more) plates with such connectors can be welded together in various different ways. This connector solves the problem of requiring many different members to join plate members in many different arrangements but is
10 relatively heavy.

It is an aim of the present invention to provide a method of connecting structural sandwich plate members that uses a single, lightweight connector to connect plate members together.

According to the present invention, there is provided a method of
15 connecting two structural sandwich plate members each of which comprises two outer plates and a core of plastics or polymer material bonded to the outer plates with sufficient strength to transfer shear forces therebetween, the method comprising:

providing in the edges of the structural sandwich plate members to be
20 joined channel-shaped connecting members, the connecting members fitting between, and projecting beyond the ends of the outer plates of their respective structural sandwich plate members;

placing the structural sandwich plate members together so that the edges to be joined abutt, or nearly abutt; and

25 forming a weld between the outer plates of the two structural sandwich plate members.

The connecting member is preferably channel-shaped. The convex side of the connecting member projects from between the two outer plates. When the plate members abutt, the connecting member spaces apart the outer plates of the
30 two plate members to allow a full thickness weld to be formed and acts as backing

-3-

bar for that weld.

The invention also provides a structural sandwich plate member comprising:

two outer plates;

5 a core of plastics or polymer material bonded to the outer plates with sufficient strength to substantially contribute to the structural strength of the member; and

at least one connecting member fitted between, and projecting beyond the ends of said outer plates.

10 The materials, dimensions and general properties of the outer plates of the structural sandwich plate member of the invention may be chosen as desired for the particular use to which the structural sandwich plate member is to be put and in general may be as described in US-5,778,813 and US-6,050,208. Steel or stainless steel is commonly used in thicknesses of 0.5 to 20mm and aluminium may be used
15 where light weight is desirable. Similarly, the plastics or polymer core may be any suitable material, for example an elastomer such as polyurethane, as described in US-5,778,813 and US-6,050,208.

Lightweight forms may be included in the core, as described in WO 01/32414 and WO 02/078948. It should be noted that the lightweight forms
20 serve to reduce the mass of the structural sandwich plate member and need not contribute significantly to its structural strength. The principal requirements on the lightweight forms are that they are of lower density than the plastics or polymer material forming the core and have sufficient thermal and mechanical properties to maintain the desired shape during injection and curing of the plastics
25 or polymer core. The layout of the forms within the core may be as described in British Patent Application GB-2 389 072-A filed 29 May 2002.

The present invention will be described below with reference to an exemplary embodiment and the accompanying schematic drawings, in which:

Figure 1 is a cross-sectional view of parts of two structural sandwich plate
30 members joined according to a first method of the present invention; and

-4-

Figure 2 is an enlarged part cross-sectional view of a structural sandwich plate member according to the present invention.

In the various drawings, like parts are indicated by like reference numerals.

5 Each of the structural sandwich plate members 10, 20 shown in Figure 1 comprises upper and lower outer plates (faceplates) 11, 12, 21, 22 which may be of steel and have a thickness of *e.g.* in the range of from 0.5 to 20mm. Edge plates are welded between the faceplates 11, 12, 21, 22 around their outer peripheries to form a closed cavity. In the cavity between the faceplates 11, 12, 21, 22 is a core 13, 23
10 of compact (i.e. unfoamed) plastics or polymer material, preferably a polyurethane elastomer. This core may have a thickness in the range of from 15 to 200mm. The core 13, 23 is bonded to the faceplates 11, 12, 21, 22 with sufficient strength and has sufficient mechanical properties to transfer shear forces expected in use between the two faceplates. The bond strength between the core 13, 23 and
15 faceplates 11, 12, 21, 22 should be greater than 3MPa, preferably 6MPa, and the modulus of elasticity of the core material should be greater than 250MPa. For low load applications, such as floor panels, where the typical use and occupancy loads are of the order of 1.4kPa to 7.2kPa, the bond strength may be lower, *e.g.* approximately 1MPa. By virtue of the core layer, the structural sandwich plate
20 member has a strength and load bearing capacity of a stiffened steel plate having a substantially greater plate thickness and significant additional stiffening.

To reduce the weight of the structural sandwich plate member 10, an array of lightweight forms may be provided, occupying a substantial part of the internal volume of the plate member. The lightweight forms do not need to significantly
25 contribute to the structural strength of the plate and they require only to have thermal and mechanical properties sufficient to withstand the pressure of injection of the material to form core 13 and the heat from the exothermic reaction of the core during curing.

Along an edge at which one of the structural sandwich plate members is to
30 be joined to another plate member of like type, the edge member takes the form of

-5-

a channel section 14, 24 fitting between the faceplates 11, 12, 21, 22 with its concave side facing inward. The base portions 14a, 24a and corner portions 14b, 14c, 24b, 24c project outwardly of the ends 11a, 12a, 21a, 22a of the faceplates of the two structural sandwich plate members such that when two plate members are
5 butted against each other, spaces are formed between the ends of the plate members 11a, 21a and 12a, 22a and bounded by the corner portions 14b, 24b and 14c, 24c. To join the two structural sandwich plate members 10, 20, a weld 31, 32 is formed in each of the spaces. A direct connection between the faceplates is thereby achieved quickly and simply. The corner portions 14b, c and 24b, c act as
10 weld preparation for this weld.

Figure 2 shows the position of the connecting member 14 in structural sandwich plate member 10 in more detail. As there shown, the connecting member 14 projects so that the tangents A-A, B-B to the corners 14b, 14c pass through the ends 11a, 12a of the faceplates 11, 12. This ensures that sufficient
15 space is left between the faceplates of adjacent plate members to form a substantial weld whilst the corner portions 14b, 14c form weld preparations for the weld to join the faceplates. The radius of curvature, r , of the corner portions 14b, 14c is preferably equal to twice the thickness, t , of the metal plate from which the connecting member 14 is rolled. The thickness, t , will depend on the application
20 to which the plates are to be put but will in general be comparable to the thickness of the faceplates 11, 12, e.g. 5 or 6 mm for shipbuilding applications.

The connecting member, if connected to the faceplates with sufficient strength, can contribute significantly to the strength of the plate member in the region of the join. This ensures that the plate member has sufficient strength even
25 if the heat from the weld between the faceplates damages the elastomer core. In this case the connecting member can be welded to the faceplates with one pass seal welds 33.

If, in the final structure the connecting pieces 14, 24 do not need to carry loads between the structural sandwich plate members, they can be bonded to their
30 respective plate members by the cores 13, 23. Thus, when the plate members are

-6-

made, the connectors 14, 24 can be held in place by any simple convenient method, appropriate to the method of construction of the panels. For example, if the plate members are made in a mold, the clamping force of the mold bearing on the faceplates may be sufficient to hold the connecting members in place.

- 5 Alternatively, a light adhesive, or a few spot welds may suffice. If the plate member is made using the faceplates to define the cavity for injection of the core, without a mold, the connecting members may be held in place with a ship-building adhesive or with light welds.

10 Manufacture of the plate members may be performed in situ, or off-site in factory conditions and the finished panel transported to the installation site.

It will be appreciated that the above description is not intended to be limiting and that other modifications and variations that fall within the scope of
15 the present invention, which is defined by the appended claims, are possible.

-7-

CLAIMS

1. A method of connecting two structural sandwich plate members each of
5 which comprises two outer plates and a core of plastics or polymer material
bonded to the outer plates with sufficient strength to transfer shear forces
therebetween, the method comprising:
 providing in the edges of the structural sandwich plate members to be
 joined channel-shaped connecting members, the connecting members fitting
10 between, and projecting beyond the ends of the outer plates of their respective
structural sandwich plate members;
 placing the structural sandwich plate members together so that the edges to
be joined abutt, or nearly abutt; and
 forming a weld between the outer plates of the two structural sandwich
15 plate members.
2. A method according to claim 1 wherein said connecting members are
channel-shaped.
- 20 3. A method according to claim 2 wherein in said step of providing, said
connecting members are positioned so that the tangents to the corner thereof pass
through the ends of said outer plates.
4. A method according to claim 1, 2 or 3 wherein in said step of providing,
25 said connecting members are welded to said outer plates by a one-pass seal weld.
5. A method according to claim 1, 2, 3 or 4 wherein the step of providing
connecting members is performed at a different site than the steps of placing the
structural sandwich plate members together and forming a weld.

30

-8-

6. A structural sandwich plate member comprising:
two outer plates;
a core of compact plastics or polymer material bonded to the outer plates
with sufficient strength to substantially contribute to the structural strength of the
5 member; and
at least one connecting member fitted between, and projecting beyond the
ends of said outer plates. said connecting member having surfaces adapted to be
welded to a like connecting member in a like structural sandwich plate member.
- 10 7. A structural sandwich plate member according to claim 6 wherein said
connecting member is channel-shaped.
8. A structural sandwich plate member according to claim 7 wherein tangents
to the corners of said connecting members pass through the ends of said outer
15 plates.
9. A structural sandwich plate member according to claim 6, 7 or 8 wherein
the radius of curvature of the corners of said connecting member is at least twice
the thickness of said connecting member.
20
10. A structural sandwich plate member according to claim 6, 7, 8 or 9 wherein
said connecting member is fixed to said outer plates by one-pass seal welds.
11. A structural sandwich plate member according to claim 6, 7, 8, 9 or 10
25 wherein said connecting member is formed from rolled metal.

INTERNATIONAL SEARCH REPORT

International Application No
PCT/GB2004/000704

A. CLASSIFICATION OF SUBJECT MATTER				
IPC 7	B23K33/00 E04C2/292	B32B3/06 E04C2/38		
	B32B3/08 F16B5/08	B32B15/08 B63B3/20		
According to International Patent Classification (IPC) or to both national classification and IPC				
B. FIELDS SEARCHED				
Minimum documentation searched (classification system followed by classification symbols)				
IPC 7 B23K B32B B63B E04C F16B				
Documentation searched other than minimum documentation to the extent that such documents are included in the fields searched				
Electronic data base consulted during the international search (name of data base and, where practical, search terms used)				
EPO-Internal, WPI Data, PAJ				
C. DOCUMENTS CONSIDERED TO BE RELEVANT				
Category °	Citation of document, with indication, where appropriate, of the relevant passages	Relevant to claim No.		
X,P	WO 03/101821 A (INTELLIGENT ENGINEERING B(AHAMAS) LTD; J.G. LEEMING ET AL) 11 December 2003 (2003-12-11) page 10, lines 6-25 page 11, lines 5-15; figures 9,12	1, 4-6, 10		
X,P	WO 03/033337 A (INTELLIGENT ENGINEERING (BAHAMAS) LTD ;H. MACKENZY WILSON ET AL) 24 April 2003 (2003-04-24) page 7, line 26 - page 8, line 5; claims 1,13-16; figures 1,6,8,9	1, 4-6, 10		
X	GB 2 372 476 A (INTELLIGENT ENGINEERING (BAHAMAS) LTD) 28 August 2002 (2002-08-28) cited in the application the whole document	1-11		
----- -/--				
<input checked="" type="checkbox"/> Further documents are listed in the continuation of box C. <input checked="" type="checkbox"/> Patent family members are listed in annex.				
° Special categories of cited documents :				
<table style="width: 100%; border: none;"> <tr> <td style="width: 50%; padding: 5px; vertical-align: top;"> *A* document defining the general state of the art which is not considered to be of particular relevance *E* earlier document but published on or after the international filing date *L* document which may throw doubts on priority claim(s) or which is cited to establish the publication date of another citation or other special reason (as specified) *O* document referring to an oral disclosure, use, exhibition or other means *P* document published prior to the international filing date but later than the priority date claimed </td> <td style="width: 50%; padding: 5px; vertical-align: top;"> *T* later document published after the international filing date or priority date and not in conflict with the application but cited to understand the principle or theory underlying the invention *X* document of particular relevance; the claimed invention cannot be considered novel or cannot be considered to involve an inventive step when the document is taken alone *Y* document of particular relevance; the claimed invention cannot be considered to involve an inventive step when the document is combined with one or more other such documents, such combination being obvious to a person skilled in the art. *&* document member of the same patent family </td> </tr> </table>			*A* document defining the general state of the art which is not considered to be of particular relevance *E* earlier document but published on or after the international filing date *L* document which may throw doubts on priority claim(s) or which is cited to establish the publication date of another citation or other special reason (as specified) *O* document referring to an oral disclosure, use, exhibition or other means *P* document published prior to the international filing date but later than the priority date claimed	*T* later document published after the international filing date or priority date and not in conflict with the application but cited to understand the principle or theory underlying the invention *X* document of particular relevance; the claimed invention cannot be considered novel or cannot be considered to involve an inventive step when the document is taken alone *Y* document of particular relevance; the claimed invention cannot be considered to involve an inventive step when the document is combined with one or more other such documents, such combination being obvious to a person skilled in the art. *&* document member of the same patent family
A document defining the general state of the art which is not considered to be of particular relevance *E* earlier document but published on or after the international filing date *L* document which may throw doubts on priority claim(s) or which is cited to establish the publication date of another citation or other special reason (as specified) *O* document referring to an oral disclosure, use, exhibition or other means *P* document published prior to the international filing date but later than the priority date claimed	*T* later document published after the international filing date or priority date and not in conflict with the application but cited to understand the principle or theory underlying the invention *X* document of particular relevance; the claimed invention cannot be considered novel or cannot be considered to involve an inventive step when the document is taken alone *Y* document of particular relevance; the claimed invention cannot be considered to involve an inventive step when the document is combined with one or more other such documents, such combination being obvious to a person skilled in the art. *&* document member of the same patent family			
Date of the actual completion of the international search		Date of mailing of the international search report		
26 May 2004		08/06/2004		
Name and mailing address of the ISA		Authorized officer		
European Patent Office, P.B. 5818 Patentlaan 2 NL - 2280 HV Rijswijk Tel. (+31-70) 340-2040, Tx. 31 651 epo nl, Fax: (+31-70) 340-3016		Jeggy, T		

INTERNATIONAL SEARCH REPORT

International Application No
PCT/GB2004/000704

C.(Continuation) DOCUMENTS CONSIDERED TO BE RELEVANT

Category °	Citation of document, with indication, where appropriate, of the relevant passages	Relevant to claim No.
X	US 3 235 040 A (J.T. ELLIS) 15 February 1966 (1966-02-15) column 1, lines 35-65; figures 2,3 -----	6-11
X	CH 490 588 A (SONDEREGGER EMIL) 15 May 1970 (1970-05-15) column 1, lines 22-35; claims 1-5; figure 1 -----	6-8
A	US 6 050 208 A (KENNEDY STEPHEN J) 18 April 2000 (2000-04-18) cited in the application the whole document -----	1-11

INTERNATIONAL SEARCH REPORT

Information on patent family members

International Application No
PCT/GB2004/000704

Patent document cited in search report	Publication date	Publication date	Patent family member(s)	Publication date
WO 03101821	A	11-12-2003	GB 2389081 A	03-12-2003
			WO 03101821 A1	11-12-2003
WO 03033337	A	24-04-2003	GB 2380970 A	23-04-2003
			WO 03033337 A1	24-04-2003
GB 2372476	A	28-08-2002	CA 2439353 A1	06-09-2002
			EP 1365911 A1	03-12-2003
			WO 02068186 A1	06-09-2002
			US 2004067373 A1	08-04-2004
US 3235040	A	15-02-1966	NONE	
CH 490588	A	15-05-1970	NONE	
US 6050208	A	18-04-2000	US 5778813 A	14-07-1998
			AU 747374 B2	16-05-2002
			AU 3723299 A	29-11-1999
			BG 64043 B1	28-11-2003
			BG 104922 A	29-06-2001
			BR 9910293 A	16-01-2001
			CA 2330275 A1	18-11-1999
			CN 1328502 T	26-12-2001
			EE 200000687 A	15-04-2002
			EP 1089875 A1	11-04-2001
			WO 9958333 A1	18-11-1999
			HR 20000759 A1	31-08-2001
			HU 0102151 A2	28-10-2001
			ID 26777 A	08-02-2001
			JP 2002514532 T	21-05-2002
			NO 20005640 A	08-11-2000
			NZ 507747 A	25-10-2002
			PL 343826 A1	10-09-2001
			RU 2220851 C2	10-01-2004
			SK 16652000 A3	11-06-2001
			TR 200003259 T2	21-03-2001
			ZA 200006263 A	30-05-2001
			AU 731893 B2	05-04-2001
			AU 4720497 A	03-06-1998
			BG 103394 A	31-01-2000
			BR 9713504 A	29-02-2000
			CA 2271731 A1	22-05-1998
			EE 9900192 A	15-12-1999
			EP 0938410 A1	01-09-1999
			WO 9821029 A1	22-05-1998
			ID 22728 A	09-12-1999
			KR 2000053202 A	25-08-2000
			NO 992318 A	13-07-1999
PL 333359 A1	06-12-1999			
TR 9901694 T2	21-03-2000			
US 2002187320 A1	12-12-2002			
US 6706406 B1	16-03-2004			
US 2001035266 A1	01-11-2001			