



US00D752737S

(12) **United States Design Patent**
Ohashi

(10) **Patent No.:** **US D752,737 S**

(45) **Date of Patent:** **** Mar. 29, 2016**

(54) **INDWELLING NEEDLE WITH SAFETY
DEVICE**

(71) Applicant: **Terumo Kabushiki Kaisha**, Shibuya-ku,
Tokyo (JP)

(72) Inventor: **Hiroataka Ohashi**, Tokyo (JP)

(73) Assignee: **Terumo Kabushiki Kaisha**, Shibuya-ku,
Tokyo (JP)

(**) Term: **14 Years**

(21) Appl. No.: **29/509,242**

(22) Filed: **Nov. 14, 2014**

Related U.S. Application Data

(63) Continuation of application No. 29/428,705, filed on
Aug. 2, 2012, now Pat. No. Des. 719,255.

(30) **Foreign Application Priority Data**

Feb. 2, 2012 (JP) 2012-002137

(51) **LOC (10) Cl.** **24-02**

(52) **U.S. Cl.**
USPC **D24/112**

(58) **Field of Classification Search**

USPC D24/112, 113, 114, 133, 186, 130, 127,
D24/108; D8/107, 307; D4/129, 138
CPC A61M 5/20; A61M 2005/3227; A61M
2005/3228; A61M 5/3232; A61M 2005/3258;
A61M 25/0631; A61M 2025/0018; A61M
25/0606; A61M 25/0693; A61M 5/3243;
A61M 2005/325

See application file for complete search history.

(56) **References Cited**

U.S. PATENT DOCUMENTS

5,000,740 A 3/1991 Ducharme et al.
5,108,374 A 4/1992 Lemieux
5,127,905 A 7/1992 Lemieux

5,704,919 A 1/1998 Kraus et al.
D417,083 S * 11/1999 Yun D4/138
6,379,332 B1 4/2002 Van Landuyt
6,676,638 B2 1/2004 Takagi et al.
6,770,059 B1 8/2004 Spinks et al.
6,972,002 B2 12/2005 Thorne
7,255,685 B2 * 8/2007 Pressly, Sr. A61M 5/3234
604/164.08
7,314,462 B2 * 1/2008 O'Reagan A61M 25/0631
604/110
7,351,225 B2 4/2008 Takagi et al.
(Continued)

FOREIGN PATENT DOCUMENTS

EP 0812602 A2 * 12/1997 A61M 25/0631
EP 1712250 A3 * 9/2007 A61M 25/0631

Primary Examiner — Sheryl Lane

Assistant Examiner — Ieisha Price

(74) *Attorney, Agent, or Firm* — Banner & Witcoff, Ltd.

(57) **CLAIM**

The ornamental design for the indwelling needle with safety
device, as shown and described.

DESCRIPTION

FIG. 1 is a front perspective view of an indwelling needle with
safety device showing my new design;
FIG. 2 is a front view thereof;
FIG. 3 is a rear view thereof;
FIG. 4 is a left side view thereof;
FIG. 5 is a right side view thereof;
FIG. 6 is a top plan view thereof;
FIG. 7 is a bottom view thereof;
FIG. 8 is a perspective view thereof with the environment
shown in extended condition;
FIG. 9 is a perspective view thereof with the environment
shown in compressed condition; and,
FIG. 10 is an alternate perspective view thereof with the
environment shown in extended condition.
The broken lines represent the portions of the design that form
no part of the claim.

1 Claim, 6 Drawing Sheets

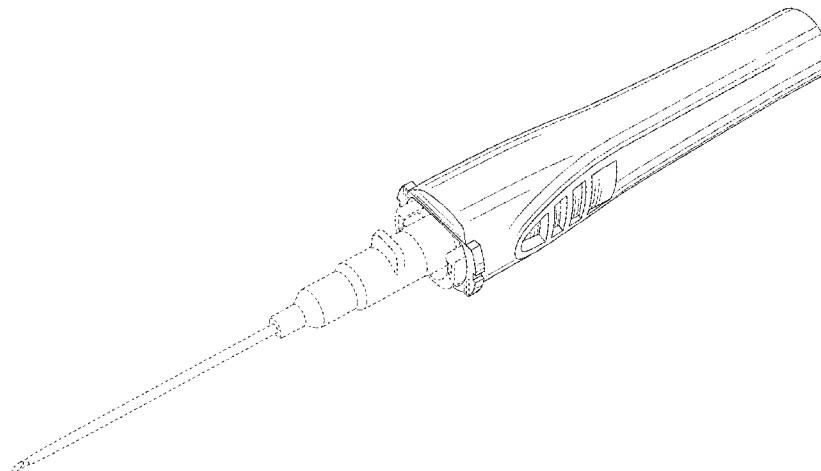

(56)

References Cited

U.S. PATENT DOCUMENTS

D603,561 S * 11/2009 Cho D28/58
 7,736,342 B2 6/2010 Abriles et al.
 D627,977 S * 11/2010 Magallanes Orozco D4/138
 D640,785 S 6/2011 Lee
 D655,406 S 3/2012 Ma et al.
 D671,815 S * 12/2012 Bauer D8/107
 D687,598 S * 8/2013 Amit D24/133
 D711,657 S * 8/2014 Chang D4/138
 D719,255 S * 12/2014 Ohashi D24/108
 D719,256 S * 12/2014 Ohashi D24/108
 2003/0199827 A1 * 10/2003 Thorne A61M 25/0631
 604/164.08

2004/0230164 A1 11/2004 Spinks et al.
 2004/0267204 A1 * 12/2004 Brustowicz A61M 25/0631
 604/168.01
 2006/0041231 A1 2/2006 Pressly et al.
 2006/0229563 A1 * 10/2006 O'Reagan A61M 25/0631
 604/164.08
 2008/0300543 A1 12/2008 Abriles et al.
 2011/0301553 A1 * 12/2011 Goral A01N 25/04
 604/265
 2011/0306933 A1 * 12/2011 Djordjevic A61M 25/0631
 604/164.08
 2013/0172820 A1 7/2013 Spearman

* cited by examiner

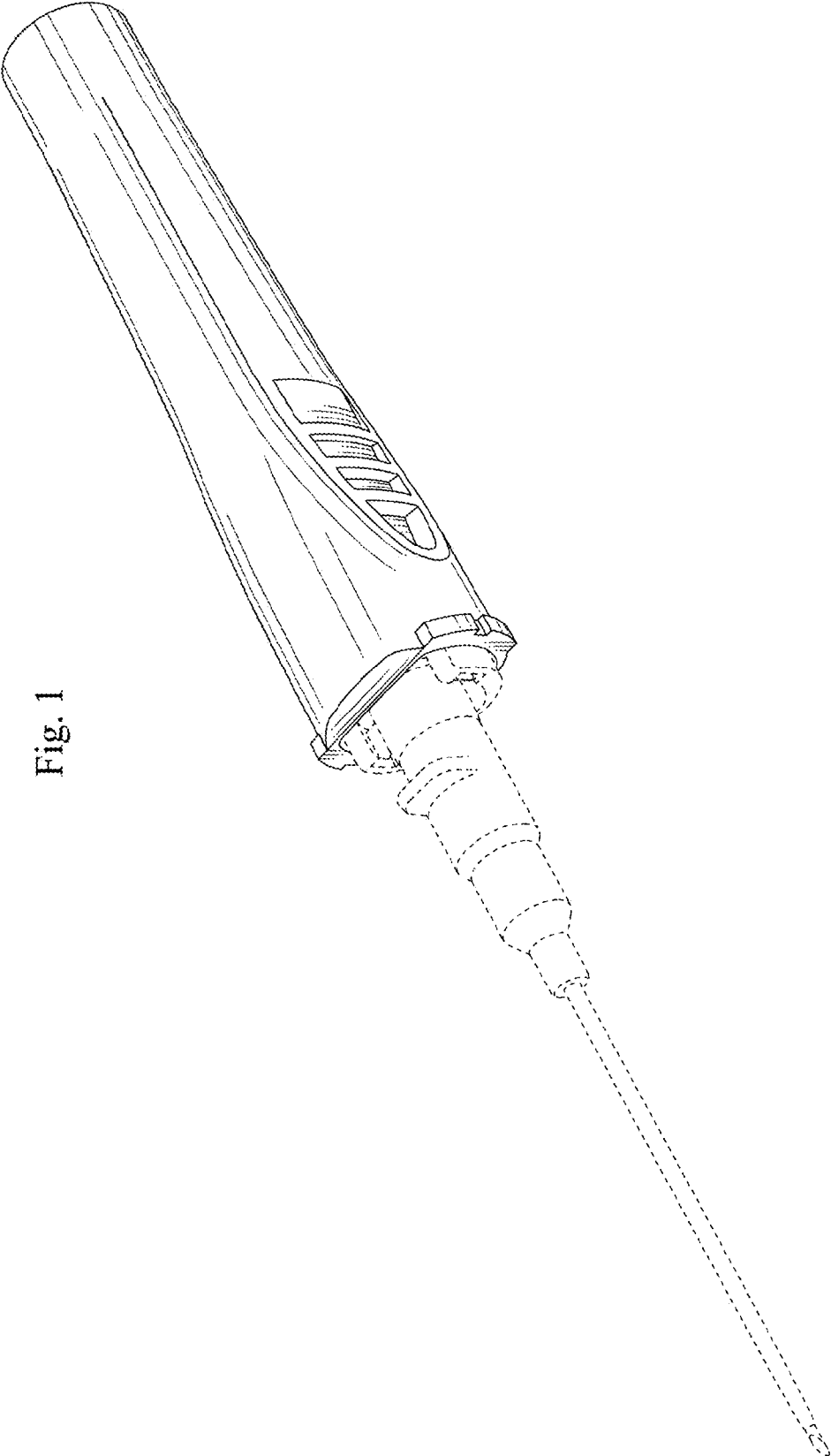

Fig. 1

Fig. 2

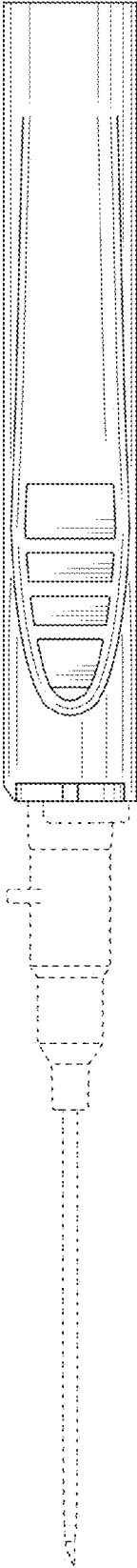

Fig. 3

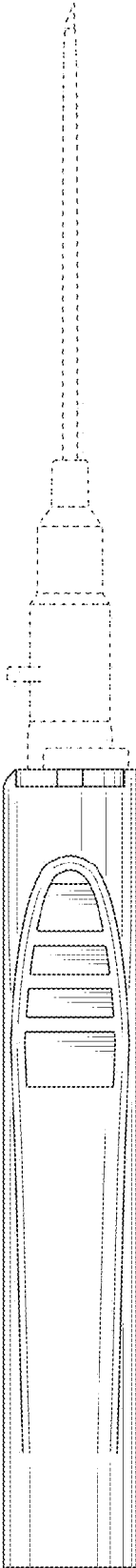

Fig. 5

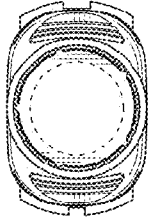

Fig. 4

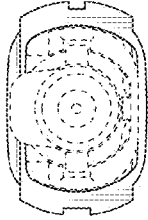

Fig. 6

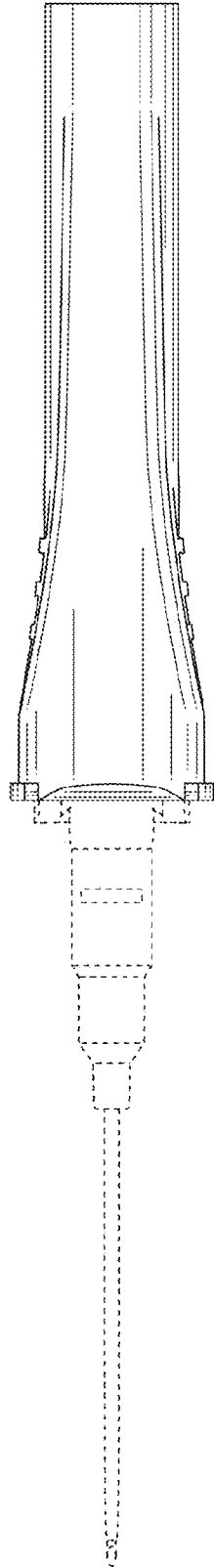
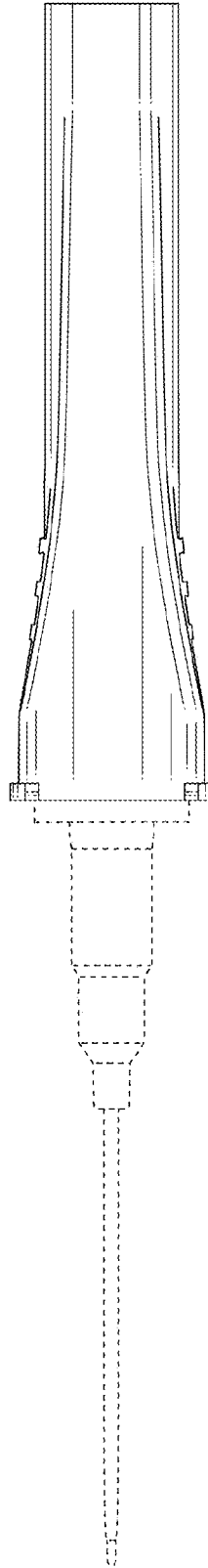

Fig. 7



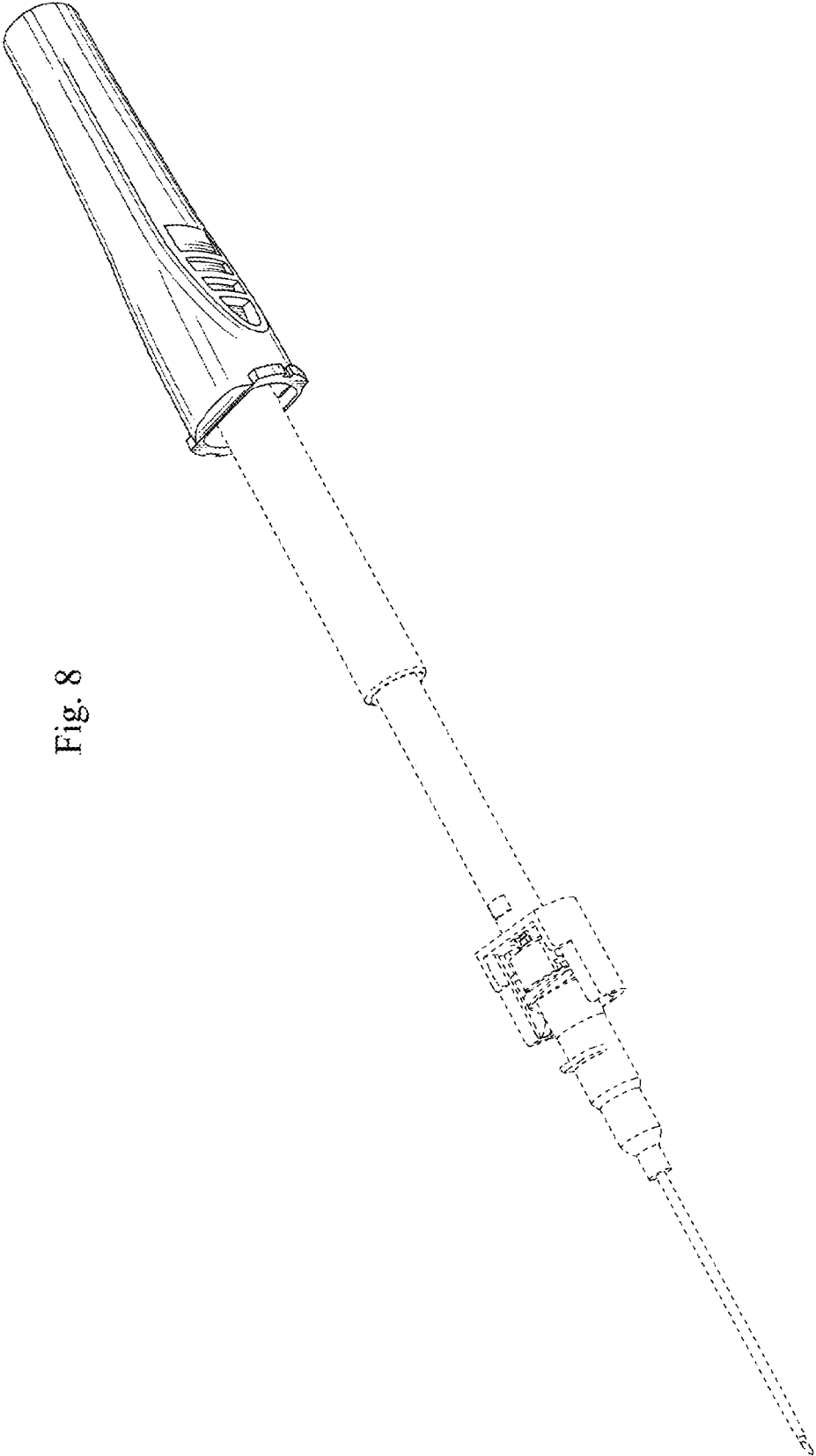
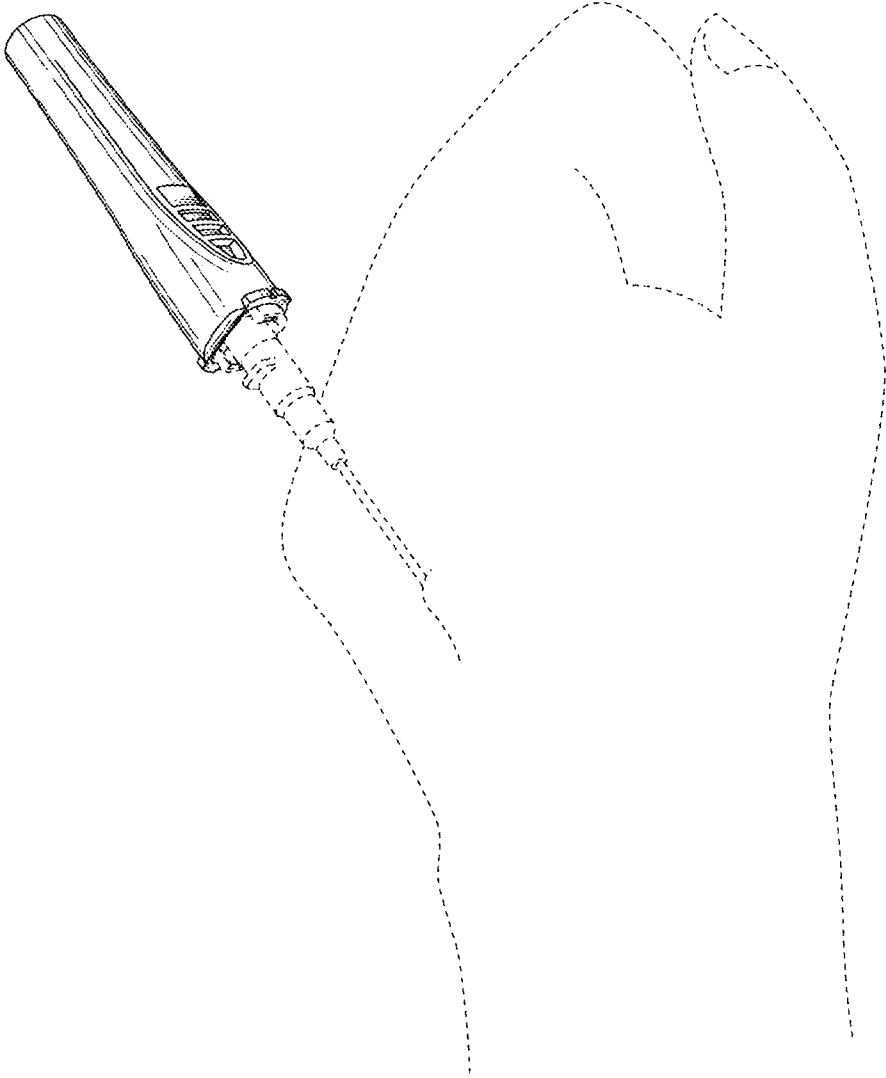

Fig. 8

Fig. 9



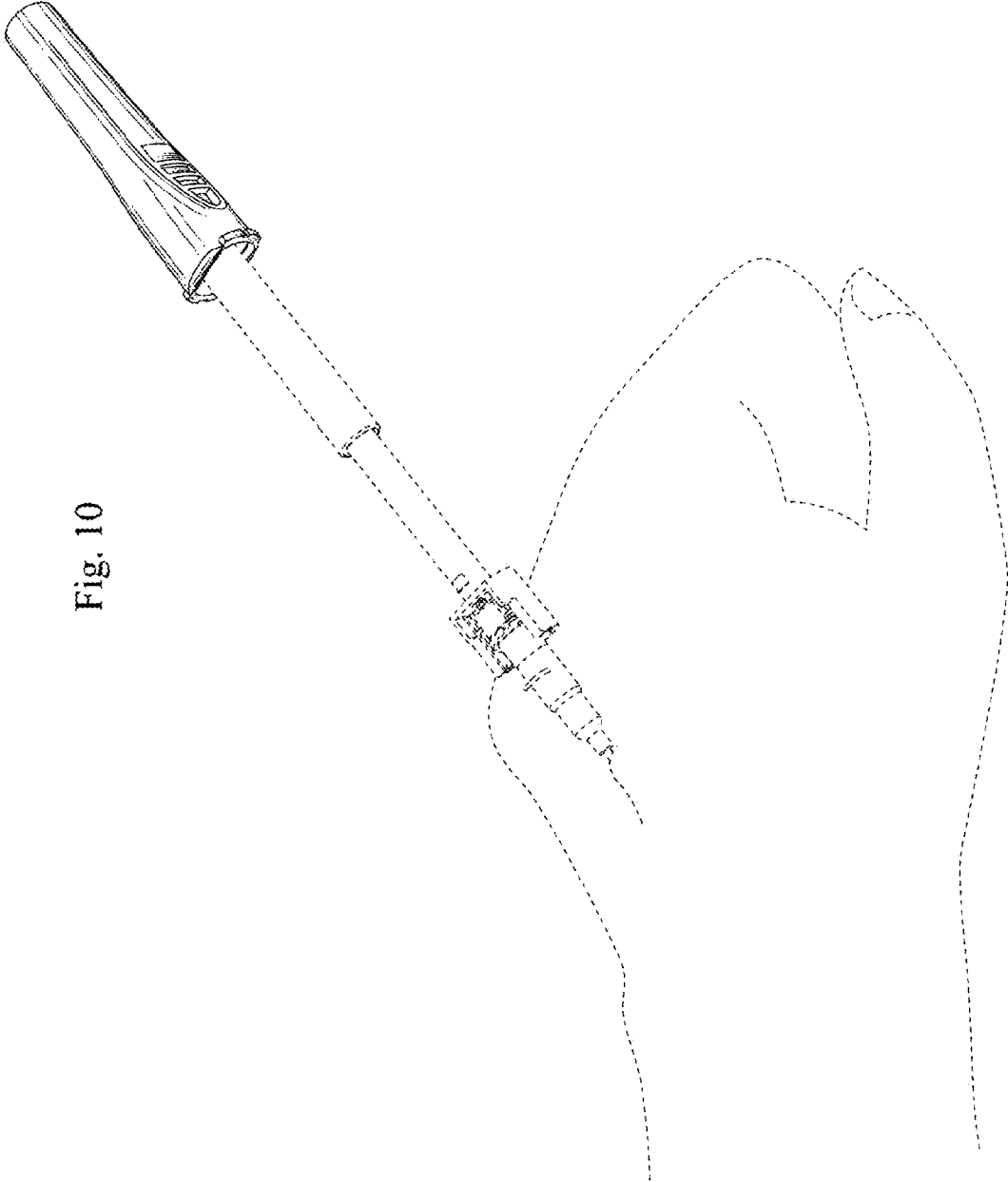

Fig. 10