



(51) International Patent Classification:

H01Q 1/24 (2006.01) H01Q 9/42 (2006.01)  
H01Q 1/52 (2006.01) H01Q 21/12 (2006.01)  
H01Q 5/00 (2006.01) H01Q 21/28 (2006.01)  
H01Q 9/04 (2006.01)

(21) International Application Number:

PCT/EP2013/062567

(22) International Filing Date:

18 June 2013 (18.06.2013)

(25) Filing Language:

English

(26) Publication Language:

English

(71) Applicant: TELEFONAKTIEBOLAGET L M ERICSSON (PUBL) [SE/SE]; SE-164 83 Stockholm (SE).

(72) Inventors: EK, Anders; Dammgårdsgatan 2B, S-42244 Hisings Backa (SE). KASPERSSON, Ola; Furubergsg. 3, S-43236 Varberg (SE). KARLSSON, Håkan; Kristinehöjdsgratan 17, S-41282 Göteborg (SE).

(74) Agent: VEJGAARD, Christian; Ericsson AB, Patent Unit GL, Lindholmospiren 11, S-417 56 Göteborg (SE).

(81) Designated States (unless otherwise indicated, for every kind of national protection available):

AE, AG, AL, AM, AO, AT, AU, AZ, BA, BB, BG, BH, BN, BR, BW, BY, BZ, CA, CH, CL, CN, CO, CR, CU, CZ, DE, DK, DM, DO, DZ, EC, EE, EG, ES, FI, GB, GD, GE, GH, GM, GT, HN, HR, HU, ID, IL, IN, IS, JP, KE, KG, KN, KP, KR, KZ, LA, LC, LK, LR, LS, LT, LU, LY, MA, MD, ME, MG, MK, MN, MW, MX, MY, MZ, NA, NG, NI, NO, NZ, OM, PA, PE, PG, PH, PL, PT, QA, RO, RS, RU, RW, SC, SD, SE, SG, SK, SL, SM, ST, SV, SY, TH, TJ, TM, TN, TR, TT, TZ, UA, UG, US, UZ, VC, VN, ZA, ZM, ZW.

(84) Designated States (unless otherwise indicated, for every kind of regional protection available):

ARIPO (BW, GH, GM, KE, LR, LS, MW, MZ, NA, RW, SD, SL, SZ, TZ, UG, ZM, ZW), Eurasian (AM, AZ, BY, KG, KZ, RU, TJ, TM), European (AL, AT, BE, BG, CH, CY, CZ, DE, DK, EE, ES, FI, FR, GB, GR, HR, HU, IE, IS, IT, LT, LU, LV, MC, MK, MT, NL, NO, PL, PT, RO, RS, SE, SI, SK, SM, TR), OAPI (BF, BJ, CF, CG, CI, CM, GA, GN, GQ, GW, KM, ML, MR, NE, SN, TD, TG).

Published:

— with international search report (Art. 21(3))

(54) Title: INVERTED F-ANTENNAS AT A WIRELESS COMMUNICATION NODE

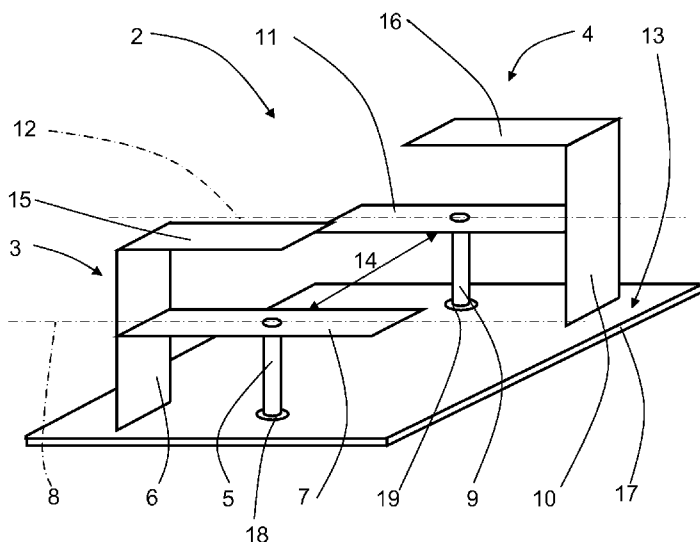

FIG. 2

(57) Abstract: The present invention relates to anode (1) in a wireless communication arrangement (W), the node (1) comprising an antenna arrangement (2) which in turn comprises a first and second inverted F antenna (3, 4). The inverted F antennas (3, 4) comprise a corresponding first and second feed connection (5, 9), first and second ground connection (6, 10) and a corresponding first and second radiating element (7, 11) mainly extending from the respective ground connection (6, 10) along a corresponding first and second longitudinal extension (8, 12.) The inverted F antennas (3, 4) are arranged on, or in, a plane. Furthermore, the first and second radiating elements (7, 11) are extending in opposite directions along their respective longitudinal extensions (8, 12) from the respective ground connections (6, 10), the first longitudinal extension (8) and the second longitudinal extension (12) being mutually parallel. The closest distance (14) between the first radiating element (7) and the second radiating element (11) exceeds  $0,4 \cdot \lambda_0$ , where  $\lambda_0$  is the wavelength for the centre frequency ( $f_0$ ) of the frequency band ( $f_B$ ) for which the inverted F antennas (3, 4) are intended.

WO 2014/202118 A1

## TITLE

5 Inverted F-antennas at a wireless communication node

## TECHNICAL FIELD

The present invention relates to a node in a communication system. The node comprises an antenna arrangement which in turn comprises a first inverted F antenna and a second inverted F antenna. The first inverted F antenna comprises a first feed connection, a first ground connection and a first radiating element mainly extending from the first ground connection along a first longitudinal extension. Correspondingly, the second inverted F antenna comprises a second feed connection, a second ground connection and a second radiating element mainly extending from the second ground connection along a second longitudinal extension. The inverted F antennas are arranged on, or in, a plane.

## BACKGROUND

Omni-directional antennas are often used for small cells such as so-called pico-cells and indoor coverage. Such antennas are also used at user terminals such as laptops and cell phones. The radiation pattern requirements will depend on which type of site and the propagation scenario that the antenna is intended for.

Most common in this context are vertically polarized omni-directional dipole antennas. When MIMO (Multiple Input Multiple Output) is introduced with several radio channels, multiple uncorrelated antennas are needed.

An uncorrelated sector antenna can be accomplished by using for example a patch-antenna with two orthogonal polarizations, vertical and horizontal. Orthogonal omni-directional antennas are considerably more difficult to accomplish, in particular an omni-directive, horizontally polarized wide band antenna. Most common is to use the horizontal distance between vertically polarized antennas to get uncorrelated radio channels.

Vertically polarized antennas must be well separated, in the order of several wavelengths, to achieve good multipath environment and therefore also good MIMO performance in all directions of the horizontal plane. However, large separation is not feasible when the antennas need to be integrated in small radio units and on low frequency bands. Half wave dipoles and micro strip patch antennas, for example, are relatively large, and a large separation between any two of these antennas becomes difficult to integrate in a small radio unit.

10 It is therefore a desire to provide a node in a wireless communication system that comprises an antenna arrangement that provides omni-directional coverage, an enhanced MIMO performance and that occupies a relatively small space.

#### SUMMARY

15 It is an object of the present invention to provide a node with an antenna arrangement that provides omni-directional coverage, an enhanced MIMO performance and that occupies a relatively small space.

Said object is obtained by means of a node in a communication system. The node comprises an antenna arrangement which in turn comprises a first inverted F antenna and a second inverted F antenna. The first inverted F antenna comprises a first feed connection, a first ground connection and a first radiating element mainly extending from the first ground connection along a first longitudinal extension. Correspondingly, the second inverted F antenna comprises a second feed connection, a second ground connection and a second radiating element mainly extending from the second ground connection along a second longitudinal extension. The inverted F antennas are arranged on, or in, a plane.

20 The first radiating element and the second radiating element are extending in opposite directions along their respective longitudinal extensions from the respective ground connections, where the first longitudinal extension and the second longitudinal extension are mutually parallel. The closest distance between the first radiating element and the second radiating element exceeds  $0,4 \cdot \lambda_0$ , where  $\lambda_0$  is the

30

wavelength for the centre frequency of the frequency band for which the inverted F antennas are intended.

5 According to an example, the first inverted F antenna comprises a first upper radiating element and the second inverted F antenna comprises a second upper radiating element.

10 According to another example, the plane is in the form of an electrically conducting ground plane positioned on a dielectric material.

15 According to another example, the antenna arrangement comprises planar inverted F antennas and a partially surrounding ground plane, where the inverted F antennas and the ground plane are arranged in a plane.

20 More examples are disclosed in the dependent claims.

A number of advantages are obtained by means of the present invention. For example:

- Suitable for integration into small radio units.
- 20 • Low profile and no protruding items.
- Enables enhanced 2x2 MIMO performance.
- Suitable for multiband applications.
- Displays small visual antenna volume .
- Provides an omni-directional antenna radiation pattern.

25

#### BRIEF DESCRIPTION OF THE DRAWINGS

The present invention will now be described more in detail with reference to the appended drawings, where:

30 Figure 1 shows a schematic view of a node in a wireless communication system;

Figure 2 shows a schematic perspective side view of an antenna arrangement according to a first example of the present invention;

Figure 3 shows a schematic top view of an antenna arrangement according to Figure 2; and

5 Figure 4 shows a schematic top view of an antenna arrangement according to a second example of the present invention.

#### DETAILED DESCRIPTION

With reference to Figure 1, there is a node 1 in a wireless communication arrangement W. The node 1, which for example may be in the form of a pico station  
10 or a user terminal, comprises an antenna arrangement 2.

With reference also to Figure 2 and Figure 3, showing a first example, the antenna arrangement 2 comprises a first inverted F antenna 3 and a second inverted F  
15 antenna 4. The first inverted F antenna 3 comprises a first feed connection 5, a first ground connection 6 and a first radiating element 7 mainly extending from the first ground connection 6 along a first longitudinal extension 8. Correspondingly, the second inverted F antenna 4 comprises a second feed connection 9, a second ground connection 10 and a second radiating element 11 mainly extending from the  
20 second ground connection 10 along a second longitudinal extension 12. The inverted F antennas 3, 4 are arranged on a plane 13, here in the form of an electrically conducting ground plane positioned on a dielectric material 17.

The first inverted F antenna 3 comprises a first upper radiating element 15, running  
25 parallel to the first radiating element 7 and being positioned farther away from the ground plane 13 than the first radiating element 7. Correspondingly, the second inverted F antenna 4 comprises a second upper radiating element 16, running parallel to the second radiating element 11 and being positioned farther away from the ground plane 13 than the second radiating element 11.

30

Each feed connection 5, 9 is running to, and electrically connecting, the corresponding first radiating element 7 and second radiating element 11 through a

corresponding aperture 18, 19 in the ground plane 13. In this way, the feed connections 5, 9 are not short-circuited to the ground plane 13.

Each radiating element 7, 11, 15, 16 runs parallel to the ground plane 13 and is in the form of a thin electrically conducting metal strip with a certain width.

According to the present invention, the first radiating elements 7, 15 and the second radiating elements 11, 16 are extending in opposite directions along their respective longitudinal extensions 8, 12 from the respective ground connections 6, 10, where the first longitudinal extension 8 and the second longitudinal extension 12 are mutually parallel. Furthermore, the closest distance 14 between the radiating elements 7, 11 exceeds  $0,4 \cdot \lambda_0$ , where  $\lambda_0$  is the wavelength for the centre frequency  $f_0$  of the frequency band  $f_B$  for which the inverted F antennas 3, 4 are intended.

With reference to Figure 4, showing a second example, it is also conceivable that the inverted F antennas are formed in one plane as etched structures, more commonly known as planar inverted F antennas (PIFA:s). This form allows a relatively thin structure. In Figure 4, there is an antenna arrangement 2' which comprises a first planar inverted F antenna 3' and a second planar inverted F antenna 4'. The first planar inverted F antenna 3' comprises a first feed connection 5' with an interconnecting first via 20, a first ground connection 6' and a first radiating element 7' mainly extending along a first longitudinal extension 8'. Correspondingly, the second planar inverted F antenna 4' comprises a second feed connection 9' with an interconnecting second via 21, a second ground connection 10' and a second radiating element 11' mainly extending along a second longitudinal extension 12'.

The planar inverted F antennas 3', 4' are formed in a plane, having been etched from an initial copper layer that now forms the planar inverted F antennas 3', 4' and a partially surrounding ground plane 13'. The ground plane 13' is as in the first example positioned on a dielectric material 17'.

The first radiating element 7' and the second radiating element 11' of the planar inverted F antennas 3', 4' are extending in opposite directions along their respective

longitudinal extensions 8', 12' from the respective ground connections 6', 10'. The first longitudinal extension 8' and the second longitudinal extension 12' are mutually parallel. Furthermore, the closest distance 14' between the first radiating elements 7' and the second radiating element 11' exceeds  $0,4 \cdot \lambda_0$ , where  $\lambda_0$  is the wavelength for the centre frequency  $f_0$  of the frequency band  $f_B$  for which the planar inverted F antennas 3', 4' are intended.

The interconnecting vias 20, 21 are further connected to a corresponding suitable feeding device (not shown), such as a corresponding radio unit.

10

The present invention thus uses two inverted F antennas 3, 4 that are mounted in opposite directions, i.e. one is rotated 180 degrees relative the other. The inverted F antennas 3, 4 may be placed at a corner or an edge at the ground plane 13/dielectric material 17. The separation between the inverted F antennas 3, 4 is such that the closest distance 14 between the first radiating element 7 and the second radiating element 11 exceeds  $0,4 \cdot \lambda_0$ , where  $\lambda_0$  is the wavelength for the centre frequency  $f_0$  of the frequency band  $f_B$  for which the planar inverted F antennas 3, 4 are intended. The present invention thus lies in the inventors' awareness of the advantages conferred by means of the combination of two inverted F antennas 3, 4 that are mounted in opposite directions, i.e. one is rotated 180 degrees relative the other, and of having a closest distance 14 between the radiating elements 7, 11 that exceeds  $0,4 \cdot \lambda_0$  according to the above.

15

By means of the arrangement above, the polarizations of the inverted F antennas 3, 4 become mutually orthogonal. For example, if the radiated power at the first feed connection 5 has right hand circular polarization, the radiated power at the second feed connection 9 has left hand circular polarization.

20

The inverted F antennas 3, 4 are oriented so that the antenna patterns are uncorrelated and have a good gain balance in all directions of the horizontal plane. This concept creates an omni-directional antenna with uncorrelated patterns and hence good MIMO (Multiple Input Multiple Output) performance.

25

30

Figure 2 and Figure 3 show two inverted F antennas 3, 4 mounted at the edges of a ground plane 13 in a node 1. In a functional example, the inverted F antennas 3, 4 are mounted in a sink that will have an additional environmental cover. The inverted F antennas 3, 4 are furthermore tuned to be operating at a relatively low centre  
5 frequency such as 720 MHz, which is low in relation to the electrical size of the ground plane 13. This is only one example, many other types of arrangements and frequencies are of course conceivable.

In comparison, two dipoles would need to be mounted on top of the unit. These  
10 would constitute protruding objects that would disturb mounting and/or handling of the node itself.

An inverted F antenna is an inherently much smaller antenna element than for example a half-wave dipole or a microstrip patch antenna. The resonant size of an  
15 inverted F antenna is only one quarter of a wavelength, and it can be made very thin.

The present invention is not limited to the examples above, but may vary freely within the scope of the appended claims. For example, the inverted F antennas 3, 4 are shown as having equal design; this is not necessary, and they may have design  
20 differences as long as the functionality is preserved.

Although each inverted F antenna 3, 4 has been shown to have two radiating elements each, this is only by way of example. Each inverted F antenna 3, 4 may comprises any number of radiating elements, but at least one which is connected to  
25 feed connection. As an example, one inverted F antenna may have two radiating elements and the other inverted F antenna may have one radiating element.

The inverted F antennas 3, 4 do not have to be positioned facing each other along their respective longitudinal extensions 8, 12, but each inverted F antennas 3, 4 may  
30 be suitably positioned along its longitudinal extension 8, 12.

Although the description above has related to a RBS in a wireless communications system, the present invention may relate to any type of node 1 in a communication

system 2, where communication either is wireless and/or via some type of wire such as copper or fiber. The node may be constituted by a hand-held device or a base station, for example a base station, a repeater device or a user terminal that is communicating with another device. A user terminal may for example be in the form of a cell phone, a laptop computer or a touch pad device.

The present invention applies to any F-shaped antenna, such as the previously described planar inverted F-antenna (PIFA), and may be realized in various forms and implementations. For example, the strips forming the inverted F antennas in the first example may be made in any suitable conducting material, even metalized plastic. A PIFA may have radiating elements that are meandered in order to occupy less surface area.

The antenna arrangement 2 is arranged to be used in both transmission and reception, normally having reciprocal radiation properties.

The inverted planar F antennas 3', 4' and the ground plane 13' may for example either be etched from an initial copper layer that is positioned on a dielectric material 17', or formed from sheet metal parts that are positioned on a carrier material, such as a dielectric material 17'. Such sheet metal parts may be cut out from a larger sheet of metal, for example by means of a laser cutting device.

Terms such as orthogonal and parallel are not to be interpreted as mathematical exact, but within what is practically obtainable within this field of technology.

## CLAIMS

5

1. A node (1) in a wireless communication arrangement (W), the node (1) comprising an antenna arrangement (2), the antenna arrangement (2) in turn comprising a first inverted F antenna (3) and a second inverted F antenna (4), the first inverted F antenna (3) comprising a first feed connection (5), a first ground connection (6) and a first radiating element (7) mainly extending from the first ground connection (6) along a first longitudinal extension (8), and the second inverted F antenna (4) comprising a second feed connection (9), a second ground connection (10) and a second radiating element (11) mainly extending from the second ground connection (10) along a second longitudinal extension (12), the inverted F antennas (3, 4) being arranged on, or in, a plane (13), **characterized in** that the first radiating element (7) and the second radiating element (11) are extending in opposite directions along their respective longitudinal extensions (8, 12) from the respective ground connections (6, 10), the first longitudinal extension (8) and the second longitudinal extension (12) being mutually parallel, where the closest distance (14) between the first radiating element (7) and the second radiating element (11) exceeds  $0,4 \cdot \lambda_0$ , where  $\lambda_0$  is the wavelength for the centre frequency ( $f_0$ ) of the frequency band ( $f_B$ ) for which the inverted F antennas (3, 4) are intended.

2. A node according to claim 1, **characterized in** that the first inverted F antenna (3) comprises a first upper radiating element (15) and that the second inverted F antenna (3) comprises a second upper radiating element (16).

3. A node according to any one of the claims 1 or 2, **characterized in** that each radiating element runs parallel to the plane (13).

30

4. A node according to any one of the previous claims, **characterized in** that the plane (13) is in the form of an electrically conducting ground plane positioned on a dielectric material (17).

5. A node according to claim 4, **characterized in** that each feed connection (5, 9) is running to the corresponding radiating element (7, 11) through a corresponding aperture (18, 19) in the ground plane (13).

5

6. A node according to claim 1, **characterized in** that the antenna arrangement (2) comprises planar inverted F antennas (3', 4') and a partially surrounding ground plane (13'), where the inverted F antennas (3', 4') and the ground plane (13') are arranged in a plane.

10

7. A node according to claim 6, **characterized in** that the inverted F antennas (3', 4') and the ground plane (13') either are etched from an initial copper layer that is positioned on a dielectric material (17'), or are formed from sheet metal parts that are positioned on a carrier material.

15

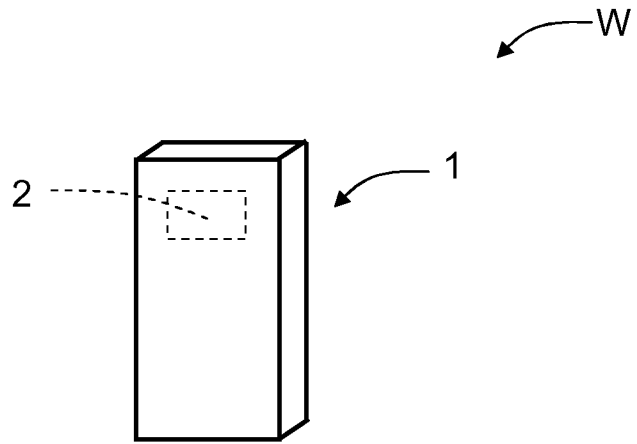

FIG. 1

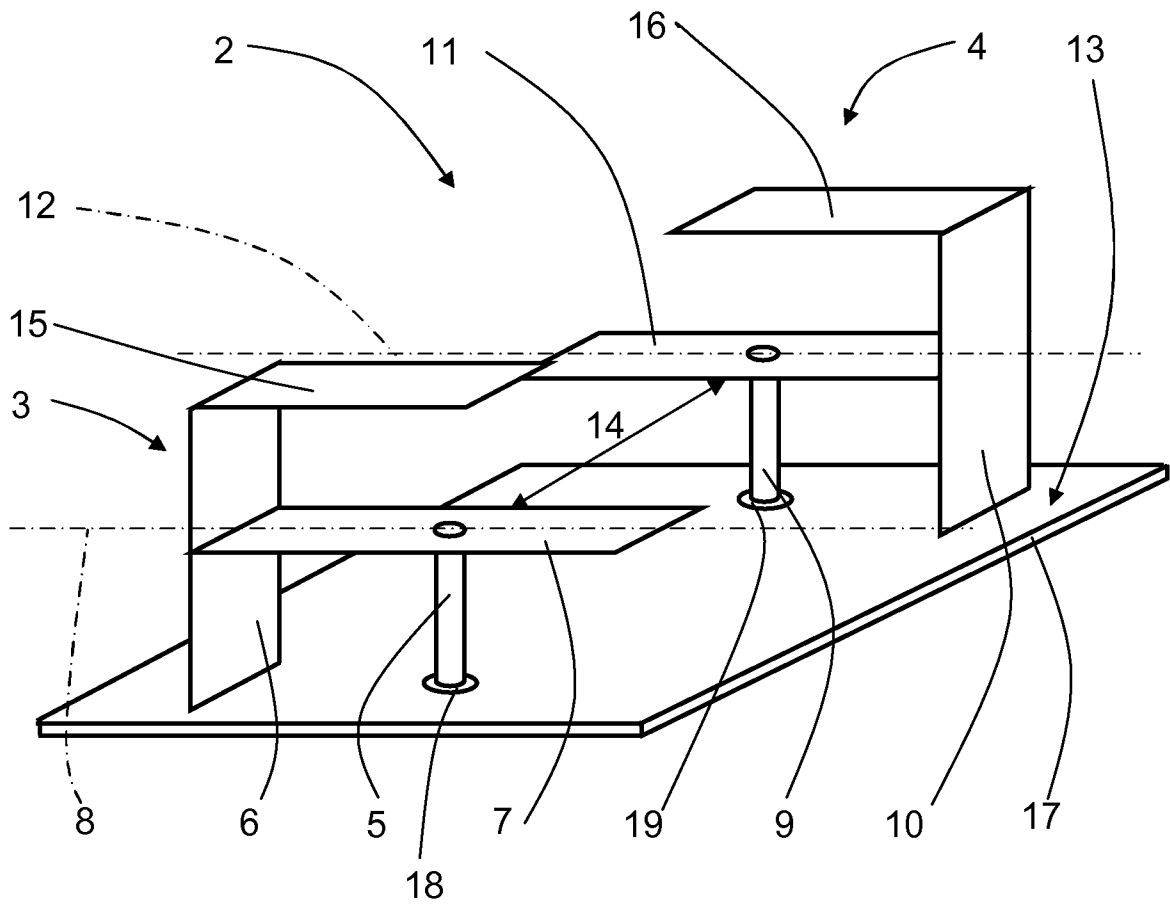

FIG. 2

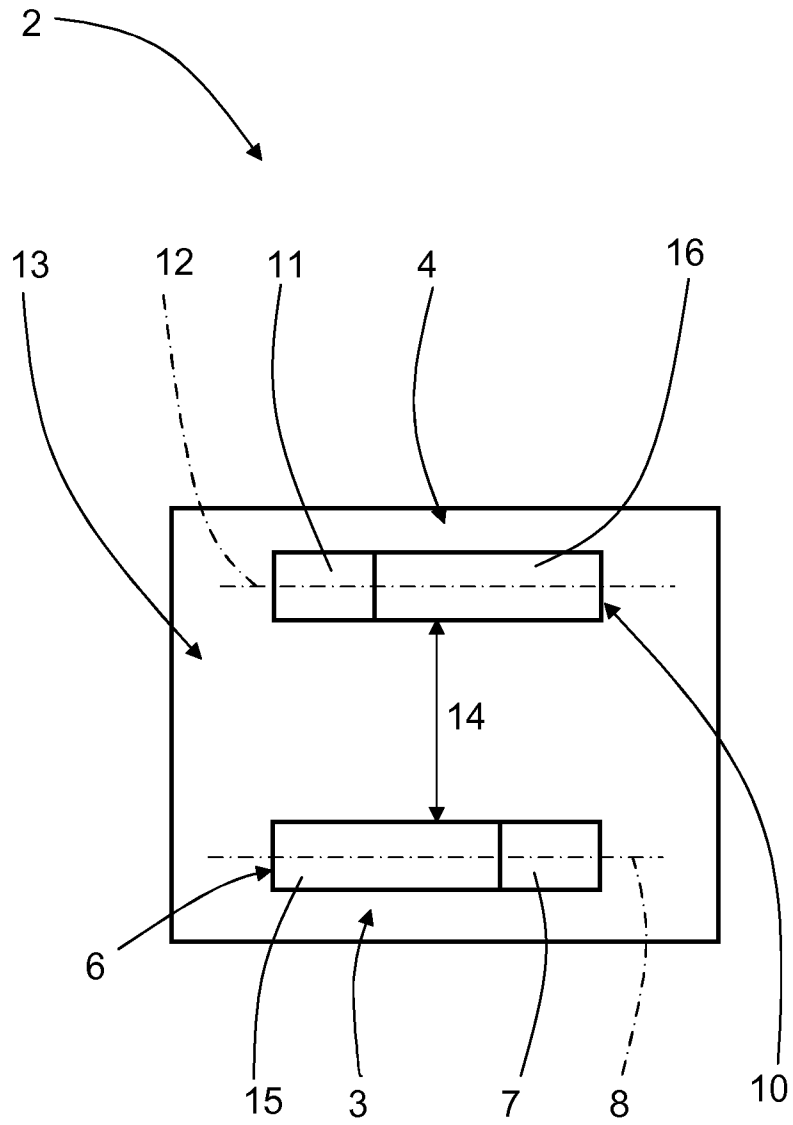

FIG. 3

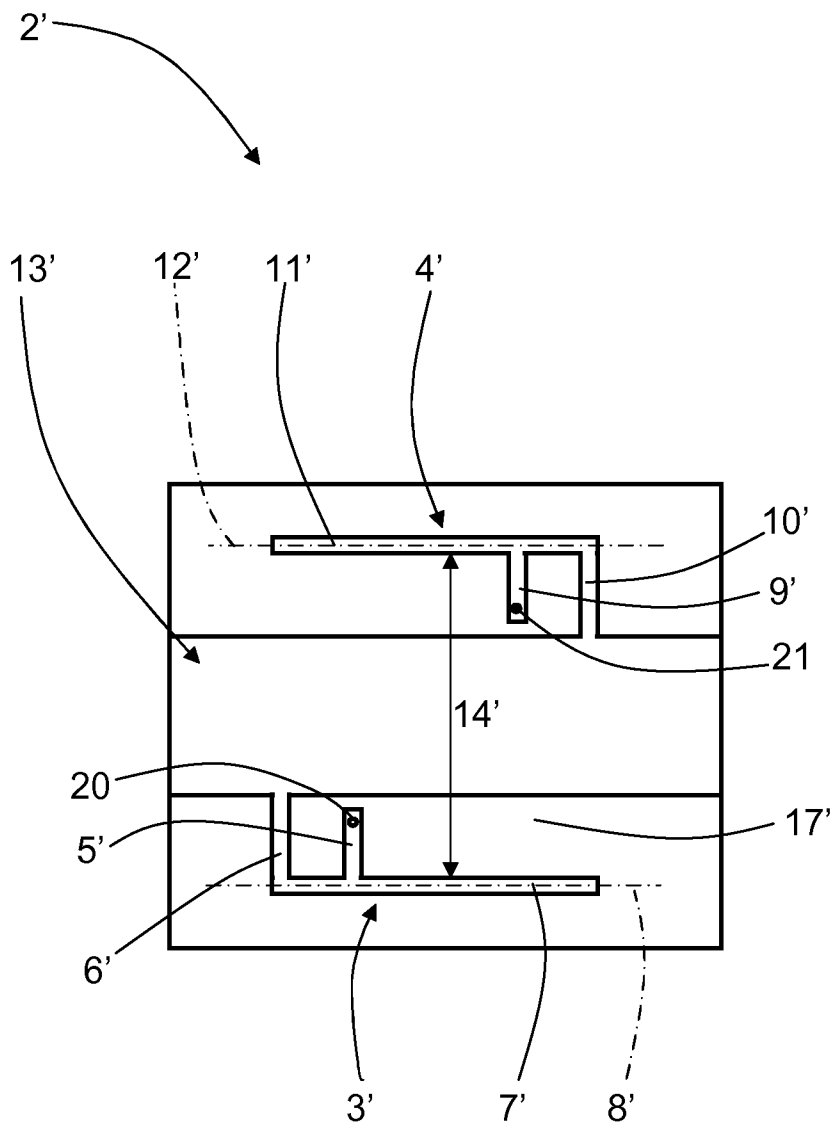

FIG. 4

**INTERNATIONAL SEARCH REPORT**

International application No  
PCT/EP2013/062567

**A. CLASSIFICATION OF SUBJECT MATTER**  
 INV. H01Q1/24 H01Q1/52 H01Q5/00 H01Q9/04 H01Q9/42  
 H01Q21/12 H01Q21/28  
 ADD.  
 According to International Patent Classification (IPC) or to both national classification and IPC

**B. FIELDS SEARCHED**  
 Minimum documentation searched (classification system followed by classification symbols)  
 H01Q  
 Documentation searched other than minimum documentation to the extent that such documents are included in the fields searched

Electronic data base consulted during the international search (name of data base and, where practicable, search terms used)  
 EPO-Internal, WPI Data

**C. DOCUMENTS CONSIDERED TO BE RELEVANT**

Category*	Citation of document, with indication, where appropriate, of the relevant passages	Relevant to claim No.
X	US 5 835 063 A (BRACHAT PATRICE [FR] ET AL) 10 November 1998 (1998-11-10)	1,3-7
Y	column 7, line 5 - line 35; figure 7 -----	2
X	US 2008/094302 A1 (MURCH ROSS D [CN] ET AL) 24 April 2008 (2008-04-24)	1,3-5,7
Y	paragraph [0024] - paragraph [0029]; figure 3; table 2 -----	2
Y	WO 2009/080110 A1 (ERICSSON TELEFON AB L M [SE]; PERSSON PATRIK [SE]; JOHANSSON MARTIN NI) 2 July 2009 (2009-07-02)	1-7
	page 6, line 10 - page 9, line 24; figure 2 ----- -/--	

Further documents are listed in the continuation of Box C.  See patent family annex.

\* Special categories of cited documents :

"A" document defining the general state of the art which is not considered to be of particular relevance	"T" later document published after the international filing date or priority date and not in conflict with the application but cited to understand the principle or theory underlying the invention
"E" earlier application or patent but published on or after the international filing date	"X" document of particular relevance; the claimed invention cannot be considered novel or cannot be considered to involve an inventive step when the document is taken alone
"L" document which may throw doubts on priority claim(s) or which is cited to establish the publication date of another citation or other special reason (as specified)	"Y" document of particular relevance; the claimed invention cannot be considered to involve an inventive step when the document is combined with one or more other such documents, such combination being obvious to a person skilled in the art
"O" document referring to an oral disclosure, use, exhibition or other means	"&" document member of the same patent family
"P" document published prior to the international filing date but later than the priority date claimed	

Date of the actual completion of the international search <b>5 March 2014</b>	Date of mailing of the international search report <b>13/03/2014</b>
--	---

Name and mailing address of the ISA/ European Patent Office, P.B. 5818 Patentlaan 2 NL - 2280 HV Rijswijk Tel. (+31-70) 340-2040, Fax: (+31-70) 340-3016	Authorized officer <b>Kaleve, Abraham</b>
--	--

## INTERNATIONAL SEARCH REPORT

International application No  
PCT/EP2013/062567

C(Continuation). DOCUMENTS CONSIDERED TO BE RELEVANT		
Category*	Citation of document, with indication, where appropriate, of the relevant passages	Relevant to claim No.
Y	THAYSEN J ET AL: "DESIGN CONSIDERATIONS FOR LOW ANTENNA CORRELATION AND MUTUAL COUPLING REDUCTION IN MULTI ANTENNA TERMINALS", EUROPEAN TRANSACTIONS ON TELECOMMUNICATIONS, WILEY & SONS, CHICHESTER, GB, vol. 18, no. 3, 1 April 2007 (2007-04-01), pages 319-326, XP001542038, ISSN: 1124-318X, DOI: 10.1002/ETT.1111 paragraph [002.]; figure 4a -----	1-7
Y	EP 2 083 472 A1 (APPLE INC [US]) 29 July 2009 (2009-07-29)	2
A	paragraph [0064] - paragraph [0066]; figure 7 paragraph [0058] -----	7
Y	US 2005/195119 A1 (GAUCHER BRIAN PAUL [US] ET AL) 8 September 2005 (2005-09-08)	2
A	figure 7A paragraph [0068] -----	7

# INTERNATIONAL SEARCH REPORT

Information on patent family members

International application No PCT/EP2013/062567
---

Patent document cited in search report	Publication date	Patent family member(s)	Publication date
US 5835063	A	10-11-1998	DE 69531655 D1 09-10-2003
			DE 69531655 T2 24-06-2004
			EP 0714151 A1 29-05-1996
			FR 2727250 A1 24-05-1996
			JP H08256009 A 01-10-1996
			US 5835063 A 10-11-1998
-----			
US 2008094302	A1	24-04-2008	US 2008094302 A1 24-04-2008
			WO 2008049354 A1 02-05-2008
-----			
WO 2009080110	A1	02-07-2009	CN 101971424 A 09-02-2011
			EP 2232642 A1 29-09-2010
			US 2010297971 A1 25-11-2010
			WO 2009080110 A1 02-07-2009
-----			
EP 2083472	A1	29-07-2009	CN 201430211 Y 24-03-2010
			EP 2083472 A1 29-07-2009
			US 2009174611 A1 09-07-2009
			US 2011169703 A1 14-07-2011
			US 2012169550 A1 05-07-2012
-----			
US 2005195119	A1	08-09-2005	CN 1930732 A 14-03-2007
			DE 112005000344 T5 29-04-2010
			GB 2430081 A 14-03-2007
			JP 2007535836 A 06-12-2007
			TW I303900 B 01-12-2008
			US 2005195119 A1 08-09-2005
			WO 2005093901 A1 06-10-2005
-----			