

(No Model.)

J. R. CADWELL.
COMBINED FOUNTAIN AND SPRINKLER.

No. 528,144.

Patented Oct. 30, 1894.

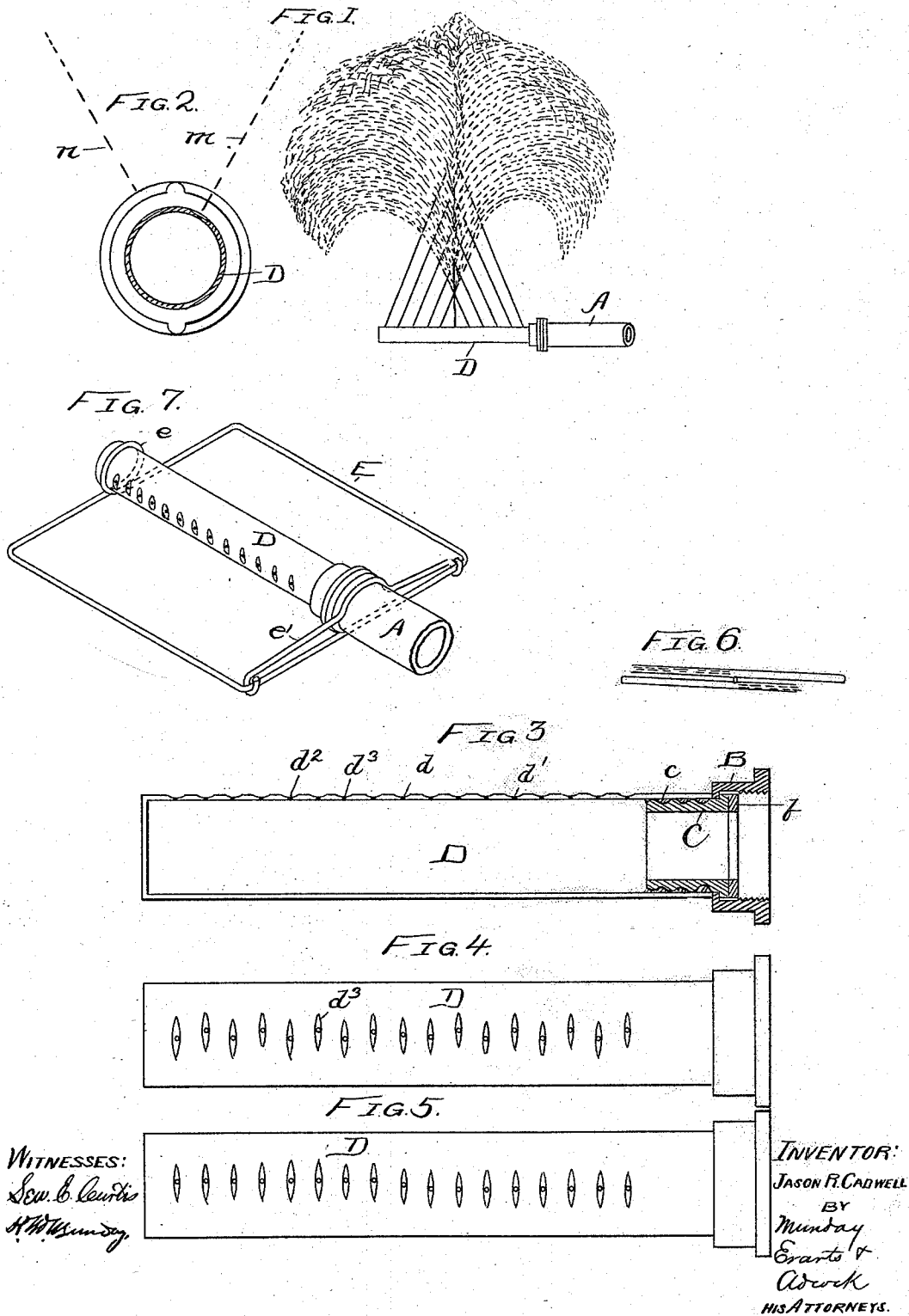

UNITED STATES PATENT OFFICE.

JASON R. CADWELL, OF CHICAGO, ILLINOIS.

COMBINED FOUNTAIN AND SPRINKLER.

SPECIFICATION forming part of Letters Patent No. 528,144, dated October 30, 1894.

Application filed January 17, 1894. Serial No. 497,146. (No model.)

To all whom it may concern:

Be it known that I, JASON R. CADWELL, a citizen of the United States, residing in Woodlawn Park, Chicago, in the county of Cook and State of Illinois, have invented a new and useful Improvement in a Combined Fountain and Sprinkler, of which the following is a specification.

This invention relates to the construction of a combined fountain and sprinkler, which has been designed mainly for use in sprinkling lawns, but which is adapted for use in other places.

The invention consists in a combined fountain and sprinkler consisting of a tube closed at one end and adapted to be secured to the hose or pipe at the other end and provided at intervals upon one side and between its ends with a series of jetting orifices arranged longitudinally of the sprinkler and those at each side of the center of the series being inclined in a longitudinal direction and toward those at the other side of the center, so that the streams will converge and come together in air. There is a corresponding number of orifices at each side of the center, and by reason of this arrangement and their inclination each jet meets a corresponding jet, and the points at which the pairs of jets meet are successively further from the sprinkler. The result attending all these features of construction is a beautiful fountain effect in which the spray falls in curved lines and describes a graceful outline.

In the accompanying drawings which form a part of this specification, Figure 1 is a side elevation showing my improved fountain sprinkler in operation. Fig. 2 is a transverse section and Fig. 3 is a longitudinal section of the device. Figs. 4 and 5 are plan views of the sprinkler showing the arrangement of the jetting orifices. Fig. 6 is a top diagram of the water thrown by the sprinkler. Fig. 7 is a perspective showing the device and a simple form of holder in which it may be secured while in use.

In the drawings A represents a hose or pipe to which my fountain sprinkler is attached.

B is a female swivel secured upon the sprinkler and adapted to receive the male part of the coupling which is carried by the hose.

D is a tube closed at its outer end, as shown, and carrying the swivel B at its other end and forming my improved fountain sprinkler. For convenience in attaching the swivel, a sleeve C is inserted in the open end of the tube and secured therein by running molten lead into the space between the interior of the tube and the corrugated exterior of the sleeve, as shown at *c*. This sleeve has an outwardly extending shoulder adapted to engage the swivel, as plainly indicated at Fig. 3. *b* represents the usual rubber packing ring.

The tube D along one of its sides is provided with a series of radial jetting openings, arranged in a longitudinal line or row and inclined so that the streams formed by them may be directed against each other as now to be described. The middle opening or openings *d* I prefer to bore in a direction at right angles to the axis of the tube and the openings *d'* at one side of the center I incline so that their streams will be directed toward the center and the openings *d''* at the other side of the center are inclined in the opposite direction so that their streams are also directed toward the center. There is a corresponding number of openings at each side of the center.

The openings *d'* and *d''* are also preferably set at one side or the other of the longitudinal plane running through the central opening *d*, as shown at either Fig. 4 or Fig. 5. It will also be noticed that at the points where the openings are located, the outer surface of the tube is filed away forming transverse grooves *d³* and so reducing the thickness of the metal at two opposite sides of the openings as to give the water opportunity to spread or widen out at those sides, and thus produce flat streams instead of round ones. Another desirable peculiarity of the action is that while the streams are directed toward each other they do not in fact meet squarely, but they are so directed as that they will interfere with each other sufficiently to insure their being changed by their contact from continuous streams into fine drops and spray; but this interference should not, if the sprinkler is to be used as a fountain, be such as to deprive the water of its force or momentum, but on the contrary the larger portion of it should continue on its course in the direction

first imparted to it and thus spread the water widely in the line of the openings, and cause it to assume the fan-like shape, and so that it may cover a large area when used for sprinkling purposes. The action of the water is such as to give it a very beautiful and attractive appearance, especially when the sun shines through it. The streams from the sprinkler may be diverted from one side to the other by simply turning the hose a trifle, as for instance from the direction given by the line *m* Fig. 2 to the line *n*. The sprinkler may also be shifted in position at will by means of the hose, and the user by first turning it so that the water is directed wholly to one side or downward, may approach and take direct hold of it and even raise it from the ground while the water is playing without danger of being wet. The tube corresponds substantially in diameter with that of the hose, and being without projections upon its outer surface it can be drawn over the lawn with as much freedom as the hose itself.

I prefer in the use of my fountain sprinkler to secure it to some sort of a holder which will not interfere with its movements or adjustments, so that when correctly positioned to throw the water in the direction desired, it will retain such position with certainty and not be too easily turned away therefrom. One construction of such holder is shown at E, Fig. 4 and is made preferably of wire. This wire is bent into a square or rectangular form with an eye at *e*, and a clamping end or separate wire *e'* is carried over the hose and hooked under the frame. By this clamping wire *e'* I create a sufficient friction upon the hose to retain it against undesired rotation and the wire is of course easily released; but this friction is not sufficient to prevent the adjustment of the sprinkler by twisting the hose, as previously described. The laterally extending portions of this wire frame or holder are adapted not only to thus maintain the sprinkler against turning upon its axis, but also to prevent the holder itself from turning. The tip of the sprinkler is inserted in the eye *e*.

Any form of holder may be used with the sprinkler which will permit it to be turned

axially, and which will allow its free movement about the lawn, but I have used the device without any holder and with great success.

The interference of the streams is perhaps most easily obtained by locating them as shown, but they may be otherwise located if they are properly inclined to give the desired direction to the jet.

I claim—

1. The combined fountain and sprinkler consisting of a tube closed at one end and adapted to be secured to the hose at the other end and further adapted to be moved from place to place and turned axially by moving or turning the hose, and provided with a series of lateral jetting orifices arranged in a row longitudinal of the sprinkler, those at either side of the center of the series being inclined in a longitudinal direction and toward those at the other side of the center, substantially as specified.

2. The combined movable fountain and sprinkler consisting of a tube closed at one end and adapted to be secured to the hose at the other end, and provided with a series of longitudinally converging jetting orifices arranged in a row longitudinal of the sprinkler substantially as specified.

3. The combined fountain and sprinkler consisting of a tube closed at one end and adapted to be secured to the hose at the other end, and provided with a series of jetting orifices arranged in a row longitudinal of the sprinkler, the outer surface of the sprinkler being grooved at opposite sides of the orifices to widen the streams delivered therefrom in a direction transverse of the sprinkler, substantially as specified.

4. A sprinkler having a series of lateral jetting orifices arranged in a row longitudinally of the sprinkler and delivering converging streams, the outer surface of the sprinkler at opposite sides of the orifices being cut away so as to widen the jets in a direction across the sprinkler, substantially as set forth.

JASON R. CADWELL.

Witnesses:

EDW. S. EVARTS,
H. W. MUNDAY.