



(12) **EUROPEAN PATENT APPLICATION**

(88) Date of publication A3:
24.12.2014 Bulletin 2014/52

(51) Int Cl.:
B65H 67/06 (2006.01)

(43) Date of publication A2:
11.12.2013 Bulletin 2013/50

(21) Application number: **13164187.0**

(22) Date of filing: **17.04.2013**

(84) Designated Contracting States:
AL AT BE BG CH CY CZ DE DK EE ES FI FR GB GR HR HU IE IS IT LI LT LU LV MC MK MT NL NO PL PT RO RS SE SI SK SM TR
 Designated Extension States:
BA ME

(72) Inventor: **Inoue, Kei**
Kyoto, Kyoto 612-8686 (JP)

(74) Representative: **Beck, Alexander**
Hansmann & Vogeser
Patent- und Rechtsanwälte
Maximilianstrasse 4b
82319 Starnberg (DE)

(30) Priority: **08.06.2012 JP 2012131373**

(71) Applicant: **Murata Machinery, Ltd.**
Kyoto-shi, Kyoto 601-8326 (JP)

(54) **Automatic winder**

(57) An automatic winder (100) includes a winding unit (10) that unwinds a yarn from yarn-wound bobbins (YB) mounted on trays (22) and forms a package, a bobbin transporting device (11) that transports the trays (22), a bobbin supplying device (12) that supplies a yarn-wound bobbin (YB) to a tray (22) with no yarn-wound bobbin (YB) mounted thereon from among the trays (22) transported by the bobbin transporting device (11), a bobbin removing device (13) that removes yarn-unwound

bobbins (B) from the trays (22) that are transported by the bobbin transporting device (11), and a collection box (40) into which the yarn-unwound bobbins (B) removed by the bobbin removing device (13) and introduced in uniform bobbin tube large/small-end orientation are collected. The bobbin supplying device (12) includes a box mounting member (43) on which the collection box (40) is mounted.

FIG.2

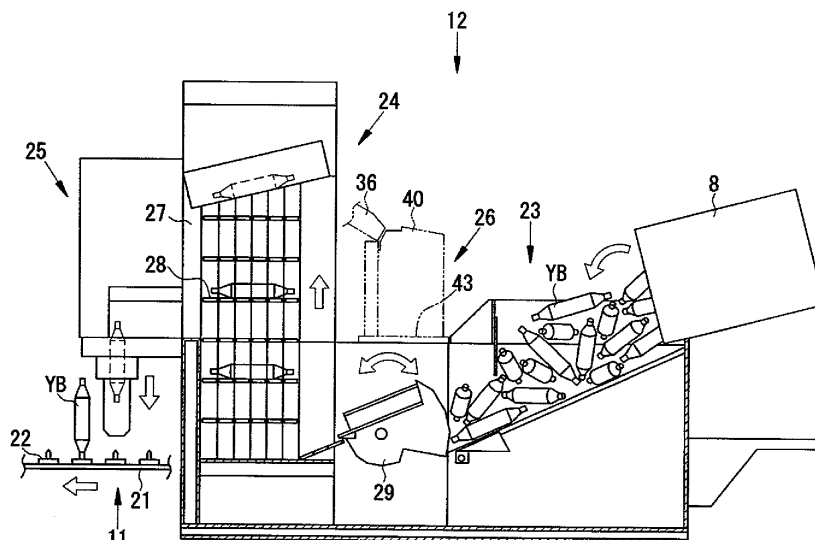



EUROPEAN SEARCH REPORT

Application Number
EP 13 16 4187

5

10

15

20

25

30

35

40

45

50

55

DOCUMENTS CONSIDERED TO BE RELEVANT			
Category	Citation of document with indication, where appropriate, of relevant passages	Relevant to claim	CLASSIFICATION OF THE APPLICATION (IPC)
A	US 4 634 066 A (MATSUI ISAMU [JP] ET AL) 6 January 1987 (1987-01-06) * column 10, lines 6-26; figures 1,2 * -----	1-14	INV. B65H67/06
A	US 4 676 061 A (YAMAMOTO YOSHIO [JP]) 30 June 1987 (1987-06-30) * claims 1-6; figures 1-7 * -----	1-14	
A	EP 0 345 480 A2 (MOVIND S A S DI VITALI GIANFRA [IT]) 13 December 1989 (1989-12-13) * figure 1 * -----	1-14	
The present search report has been drawn up for all claims			TECHNICAL FIELDS SEARCHED (IPC)
			B65H
Place of search		Date of completion of the search	Examiner
The Hague		19 November 2014	Pussemier, Bart
CATEGORY OF CITED DOCUMENTS		T : theory or principle underlying the invention E : earlier patent document, but published on, or after the filing date D : document cited in the application L : document cited for other reasons	
X : particularly relevant if taken alone Y : particularly relevant if combined with another document of the same category A : technological background O : non-written disclosure P : intermediate document		& : member of the same patent family, corresponding document	

1
EPO FORM 1503 03.82 (F04C01)

**ANNEX TO THE EUROPEAN SEARCH REPORT
ON EUROPEAN PATENT APPLICATION NO.**

EP 13 16 4187

5

This annex lists the patent family members relating to the patent documents cited in the above-mentioned European search report. The members are as contained in the European Patent Office EDP file on
The European Patent Office is in no way liable for these particulars which are merely given for the purpose of information.

10

19-11-2014

15

20

25

30

35

40

45

50

55

Patent document cited in search report	Publication date	Patent family member(s)	Publication date
US 4634066 A	06-01-1987	CH 666469 A5	29-07-1988
		DE 3431790 A1	28-03-1985
		ES 8605306 A1	16-08-1986
		IT 1179235 B	16-09-1987
		JP S6048871 A	16-03-1985
		US 4634066 A	06-01-1987
		-----	-----
US 4676061 A	30-06-1987	CH 669947 A5	28-04-1989
		DE 3422134 A1	20-12-1984
		FR 2548223 A1	04-01-1985
		IT 1179203 B	16-09-1987
		JP H021057 B2	10-01-1990
		JP S59230973 A	25-12-1984
		US 4676061 A	30-06-1987
-----	-----	-----	
EP 0345480 A2	13-12-1989	EP 0345480 A2	13-12-1989
		IT 1219705 B	24-05-1990
-----	-----	-----	-----

EPO FORM P0459

For more details about this annex : see Official Journal of the European Patent Office, No. 12/82