

(No Model.)

G. W. MANSFIELD.
ELECTRIC MOTOR.

No. 406,922.

Patented July 16, 1889.

Fig. 2,

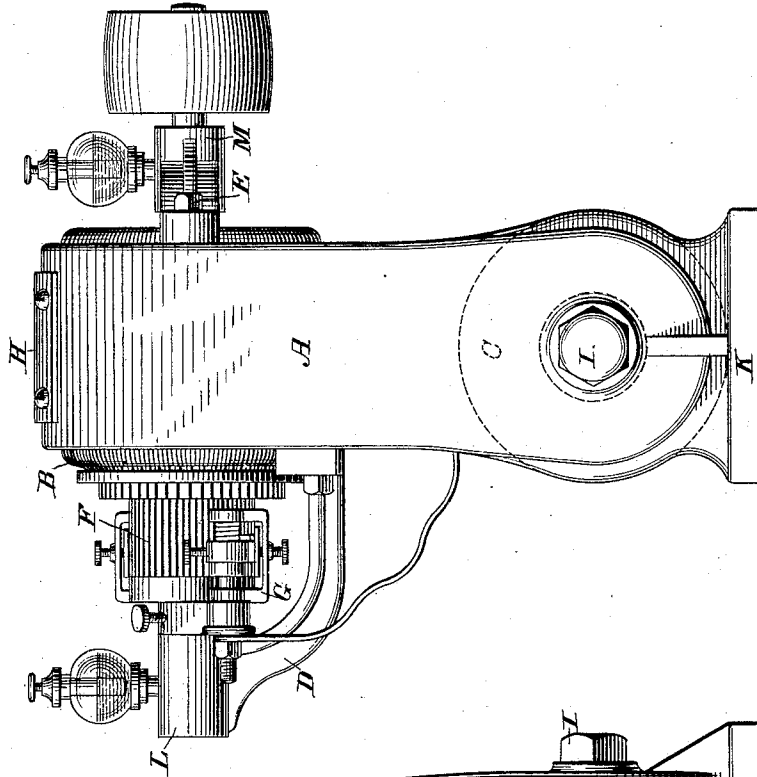
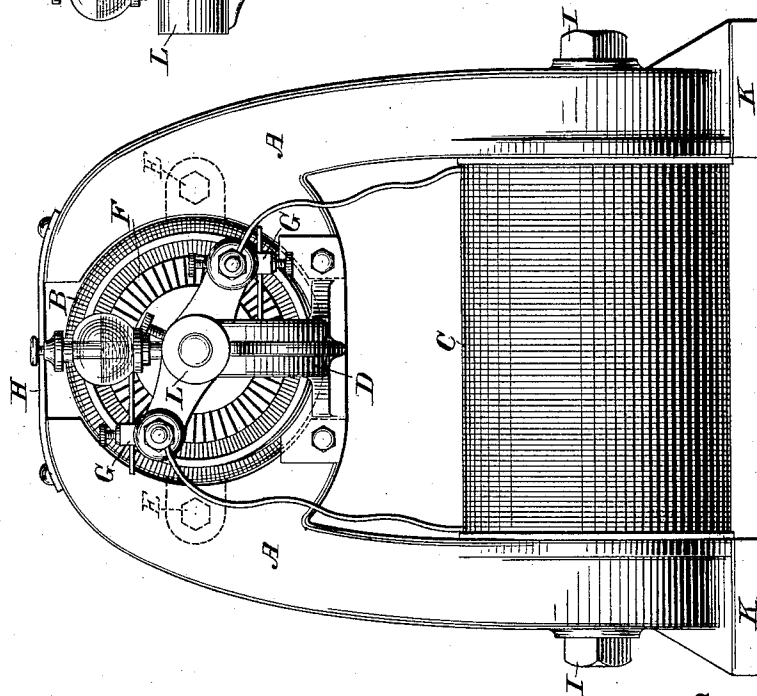

Fig. 1,



Witnesses

P. B. Keefer
Carrie C. Ashley

Inventor

Geo. W. Mansfield

By his Attorney

A. S. Dyer

UNITED STATES PATENT OFFICE.

GEORGE W. MANSFIELD, OF CLEVELAND, OHIO, ASSIGNOR TO MATTHEW H. ROBINSON AND ORLANDO A. FOSTER, OF BOSTON, MASSACHUSETTS.

ELECTRIC MOTOR.

SPECIFICATION forming part of Letters Patent No. 406,922, dated July 16, 1889.

Application filed February 27, 1889. Serial No. 301,137. (No model.)

To all whom it may concern:

Be it known that I, GEORGE W. MANSFIELD, a citizen of the United States, residing at Cleveland, in the county of Cuyahoga and State of Ohio, have invented certain new and useful Improvements in Electric Motors; and I do hereby declare the following to be a full, clear, and exact description of the invention, such as will enable others skilled in the art to which it appertains to make and use the same.

This invention relates to electric motors.

The object of the invention is to construct a motor as cheaply as possible with but few parts, and one that shall be extremely simple in construction.

With these objects in view, the invention consists in the details of construction herein-after described, which will be specifically pointed out in the claim appended hereto.

I have illustrated the invention in the accompanying drawings, in which—

Figure 1 shows an elevation of a motor constructed in accordance with my invention, and Fig. 2 represents a side elevation of the same.

In the drawings, A represents the polar extensions of an electro-magnet C, the extensions projecting so as to leave a space for the armature B, and being shaped at the lower part into feet K for supporting the motor. These feet may be designed in any way to support the motor, and should be supplied with holes through which screws can be passed to attach the motor to the floor. It will be observed that the feet K of the motor are not far removed from the neutral point and the electro-magnet C, and therefore that but little magnetism will exist at these points, so that there will be no dissipation or short-circuiting of magnetism, even though they rest upon a conducting-body, the magnetism all being practically contained in the polar extensions A opposite the armature B. The electro-magnet C has a wrought-iron-bar core, to which the polar extensions A are fastened by a bolt and nut I. The polar extensions A are cast in the form shown. Between these

two extensions is left a space for an armature B; which may be a Gramme ring, or any other suitable form of armature. The said armature is provided with a commutator F and a brush-holder G, all of which is supported by two bearings L and M, the former of which is sustained by a curved arm D, which is bolted to each of the polar extensions below the armature. This arm D should be made of non-magnetic material or magnetically insulated from the polar extensions, so as to prevent a short-circuiting of the magnetism. It could be made of brass, phosphor-bronze, or any other suitable metal. The bearing M is supported by a curved or bow-shaped casting E, each end of which is attached to one of the polar extensions A. It is arranged at right angles to the plane of the arm D. This casting E should be made of the same material and the same precautions taken as with reference to the arm D, before described. If found necessary, a non-magnetic plate H can be employed to span the space between the polar extensions, as shown in Fig. 1, so as to afford means for making the structure more rigid. A pulley is placed upon the armature-shaft near the bearing M, so that the motor may be belted to any mechanism. The bearings L and M may be provided with oil-cups, as shown in the drawings. The armature and magnet C may be wound in any manner desired. This makes no part of my invention.

It will be observed that the motor I have described is extremely simple, and is composed of but few members, and those durable and of strong construction. It will be evident that such a motor can be manufactured very cheaply.

I am aware that motors somewhat similar to mine have been heretofore constructed; but none of these has all the good features possessed by my motor.

Having now fully set forth the construction of my motor, what I desire to claim and secure by Letters Patent of the United States is—

An electric motor or magneto-electric ma-

95

chine consisting of a magnet having polar
extensions between which the armature is ar-
ranged, with the part of said polar exten-
sions near the magnet and neutral point
5 fashioned into feet to support the motor, and
the horizontal coil mounted between the po-
lar extensions and attached thereto near the
feet, substantially as described.

In testimony whereof I affix my signature in
presence of two witnesses.

GEORGE W. MANSFIELD.

Witnesses:

CHAS. K. STEARNS,
G. R. BLAISDELL.