

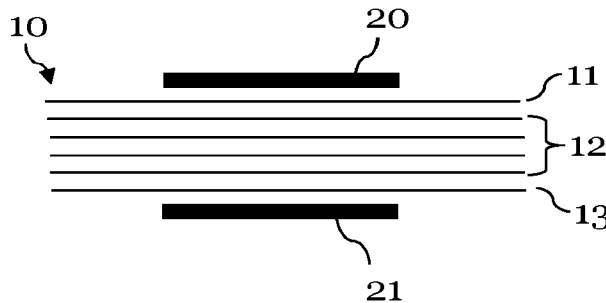

(86) Date de dépôt PCT/PCT Filing Date: 2017/12/29
 (87) Date publication PCT/PCT Publication Date: 2019/07/04
 (45) Date de délivrance/Issue Date: 2022/08/09
 (85) Entrée phase nationale/National Entry: 2020/05/28
 (86) N° demande PCT/PCT Application No.: EP 2017/084805
 (87) N° publication PCT/PCT Publication No.: 2019/129356

(51) Cl.Int./Int.Cl. *B32B 21/02* (2006.01),
B32B 21/06 (2006.01), *B32B 29/00* (2006.01),
B32B 3/06 (2006.01), *B32B 3/30* (2006.01),
B32B 37/10 (2006.01), *B32B 38/06* (2006.01),
B44C 1/24 (2006.01)
 (72) Inventeurs/Inventors:
 DOEHRING, RAINER, CH;
 PIOTROWSKI, DAWID, CH
 (73) Propriétaire/Owner:
 XYLO TECHNOLOGIES AG, CH
 (74) Agent: SMART & BIGGAR LLP

(54) Titre : STRATIFIE A STRUCTURE SYNCHRONE
 (54) Title: LAMINATE WITH SYNCHRONOUS STRUCTURE



(57) Abrégé/Abstract:

The present invention relates to a process for the manufacture of a laminate, in particular a continuously pressed laminate, CPL, which can be used, for example, as a surface laminate in the manufacture of worktops or floor panels. The process includes the provision of a finish foil and a support structure, as well as the pressing of the finish foil with the support structure in a CPL process.

(12) INTERNATIONAL APPLICATION PUBLISHED UNDER THE PATENT COOPERATION TREATY (PCT)

(19) World Intellectual Property
Organization
International Bureau



(10) International Publication Number
WO 2019/129356 A1

(43) International Publication Date
04 July 2019 (04.07.2019)

(51) International Patent Classification:

B32B 21/02 (2006.01) *B32B 3/30* (2006.01)
B32B 21/06 (2006.01) *B32B 37/10* (2006.01)
B32B 29/00 (2006.01) *B32B 38/06* (2006.01)
B32B 3/06 (2006.01) *B44C 1/24* (2006.01)

MC, MK, MT, NL, NO, PL, PT, RO, RS, SE, SI, SK, SM, TR), OAPI (BF, BJ, CF, CG, CI, CM, GA, GN, GQ, GW, KM, ML, MR, NE, SN, TD, TG).

Published:

— with international search report (Art. 21(3))

(21) International Application Number:

PCT/EP2017/084805

(22) International Filing Date:

29 December 2017 (29.12.2017)

(25) Filing Language:

English

(26) Publication Language:

English

(71) Applicant: **XYLO TECHNOLOGIES AG** [CH/CH];
Rütihofstr. 1, 9052 Niederteufen (CH).

(72) Inventors: **DOEHRING, Rainer**; Rütihofstr. 1, 9052
Niederteufen (CH). **PIOTROWSKI, Dawid**; Rütihofstr. 1,
9052 Niederteufen (CH).

(74) Agent: **MADER, Joachim**; BARDEHLE PAGENBERG
Partnerschaft mbB, Prinzregentenplatz 7, 81675 München
(DE).

(81) Designated States (*unless otherwise indicated, for every kind of national protection available*): AE, AG, AL, AM, AO, AT, AU, AZ, BA, BB, BG, BH, BN, BR, BW, BY, BZ, CA, CH, CL, CN, CO, CR, CU, CZ, DE, DJ, DK, DM, DO, DZ, EC, EE, EG, ES, FI, GB, GD, GE, GH, GM, GT, HN, HR, HU, ID, IL, IN, IR, IS, JO, JP, KE, KG, KH, KN, KP, KR, KW, KZ, LA, LC, LK, LR, LS, LU, LY, MA, MD, ME, MG, MK, MN, MW, MX, MY, MZ, NA, NG, NI, NO, NZ, OM, PA, PE, PG, PH, PL, PT, QA, RO, RS, RU, RW, SA, SC, SD, SE, SG, SK, SL, SM, ST, SV, SY, TH, TJ, TM, TN, TR, TT, TZ, UA, UG, US, UZ, VC, VN, ZA, ZM, ZW.

(84) Designated States (*unless otherwise indicated, for every kind of regional protection available*): ARIPO (BW, GH, GM, KE, LR, LS, MW, MZ, NA, RW, SD, SL, ST, SZ, TZ, UG, ZM, ZW), Eurasian (AM, AZ, BY, KG, KZ, RU, TJ, TM), European (AL, AT, BE, BG, CH, CY, CZ, DE, DK, EE, ES, FI, FR, GB, GR, HR, HU, IE, IS, IT, LT, LU, LV,

(54) Title: LAMINATE WITH SYNCHRONOUS STRUCTURE

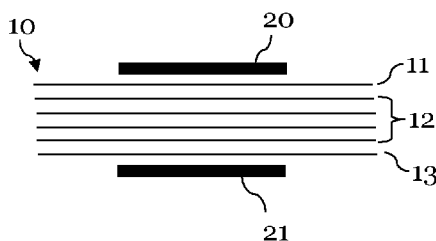

Fig. 1

(57) Abstract: The present invention relates to a process for the manufacture of a laminate, in particular a continuously pressed laminate, CPL, which can be used, for example, as a surface laminate in the manufacture of worktops or floor panels. The process includes the provision of a finish foil and a support structure, as well as the pressing of the finish foil with the support structure in a CPL process.



WO 2019/129356 A1

Laminate with Synchronous Structure

1. Field of the Invention

5

The present invention relates to a method for the manufacture of a laminate, in particular a continuously pressed laminate, a method for the manufacture of a panel, as well as a correspondingly manufactured laminate and panel.

2. Background of the Invention

10

State-of-the-art technology has produced a wide range of materials that can be used in the production of panels, such as wall, ceiling and flooring panels. For the production of such panels, a so-called finish foil can be applied to a carrier board made of e.g. MDF or HDF, for example in a coating process. The finish foil can ultimately form the surface of the resulting panel. A finish foil can be an impregnated and/or lacquered decorative paper. In the art, the carrier boards are typically MDF (medium density fibreboard) or HDF (high density fibreboard) boards.

15

Typically, such manufactured panels are not suitable for use as worktops, door or furniture panels, because the surface is not sufficiently wear resistant. This is particularly disadvantageous for use as a worktop, for example, which is exposed to a certain amount of material stress in daily use. A door or worktop made with such a panel thus exhibits high wear and tear on the surface when used as intended in everyday use, and is therefore worn out after a short period of time. As a result, the use of conventional finish foils for coating MDF or HDF boards is not suitable for normal and heavy-duty products such as worktops.

20

25

Furthermore, the surface of the conventional finish foils, and in particular their optical and/or haptic appearance, cannot be changed during the coating process for the production of the panel. As a result, the panel manufacturer is ultimately dependent on

30

the manufacturing process of the supplier of the finish foils in this respect, and has no or only little influence on the appearance of the finished product or panel.

When applying the finish foils to a carrier board, such as an MDF or HDF board, a further negative effect becomes apparent, which is noticeable in the unevenness of the surface of the resulting product or panel. Usually, conventional finish foils are glued onto the carrier boards with the aid of glue dissolved in water. Due to the moisture content of the glue, a so-called "orange peel" is formed on the carrier board, which results from the partial swelling of the fibres or chips of the carrier board (e. g. MDF or HDF). In connection with the low layer thickness of conventional finish foils, which is usually less than 0.1 mm, this leads to a very uneven surface of the final product.

One object of the present invention is therefore to at least partially overcome the disadvantages mentioned above. One of the particular objects of this invention is to provide a process that enables the production of more resistant or wear-resistant laminates or panels, for example for use as worktops or floor panels. Furthermore, a possibility is provided to influence the appearance of the finished product, laminate or panel.

These and other objects which will be noticed when reading the following description, or which can be recognised by the skilled person, may be solved in accordance with the subject matter disclosed herein, in particular by a process for the manufacture of a laminate as disclosed herein, a laminate as disclosed herein, a panel as disclosed herein, and a process for the manufacture of a panel as disclosed herein.

3. Detailed Description of the Invention

The present invention concerns a method for the production of a laminate, and in particular a continuously pressed laminate. Such a continuously pressed laminate is also known as CPL (continuous pressure laminate). This is a laminate produced in a continuous process from two or more layers. The laminate can be produced in the form of panels or as rolled goods, and can then be used, for example, to coat surfaces for the manufacture of a panel. In the following the terms "CPL", "continuously pressed

laminated" and "CPL laminated" are used synonymously. The synonymous use of these terms does not imply any additional restriction of the individual terms with regard to the hardness or form of the material, for example.

5 The process involves the provision of a finish foil. The finish foil can also be denoted a top layer. The finish foil preferably has a thickness of 0.05 mm to 0.5 mm, further preferably between 0.06 mm and 0.3 mm, further preferably between 0.07 mm and 0.2 mm, further preferably between 0.08 mm and 0.15 mm, and most preferably between 0.09 mm and 0.1 mm. In particular, the thickness of the finish foil is preferably less
10 than 0.1 mm. In one form of the invention, a conventional finish foil can be used.

The method further comprises providing a support structure, wherein the support structure is provided with a phenolic resin. The support structure can comprise or consist of several individual layers. The support structure can include one or more
15 paper layers in particular. The paper layers can be available as cardboard layers. One or all of these layers preferably comprise the phenolic resin. The support structure preferably has a thickness from 0.1 mm to 2 mm, further preferably from 0.2 mm to 1.5 mm, further preferably from 0.3 mm to 1.2 mm, further preferably from 0.4 mm to 1.0 mm, and further preferably from 0.5 mm to 0.8 mm.

20 The process also includes pressing the provided finish foil with the support structure in a CPL process. In a CPL process, for example, the layers can be pressed in a continuous process into a kind of endless plate, by using e.g. a double-sided heated double-belt press. The double-belt press can comprise structural belts (i.e. belts with a
25 structured/embossed surface). The pressing pressure can be lower than in the production of so-called HPL boards (High Pressure Laminate).

By combining a finish foil and the support structure with phenolic resin, it is advantageously possible to produce a material or laminate that is far superior to other
30 materials in terms of its wear resistance. The resulting material or laminate thus allows, for example, the production of panels with a very wide range of applications. Compared to conventional finish foils, the resulting material or laminate is characterized by a higher layer thickness, which ultimately results in increased wear resistance. This means that the laminate can be used as a surface material for the manufacture of

products, such as worktops, which therefore show only minor signs of wear and tear even under normal everyday use.

5 The resulting CPL laminate preferably has a thickness of 0.1 mm to 2 mm, further preferably from 0.2 mm to 1.5 mm, further preferably from 0.3 to 1.2 mm, further preferably from 0.4 mm to 1.0 mm, and further preferably from 0.5 mm to 0.8 mm. The resulting laminate is therefore characterised by a thickness that is preferably substantially larger than that of the finish foil. However, other thicknesses are also possible. Furthermore, the laminate can also be provided with an overlay film in certain
10 designs, e. g. to increase the light-, moisture- or heat-resistance, whereby the finish foil is preferably arranged between such an overlay film and the support structure. The laminate is preferably sanded on one side.

The finish foil can be a commercial finish foil, which can have arbitrary structures. For
15 example, it can have a super-matt surface finish. Preferably, the finish foil is provided with a decorative pattern and a three-dimensional structure. The finish foil is preferably printed with the decorative pattern and varnished in such a way that a synchronous structure corresponding to the print pattern is created. Preferably, the finish foil is then hardened by means of electron beam radiation. Thus, the surface of
20 the finish foil can be provided with a (haptic) structure that is spatially related to the print pattern. Such a structure is also called synchronous pore in the art. Thus, the three-dimensional structure is preferably synchronized with the decorative pattern. In particular, the decorative pattern preferably imitates a wooden surface. The three-dimensional structure thereby also imitates a wood surface. The surface of the resulting
25 laminate thus looks and feels like wood. On a printed knothole, for example, the generated (surface) structure would contain a round or oval haptic structure at the place of the printed knothole. The difference between the optical pattern and the haptic structure on the resulting laminate is preferably less than 3 mm, preferably less than 2 mm, preferably less than 1 mm, preferably less than 0.5 mm, preferably less than 0.2
30 mm, and preferably less than 0.1 mm. Most preferably, there is no deviation. As a result, a laminate can be produced where there is no displacement between the printed image and the embossing or structure. The surface structure of the finished laminate matches perfectly with the printed image or pattern, for example, for a real "wood impression" of the laminate.

Preferably, pressing is carried out against an embossing structure provided in the CPL process. Thus, for example, an embossing structure can be provided, which is pressed together with the finish foil and the support structure. The embossing structure can be provided in the CPL process by means of structural belts of the double-belt press. In particular, the embossing structure is preferably a textured press ribbon or structural belt, a textured paper, or a textured press plate. For example, the embossing structure may have been prepared by an etching process. The embossing structure can be provided with a predetermined degree of gloss. Thus, for example, the gloss level of the resulting laminate can be changed by 3 gloss levels. The degree of gloss and thus the appearance of the resulting surface can be significantly influenced by pressing the finish foil with the support structure against the embossing structure. The manufacturer of the laminate is therefore no longer completely dependent on the supplier of the finish foil, but can change its appearance during the production of the laminate. This also makes it possible to adjust the structure, pattern and gloss level of the laminate as synchronously as possible, so that there is no or only a slight deviation between structure, pattern and gloss level.

The phenolic resin is preferably a phenol-formaldehyde resin. The phenolic resin preferably comprises a curing agent, so that the phenolic resin has a turbidity time at 100°C of 3.0 to 7.0 minutes, further preferably from 3.5 to 6.5 minutes, further preferably from 4.0 to 5.5 minutes, further preferably from 4.45 to 5.20 minutes and most preferably from 4.7 to 4.9 minutes. This allows the reactivity of the phenolic resin to be adjusted accordingly, to achieve optimum curing and resistance of the laminate.

The resin content in the support structure is preferably 70 to 99% by weight, further preferably 80 to 95% by weight, and most preferably 87 to 93% by weight. The weight is the overall weight of the support structure. Thereby, a wear-resistant laminate can be produced.

The provision of the support structure preferably involves impregnating the support structure with phenolic resin. The support structure is preferably impregnated with the phenolic resin. The volatile components of the impregnate are preferably between 6.5 %

and 9.0 % after appropriate drying, and preferably between 7.0 % and 8.5 %, and most preferably between 7.5 % and 8.0 %. This enables optimal curing of the laminate.

5 Preferably, pressing is carried out in the CPL process at a pressure of 10 bar to 100 bar, further preferably from 15 bar to 80 bar, further preferably from 20 bar to 60 bar, further preferably from 25 bar to 45 bar and most preferably from 30 bar to 35 bar.

10 Preferably, pressing is carried out in the CPL process at a temperature of 120 °C to 200 °C, further preferably from 140 °C to 180 °C, further preferably 150 °C to 170 °C, and most preferably at about 165 °C.

15 Furthermore, the invention relates to a laminate which is manufactured according to one of the above-mentioned methods. The advantage of this laminate is that it has a greater layer thickness than standard commercial finish foils, which results in high wear resistance. Thus, the laminate preferably has a thickness of 0.1 mm to 2 mm, further preferably from 0.2 mm to 1.5 mm, further preferably from 0.3 to 1.2 mm, further preferably from 0.4 mm to 1.0 mm, and further preferably from 0.5 mm to 0.8 mm. Furthermore, the colour or pattern, structure and/or gloss level of the laminate should preferably be synchronized as described above.

20 Furthermore, the invention relates to a laminate, and in particular a continuously pressed laminate. This laminate has a finish foil and a support structure, whereby the support structure is provided with a phenolic resin. The finish foil is pressed with the support structure. This laminate also has thicknesses as described above and offers a high wear resistance.

30 Furthermore, the invention relates to a panel, and in particular a wall, ceiling or floor panel. The panel can also be designed as a door or furniture panel and can be used, for example, as a vertical surface in furniture. The panel can also be designed as a worktop. The panel has a carrier board and a laminate in accordance with the above embodiments. For example, a HDF, MDF or chipboard board can be used as a carrier board. The resulting panel has a high surface resistance and thus a long service life. In particular, the use of the laminate described above results in a flat and even surface of

the panel, especially in comparison with panels where conventional finish foils are pressed directly onto the carrier board. The "orange peel" effect is avoided.

The panel is preferably designed as a floor panel. The panel preferably has coupling elements, which are designed for positive coupling with at least one further panel (of
5 similar or identical design), whereby the coupling takes place without glue. Due to the improved surface properties, it is therefore advantageously possible to produce an even and wear-resistant floor covering.

Furthermore, the invention concerns a method for the production of a panel, in particular a panel as described above. The method comprises the provision of a
10 laminate as described above, and the provision of a carrier board which is in particular a HDF, MDF or chipboard board. The process also includes applying, and in particular laminating, the laminate to the carrier board.

Furthermore, the present invention concerns the use of a laminate described above as a surface for the manufacture of worktops or vertical surfaces such as furniture fronts
15 or doors. Due to its high wear resistance, this laminate can be used, for example, on worktops in contrast to commercial finish foils, which are unsuitable for such an application. Production in a CPL process also results in a very smooth and even surface of the final material.

Another aspect of the present disclosure relates to a method for producing a
20 continuously pressed laminate, CPL, comprising the following steps: providing a finish foil, wherein the finish foil is provided with a decorative pattern and a three-dimensional structure, wherein the structure is synchronized with the decorative pattern, wherein the pattern imitates a wooden surface; providing a dry sheet, providing a support structure, wherein the support structure is provided with a
25 phenolic resin and wherein the support structure is provided between the finish foil and the dry sheet; and pressing of the finish foil with the support structure in a CPL process, wherein the phenolic resin is a phenol-formaldehyde resin; wherein the resin content in the support structure is 70 to 99% by weight; wherein providing the support structure comprises impregnating the support structure with phenolic resin;
30 wherein volatile matter after drying of the impregnate are in the range between 6.5% and 9.0%, wherein the pressing comprises compressing the finish foil with the

support structure and the dry sheet in the CPL process, wherein the pressing is carried out against an embossing structure provided in the CPL process.

A further aspect of the present disclosure relates to a continuously pressed laminate, CPL, comprising: a finish foil; and a dry sheet, and a support structure, wherein the support structure is provided with a phenolic resin; wherein the support structure is provided between the finish foil and the dry sheet; wherein the finish foil is provided with a decorative pattern and a three-dimensional structure, wherein the structure is synchronized with the decorative pattern, wherein the pattern imitates a wooden surface; wherein the finish foil is pressed with the support structure and the dry sheet to form the laminate, and the laminate having a thickness of from 0.1 to 2.0 mm.

A panel according to yet another aspect of the present disclosure comprises a carrier board and a laminate as disclosed herein attached to the carrier board.

Another aspect of the present disclosure relates to a process for the manufacture of a panel as disclosed herein, the process comprising: providing a laminate as disclosed herein; providing a carrier board; and applying the laminate onto the carrier board.

The increased wear resistance of one of the laminates or panels described above or a laminate or panel manufactured according to the processes described above can be characterised in accordance with EN 438. In this case, the laminate preferably exhibits ball impact values with small balls of at least 5 N, further preferably of at least 7 N, further preferably of at least 8 N, and further preferably of at least 9 N. Similarly, the laminate can preferably exhibit ball impact values with a shock load with small balls of at most 15 N, further preferably of at most 12 N. In addition, the laminate can exhibit ball impact values with small balls of at most 15 N, further preferably of at most 12 N. The panel shall preferably have ball impact values for a shock load with small balls of at least 15 N, further preferably at least 17 N, further preferably at least 19 N, further preferably at least 21 N, and further preferably at least 22 N. Likewise, the laminate can

preferably exhibit ball impact values with a maximum impact load of 30 N for small balls, and preferably a maximum of 25 N.

4. Description of Preferred Embodiments

5

In the following, the present invention is described in more detail with reference to the enclosed figures. Same elements have the same reference numbers.

Figure 1 schematically illustrates the method for the manufacture of a continuously pressed laminate according to an embodiment of the invention; and

10

Figure 2 schematically shows the composition of a panel according to another embodiment of the invention.

15 Figure 1 shows a process for the production of a continuously pressed laminate 10 in accordance with an embodiment of the present invention. A double-belt press with two structural belts 20, 21 arranged opposite each other is provided. These structural belts 20, 21 guide the individual layers in the CPL process in order to ultimately form the CPL laminate or laminate 10. Structural belts 20, 21 can include a structured belt (made of etched and chrome-plated steel) or a texturing paper (painted and embossed paper) or similar.

20

The materials or layers that are fed to the structural belts 20,21 comprise a finish foil 11, a support structure 12, and in the shown embodiment also a dry sheet 13 made of sodium kraft paper. The support structure 12 is arranged between the finish foil 11 and the dry sheet 13.

25

In the embodiment shown in Figure 1, the support structure 12 comprises four layers of individual layers of paper. However, the skilled person understands that in other 30 embodiments more or less paper layers or other materials can be used to form the support structure 12. The paper layers of support structure 12 comprise phenolic resin. For this purpose, the individual paper layers were impregnated accordingly. The decisive factor is the reactivity of the phenolic resin, which is set for impregnation within a tolerance range of preferably 4.45 to 5.20 minutes (clouding time measured at

30

100°C) per hardener. Furthermore, the resin content in the impregnation is set between 87% and 93% (based on the paper mass). The volatile components after drying of the impregnate are kept within a tolerance of 7.5 % to 8.0 %.

5 Finish foil 11 has a printed image that imitates a wooden surface. Furthermore, the finish foil 11 has a (haptic) structure which is synchronous to the printed image. This structure thus matches the printed image, so that in the finished laminate 10 the haptic impression matches the optical impression. In another version, the finish foil 11 can also have a different surface finish, such as a super-matt surface finish.

10

Finish foil 11, support structure 12 and dry sheet 13 are pressed in a CPL process using structural belts 20, 21. This is done at a pressure of 35 to 50 bar and a temperature of 165 °C.

15

In a particular embodiment of the present invention, at least one of the structural belts 20, 21 is provided with a textured surface. This textured surface gives the surface of the resulting laminate a corresponding surface finish, whereby the gloss level of the finished laminate can be adjusted or changed. In another embodiment, the finish foil 11 can also be pressed against a structural band or a texturing paper in the CPL process to influence the gloss level and thus the appearance of the resulting surface. Thus it is advantageous to obtain a synchronization of the print image, structure/pores and the gloss level of the finished laminate. Summer rings in the print image can show a higher degree of gloss than rougher winter rings in the print image.

20

25

Figure 2 shows a panel 30 in accordance with another embodiment of the present invention. This panel consists of a carrier board 40 made of MDF or HDF. A CPL laminate or laminate 10 is applied or laminated onto this carrier board 40. This laminate 10 is preferably a laminate produced by means of a manufacturing method as described above with reference to Figure 1. Instead of a standard commercial finish foil, laminate 10 is thus applied to the carrier board 40. Due to the higher wear resistance of laminate 10, the surface of the finished panel 30 is also more resistant. This means that the panel 30 can be used advantageously not only as a floor, ceiling or wall panel, but also as a worktop or as a vertical surface, such as in furniture fronts or doors.

30

Furthermore, the surface of the panel 30 has a uniform and smooth structure, which

results from the manufacturing process and also from the increased layer thickness of laminate 10 compared to conventional finish foils 11.

Such a laminate 10 produced in accordance with the present invention preferably has a
5 ball impact strength of 9 N under impact stress with small balls, while a
correspondingly manufactured panel has a value of 22 N.

In preferred embodiments, the panel 30 can be used as a floor panel. For this purpose,
panel 30 comprises appropriate coupling elements on its sides, which allow a positive
10 coupling of such panels 30 with other panels, without the use of glue. Due to the
advantageous surface quality of the panels 30, these panels are very well suited for
interconnection.

15 Reference numbers:

10 Laminate
11 Finish foil
12 Support structure
13 Dry sheet
20 20,21 Structural belts
30 Panel
40 Carrier board

CLAIMS:

1. A method for producing a continuously pressed laminate, CPL, comprising the following steps:

5 providing a finish foil, wherein the finish foil is provided with a decorative pattern and a three-dimensional structure, wherein the structure is synchronized with the decorative pattern, wherein the pattern imitates a wooden surface;

providing a dry sheet,

10 providing a support structure, wherein the support structure is provided with a phenolic resin and wherein the support structure is provided between the finish foil and the dry sheet; and

pressing of the finish foil with the support structure in a CPL process,

wherein the phenolic resin is a phenol-formaldehyde resin;

wherein the resin content in the support structure is 70 to 99% by weight;

15 wherein providing the support structure comprises impregnating the support structure with phenolic resin;

wherein volatile matter after drying of the impregnate are in the range between 6.5% and 9.0%,

wherein the pressing comprises compressing the finish foil with the support structure and the dry sheet in the CPL process,

20 wherein the pressing is carried out against an embossing structure provided in the CPL process.

2. The method according to claim 1, wherein the embossing structure is a textured press belt, or a textured paper, or a textured press plate.

3. The method according to Claim 1 or 2, wherein the resin content in the 25 support structure is 80 to 95% by weight.

4. The method according to Claim 1 or 2, wherein the resin content in the support structure is 87 to 93% by weight.
5. The method according to any one of Claims 1 to 4, wherein the support structure comprises one or more layers of paper.
- 5 6. The method according to claim 1, wherein volatile matter after drying of the impregnate are in the range between 7.0% and 8.5%.
7. The method according to claim 1, wherein volatile matter after drying of the impregnate are in the range between 7.5% and 8.0%.
8. The method according to any one of Claims 1 to 7, wherein the pressing
10 takes place at a pressure of 10 to 100 bar.
9. The method according to any one of Claims 1 to 7, wherein the pressing takes place at a pressure of from 15 to 80 bar.
10. The method according to any one of Claims 1 to 7, wherein the pressing takes place at a pressure of from 20 to 60 bar.
- 15 11. The method according to any one of Claims 1 to 7, wherein the pressing takes place at a pressure of from 25 to 45 bar.
12. The method according to any one of Claims 1 to 7, wherein the pressing takes place at a pressure of from 30 to 35 bar.
13. The method according to any one of Claims 1 to 12, wherein the pressing is
20 carried out at a temperature of 120 to 200 degrees Celsius.
14. The method according to any one of Claims 1 to 12, wherein the pressing is carried out at a temperature of 140 to 180 degrees Celsius.
15. The method according to any one of Claims 1 to 12, wherein the pressing is carried out at a temperature of 150 to 170 degrees Celsius.
- 25 16. The method according to any one of Claims 1 to 12, wherein the pressing is carried out at a temperature of about 165 degrees Celsius.

17. The method according to any one of Claims 1 to 16, wherein the pressing is carried out by means of a double-belt press.
18. The method according to Claim 17, the double-belt press comprising two structural belts.
- 5 19. A continuously pressed laminate, CPL, comprising:
- a finish foil; and
- a dry sheet, and
- a support structure, wherein the support structure is provided with a phenolic resin;
- 10 wherein the support structure is provided between the finish foil and the dry sheet;
- wherein the finish foil is provided with a decorative pattern and a three-dimensional structure, wherein the structure is synchronized with the decorative pattern, wherein the pattern imitates a wooden surface;
- 15 wherein the finish foil is pressed with the support structure and the dry sheet to form the laminate, and
- the laminate having a thickness of from 0.1 to 2.0 mm.
20. The laminate of claim 19, the laminate having a thickness of from 0.2 to 1.5 mm.
- 20 21. The laminate of claim 19, the laminate having a thickness of from 0.3 to 1.2 mm.
22. The laminate of claim 19, the laminate having a thickness of from 0.4 to 1.0 mm.
23. The laminate of claim 19, the laminate having a thickness of from 0.5 to
- 25 0.8 mm.

24. The laminate according to any one of Claims 19 to 23, wherein the laminate has ball impact values according to EN 438 at a shock load with balls of at least 5 N.
25. The laminate according to any one of Claims 19 to 23, wherein the laminate
5 has ball impact values according to EN 438 at a shock load with balls of at least 7 N.
26. The laminate according to any one of Claims 19 to 23, wherein the laminate has ball impact values according to EN 438 at a shock load with balls of at least 8 N.
- 10 27. The laminate according to any one of Claims 19 to 23, wherein the laminate has ball impact values according to EN 438 at a shock load with balls of at least 9 N.
28. The laminate according to any one of Claims 19 to 27, wherein the laminate has ball impact values according to EN 438 at a shock load with balls of not more
15 than 15 N.
29. The laminate according to any one of Claims 19 to 27, wherein the laminate has ball impact values according to EN 438 at a shock load with balls of not more than 12 N.
30. A panel comprising a carrier board and a laminate in accordance with any
20 one of Claims 19 to 29 attached to the carrier board.
31. The panel according to claim 30, wherein the panel comprises a wall panel, a ceiling panel, a floor panel, a door panel, a furniture panel, or a worktop.
32. The panel according to claim 30, the panel being designed as a floor panel, comprising coupling elements adapted for positive coupling without glue to
25 another panel.
33. The panel according to any one of claims 30 to 32, wherein the panel has ball impact values according to EN 438 at a shock load with balls of at least 15 N.

34. The panel according to any one of claims 30 to 32, wherein the panel has ball impact values according to EN 438 at a shock load with balls of at least 17 N.
35. The panel according to any one of claims 30 to 32, wherein the panel has ball impact values according to EN 438 at a shock load with balls of at least 19 N.
- 5 36. The panel according to any one of claims 30 to 32, wherein the panel has ball impact values according to EN 438 at a shock load with balls of at least 21 N.
37. The panel according to any one of claims 30 to 32, wherein the panel has ball impact values according to EN 438 at a shock load with balls of at least 22 N.
38. The panel according to any one of Claims 30 to 37, wherein the panel has
10 ball impact values according to EN 438 at a shock load with balls of maximum 30 N.
39. The panel according to any one of Claims 30 to 37, wherein the panel has ball impact values according to EN 438 at a shock load with balls of maximum 25 N.
- 15 40. A process for the manufacture of the panel according to any one of Claims 30 to 39, the process comprising:
- providing a laminate according to any one of Claims 19 to 29;
 - providing a carrier board; and
 - applying the laminate onto the carrier board.
- 20 41. The process according to Claim 40, wherein providing a carrier board comprises providing HDF, MDF or particle board.
42. The process according to Claim 40 or 41, wherein applying the laminate onto the carrier board comprises laminating the laminate onto the carrier board.

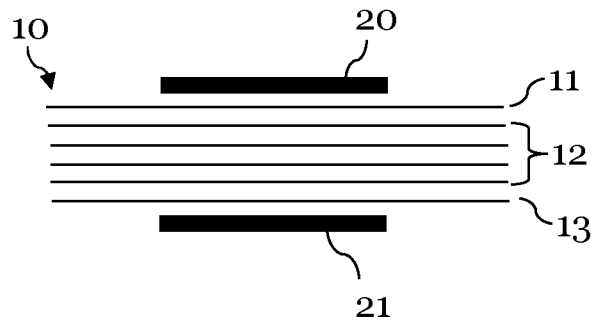

Fig. 1

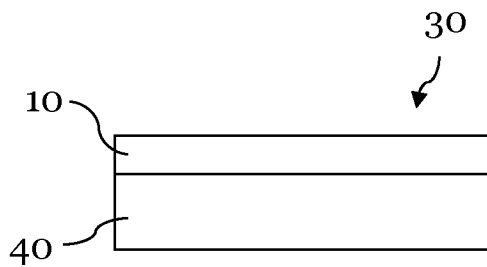

Fig. 2

