

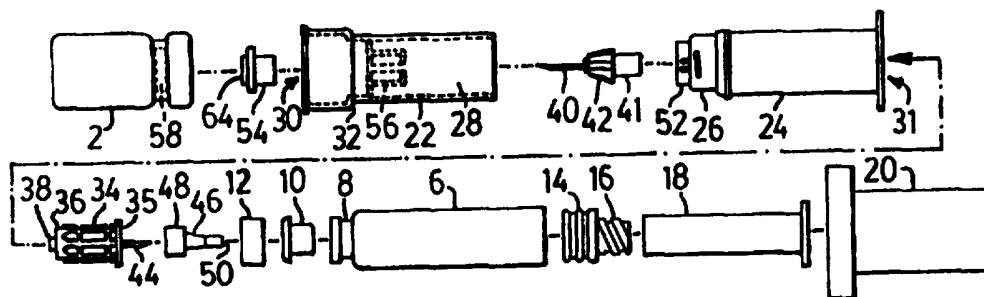

INTERNATIONAL APPLICATION PUBLISHED UNDER THE PATENT COOPERATION TREATY (PCT)

<p>(51) International Patent Classification ⁶ : A61J 1/00</p>	<p>A1</p>	<p>(11) International Publication Number: WO 97/25015</p> <p>(43) International Publication Date: 17 July 1997 (17.07.97)</p>
<p>(21) International Application Number: PCT/CA97/00017</p> <p>(22) International Filing Date: 10 January 1997 (10.01.97)</p> <p>(30) Priority Data: 08/584,049 11 January 1996 (11.01.96) US</p> <p>(60) Parent Application or Grant (63) Related by Continuation US 08/584,049 (CIP) Filed on 11 January 1996 (11.01.96)</p> <p>(71) Applicant (for all designated States except US): DUOJECT MEDICAL SYSTEMS INC. [CA/CA]; 305 Knowlton Road, Lac Brome, Quebec JOE 1V0 (CA).</p> <p>(72) Inventor; and (75) Inventor/Applicant (for US only): REYNOLDS, David, L. [CA/CA]; 305 Knowlton Road, Lac Brome, Quebec JOE 1V0 (CA).</p> <p>(74) Agent: PARSONS, Richard, A., R.; Ridout & Maybee, Suite 2400, One Queen Street East, Toronto, Ontario M5C 3B1 (CA).</p>		<p>(81) Designated States: AL, AM, AT, AU, AZ, BA, BB, BG, BR, BY, CA, CH, CN, CU, CZ, DE, DK, EE, ES, FI, GB, GE, HU, IL, IS, JP, KE, KG, KP, KR, KZ, LC, LK, LR, LS, LT, LU, LV, MD, MG, MK, MN, MW, MX, NO, NZ, PL, PT, RO, RU, SD, SE, SG, SI, SK, TJ, TM, TR, TT, UA, UG, US, UZ, VN, ARIPO patent (KE, LS, MW, SD, SZ, UG), Eurasian patent (AM, AZ, BY, KG, KZ, MD, RU, TJ, TM), European patent (AT, BE, CH, DE, DK, ES, FI, FR, GB, GR, IE, IT, LU, MC, NL, PT, SE), OAPI patent (BF, BJ, CF, CG, CI, CM, GA, GN, ML, MR, NE, SN, TD, TG).</p> <p>Published <i>With international search report. Before the expiration of the time limit for amending the claims and to be republished in the event of the receipt of amendments.</i></p>

(54) Title: DELIVERY SYSTEM FOR PHARMACEUTICALS PACKED IN PHARMACEUTICAL VIALS



(57) Abstract

A system is provided for providing syringes filled with pharmaceuticals whose components must be stored separately, using an active ingredient in a pharmaceutical vial (2), a diluent in a protosyringe such as a bottomless vial (4) or a cartridge, and a combiner assembly which enables the content of the pharmaceutical vial to be transferred into the protosyringe and converts it into a ready-to-use syringe on activation. The combined assembly included a tubular body (22, 24) having recesses (30, 31) at opposite ends for receiving capped ends of the vial (2) and the protosyringe (4), and a hub (34) and needle (40, 44) assembly between penetrable sheaths or shields (46, 64) which acts on activation of the assembly to enable the transfer and conversion referred to above. Components of the system may also be used to convert protosyringes and pharmaceutical vials containing pharmaceuticals into delivery systems.

FOR THE PURPOSES OF INFORMATION ONLY

Codes used to identify States party to the PCT on the front pages of pamphlets publishing international applications under the PCT.

AM	Armenia	GB	United Kingdom	MW	Malawi
AT	Austria	GE	Georgia	MX	Mexico
AU	Australia	GN	Guinea	NE	Niger
BB	Barbados	GR	Greece	NL	Netherlands
BE	Belgium	HU	Hungary	NO	Norway
BF	Burkina Faso	IE	Ireland	NZ	New Zealand
BG	Bulgaria	IT	Italy	PL	Poland
BJ	Benin	JP	Japan	PT	Portugal
BR	Brazil	KE	Kenya	RO	Romania
BY	Belarus	KG	Kyrgyzstan	RU	Russian Federation
CA	Canada	KP	Democratic People's Republic of Korea	SD	Sudan
CF	Central African Republic	KR	Republic of Korea	SE	Sweden
CG	Congo	KZ	Kazakhstan	SG	Singapore
CH	Switzerland	LI	Liechtenstein	SI	Slovenia
CI	Côte d'Ivoire	LK	Sri Lanka	SK	Slovakia
CM	Cameroon	LR	Liberia	SN	Senegal
CN	China	LT	Lithuania	SZ	Swaziland
CS	Czechoslovakia	LU	Luxembourg	TD	Chad
CZ	Czech Republic	LV	Latvia	TG	Togo
DE	Germany	MC	Monaco	TJ	Tajikistan
DK	Denmark	MD	Republic of Moldova	TT	Trinidad and Tobago
EE	Estonia	MG	Madagascar	UA	Ukraine
ES	Spain	ML	Mali	UG	Uganda
FI	Finland	MN	Mongolia	US	United States of America
FR	France	MR	Mauritania	UZ	Uzbekistan
GA	Gabon			VN	Viet Nam

DELIVERY SYSTEM FOR PHARMACEUTICALS PACKED IN
PHARMACEUTICAL VIALS

5 This invention relates to delivery systems for multiple
component pharmaceutical preparations.

10 Many pharmaceutical preparations must be distributed as
two or more separate components which can only be combined
shortly before administration of the preparation, usually
because the combined preparation is subject to rapid
deterioration or otherwise unstable, and the components are
only stable when stored separately. Typically at least one
component of such a preparation is a liquid which acts as a
solvent, diluent or carrier for the other component.

15

20 Traditionally such preparations have been prepared
shortly before administration by taking one component
packaged in a conventional pharmaceutical vial having a neck
closed by a penetrable elastomeric stopper secured to a neck
of the vial by a cap, taking a second liquid component in a
hypodermic syringe, injecting the second component into the
vial through the stopper, swilling the vial impaled on the
syringe to dissolve, dilute or suspend the first component
in the second component, and aspirating the combined
25 components back into the syringe by withdrawing its plunger.
This procedure requires a degree of dexterity, is subject to
the errors commonly associated with manual on-site
preparation of pharmaceuticals, and may compromise
sterility. If a third component is used, the procedure must
30 be repeated.

35 In endeavours to overcome these problems, many
proposals have been made for systems to provide prepackaged
two component pharmaceuticals, but these tend to suffer from
one or more problems of their own such as complex and
expensive structure requirements for specialized filling

equipment, complex manipulation at the time of use, and often most serious of all, a heavy burden in time and expense in obtaining regulatory approval for a new product.

5 U.S. Patent No. 3,872,867 (Killinger) utilizes a tubular assembly incorporating a double ended cannula, into which two pharmaceutical vials are pressed in order to combine components in the two vials. The system requires that one of the vials is under vacuum at pressure, and
10 merely results in a vial containing the combined product, which must still be transferred to a syringe for administration.

U.S. Patent No. 3,563,373 (Paulson) discloses an
15 arrangement utilizing two cartridges in tandem for packaging a two component pharmaceutical, utilizing an intermediate assembly incorporating a double ended needle, which penetrates the piston of one cartridge and neck stopper of the other. The arrangement cannot utilize a standard
20 pharmaceutical vial.

U.S. Patent No. 4,060,082 (Lindberg) also requires two
syringes in tandem for combining a two component
pharmaceutical, as well as specialized auxiliary pistons in
25 the syringes.

U.S. Patent No. 4,583,971 (Bocquet et al) discloses
apparatus for transferring liquid through a cannula from a
flexible container to dissolve a pharmaceutical, and
30 returning the solution to the flexible container. The system is dependent upon manipulation of a tangible closure through the flexible container and could not be used to transfer liquid from a syringe to a pharmaceutical vial and back again.

U.S. Patent No. 5,171,214 (Kolber et al) discloses a combination of a vial assembly, a syringe assembly, and an adapter for attaching the vial assembly to the syringe assembly so that a liquid constituent may be transferred from the syringe to the vial and the admixed compounds returned to the syringe. A special vial and special syringe are required, and indeed the system is predicated upon the use of a proprietary vial assembly.

An object of the present invention is to provide a delivery system for two component pharmaceuticals which is economical to manufacture, easy to manipulate, and can minimize regulatory burdens.

SUMMARY OF THE INVENTION

According to the invention, there is provided an activation assembly for a protosyringe or pharmaceutical vial having a penetrable septum, comprising a tubular socket having a first portion extending from an open end to receive in said open end at least a portion of a protosyringe or pharmaceutical vial presenting the penetrable septum, a second portion extending from the first portion to an opposite end of the socket, a guide at said opposite end of the socket, and a hub assembly movable within said guide for movement axially of said second portion of the socket, the hub assembly having a cannula extending into the socket at one end thereof from a liquid delivery conduit at the other end thereof, and a penetrable sheath enclosing the cannula, the hub and the protosyringe or pharmaceutical vial being relatively movable within the socket between a position in which the shield contacts the penetrable septum in a zone coaxial with the cannula, and a position in which the cannula penetrates both the shield and the septum.

The invention extends to an assembly for preparing a prefilled syringe from separately prepackaged components of a multi-component pharmaceutical preparation, the assembly comprising a two part tubular body; the body defining in a first part a first cylindrical recess at one end of a diameter to receive, as a sliding fit, a capped end of a protosyringe at which end a cap retains a penetrable closure on a neck of the protosyringe, as well as a substantial portion of a cylindrical body of the protosyringe, the cylindrical body containing a first, liquid component of the pharmaceutical preparation, retained in the body by a piston within the cylindrical body and forming a hermetic sliding seal therewith; a second cylindrical recess defined in the other end of the tubular body by a second detachable part to receive as a press fit a cap securing a penetrable closure at the neck of a pharmaceutical vial containing a second component of the pharmaceutical preparation; the tubular body defining in said first part a passage connecting the cylindrical recesses; a hub movable longitudinally of the tubular body within the passage; cannulas extending longitudinally of the tubular body from said hub to distal ends in opposite directions and communicating with one another through said hub; penetrable shield members covering the distal ends of the cannulas and located to contact penetrable closures of a protosyringe and of a pharmaceutical vial inserted in the cylindrical recesses; and a hollow cylindrical overcap concentric with the hub assembly and located within the tubular body in the first cylindrical recess, the overcap being connected to the hub to limit movement of the latter into the passage; the depth of the cylindrical recess, the length of the passage connecting the recesses, the extent of the cannulas from the hub, and the location of the overcap in the first cylindrical recess, being such that upon a protosyringe received in the first cylindrical recess and a vial received

in the second recess being driven towards each other, the overcap is driven onto the cap of the protosyringe and the hub moves longitudinally so that the cannulas penetrate both penetrable sealing members and the penetrable closures of the protosyringe and vial respectively to place the protosyringe and vial in fluid communication through the cannulas.

Two terms used in the preceding paragraph and elsewhere in this specification and the appended claims require mention. A 'protosyringe' is an assembly intended to form the basis of a prefilled syringe but requiring the addition of components to form a complete syringe. At minimum, it includes a cylindrical body containing at least a component of a pharmaceutical product, the body being closed at one, necked end by a cap securing a penetrable closure and at an opposite open end by a piston connected to or provided with means for connection to an activating plunger. Protosyringes include bottomless vials as described in my U.S. Patent No. 5,364,369; cartridges; and prefilled syringes requiring at least addition of an overcap as defined below and introduction of a further component of the pharmaceutical product to provide a ready to use syringe. An 'overcap' is a cap adapted to be lodged on the cap of a protosyringe and providing means for supporting a needle or other instrumentality through which contents of a syringe formed from the protosyringe may be discharged. In some instances, a complete prefilled syringe itself may be used as a protosyringe if it has a luer connection closed by a cap of penetrable material over which an overcap may be received.

The invention also extends to the combination of such an assembly with a protosyringe and/or pharmaceutical vials already engaged in their associated cylindrical recesses.

If the protosyringe is already engaged in the first cylindrical recess, its free end may be covered by a removable cap to prevent accidental projection into the cylindrical bottom resulting in premature actuation of the assembly. When a protosyringe or vial is preengaged in its cylindrical recess, the associated sealing member in the assembly is in resilient contact with the penetrable closure of the vial in areas concentric with the cannula so as to help maintain sterility of areas of the sealing members and closures intended to be penetrated by the cannula.

The hub assembly and a modified overcap may also be utilized in conjunction with a protosyringe or pharmaceutical vial to provide alternative delivery systems for pharmaceuticals contained in the protosyringe or vial.

Further features of the invention will be apparent from the following description of embodiments of the invention.

20

IN THE DRAWINGS

Figure 1 is an exploded view of the components of an assembly according to the invention, including both a protosyringe, in this case a bottomless vial, and a pharmaceutical vial;

25

Figure 2 illustrates an assembly according to the invention, including a bottomless vial, as it might be shipped;

Figure 3 illustrates a similar assembly, but further including a pharmaceutical vial, ready for activation;

30

Figure 4 illustrates in part sectional view components of an assembly according to Figure 3, but with upper components removed for clarity;

35

Figure 5 is a similar view to Figure 4, but showing the illustrated components in the relationship which they assume after activation of the assembly in order to prepare a

completed prefilled syringe;

Figure 6 is a view of the assembly corresponding to Figure 3, after activation;

5 Figure 7 is a view of the assembly after the plunger has been pressed upwardly to transfer liquid from the bottomless vial to the pharmaceutical vial;

Figure 8 is a view showing a mixing step;

10 Figure 9 shows upper portions of the assembly being removed, leaving a syringe ready for application of a needle or other discharge means;

Figure 10 shows a partially exploded view of a modified embodiment of delivery system utilizing a different form of protosyringe;

15 Figures 11 and 12 are fragmentary sectional views of an alternative form of syringe socket and associated parts which permit elements of the delivery system to be used in further embodiments of delivery system in conjunction with prefilled protosyringes or pharmaceutical vials;

20 Figure 13 shows in section a cap which may be applied to a luer on a hub portion of the embodiment of Figures 11 and 12 to enable the hub to be driven from the position to Figure 11 to that of Figure 12 to activate a prefilled protosyringe;

25 Figure 14 shows in an exploded view parts of an alternative activation system for use with the embodiment of Figures 11 and 12 so as to activate a syringe or vial for use in conjunction with a standard flexible mini-bag;

Figure 15 shows an assembled syringe ready for activation;

30 Figure 16 shows an activated syringe applied to a mini-bag;

Figure 17 is an exploded view illustrating components of a presently preferred modification of the embodiment of Figures 1-9;

35 Figure 18 shows the parts shown in Figure 17 assembled

ready for use, less the plunger;

Figures 19 and 20 illustrate a presently preferred modification of the embodiment of Figures 11 and 12;

Figure 21 illustrates the assembled components of a
5 further embodiment of assembly according to the invention;

Figure 22 is an exploded view of components of a hub assembly used in the embodiment of Figure 21;

Figure 23 illustrates a modification of the embodiment of Figure 18, showing how the assembly of the invention may
10 be used to activate pharmaceuticals having more than two components;

Figure 24 illustrates an assembly in accordance with a further embodiment of the invention; and

Figure 25 is a flow diagram illustrating the
15 preparation of assemblies in accordance with the embodiment of Figures 17 and 18.

DESCRIPTION OF THE PREFERRED EMBODIMENTS

Referring first to Figures 1 to 3, the parts are shown
20 of an assembly for preparing a syringe containing a pharmaceutical preparation, components A and B of which are contained respectively in a pharmaceutical vial 2 and a protosyringe in the form of a bottomless vial 4 consisting of a cylindrical body 6, open at one end and provided with
25 a neck 8 at its other end, the neck being closed by an elastomeric closure 10 secured in place by a metal cap 12 crimped over the neck. A piston 14 is lodged in the open end of the body, the piston being provided with means 16 by which a detachable plunger 18 may be secured to the piston.
30 The plunger will normally be shipped detached from the piston, both to reduce the overall length of the assembly, and to permit a removable cap 20 to be applied over a projecting end of the bottomless vial 4 as shown in Figure 2 so as to prevent inadvertent premature activation of the
35 assembly.

At least one of the components A and B is liquid; usually it will be convenient to locate a liquid component in the bottomless vial but it would be possible to locate a solid component in the bottomless vial provided that the latter also contains an air or gas volume sufficient to
5 displace liquid contents of the vial 2.

Since a typical two component pharmaceutical for administration via a syringe comprises an active ingredient and a liquid solvent, diluent or carrier (hereinafter
10 collectively referred to as diluent for convenience) which in the majority of cases will be one of only a few different types (most usually distilled water), it will usually be advantageous to place the active component in the vial 2;
15 this is because in many, if not most cases, a suitable vial package of the active ingredient will already be certified by regulatory authorities, or need in any event to be so certified, while certification of the protosyringe containing the diluent will generally be straightforward if
20 the diluent is conventional and the protosyringe structure itself is already certified. The transfer assembly will be generic and can be separately certified; accordingly combinations of pharmaceutical components and assemblies for converting them into filled syringes can be assembled from
25 separately certified components with little if any need for certification of the combination.

A main portion of the assembly has a tubular body formed by two components, a vial coupling 22 and a syringe
30 socket 24. The syringe socket 24 has an externally threaded end portion 26 at one end which screws into an internal thread 28 at an adjacent end of the vial coupling 22. The vial coupling provides a cylindrical recess 30 to receive a capped end of the vial 2, whose degree of insertion is
35 limited by a shoulder 32. The syringe socket 24 provides a

cylindrical recess 31 into which may be slid the body 6 of the bottomless vial 4, although not initially to the full extent permitted by the depth of the recess.

5 The end portion 26 of the syringe socket includes a guide 52 for longitudinal movement of a hub 34, formed at a front end with a liquid delivery conduit through a standard luer as utilized in the industry for coupling needles, or other delivery instrumentalities forming liquid delivery
10 conduit extensions, to syringes and other sources of liquid pharmaceuticals. Such a luer comprises an internally threaded socket 36 for locking a needle in place, and a tapered central spigot 38 for establishing a seal with a complementary socket on the needle. In the present
15 instance, a hollow transfer needle 40 has a socket 41 lodged on the central spigot, but is not provided with threads to engage those of the socket 36, so the needle 40 may be pulled from the spigot 38. A tapered shoulder 42 is formed on the transfer needle 40. The hub 34 has a hollow needle
20 or cannula 44 projecting from its end opposite the spigot 38 and in communication with a central passage in the spigot. A flexible needle sheath or shield 46 of thin rubber covers the needle 44, having a portion 48 engaging a socket in the end of the hub 34, and a flattened end 50 over the free end
25 of the needle. Internally of the guide 52, the end portion 26 of the syringe socket also contains an extension of the cylindrical recess 31 dimensioned to provide an overcap which is a press fit over the cap 12 of the bottomless vial
30 4.

30 The vial coupling 22 has a passage extending from the recess 30 which receives the vial 2 to its internally threaded end, the passage being closed by a rubber stopper or shield 54. Between the rubber stopper and the internally
35 threaded end of the coupling 22, the passage is formed

internally with resilient pawls 56 which will detain the shoulder 42 of the needle 40 when the latter is pressed past the pawls.

5 The assembly just described may be shipped on its own with neither vial installed, in which case a removable cover (not shown) will be required to cover the cylindrical recess in the coupling 22 to maintain sterility, or with one or both vials installed (see Figures 2 and 3). When a vial 2
10 is installed, any removable central portion of a cap 60 covering a penetrable closure 58 of the vial is flipped off, so that the penetrable closure may contact a rib 64 on the stopper 54 to enclose an axial sterile zone of the two rubber parts 58 and 54. Likewise, an axial zone of the
15 closure 10, similarly exposed, contacts the end 50 of the needle sheath 46 to provide protected zones on the contacting rubber parts.

 In order to activate the assembly, after installation
20 of the vials to provide the arrangement shown in Figure 3, the bottomless vial is pressed into the syringe socket 24, and the plunger 18 is attached to reach the condition shown in Figure 6.

25 Thereafter, the assembly is inverted and plunger 18 is activated to project the liquid content B from the bottomless vial into the pharmaceutical vial, (see Figure 7), the assembly then being swilled as shown in Figure 8 to dissolve, mix or suspend the contents of the vial 2 in the
30 liquid, which is then aspirated back into the bottomless vial by withdrawing the plunger to reach a condition similar to that of Figure 6, except that component A is now incorporated into component B to leave a product C in the bottomless vial. The vial 22 is now unscrewed from the
35 syringe socket 24 and withdrawn, taking with it the transfer

needle 40 which is pulled off the spigot 38 by the pawls 56, thus leaving the luer of hub 34 ready to receive a needle or other fluid connection instrumentality, and providing a completed ready to use syringe, filled with the two component pharmaceutical (see Figure 9). The hub 34 is retained on the cap 12 of the bottomless vial by the syringe socket 24, with the needle providing a passage between the body 6 and the luer 36, 38.

10 If the initial position of liquid and solid components is reversed, the step of Figure 7 may be performed without inversion, with reciprocation of the syringe plunger being used to force air or gas from the vial 4 to the vial 2, and liquid from the vial 2 to the vial 4.

15

A presently preferred modification of the assembly described above is shown in Figures 17 and 18, in which the same reference numerals are used to designate similar parts, and only the differences are described. In this modification, the flange 35 of the hub 34 is extended to form the overcap, and the portion 26 of the syringe socket 24 acts to receive the forward portion of this overcap when the syringe body 6 is forced forward against and into the overcap during activation of the syringe. As best understood from Figure 25, this rearrangement facilitates assembly. The cap 20 is replaced by a driver 21, which snaps into the opening of the syringe socket 24 as shown in Figure 18 in a position in which it covers the rear of the protosyringe, and from which position it can be driven forward to activate the assembly. The driver 21 has a bottom aperture to accommodate the plunger 18. The stopper 54 is replaced by a flexible sheath 54 similar to the shield 46, since this is found to simplify assembly and provides complete coverage of the needle 40.

35

Various modifications are possible within the scope of the invention, the above description being of a presently preferred example. For instance, the needle 40 could be permanently secured to the hub 34, and the pawls in the vial omitted. Such an arrangement does not provide the user with any choice as to the needle to be used on the finished syringe, and needle length may be severely limited by the need to avoid excess needle extent to the vial 2, which would make it difficult to aspirate its contents.

10

Likewise, the bottomless vial 4 may be replaced by other forms of protosyringe such as cartridges, or by a prefilled syringe provided with an elastomeric closure covering a luer connection, the front end of the syringe accepting an overcap providing such a needle connection and acting to retain the hub. Such an arrangement is exemplified in Figure 10, which shows the bottomless vial replaced by a protosyringe which is a conventional prefilled syringe having a conventional luer nozzle 101 protected by a protective rubber sealing cap 100 over a front end of the syringe body, and the syringe socket 24 is modified in shape to receive the body 6 of the syringe, with longitudinal internal ribs 102 to grip the syringe body. As before, a cap 20 prevents the syringe body from being driven fully into the syringe socket 24 until activation is required, and the end 50 of the shield 46 rests against the cap 100 to help maintain sterility of the zones to be penetrated by the needle 44.

30

Yet further forms of protosyringe may be employed. For example, a known form of diluent vial comprises a body 6 in the form of a glass tube with a piston at both ends. The piston at one end is similar to the piston 14 with an extension similar to the extension 16. The piston at the other end fulfills the function of the neck 8, stopper

35

10 and cap 12 of the bottomless vial shown in Figure 1. In conventional use, this other end of the vial is inserted into an open end of a sleeve which at its other end supports a luer or needle externally and an axial hollow pin projecting internally. The piston at the other end of the vial has an axial passage, through the piston and an outward extension of the piston, closed at its outer end by a bung which is displaced by the hollow pin on insertion of the vial into the sleeve, thus establishing communication between the needle or luer and the interior of the vial. Protosyringe from a vial into a syringe is completed by applying a plunger of the piston at the first end. This type of protosyringe can be substituted in the present invention for that shown in Figure 1 or Figure 17. During activation, the overcap 16 or 35 will be driven into the extension of the piston at said other end of the vial so that the needle 44 penetrates the sheath 46 and displaces the bung. The bung may be replaced by an integral septum in the passage of the piston which is penetrated by the needle 44.

The syringe socket itself may be made detachable from the completed syringe except for the overcap, or may be truncated in length as shown in Figures 11 and 12. It will be seen that the syringe socket 24 is shortened and reduced in diameter to receive the cap 12 of a bottomless vial, the syringe socket being pushed down over the cap 12 to engage the shoulder of the syringe body 6.

On activation of the syringe the hub 34 is driven downwardly relative to the end portion 26 of the socket 24 from the position shown in Figure 11 to the position shown in Figure 12. In the position shown in Figure 11, the end 50 of the rubber shield 46 rests against the closure 10 so as to provide a protected contact zone, which is penetrated

by the needle 44 on the hub 34 as the hub is driven downwardly through the guide 52 until a flange 35 on the bottom of the hub 34 contacts the closure 10. At this point the needle 44 establishes communication with the interior of the body 6 of the protosyringe.

Figure 21 shows how the arrangement of Figures 11 and 12 (or Figures 19 and 20 considered below) may be used in an arrangement in which the assembly is activated by insertion of the vial 2. As best seen in Figure 22, the component 42 is lengthened and modified so that it, the penetrable shield 54 on the cannula 40, and the cannula 40 itself, project into the vial socket 32. On insertion of the vial 2, the shield 54 is pressed into a recess in the arrangement 42 so that it is penetrated by the cannula, which also penetrates the closure of the vial 2, and the vial closure presses on the component 42 so as to drive the cannula 44 through its sheath or shield and the penetrable closure of the protosyringe. If the modification of Figures 19 and 20 is used, with a hub 34 modified as shown in Figure 22 so that the flange 35 provides the overcap, this driving action also drives the overcap 35 onto the cap of the protosyringe. If the arrangement of Figures 11 and 12 is used, the cap of the protosyringe is already lodged in the overcap.

Figure 13 illustrates an alternative means of driving the hub 34. The luer spigot 38 of the hub 34 is covered by a conventional moulded cover 104, shown in section in Figure 13, screwed into the socket 36 and providing a convenient driver for the hub which can be unscrewed and discarded preparatory to fitting a needle to the luer of the hub.

Figures 14 and 15 illustrate an alternative driver arrangement, making use of a known type of adapter used to couple syringes to flexible mini-bags so that the contents

of the syringe may be discharged into the bag and mixed with the contents of the latter. The adapter 106 consists of a tube 108 which has an internally threaded socket 118 at one end for screwing in the present case on to complementary external threads on the portion 26 of a syringe socket 24, and slots 110 at the other end to engage lugs on a nipple of the bag so that the nipple is guided into the adapter concentrically aligned with a needle 112 fitted to the spigot 38 of the hub 34. A cap 114 covers the slotted end of the tube 108, and has a concentric internal tubular extension 116 that sheathes the needle 112, and extends the socket 36 of the hub 34 when the latter is in the position shown in Figure 11, with the tube 108 extending only part way into the cap 114. Pushing further on the cap will force the hub 34 from the position shown in Figure 11 to the position shown in Figure 12, thus activating the syringe. The cap 114 may then be removed, and the syringe applied to a mini-bag as shown in Figure 16. Alternatively the tube 10 may also be removed providing a ready to use syringe.

Instead of a protosyringe in the form of a bottomless vial, the arrangement of Figures 11, 12, 14 and 15 may also be used to activate a regular pharmaceutical vial so that its contents may be mixed with those of a mini-bag or other flexible bag. Liquid from the flexible bag may be caused to enter the activated vial through the needle, and the admixed contents of the vial then allowed to run back into the bag through the needle by suitable manipulation of the bag and the attached activated vial.

The arrangement shown in Figures 11 and 12 may also be modified as shown in Figures 19 and 20 by extending the flange 35 of the hub 34 to form the overcap (see also Figure 22). In order to accommodate downward movement of the overcap while preventing inward movement of the

protosyringe, the reduced diameter portion of the syringe socket is extended downward as at 27 to form a shoulder limiting insertion of the protosyringe.

5 Figure 23 shows a modification of the embodiment of
Figures 17 and 18 to allow preparation of a three component
pharmaceutical. The vial socket 22 is bifurcated, as is the
component 42, so as to provide two vial sockets 30, and two
10 needles which are not seen since they are covered by sheaths
54. On activation of the assembly by driving the driver 21
into the syringe socket 24, the closures of the vials will
be penetrated simultaneously, enabling liquid from the
protosyringe body 6 to enter both vials 2 and dissolve or
15 suspend their contents. On activation, latch members 56
engage the component 42 to retain it, as in previous
embodiments.

 A further vial socket 30 and a further branch of the
component 42 may be provided for each additional component
20 to be handled.

 Referring now to Figure 24, the principles of the
invention may also be utilized with protosyringes in the
form of a shell vial (or as shown, the functional equivalent
25 of a shell vial produced by reversing a bottomless vial 206
as described in U.S. 5,364,369A and applying a driver cap
220 to its cap end). Such shell vials are normally formed
into a completed syringe by screwing a threaded extension
216 of a piston 214 into a free end of a plunger stem within
30 a concentric syringe shell connected to the other end of the
plunger. A double ended needle extends axially of the
plunger stem and out of its other end. Screwing the
extension 216 fully onto the plunger stem causes the needle
to penetrate the piston so that the contents of the shell
35 vial may be expelled through the needle by driving the vial

5 onto the plunger stem. Such an arrangement is described in US 5,171,214A already referenced above. In the present instance, a syringe socket 224 provides the shell, and the hub assembly utilized in the embodiment of Figures 1-10, modified as shown in Figures 17 and 18, is further modified by providing an elongated cannula 244 surrounded by a concentric plunger stem 218 positioned on the cannula by passing through a flange 245 and entering the overcap 35. The length of the cannula 244 is such that it ends short of a penetrable septum (not shown) within the piston 21 with the components in the unactivated state shown in Figure 24, with the piston extension 216 screwed into a threaded socket at the bottom of stem 218.

15 The assembly is activated by driving the shell vial upwardly so that a reduced diameter portion 219 of the stem 228 enters the overcap 35, permitting the cannula 244 to perforate the septum in the piston. Further upward movement causes the cannula supported at the upper end of the hub to penetrate the sheath 64 and the penetrable closure of the vial 2, whereafter activation can proceed as previously described save that the shell vial 206 is manipulated in place of a conventional plunger.

25 Referring now to Figure 25, there is shown a flow diagram of the preparation of an assembly in accordance with the invention, specifically the embodiment of Figures 17 and 18.

30 Starting at the top left, the parts 34, 35, 42, 46 and 64 are assembled to form the hub assembly 300, which is then sterilized by gamma radiation (step 32°). Within a clean room 314 (top right) the parts 6, 12, 14, 16 are assembled and filled to provide a protosyringe 304 to the cap of which the overcap 35 is applied, but not far enough for the

35

cannula within the overcap 35 to penetrate the shield or sheath 46, to provide subassembly 306, which then passes through an inspection station 316.

5 In the meanwhile parts 21, 22 and 24 are assembled to provide a subassembly 302 and, together with the plunger 18, sterilized by gamma radiation at 322. The assembly 306 of protosyringe and hub assembly is inserted into the assembly 302 under a laminar flow hood to provide the assembly 308,
10 whereafter, in the same environment, a vial 2, from which any protective metal disc on the cap has been flipped off, is inserted into the vial socket of the assembly 308, which corresponds exactly to that of Figure 18. The contacting surface of the penetrable closure 58 (see Figure 1) of the
15 vial 2 and the surface 50 of the shield 64 are sterilized by a high intensity ultraviolet flash or an antiseptic spray 318 during this step, whereafter the resulting assembly 310 together with the plunger 18 is sealed into a plastic tray 312. The tray is vacuum formed with a recess shaped to
20 correspond to the profile of the assembly 310. In particular, it is advantageous that this recess snugly embraces the narrower portion of the actuator 21 to avoid any possibility of inadvertent activation prior to use occasioned by shock or rough handling.

25 Variations are of course possible in this procedure. For example, the protosyringe 304 like the vial might be preproduced and terminally sterilized, and assembled to the hub assembly to produce the assembly 306 in a similar manner to combination of assemblies 302 and 308.

30

CLAIMS:

1. An activation assembly for a protosyringe or pharmaceutical vial having a penetrable septum, comprising a tubular socket having a first portion extending from an open end to receive in said open end at least a portion of a protosyringe or pharmaceutical vial presenting the penetrable septum, a second portion extending from the first portion to an opposite end of the socket, a guide at said opposite end of the socket, and a hub assembly movable within said guide for movement axially of said second portion of the socket, the hub assembly having a cannula extending into the socket at one end thereof from a liquid delivery conduit at the other end thereof, and a penetrable sheath enclosing the cannula, the hub and the protosyringe or pharmaceutical vial being relatively movable within the socket between a position in which the shield contacts the penetrable septum in a zone coaxial with the cannula, and a position in which the cannula penetrates both the shield and the septum.
2. An activation assembly according to Claim 1, wherein the first portion of the socket is of a diameter to receive a body portion of a protosyringe, and the second portion is of a diameter to receive or provide an overcap for the protosyringe upon that portion of the latter presenting the penetrable septum being forced into the overcap, and wherein the hub assembly is position to be projected outwardly through the guide by entry of said portion of a protosyringe into the overcap.
3. An activation assembly according to Claim 1, wherein the first portion of the socket is of a diameter to receive a portion of a vial or protosyringe vial presenting said penetrable septum, and the second portion is of a diameter to receive or provide an overcap for said portion of the

vial or protosyringe, and wherein the hub assembly is positioned to be projected inwardly through the guide and the second portion of the socket to drive the cannula through the shield and the penetrable septum.

5

4. An activation assembly according to Claim 1, 2 or 3, wherein the liquid delivery conduit comprises a luer.

10

5. An activation assembly according to Claim 4, wherein the activation assembly comprises a second socket, oppositely directed to the first and having a first portion extending from an open end to receive in said open end a portion of a container having a penetrable septum, and a second portion extending to said guide, the liquid delivery conduit of said hub assembly extending into said second portion of the second socket and including a second cannula detachably mounted on said luer, and a second penetrable shield enclosing the second cannula, the hub assembly and the container being relatively movable within the socket between positions in which the second shield contacts the penetrable septum of the container in a zone coaxial with the cannula, and positions in which the second cannula penetrates the second shield and the second septum.

15

20

25

6. An activation assembly according to Claim 5, wherein the container is a pharmaceutical vial.

30

7. An activation assembly according to Claim 3, including a driver component to project the hub assembly inwardly through said guide and said second socket portion.

35

8. An activation assembly according to Claim 7, wherein the liquid delivery conduit is a luer and the driver component is a detachable cap applied to the luer.

9. An activation assembly according to Claim 7, wherein a needle is mounted on the luer, an adapter tube surrounding the needle is attached at one end to the socket and at the other end is shaped to guide a nipple of a flexible bag onto the needle, and a cap is provided which is slidable relative to the other end of the socket and has a tubular extension extending within the adapter or engage the hub assembly and drive the cannula through the closure of a vial whose cap is received in the socket.

10

10. An activation assembly according to Claim 8, wherein the vial is a bottomless vial.

15

11. An activation assembly for preparing a prefilled syringe from separately prepackaged components of a multicomponent pharmaceutical preparation, the assembly comprising a two part tubular body; the body defining in a first part a first cylindrical recess at one end of a diameter to receive, as a sliding fit, a capped end of a protosyringe at which end a cap retains a penetrable closure on a neck of the protosyringe, as well as a substantial portion of a cylindrical body of the protosyringe, the cylindrical body containing a first, liquid component of the pharmaceutical preparation, retained in the body by a piston within the cylindrical body and forming a hermetic sliding seal therewith; a second cylindrical recess defined in the other end of the tubular body by a second detachable part to receive as a press fit a cap securing a penetrable closure at the neck of a pharmaceutical vial containing a second component of the pharmaceutical preparation; the tubular body defining in said first part a passage connecting the cylindrical recesses; a hum movable longitudinally of the tubular body within the passage; cannulas extending longitudinally of the tubular body from said hub to distal ends in opposite directions and communicating with one

35

another through said hub; penetrable shield members covering the distal ends of the cannula and located to contact penetrable drivers of a protosyringe and of a pharmaceutical vial inserted in the cylindrical recesses; and a hollow cylindrical overcap concentric with the hub assembly and located within the tubular body in the first cylindrical recess, the overcap being connected to the hub to limit movement of the latter into the passage; the depth of the cylindrical recess, the length of the passage connecting the recesses, the extent of the cannulas from the hub, and the location of the overcap in the first cylindrical recess, being such that upon a protosyringe received in the first cylindrical recess and a vial received in the second recess being driven towards each other, the overcap is driven onto the cap of the protosyringe and the hub moves longitudinally so that the cannulas penetrate both penetrable sealing members and the penetrable closures of the protosyringe and vial respectively to place the protosyringe and vial in fluid communication through the cannulas.

20

12. An assembly according to Claim 11, wherein the overcap is integral with said first part of the tubular body.

25

13. An assembly according to Claim 12, wherein said overcap is integral with the hub.

30

14. An assembly according to Claim 13, wherein a shoulder is defined in the first recess limiting movement of the cylindrical body of a protosyringe into the first recess such that as to limit its engagement with the overcap to a point where it contacts the sealing member associated with the cannula directed towards the first recess without causing penetration of that sealing member or the penetrable closure of the protosyringe, and a cap of a vial can be pressed far enough into the second recess for the cannula

35

directed towards that recess to penetrate its associated sealing member and the penetrable closure of the vial, and for the penetrated vial to drive the hub downwards to force the overcap onto the cap of a protosyringe fully inserted in the first recess, and to start the cannula directed towards the first recess through both the sealing member associated therewith and the penetrable closure of the protosyringe.

15. An assembly according to Claim 3, wherein a shoulder is defined in the second recess limiting movement of a cap of a vial into the recess to a location contacting the sealing member associated with that cannula directed towards the second recess without causing penetration of that sealing member or a penetrable closure of the vial, and a cap of a protosyringe can be pressed far enough into the first recess for the cap to enter the overcap far enough that the cannula directed towards the first recess penetrates both the sealing member associated with that cannula and a penetrable closure of the protosyringe and drives the hub sufficiently towards the second recess that the cannula directed towards that recess penetrates both the sealing member associated therewith and a penetrable closure of a vial fully inserted in the second recess.

16. An assembly according to Claim 14, wherein the part of the tubular body defining the second recess includes a detent limiting insertion of a cap of a vial, to a point at which a penetrable closure of the vial contacts the sealing member associated with the cannula directed towards the second recess without resulting in penetration of the sealing member or penetrable closure, until sufficient pressure is applied to the vial to overcome the detent.

17. An assembly according to Claim 15, wherein the overcap includes a detent limiting insertion of a cap of a

protosyringe, to a point at which a penetrable closure of the protosyringe contacts the sealing member associated with the cannula directed towards the first recess without resulting in penetration of the sealing member or penetrable closure, until sufficient pressure is applied to the protosyringe to overcome the detent.

18. An assembly according to Claim 12, wherein the overcap includes a detent limiting insertion of a cap of protosyringe, to a point at which a penetrable closure of the protosyringe contacts the sealing member associated with the cannula directed towards the first recess without resulting in penetration of the sealing member or penetrable closure, until sufficient pressure is applied to the protosyringe to overcome the detent.

19. An assembly according to Claim 11, wherein one end of the cannula, facing a pharmaceutical vial whose cap is installed in the second recess, is separately formed and detachable from the hub assembly and the hub assembly has a luer on which said one end of the cannula is releasably lodged, and means are provided within the detachable part of the tubular assembly to detain within the tubular assembly said one end of the cannula when the cannula is driven into a position penetrating the cap of the pharmaceutical vial.

20. An assembly according to Claim 11, wherein the sealing members are disposed within the assembly so that areas of these members will enter resilient contact with areas of the penetrable closures of a protosyringe and a vial which are concentric with the cannula when the protosyringe and the vial are installed in their respective cylindrical recesses.

21. An assembly according to Claim 11, wherein the body defines, in said second part, plural second cylindrical recesses to receive caps of plural pharmaceutical vials, and said hub comprises plural cannulas extending towards said
5 second cylindrical recesses, and plural sealing members associated with said plural cannulas.

22. An assembly according to Claim 3, wherein the activation assembly comprises a second socket, oppositely
10 directed to the first and having a first portion extending from an open end to receive in said open end an open end of a shell vial closed by a piston having a penetrable septum, and a second portion extending to said guide, the liquid delivery conduit of said hub assembly comprising a cannula.

15

23. An assembly according to any of Claims 6 or 11 - 22, including a protosyringe and a pharmaceutical vial.

24. A method for producing an assembly according to Claim
20 6, including two components of a pharmaceutical, at least one of which is liquid, which can be activated to provide a prefilled syringe, comprising producing a sterile protosyringe containing a liquid component of the pharmaceutical, and a sterile pharmaceutical vial containing
25 a second component of the assembly, producing a subassembly comprising said first and second sockets and said guide, producing a hub assembly, sterilizing said subassembly and said hub assembly, and inserting said assembly and said protosyringe into said first socket and said vial into said
30 second socket while maintaining sterility at the zones of contact of the shields with the penetrable septums.

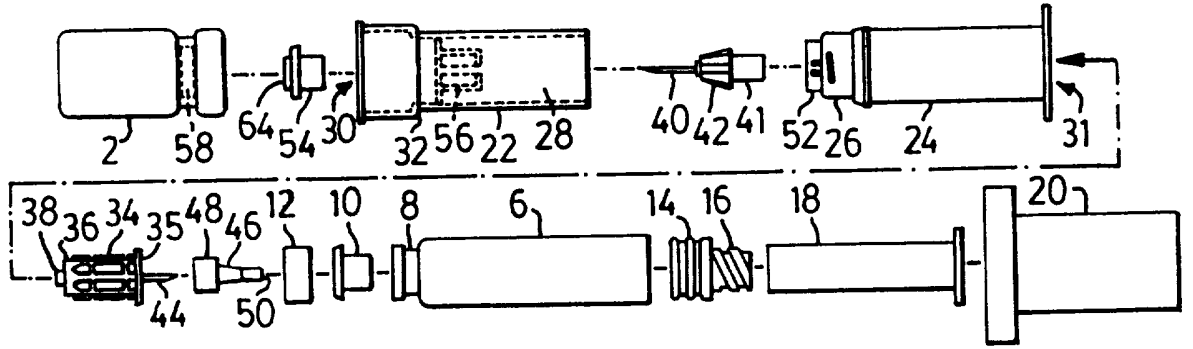

FIG. 1

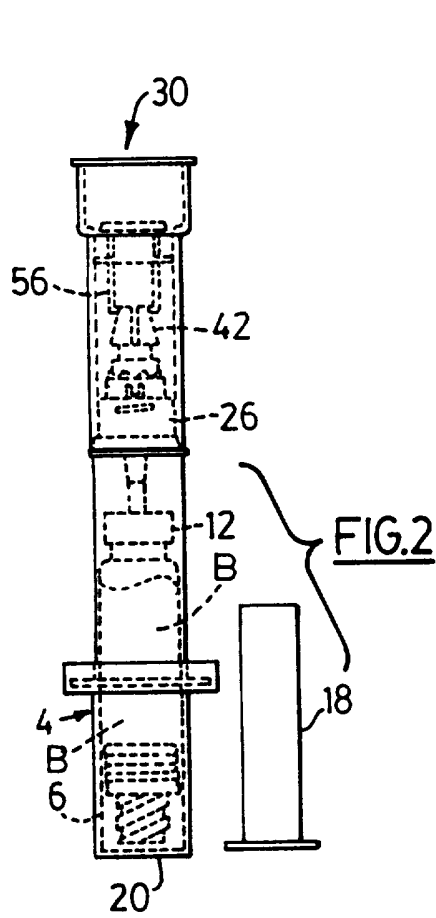

FIG. 2

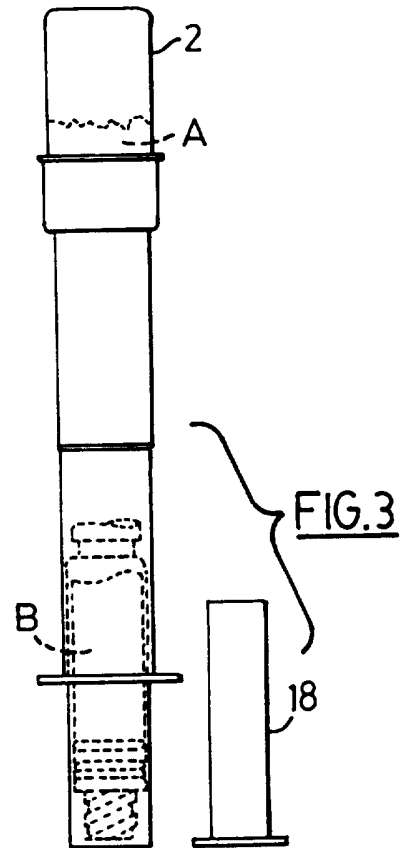
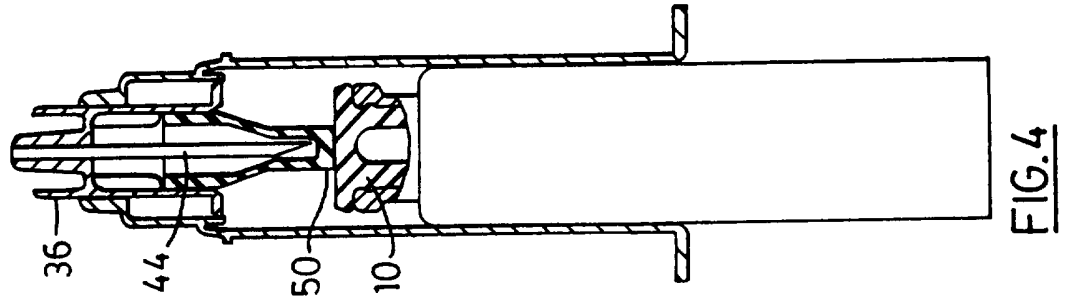
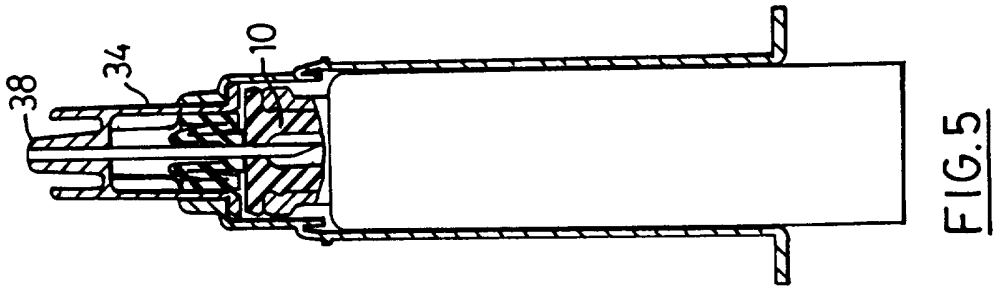
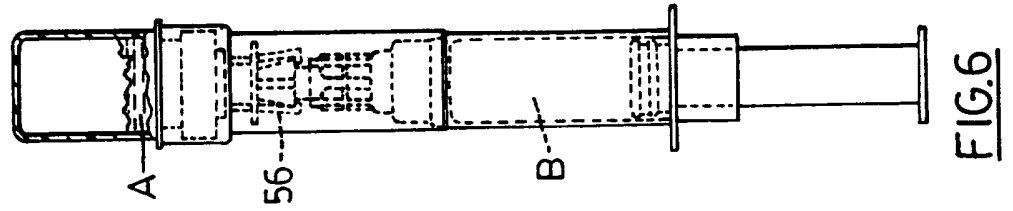
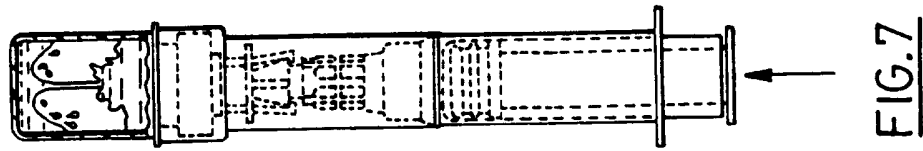
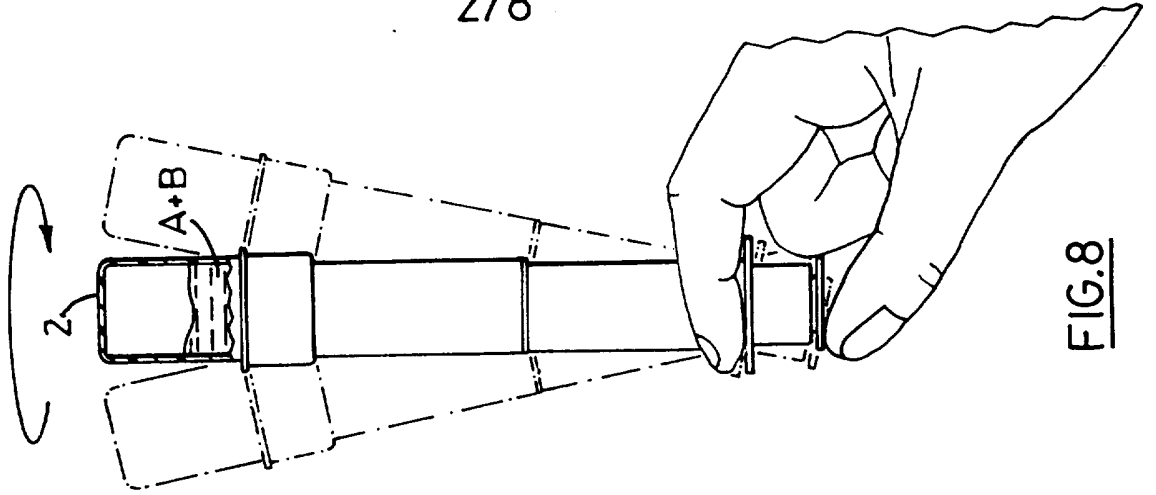
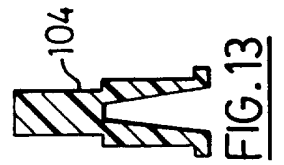
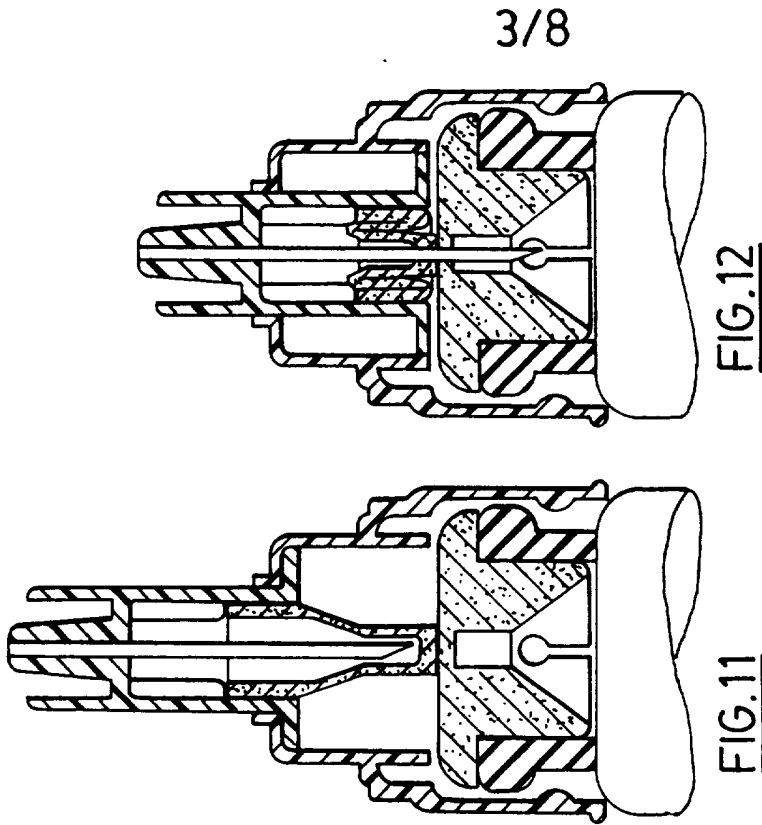
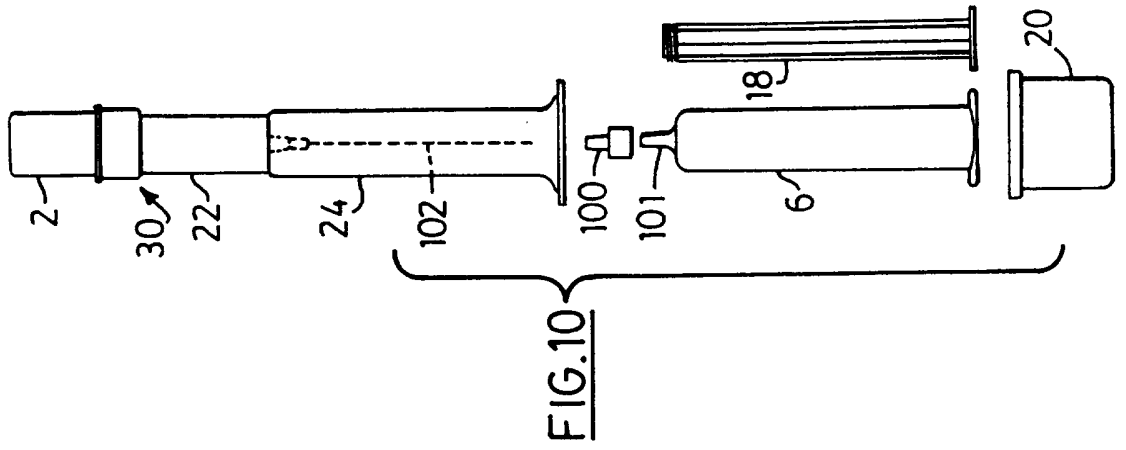
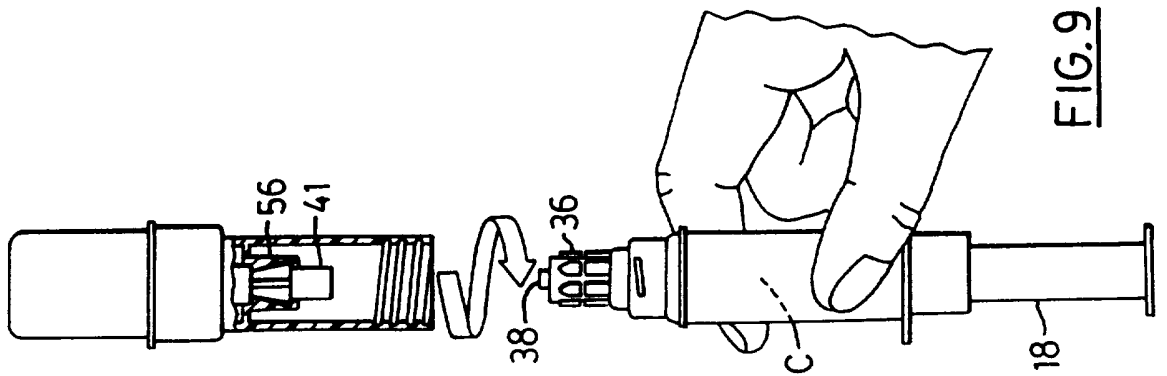

FIG. 3





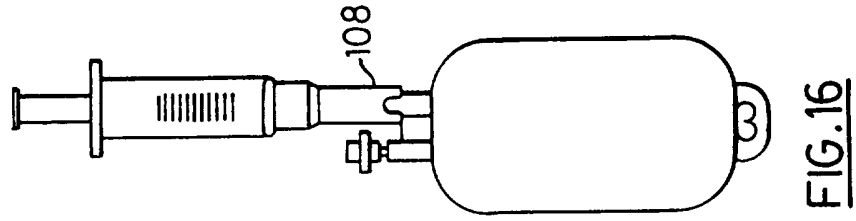

FIG. 16

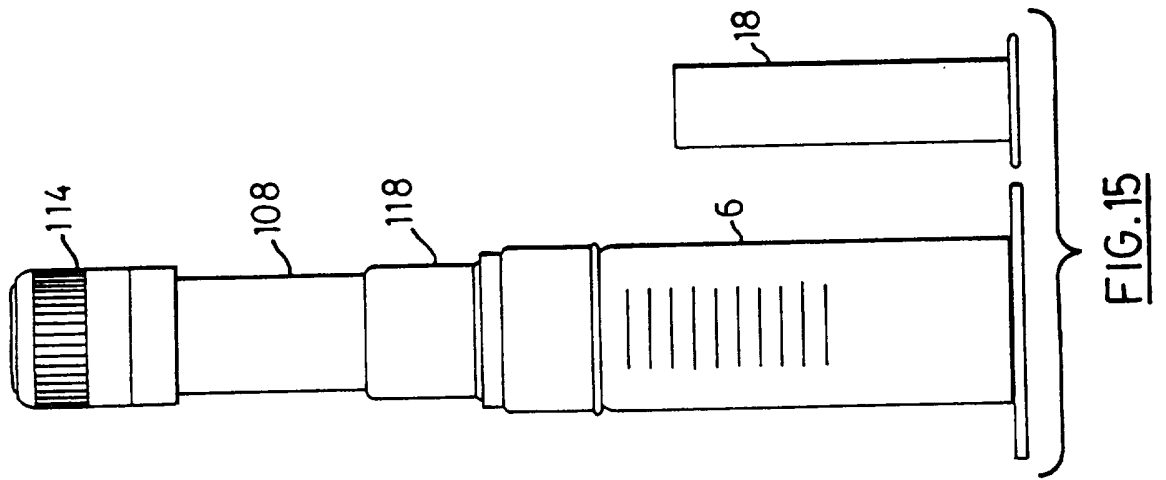

FIG. 15

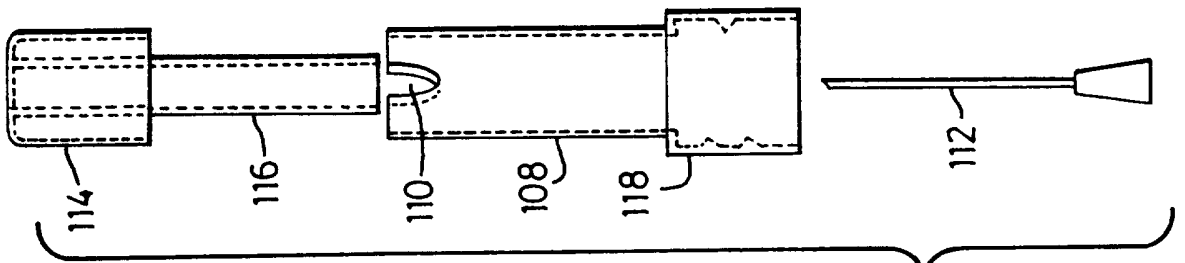

FIG. 14

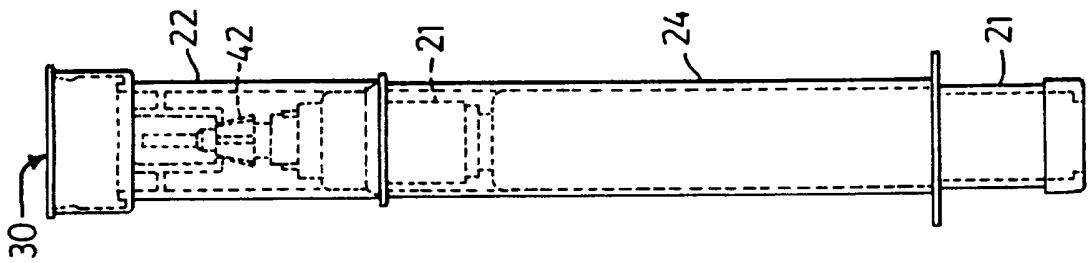

FIG. 18

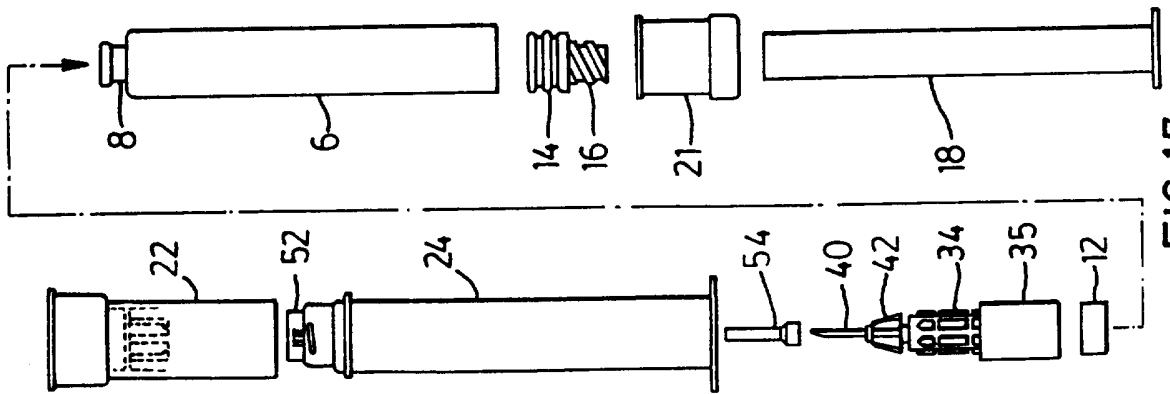

FIG. 17

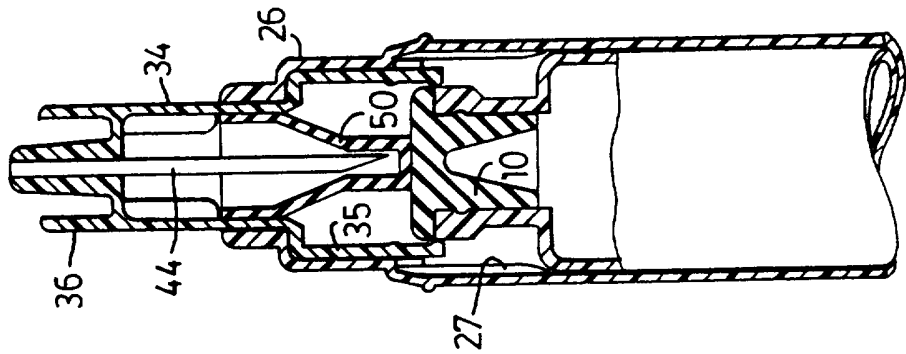

FIG. 19

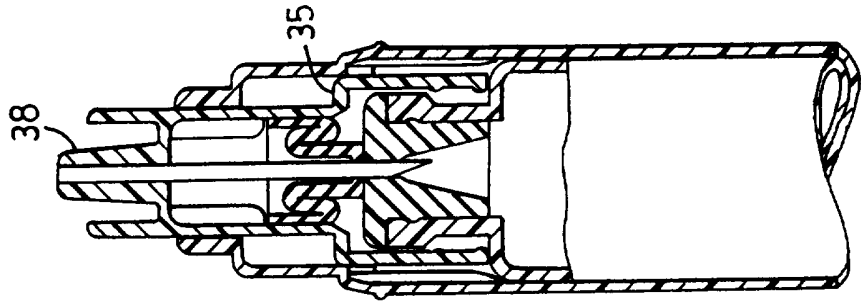
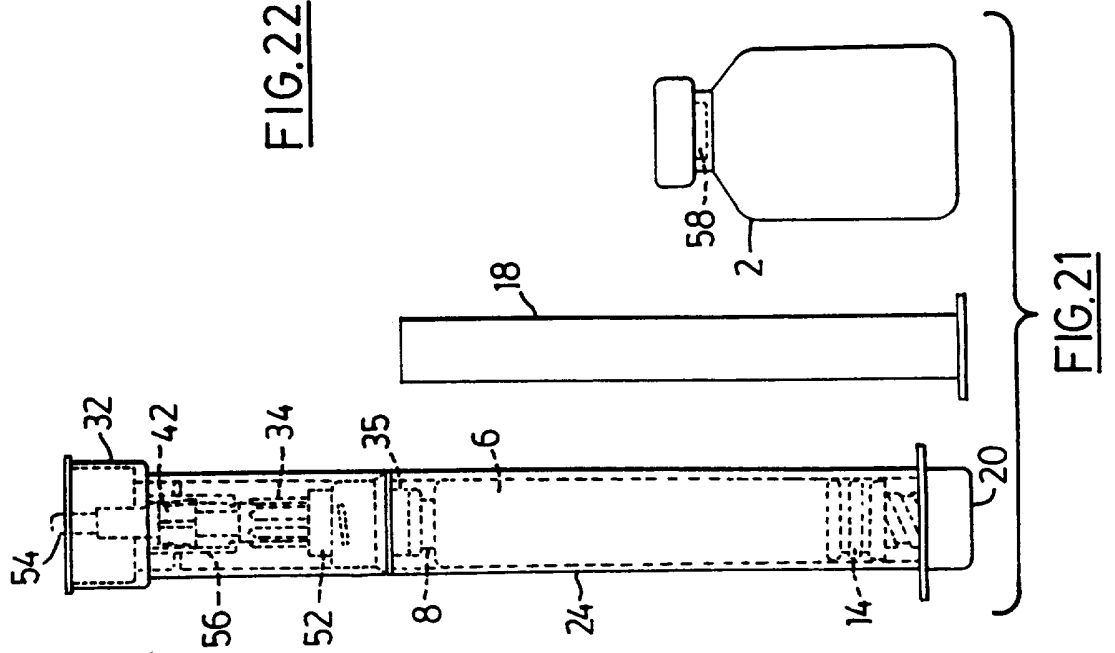
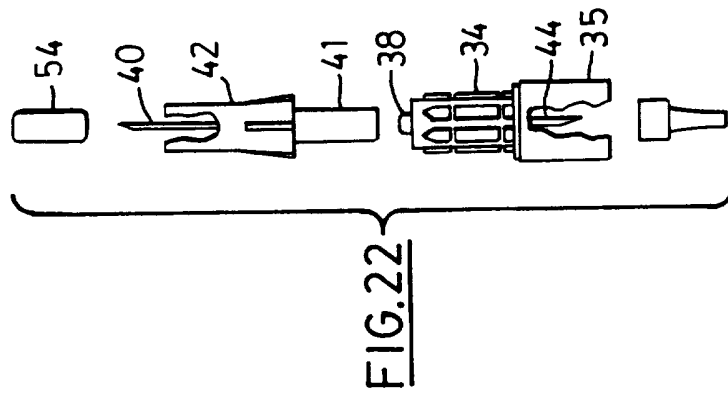
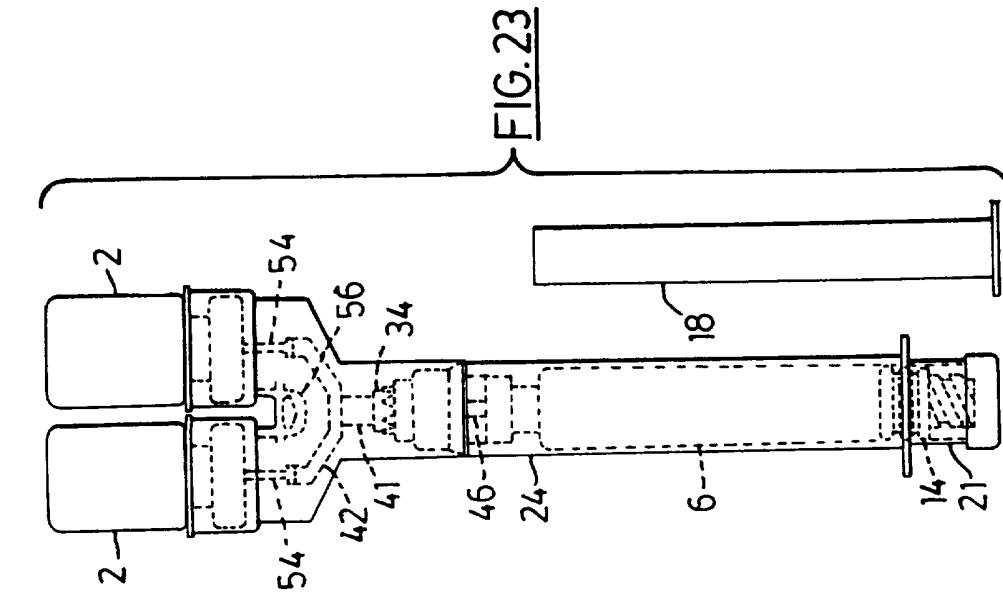

FIG. 20



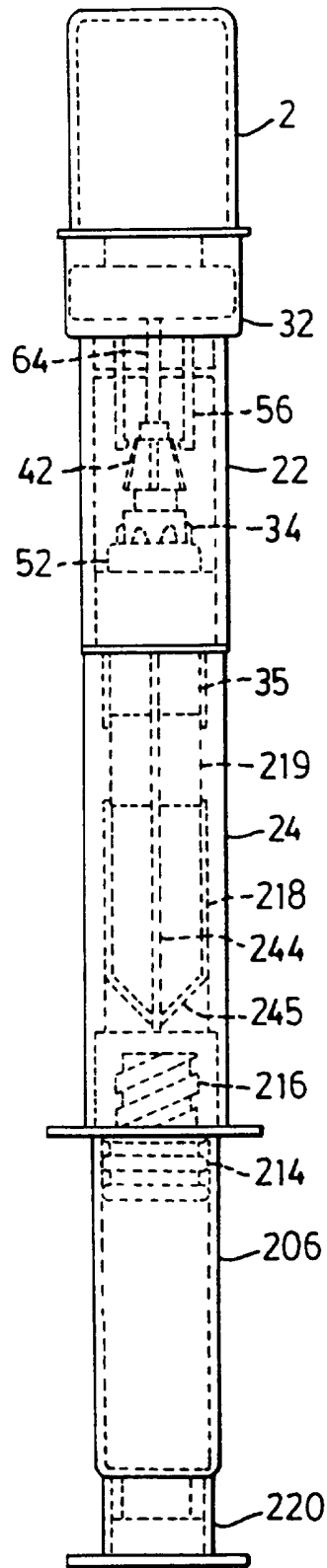

FIG.24

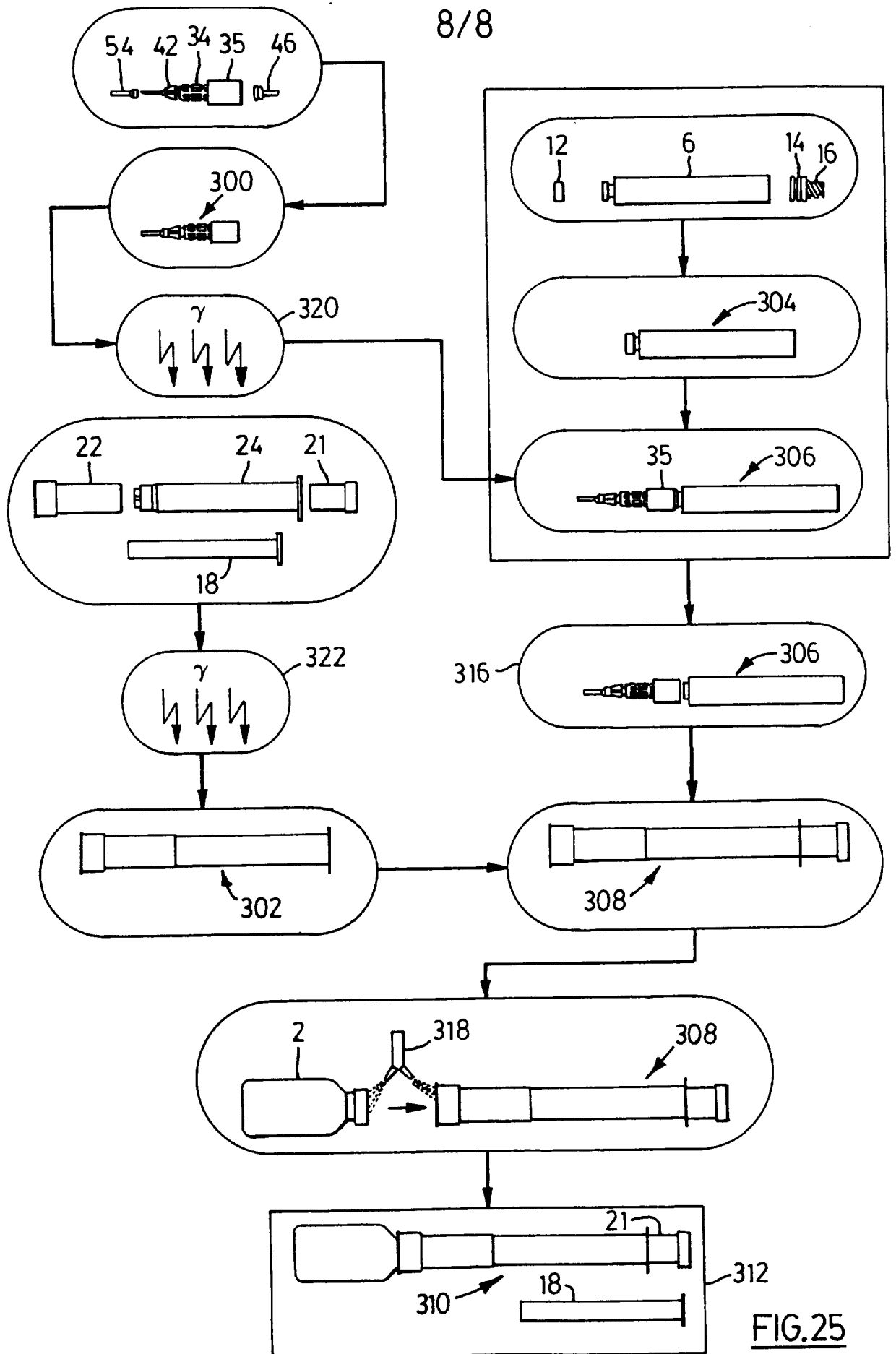

FIG.25

INTERNATIONAL SEARCH REPORT

In' tional Application No
PCT/CA 97/00017

A. CLASSIFICATION OF SUBJECT MATTER
IPC 6 A61J1/00

According to International Patent Classification (IPC) or to both national classification and IPC

B. FIELDS SEARCHED

Minimum documentation searched (classification system followed by classification symbols)

IPC 6 A61J

Documentation searched other than minimum documentation to the extent that such documents are included in the fields searched

Electronic data base consulted during the international search (name of data base and, where practical, search terms used)

C. DOCUMENTS CONSIDERED TO BE RELEVANT

Category *	Citation of document, with indication, where appropriate, of the relevant passages	Relevant to claim No
X	DE 19 13 926 A (FARBWERKE HOECHST AG) 24 September 1970 see page 3, line 8 - page 5, line 8 see figures 2-4	1,3,7
Y		2,4-6, 11-13,24
A		10,20, 22,23
Y	--- EP 0 335 378 A (FUJISAWA PHARMACEUTICAL CO.) 4 October 1989 see column 4, line 8 - column 6, line 53 see figures 1,2,12-14,22	2,11-13
A	--- -/--	9

Further documents are listed in the continuation of box C.

Patent family members are listed in annex.

* Special categories of cited documents :

- *A* document defining the general state of the art which is not considered to be of particular relevance
- *E* earlier document but published on or after the international filing date
- *L* document which may throw doubts on priority claim(s) or which is cited to establish the publication date of another citation or other special reason (as specified)
- *O* document referring to an oral disclosure, use, exhibition or other means
- *P* document published prior to the international filing date but later than the priority date claimed

- *T* later document published after the international filing date or priority date and not in conflict with the application but cited to understand the principle or theory underlying the invention
- *X* document of particular relevance; the claimed invention cannot be considered novel or cannot be considered to involve an inventive step when the document is taken alone
- *Y* document of particular relevance; the claimed invention cannot be considered to involve an inventive step when the document is combined with one or more other such documents, such combination being obvious to a person skilled in the art.
- *&* document member of the same patent family

Date of the actual completion of the international search

28 April 1997

Date of mailing of the international search report

12.05.97

Name and mailing address of the ISA

European Patent Office, P.B. 5818 Patentlaan 2
NL - 2280 HV Rijswijk
Tel. (+ 31-70) 340-2040, Tx. 31 651 epo nl,
Fax (+ 31-70) 340-3016

Authorized officer

Schönleben, J

INTERNATIONAL SEARCH REPORT

International Application No
PCT/CA 97/00017

C.(Continuation) DOCUMENTS CONSIDERED TO BE RELEVANT		
Category	Citation of document, with indication, where appropriate, of the relevant passages	Relevant to claim No.
Y	WO 92 11897 A (ABBOTT LABORATORIES) 23 July 1992 see page 7, line 24 - page 9, line 21 see figures 1-7	4-6,24
A	& US 5 171 214 A cited in the application ---	8,19
X	WO 90 03536 A (BAXTER INTERNATIONAL) 5 April 1990 see page 9, line 17 - page 14, line 27 see figures 1-5	1
A	-----	9

INTERNATIONAL SEARCH REPORT

International application No.

PCT/CA 97/ 00017

Box I Observations where certain claims were found unsearchable (Continuation of item 1 of first sheet)

This International Search Report has not been established in respect of certain claims under Article 17(2)(a) for the following reasons:

1. Claims Nos.:
because they relate to subject matter not required to be searched by this Authority, namely:

2. Claims Nos.:
because they relate to parts of the International Application that do not comply with the prescribed requirements to such an extent that no meaningful International Search can be carried out, specifically:

3. Claims Nos.:
because they are dependent claims and are not drafted in accordance with the second and third sentences of Rule 6.4(a).

Box II Observations where unity of invention is lacking (Continuation of item 2 of first sheet)

This International Searching Authority found multiple inventions in this international application, as follows:

- No.1: Claims 1-10,22,23,24
Activation assembly comprising a hub.
- No.2: Claims 11-21,23
Activation assembly comprising a hub and an overcap.

1. As all required additional search fees were timely paid by the applicant, this International Search Report covers all searchable claims.
2. As all searchable claims could be searched without effort justifying an additional fee, this Authority did not invite payment of any additional fee.
3. As only some of the required additional search fees were timely paid by the applicant, this International Search Report covers only those claims for which fees were paid, specifically claims Nos.:

4. No required additional search fees were timely paid by the applicant. Consequently, this International Search Report is restricted to the invention first mentioned in the claims; it is covered by claims Nos.:

Remark on Protest

- The additional search fees were accompanied by the applicant's protest.
- No protest accompanied the payment of additional search fees.

INTERNATIONAL SEARCH REPORT

Information on patent family members

International Application No

PCT/CA 97/00017

Patent document cited in search report	Publication date	Patent family member(s)	Publication date
DE 1913926 A	24-09-70	NONE	
EP 335378 A	04-10-89	CA 1309980 A DE 68909822 D DE 68909822 T DK 169906 B ES 2050175 T FI 95438 B IE 62777 B JP 2001277 A KR 9407438 B NO 177037 B US 4936841 A	10-11-92 18-11-93 17-02-94 03-04-95 16-05-94 31-10-95 22-02-95 05-01-90 18-08-94 03-04-95 26-06-90
WO 9211897 A	23-07-92	US 5171214 A CA 2098506 A EP 0564581 A	15-12-92 27-06-92 13-10-93
WO 9003536 A	05-04-90	US 4898209 A AU 613531 B AU 4318489 A CA 1327776 A DE 68908388 T EP 0388457 A JP 3501456 T	06-02-90 01-08-91 18-04-90 15-03-94 13-01-94 26-09-90 04-04-91