

(No Model.)

2 Sheets—Sheet 1.

C. D. BINGHAM.

EQUALIZING MECHANISM FOR PAPER WINDING APPARATUS.

No. 429,497.

Patented June 3, 1890.

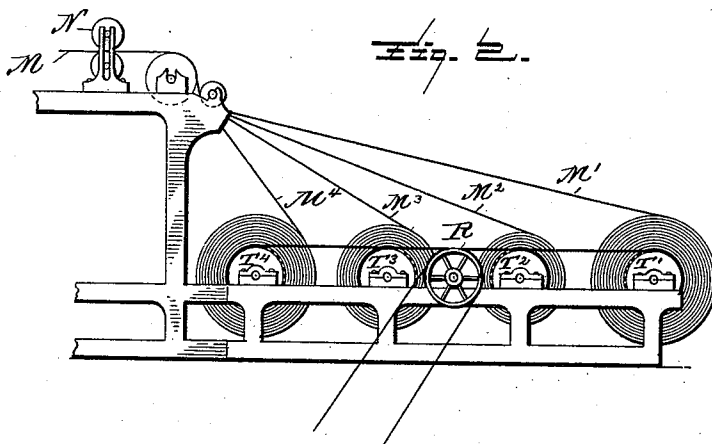
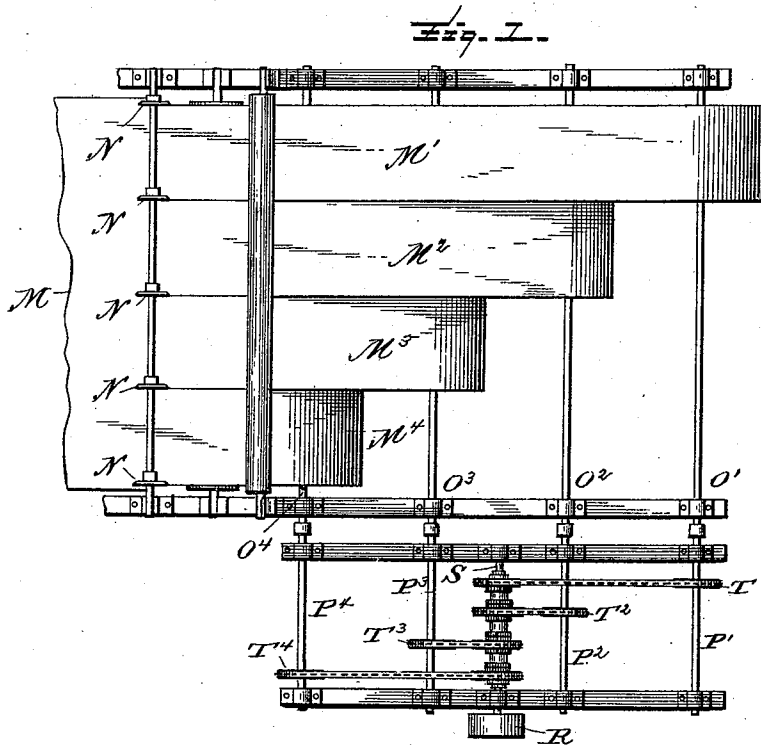

WITNESSES:

L. C. Hills
William H. Shipley

INVENTOR

Charles D. Bingham
BY
Marcellus Bailey
his ATTORNEY.

C. D. BINGHAM.

EQUALIZING MECHANISM FOR PAPER WINDING APPARATUS.

No. 429,497.

Patented June 3, 1890.

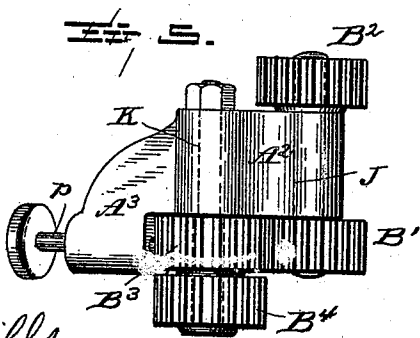
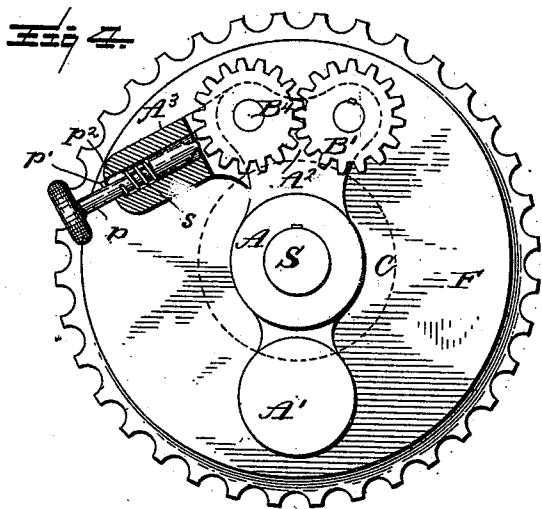
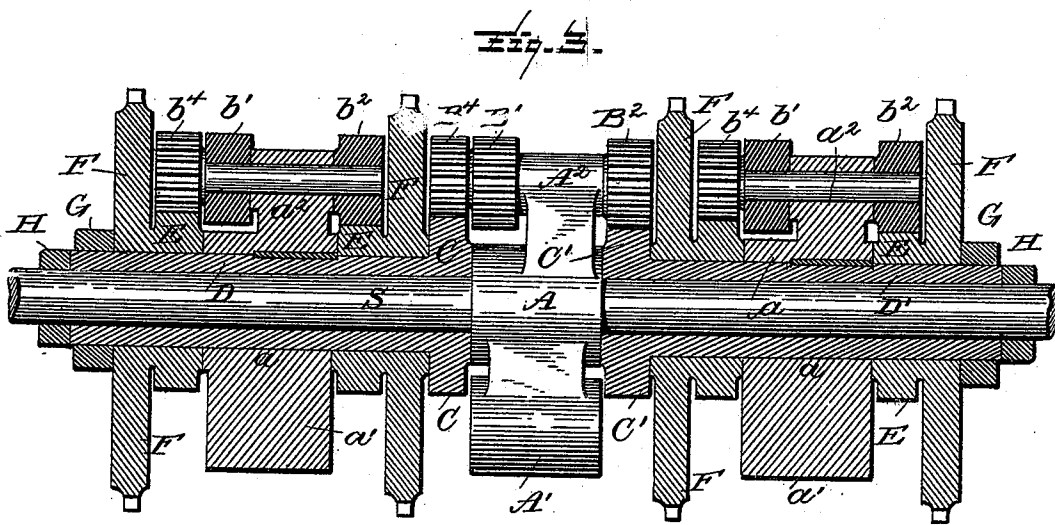

WITNESSES:

L. C. Hills.
William H. Shipley.

INVENTOR

Charles D. Bingham
 BY *Marshall Dealy*
 his ATTORNEY.

UNITED STATES PATENT OFFICE.

CHARLES D. BINGHAM, OF WATERTOWN, NEW YORK.

EQUALIZING MECHANISM FOR PAPER-WINDING APPARATUS.

SPECIFICATION forming part of Letters Patent No. 429,497, dated June 3, 1890.

Application filed February 15, 1890. Serial No. 340,621. (No model.)

To all whom it may concern:

Be it known that I, CHARLES D. BINGHAM, of Watertown, in the State of New York, have invented a certain new and useful Improvement in Equalizing Mechanism for Paper-Winding Apparatus, of which the following is a specification.

My invention relates to that part of or appendage to a paper-making machine known as the "winder," and which is the part where the finished paper is wound into rolls of desired width and diameter. In all cases when the sheet of paper as it comes from the paper-machine is divided longitudinally for the purpose of making two or more rolls from one sheet, it is necessary that each reel upon which the paper is wound should take the paper from the slitters where the sheet is divided at absolutely the same rate of speed; and unless all the rolls are maintained at exactly equal diameters the different surface speeds would produce different tensions in the sheets going onto the several rolls. It is obvious that if a roll of smaller diameter be revolved enough faster than one of a larger diameter, so that each shall have the same peripheral speed, then the paper will be wound upon each with the same degree of tension; and the object of my invention is to supply a device which accomplishes this result automatically. This feature is not broadly claimed by me, for I am aware that devices have before been invented and used to attain the same end.

The main characteristic of my invention is the arrangement of parts whereby I am enabled to assemble and concentrate the entire equalizing mechanism for any desired number of rolls upon one and the same shaft, thereby greatly economizing space and material.

The nature of my invention and the manner in which the same is or may be carried into effect can best be explained and understood by reference to the accompanying drawings, in which—

Figure 1 is a plan, and Fig. 2 is a side elevation, of the winding apparatus of a paper-machine for four rolls, the portion of the frame which carries the slitters being also represented. Fig. 3 is a longitudinal axial section, partly in elevation, of the parts of my improved equalizing mechanism. Fig. 4 is a side

elevation, partly in section, of the main driving-shaft, the parts directly secured thereto, and the devices with which they are immediately associated. Fig. 5 is a plan of the pinion-locking device in connection with the pinions which it controls. Figs. 3, 4, and 5 are upon a scale larger than Figs. 1 and 2.

Referring to Figs. 1 and 2, M is the sheet of paper as it leaves the finishing-rolls of the paper-machine. It passes between the slitters N, where it is divided into four strips of desired width, which are wound upon the reels O' O² O³ O⁴ of any suitable kind, power being communicated to the reels through couplings of any desired form, which connect the shafts of these reels with the winder-shafts P' P² P³ P⁴. The winder-shafts are revolved from the main shaft S by means of chains and sprocket-wheels, as shown; but these sprocket-wheels and chains can be replaced by gearing, belted pulleys, or any other usual appliance for transmitting power.

R is a pulley to which the primary power is applied.

Thus far there is nothing new in the machine. I proceed now to a description of the mechanism in which my invention is comprised, referring for this purpose more particularly to Figs. 3, 4, and 5.

Keyed fast to shaft S and revolving with it is the hub A, having on diametrically-opposite sides the counter-balance A' and the arm A², carrying pinions B' B² B³ B⁴. Pinions B' B² are keyed to shaft J, which is journaled in arm A², and pinion B' meshes with pinion B³. Pinions B³ B⁴ are fastened together, forming practically one pinion of double width of face and revolving upon a stud K, having its support in arm A², as shown. Pinions B² B⁴ mesh, respectively, with gears C C', the one of which is keyed fast to or formed in one with the sleeve D, and the other of which is keyed fast to or formed in one with the sleeve D'. These two sleeves are mounted independently of each other upon shaft S, and can revolve freely thereon, except as controlled or driven by the pinions B² B⁴.

To each of the sleeves D D' is keyed fast a hub a, similar to the hub A, except that they are bored large enough to fit the sleeves, and, like the latter hub, provided with a counter-balance a' and an arm a², carrying

the same arrangement of pinions b' , &c., as the arm A^2 of the primary hub A . In the drawings pinion b^3 is not shown, being obscured, as in Fig. 3, by the pinion b' , which is in front of it; but, as already remarked with reference to pinions $B^3 B^4$, the pinions $b^3 b^4$ are practically one pinion of double width of face.

Revolving freely upon the sleeves $D D'$, except as controlled by pinions $b^3 b^4$, two upon each sleeve, are gears E , which mesh, the one with pinion b^2 , the other with pinion b^4 , said gears being fastened solidly to or forming part of sprocket-wheels F . Each of these four sprocket-wheels is by a chain connected to the winder-shaft P' , &c., appropriate to it. It will be noted that throughout this arrangement I make use of spur gears and pinions, and this I prefer, because such gears and pinions can be much more easily and cheaply made, commercially, than bevel gears and pinions. Still, if desired, the latter might be used instead, in which case, in lieu, for instance, of the four pinions $B' B^2 B^3 B^4$, there would be journaled on arm A^2 upon a vertical axis a beveled pinion to mesh directly with the gears $C C'$, which of course in this event would be correspondingly beveled. By this arrangement all the equalizing devices for the several winder-shafts are assembled, supported, and move upon one and the same driving-shaft S . In this system each sprocket-wheel is a fulcrum for all the others, and the size of the gears being uniform the power communicated from shaft S to any sprocket-wheel will exactly equal that communicated from it to any other one of the set. If any three of the sprocket-wheels are held fast while the shaft S is revolved, the remaining one will revolve at four times the speed of the shaft; or, if two are held fast the remaining two will revolve at twice the speed of the shaft. The outer sprocket-wheels and their gears are kept from endwise movement on the sleeves by collars G on the latter, and the sleeves in turn are similarly confined by collars H on the shaft S .

It is obvious that the same system may be extended indefinitely—*e. g.*, to eight, sixteen, or a greater number of sprocket-wheels driving a corresponding number of reels—by increasing the number of sleeves with the necessary additional arms and gearing, still using one central shaft S only.

If it be desired at any time with a four-reel winder—such as represented to wind a less number of rolls than four—this may be done by locking one or more of the pinions, thus compelling the gears on each side of the revolving driving-arm to revolve as one. For this purpose I provide a locking device, which, preferably, is of the construction shown in section in Fig. 4 and in plan in

Fig. 5. This device consists of a pin p , capable of longitudinal and rotary movement in a barrel A^3 on arm A^2 . The inner end of this pin projects through the inner end of the barrel and is shaped to fit into the spaces between the teeth of the pinion B^4 . The pin is spring-pressed toward the pinion by a spiral spring s in the barrel, encircling the pin and confined between a shoulder on the latter and the outer end of the barrel. The pin is provided with a head or button, by which it may be pulled back out of engagement with the pinion; and it has on it a laterally-projecting stud or spline p' , which moves in a groove p^2 in the barrel. When the pin is pulled out far enough to bring the spline outside of the groove, it can be held in a retracted position by turning it so as to throw the spline out of register with the groove. As soon as the spline is brought again into register with the groove the pin is free to again move inward into engagement with the pinion. I do not recommend, however, that a four-reel winder be used for winding three rolls, except temporarily, as it is obvious that such an arrangement winds one of the rolls with the same tension as both of the others, or, in other words, with twice the tension of either of the others. So for winding three rolls I prefer to supply a three-reel winder, which has the third reel driven by a gear and pinion of such relative proportion to the gears and pinions driving the other two reels that the third reel will have a tension upon the paper one-half that of the other two or the same as either of the other two.

Having described my invention and the best way now known of carrying the same into effect, what I claim, and desire to secure by Letters Patent, is—

The combination, with the primary driving-shaft and the primary driving-arm and gearing carried by and revolving with the same, of separate and independent sleeves or tubular secondary shafts mounted to revolve freely on said primary shaft, gears fixed to said sleeves to mesh with the gearing of the driving-arm on the primary shaft, secondary driving-arms—one for each sleeve—fixed thereto, gearing carried by said secondary driving-arms, respectively, and gears mounted to revolve freely on said sleeves and engaging the gearing carried by the secondary driving-arms, under the arrangement and for joint operation substantially as hereinbefore set forth.

In testimony whereof I have hereunto set my hand.

CHARLES D. BINGHAM.

Witnesses:

EDGAR S. SHELLEY,
STUART D. LANSING.