

AUSTRALIA
Patents Act 1990

NOTICE OF ENTITLEMENT

- We 1) Jarmo Uolevi LEPPANEN
2) Roger Robarts BRIGGS
- of 1) 11 JUNCTION ROAD
INDUSTRIES NORTH, GERMISTON
TRANSVAAL
REPUBLIC OF SOUTH AFRICA
2) 23 LEYES LANE
KENILWORTH
WARWICKSHIRE CU8 20D
ENGLAND

being the applicant(s) and nominated person(s) in respect of an application for a patent for an invention entitled ROCK DRILL (Application No. 65428/94), state the following:

1. The nominated person(s) has/have, for the following reasons, gained entitlement from the actual inventor(s):

THE NOMINATED PERSONS ARE THE ACTUAL
INVENTORS.

2. The nominated person(s) has/have, for the following reasons, gained entitlement from the applicant(s) listed in the declaration under Article 8 of the PCT:

THE APPLICANTS AND NOMINATED PERSONS ARE
THE BASIC APPLICANTS.

3. The basic application(s) listed in the declaration under Article 8 of the PCT is/are the first application(s) made in a Convention country in respect of the invention.

DATED: 18 October 1995
Jarmo Uolevi LEPPANEN
Roger Robarts BRIGGS

GRIFFITH HACK & CO.



Patent Attorney for and
on behalf of the applicant(s)



AU9465428

(12) PATENT ABRIDGMENT (11) Document No. AU-B-65428/94
(19) AUSTRALIAN PATENT OFFICE (10) Acceptance No. 672904

(54) Title
ROCK DRILL

International Patent Classification(s)

(51)⁵ E21B 006/00

(51)⁶ E21B 003/02

(21) Application No. : 65428/94

(22) Application Date : 21.04.94

(87) PCT Publication Number : WO94/24403

(30) Priority Data

(31) Number	(32) Date	(33) Country
93/2778	21.04.93	ZA SOUTH AFRICA

(43) Publication Date : 08.11.94

(44) Publication Date of Accepted Application : 17.10.96

(71) Applicant(s)
JARMO UOLEVI LEPPANEN; ROGER ROBARTS BRIGGS

(72) Inventor(s)
JARMO UOLEVI LEPPANEN; ROGER ROBARTS BRIGGS

(74) Attorney or Agent
GRIFFITH HACK , GPO Box 1285K, MELBOURNE VIC 3001

(56) Prior Art Documents

US 4842080

US 4962681

EP 408987

(57) Claim

1. A percussive rock drill (10) which includes a main body (16) with a chamber (38;38A) which is formed in the main body, a rotation module (14) which includes a gear housing (28) which is mounted in the chamber (38;38A), gear means (32;34) in the gear housing, a drill shank (18) which is engaged with the gear means (32;34) and which is rotatable and reciprocable relatively to the gear housing (28), and a percussion module (23), characterised in that the percussion module (23) is located in the main body (16) and in that the rotation module (14) is positioned at one end of the percussion module (23).

- 1 -

ROCK DRILL

BACKGROUND OF THE INVENTION

5 This invention relates to a rock drill and more particularly to the mounting of a rotation module to the body of a rock drill.

10 Rock drills known to the applicant consist of various sections which are bolted together. These sections normally include at least a drill rod flushing section, a rotation gear housing section and a percussion section. The drill, assembled from the aforementioned parts, is bolted to a drill cradle which slides on a drill feed
15 during drilling.

This kind of arrangement simplifies the construction and lowers the cost of manufacture. On the other hand the rock drill is more vulnerable to damage and its life
20 expectancy is reduced.

In percussive drilling a heavy drill piston hammers the drill steel via a drill shank at a frequency of from 40 to 60 Hz. The resulting vibrations can cause the

- 2 -

connecting bolts to become loose and this in turn, without maintenance and tightening up, will result in heavy maintenance expenses or, at worse, ruin the drill.

5 Loose bolts also cause wear on opposing surfaces between adjacent sections. The worn surfaces or the loose sections cause the percussion section to move out of alignment with the drill shank. The impact surface between the piston and the shank may then be angled and
10 this can cause the shank or the piston to break. If the piston breaks, the percussion mechanism, which is expensive, is invariably destroyed and the hydraulic oil is contaminated.

15 The applicants are aware of an arrangement for mounting a rotation element in a drilling machine, described in the specification of U.S.A. patent No.4842080, wherein the rotation element has stepped bearing surfaces which permit the rotation element to be mounted to a body in a
20 simplified manner. The rotation element may be detached from the body by removal of a single end cover. With this arrangement rotation machinery is mounted on an outer surface of the body and imparts a rotational drive via a gear ring to the rotation element. The advantage of
25 having a separate rotation module is lost.

Similarly, in the specification of South African patent No.87/2885 (counterpart to Finnish application No.861938) there is disclosed a rotation bushing mounted directly
30 inside the body of a drill. Again the advantage of a separate rotation module is lost.

SUMMARY OF THE INVENTION

The invention is concerned with a rock drill of relatively simplified construction which embodies important manufacturing and maintenance aspects.

5 The invention provides a percussive rock drill which includes a main body with a chamber which is formed in the main body, a rotation module which includes a gear housing which is mounted in the chamber, gear means in the gear housing, a drill shank which is engaged with the
10 gear means and which is rotatable and reciprocable relatively to the gear housing, and a percussion module, which is located in the main body, the rotation module being positioned at one end of the percussion module.

15 The gear housing may include a flange which is secured directly to one end of the body. Alternatively the flange may be dispensed with.

20 A flushing module may be located on an outer side of the rotation module and may be secured directly to the main body or indirectly, via the flange of the gear housing.

25 The rotation module may be engageable with drive means extending from at least one rotation motor which is mounted at a second end of the body which is remote from the end to which the aforementioned flange is secured.

30 Alternatively at least one rotation motor is mounted directly to the rotation module, for example to the flange of the gear housing.

BRIEF DESCRIPTION OF THE DRAWINGS

The invention is further described by way of example with



AMENDED SHEET
IPEA/EP

- 5 -

The flushing module 12 is of substantially conventional construction and includes a passage 24 which extends through the module, and a mounting flange 26.

5 The rotation module 14 includes a gear housing 28 and a mounting flange 30. Rotationally mounted to the housing 28 are a gear mechanism 32, and a drive gear 34 which is meshed with the gear mechanism 32.

10 The main body 16 has an inner chamber 21 which houses the percussion cartridge or module 23. The main body is elongate and at a first end 36 is formed with chambers 38 and 38A. At a second end 40, which is remote from the first end, the body is adapted to receive the rotation
15 motor 22. One end 25 of the module 14 directly abuts an opposing end of the module 23 closing the chamber 21 and retaining the module 23 in position.

A shaft 42 extends from the motor 22. The drive gear or
20 pinion 34 of the rotation module is connected to the shaft 42 in any suitable way, for example by means of a spline connection 41. This is not limiting and any appropriate means of connecting the shaft to the pinions may be used.

25 The shank 18 includes a pinion 44 to transfer rotational movement from the gear mechanism 32.

30 Figures 2 and 3 illustrate the rock drill fully assembled. The rotation motor 22 is bolted to the second end 40 of the main body 16. The shaft 42 extends through the body and the pinion 34, attached to the rotation module 14, is located in the lower chamber 38A shown in Figure 1, meshing with the gear mechanism 32.

- 6 -

The rotation module 14 is secured to the body 16 by locating the housing 28 and the pinion 34 inside the chambers 38 and 38A. The flange 30 sits against the first end 36 of the body. The housing 28 is fully encapsulated in the chamber 38.

The pinion 44 of the shank 18 is meshed with the gear mechanism 32 and the shank 18 is located in the passage 24. The flange 26 of the flushing module mates with the flange 30 and the flushing module and the rotation module are secured to the body 16 by means of bolts 46.

The rock drill of the invention has the advantage that the gear housing is separate and replaceable and is well guided and supported by and locked to the main body 16. Vibrations and radial and axial forces which are exerted on the gear housing during drilling, from the drill shank 18, are thus dampened by the main body. The possibility of the gear housing becoming loose and misalignment with the main body 16 is thus reduced. Misalignment will cause unlevelled percussion surfaces between the reciprocating piston and the drill shank 18, over stressing all the components on the rock drill, and particularly along the percussive drilling piston, its bearings and the drill shank 18.

It is to be noted that the gear housing is not connected to the drill cradle 20. The length of the body 16 can be maximized to improve the connection of the body 16 to the cradle and to reduce vibrations which are exerted on the percussion section in the body 16. Thus the vibrations, forces and shock loading which arise during use are taken up mainly by the solid heavy main body 16.

- 7 -

The housing 28 of the rotation module 14 can be made without the flange 30 in which event the module, once located in the chambers 38 and 38A, is kept in position by the reaction forces which arise between the housing 28 and the main body 16 and by the flange 26 which is bolted directly to the body 16. This modification reduces to one the number of mating surfaces in the assembled rock drill.

Another possible variation is shown in Figure 4 which depicts the rotation module 14 with an extended flange 30 which is adapted to receive the rotation motor 22 which is directly fixed to the flange. Rotational movement from the rotation motor 22 is transferred to the gear mechanism 32 by means of the drive gear 34. The drive gear 34 is located on the rear side of the flange 30 (see Figure 4), is connected to the motor 22, and meshes directly with the gear mechanism 32.

CLAIMS

1. A percussive rock drill (10) which includes a main body (16) with a chamber (38;38A) which is formed in the main body, a rotation module (14) which includes a gear housing (28) which is mounted in the chamber (38;38A), gear means (32;34) in the gear housing, a drill shank (18) which is engaged with the gear means (32;34) and which is rotatable and reciprocable relatively to the gear housing (28), and a percussion module (23), characterised in that the percussion module (23) is located in the main body (16) and in that the rotation module (14) is positioned at one end of the percussion module (23).
2. A rock drill according to claim 1 characterized in that at least the gear housing (28) is totally encapsulated in the chamber.
3. A rock drill according to claim 1 or 2 characterized in that the gear housing (28) includes a flange (30) which is secured directly to the main body (16).
4. A rock drill according to any one of claims 1 to 3 characterized in that it includes at least one rotation motor (22) mounted to the main body, the rotation module (14) being engaged with drive means (41;42) extending from the rotation motor (22).
5. A rock drill according to any one of claims 1 to 3 characterized in that it includes at least one rotation motor (22) which is mounted directly to the rotation module (14) (Figure 4).



AMENDED SHEET
IPEA/EP

6. A rock drill according to any one of claims 1 to 5 characterized in that it includes a flushing module (12) which is located on an outer side of the rotation module (14).

5

7. A rock drill according to any one of claims 1 to 6 characterized in that it includes a cradle (20) to which the main body (16) is fixed.

10

8. A rock drill according to claim 1 characterised in that the rotation module (14) is mounted with a first side of the rotation module (14) on one side of the percussion module (23), in that a flushing module (12) is mounted on a second side of the rotation module (14), and

15

in that at least one rotation motor (22) is provided for driving the rotation module (14).



AMENDED SHEET
IPEA/EP

1/2

65428/94

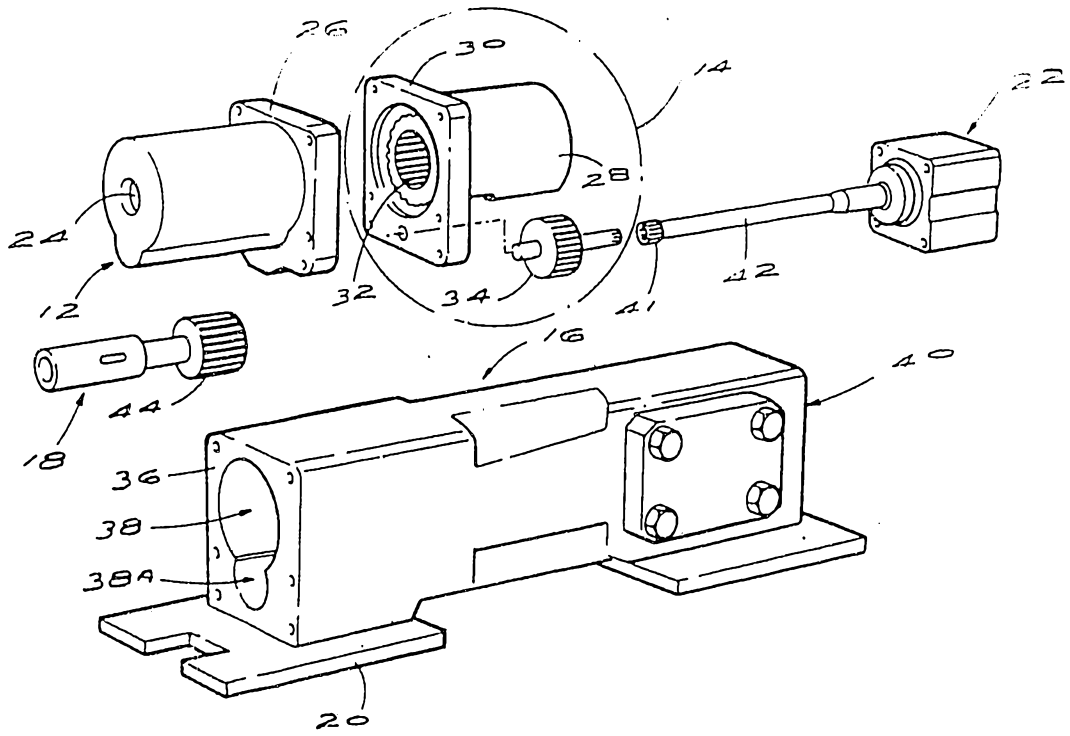

FIG 1

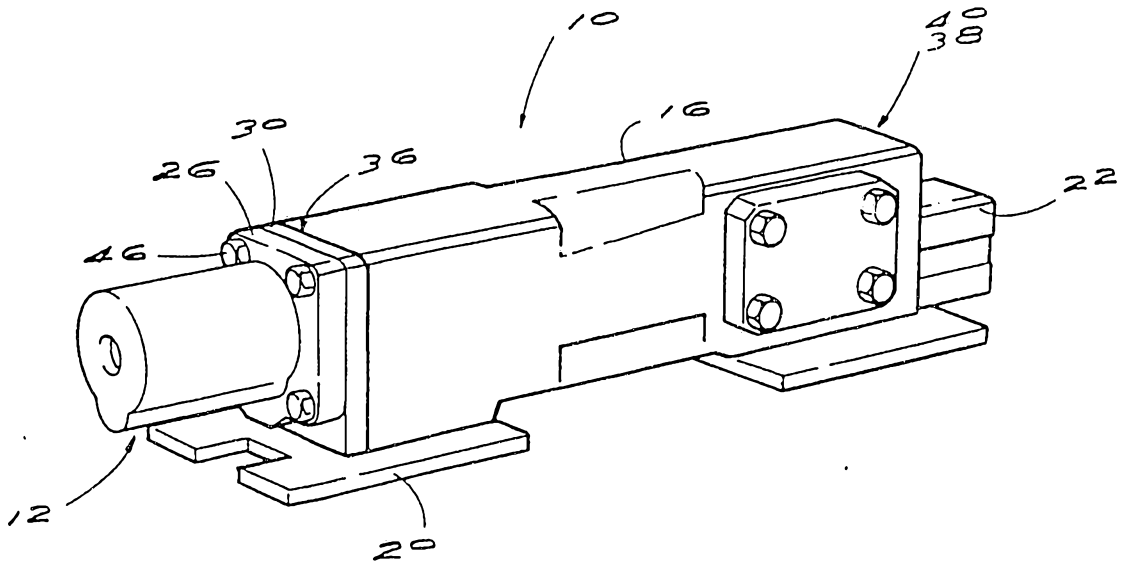
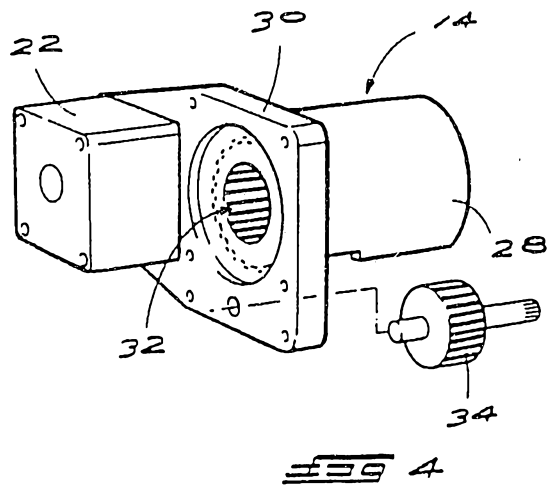
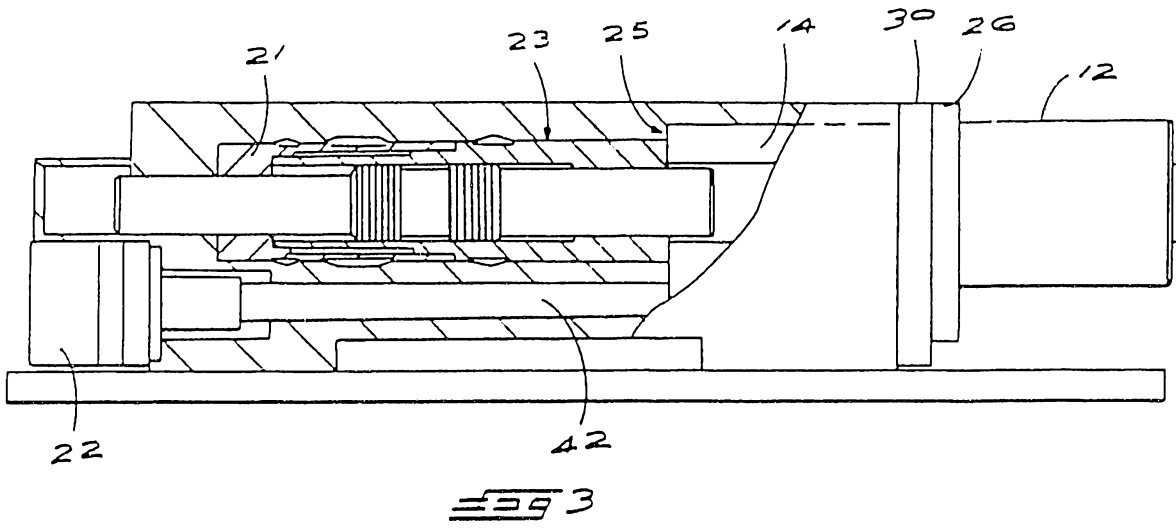

FIG 2

2/2



INTERNATIONAL SEARCH REPORT

International Application No.
PCT/GB 94/00851

A. CLASSIFICATION OF SUBJECT MATTER IPC 5 E21B6/00 B25F5/02		
According to International Patent Classification (IPC) or to both national classification and IPC		
B. FIELDS SEARCHED Minimum documentation searched (classification system followed by classification symbols) IPC 5 E21B B25D B25F B23B B23Q		
Documentation searched other than minimum documentation to the extent that such documents are included in the fields searched		
Electronic data base consulted during the international search (name of data base and, where practical, search terms used)		
C. DOCUMENTS CONSIDERED TO BE RELEVANT		
Category*	Citation of document, with indication, where appropriate, of the relevant passages	Relevant to claim No.
X	EP,A,0 408 987 (KRESS) 23 January 1991	1,2,5
Y	see abstract; claim 1; figures 1-3 ---	3,4
X	US,A,4 962 681 (YANG) 16 October 1990 see column 2, line 47 - line 68; figure 3 ---	1,2,5
Y	US,A,3 357 275 (GREEN) 12 December 1967 see figures ---	3,4
A	US,A,5 060 734 (ANDERSON) 29 October 1991 see abstract; figures ---	1,9
A	US,A,3 858 666 (BAILEY) 7 January 1975 see abstract; figures ---	1,9
A	US,A,4 842 080 (HEINONEN) 27 June 1989 cited in the application see abstract; figures -----	1,9
<input type="checkbox"/> Further documents are listed in the continuation of box C. <input checked="" type="checkbox"/> Patent family members are listed in annex.		
* Special categories of cited documents : "A" document defining the general state of the art which is not considered to be of particular relevance "E" earlier document but published on or after the international filing date "I" document which may throw doubts on priority claim(s) or which is cited to establish the publication date of another citation or other special reason (as specified) "O" document referring to an oral disclosure, use, exhibition or other means "P" document published prior to the international filing date but later than the priority date claimed "T" later document published after the international filing date or priority date and not in conflict with the application but cited to understand the principle or theory underlying the invention "X" document of particular relevance; the claimed invention cannot be considered novel or cannot be considered to involve an inventive step when the document is taken alone "Y" document of particular relevance; the claimed invention cannot be considered to involve an inventive step when the document is combined with one or more other such documents, such combination being obvious to a person skilled in the art. "&" document member of the same patent family		
Date of the actual completion of the international search <p style="text-align: center; font-size: 1.2em;">3 August 1994</p>		Date of mailing of the international search report <p style="text-align: center; font-size: 1.2em;">08.08.94</p>
Name and mailing address of the ISA European Patent Office, P.B. 5818 Patentlaan 2 NL - 2280 HV Rijswijk Tel. (+31-70) 340-2040, Tx. 31 651 cpo nl, Fax: (+31-70) 340-3016		Authorized officer <p style="text-align: center; font-size: 1.2em;">Weiland, T</p>

INTERNATIONAL SEARCH REPORT

Information on patent family members

International Application No

PCT/GB 94/00851

Patent document cited in search report	Publication date	Patent family member(s)	Publication date
EP-A-0408987	23-01-91	DE-A- 3923421	24-01-91
		DE-A- 4004464	24-01-91
		EP-A- 0408985	23-01-91
		EP-A- 0408986	23-01-91
		EP-A- 0408988	23-01-91
		EP-A- 0608916	03-08-94
		JP-A- 3139152	13-06-91
		JP-A- 3131481	05-06-91
		JP-A- 3150057	26-06-91
		US-A- 5170851	15-12-92
		US-A- 5138243	11-08-92
US-A- 5196747	23-03-93		
US-A-4962681	16-10-90	NONE	
US-A-3357275		NONE	
US-A-5060734	29-10-91	NONE	
US-A-3858666	07-01-75	AU-B- 467027	13-11-75
		AU-A- 6058573	27-03-75
		CA-A- 975350	30-09-75
US-A-4842080	27-06-89	AT-A- 111787	15-07-94
		AU-B- 594455	08-03-90
		AU-A- 7213887	12-11-87
		CA-A- 1297868	24-03-92
		CH-A- 671916	13-10-89
		DE-A- 3714884	12-11-87
		FR-A, B 2598460	13-11-87
		GB-A, B 2190333	11-11-87
		JP-A- 62288291	15-12-87
		SE-A- 8701895	10-11-87
		ZA-A- 8703129	26-10-87