

Feb. 4, 1930.

S. Z. DE FERRANTI

1,745,983

HIGH VOLTAGE ELECTRIC TRANSFORMER

Filed Sept. 10, 1925

2 Sheets-Sheet 1

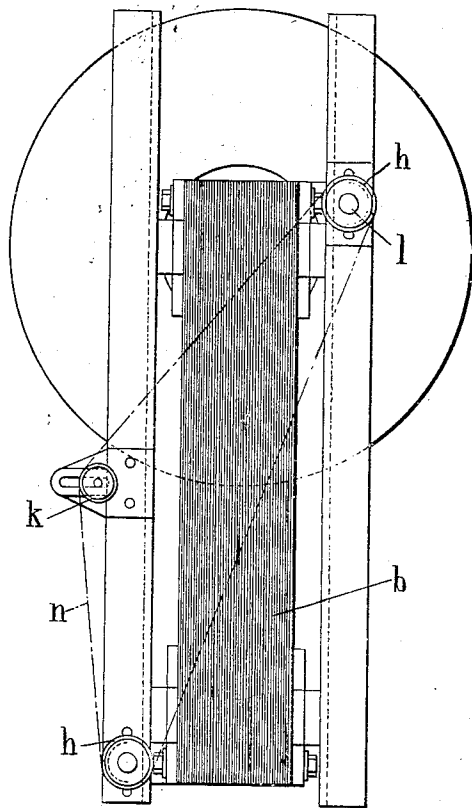

Fig. 1.

INVENTOR  
S. Z. De Ferranti  
By marks & Clerk  
attys.

Feb. 4, 1930.

S. Z. DE FERRANTI

1,745,983

HIGH VOLTAGE ELECTRIC TRANSFORMER

Filed Sept. 10, 1925

2 Sheets-Sheet 2

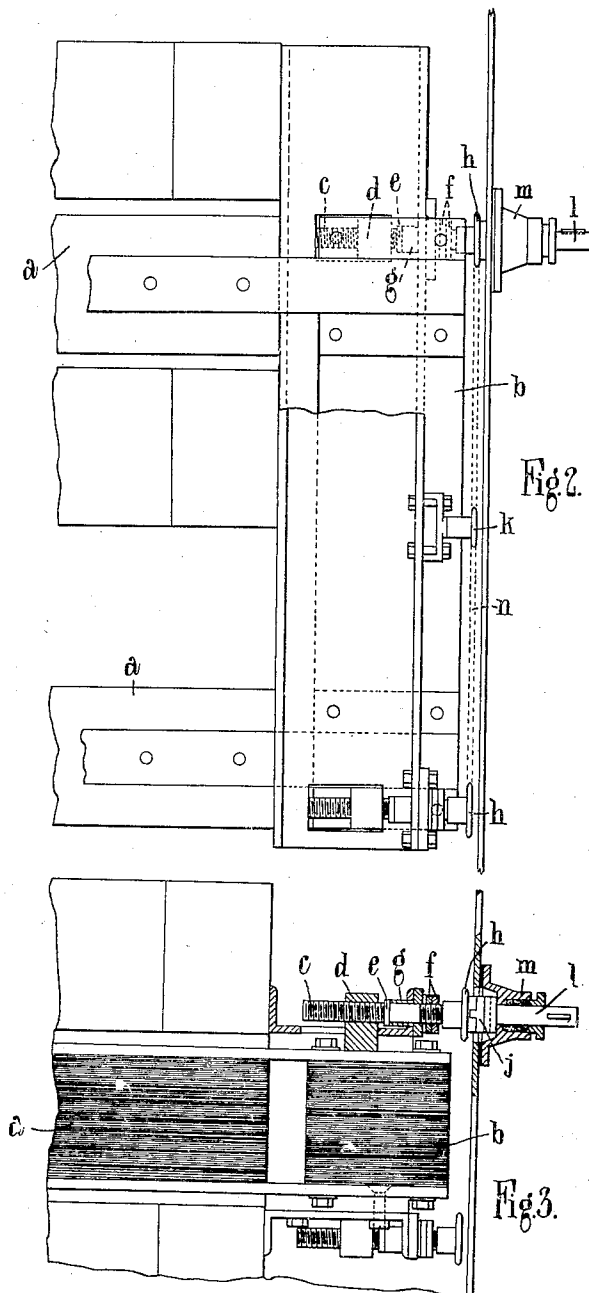

Fig. 2.

Fig. 3.

INVENTOR  
S. Z. De Ferranti  
By Marko & Clark  
attys.

# UNITED STATES PATENT OFFICE

SEBASTIAN ZIANI DE FERRANTI, OF HOLLINWOOD, ENGLAND, ASSIGNOR TO FERRANTI, LIMITED, OF HOLLINWOOD, ENGLAND

## HIGH-VOLTAGE ELECTRIC TRANSFORMER

Application filed September 10, 1925, Serial No. 55,572, and in Great Britain October 21, 1924.

In very high voltage electric transformers as made principally for electrical testing and experimenting the self-capacity of the transformer results in a considerably leading power factor which necessitates the provision of adequate plant capacity to supply the idle current. The power factor is largely varied by the frequency at which it is necessary to work for the particular test, and is also affected by the capacity of the system upon which tests are being made.

The object of my present invention is to reduce the amount of idle current required in such apparatus.

The invention consists briefly in the provision in a high voltage electric transformer of a magnetic path of variable reluctance whereby the idle current necessitated may be maintained as small as possible under varying conditions of usage of the transformer.

Referring to the accompanying diagrammatic drawings:—

Figure 1 shows an end elevational view of a convenient construction in accordance with the present invention.

Figure 2 is a side elevational view corresponding to Figure 1, but to a larger scale.

Figure 3 is a fragmental cross-sectional view.

According to a convenient manner of carrying my invention into effect, as illustrated by way of example in Figures 1 to 3, I construct a transformer in the ordinary way with a yoke *a*, but make the yoke end *b* movable so as to be able to vary the air gap according to the circumstances under which the transformer is being used at any particular time. The movement of the yoke end *b* is effected by screws *c* which engage threaded blocks *d* attached rigidly to the yoke end. The screws *c* are provided with collars *e* and nuts *f* which locate the screws in bearings *g* and each carries a sprocket wheel *h*. An endless chain *n* couples the two sprockets, a jockey sprocket *k* serving

as convenient tensioning means, and one of the sprockets is coupled by an Oldham coupling *j* to an operating spindle *l* which passes through a stuffing box *m*.

I have described above convenient means for moving the yoke of the transformer, but any means of varying the reluctance of the magnetic circuit at will to produce the desired results is included in this invention.

My invention has special advantages in its application to transformers coupled in cascade. In this case one or all of the transformers in the series may be provided with magnetic circuits of variable reluctance. Where it is desired to change the adjustment when the transformers are at work, insulated connecting handles may be provided to operate the mechanism. The iron of the core or yokes is firmly clamped and keyed to the carrying means, so that the forces set up in the magnetic circuit may be properly dealt with by the adjusting mechanism and so that no undue displacement from the regulated position will take place.

Having now described my invention, what I claim as new and desire to secure by Letters Patent is:—

1. In an electrical transformer designed to produce an extremely high voltage, windings producing a high internal capacity in said transformer and causing a leading power factor and means providing an adjustable magnetic circuit adapted to neutralize said capacity.

2. In an electrical transformer for extremely high voltages that would normally produce in its exciting circuit a leading power factor due to its internal capacity, the combination of a magnetic circuit and means to adjust the reluctance of said magnetic circuit to neutralize said effect.

3. The method of reducing the leading power factor in high voltage electric transformers possessing normally an inherent leading power factor consisting in varying the

reluctance of the magnetic path of the transformer.

4. In a high voltage electrical transformer, including in its exciting and output circuits means adapted to produce a leading current in the exciting circuit, a magnetic circuit adjustable to neutralize the effect of said means.

In testimony whereof I have signed my name to this specification.

SEBASTIAN ZIANI DE FERRANTI.

15

20

25

30

35

40

45

50

55

60

65