

Nov. 26, 1935.

G. F. FISHER

2,022,031

DISPENSING CONTAINER

Filed Oct. 17, 1934

2 Sheets-Sheet 1

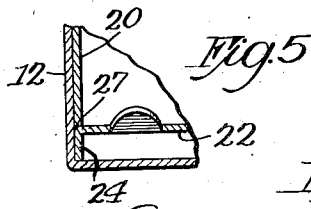
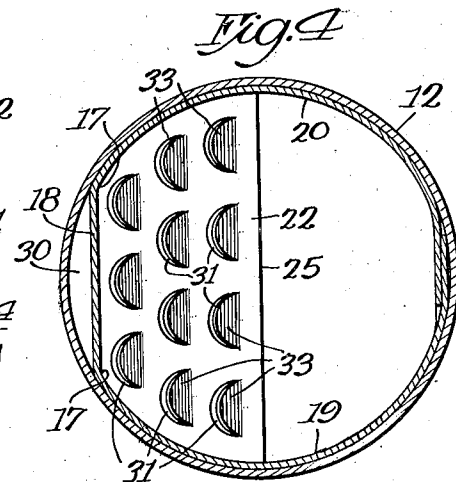
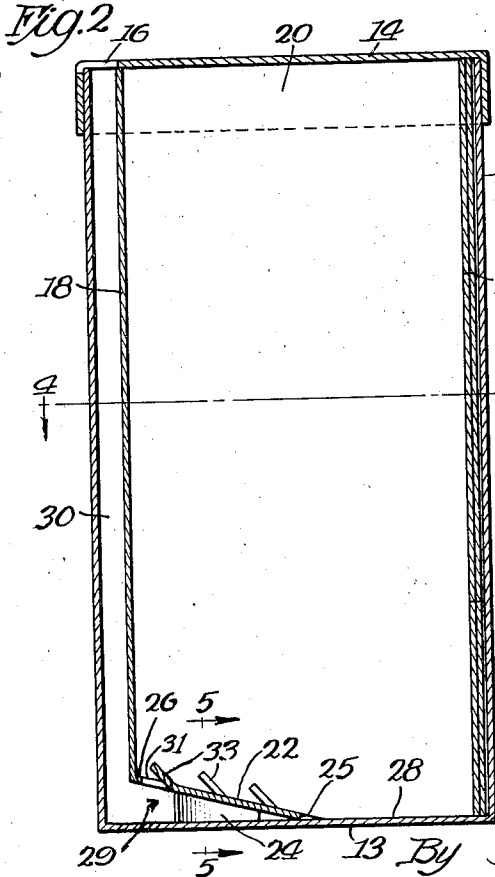
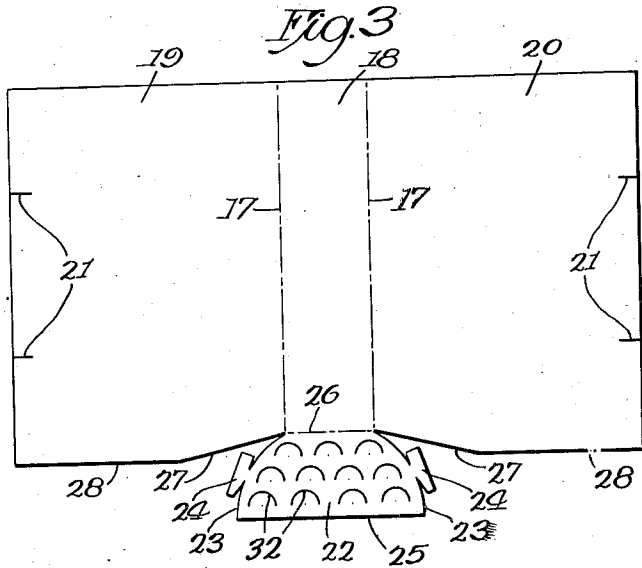
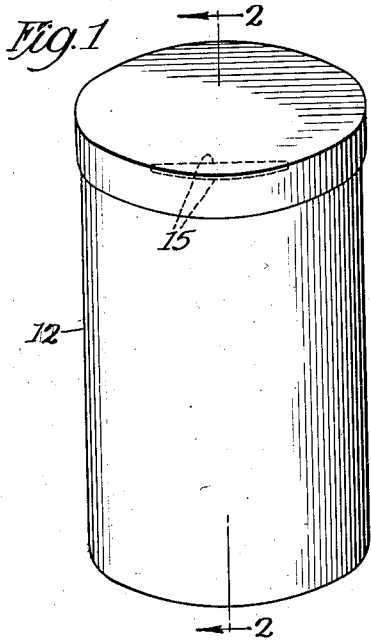

Inventor  
George F. Fisher

By Fisher, Clapp, Soans & Park attys.

Nov. 26, 1935.

G. F. FISHER

2,022,031

DISPENSING CONTAINER

Filed Oct. 17, 1934

2 Sheets-Sheet 2

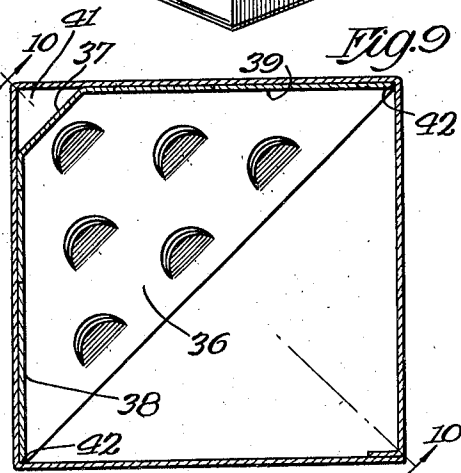
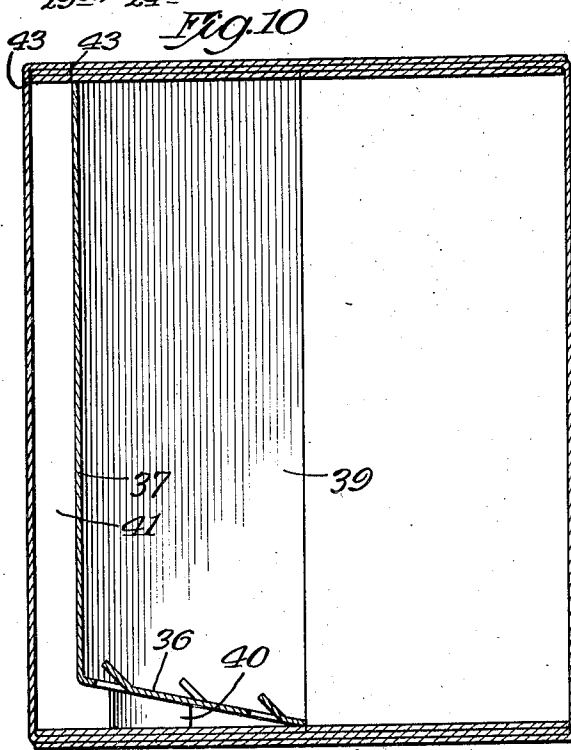
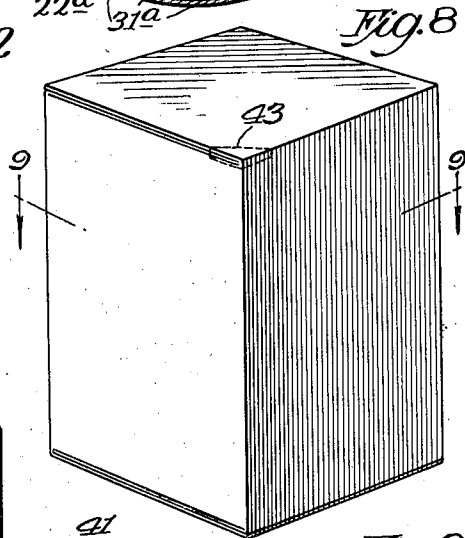
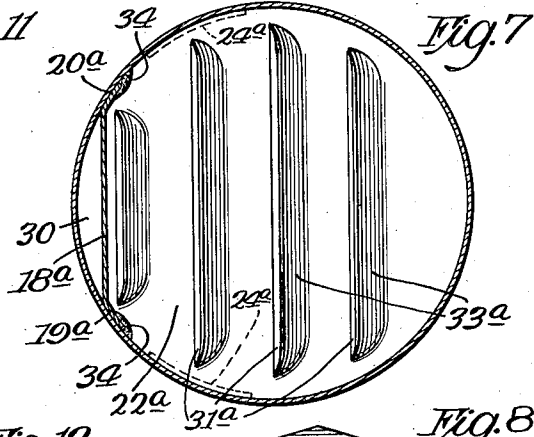
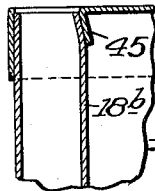
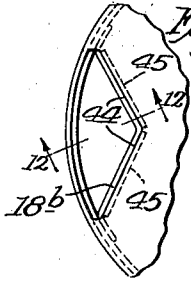
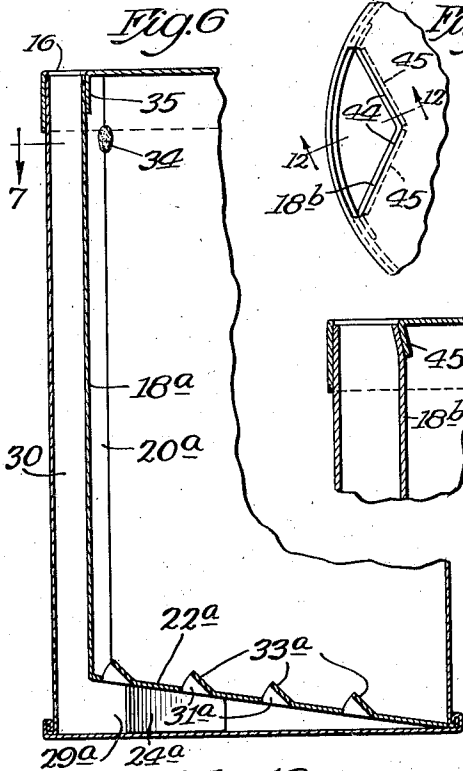

Inventor  
George F. Fisher  
By  
Fisher, Clapp, Soans & Pond  
Attys

# UNITED STATES PATENT OFFICE

2,022,031

## DISPENSING CONTAINER

George F. Fisher, Lake Forest, Ill.

Application October 17, 1934, Serial No. 748,682

7 Claims. (Cl. 221-98)

This invention relates to improvements in a dispensing container and more particularly to a container which is provided with an arrangement for successively dispensing measured quantities of the content of the container.

The main objects of the invention are to provide an arrangement in a container which will be effective to accurately measure a predetermined quantity of material and set such measured quantity apart from the main bulk of the material in the container for dispensing of such measured quantity; and to provide such an arrangement which will be simple and inexpensive to produce but which will nevertheless be efficient and durable.

Other objects and advantages of the invention will be understood by reference to the following specification and accompanying drawings (2 sheets), wherein there are illustrated three forms of the dispensing container embodying the invention.

In the drawings:

Fig. 1 is a perspective of a cylindrical paper-board container embodying the invention.

Fig. 2 is a section on the line 2-2 of Fig. 1.

Fig. 3 is a plan of an insert element in its blank form.

Figs. 4 and 5 are sections on the lines 4-4 and 5-5 respectively, of Fig. 2.

Fig. 6 is a section similar to Fig. 2, but showing a metallic construction.

Fig. 7 is a section on the line 7-7 of Fig. 6.

Fig. 8 is a perspective of a rectangular container embodying the invention.

Fig. 9 is a section on the line 9-9 of Fig. 8.

Fig. 10 is a section on the line 10-10 of Fig. 9.

Fig. 11 is a fragmentary plan showing a modification, and Fig. 12 is a section on the line 12-12 of Fig. 11.

Referring now to the drawings, the container illustrated in Figs. 1 to 5 inclusive, embodies an outer or side wall 12, a bottom wall 13 and top 14, which parts may be formed and assembled substantially in accordance with conventional paper-board container practice. The top 14 is illustrated in this instance as being in the form of a flanged cap element fitting over the upper end portion of the side wall 12 and it is provided adjacent one edge with perforated or scored lines indicated at 15 to facilitate tearing out of a portion of the top to provide a dispensing opening such as indicated at 16 in Fig. 2.

An insert element formed of cardboard is shaped substantially as indicated in Fig. 3, such insert element being scored or creased as indi-

cated at 17, 17 to facilitate bending so as to provide an inner wall portion 18 which substantially retains its normally flat condition. The sidewise extensions 19 and 20 of the inner wall element 18 are slitted at their outer edges as indicated at 21, 21, and they are of such width that they may be bent to substantially cylindrical form to snugly fit inside of the container wall 12. The slits 21 in the free outer edges of the wings or extensions 19 and 20 serve to permit interlocking of said edges and causing the central portions of said free edge portions, i. e., the portions between the companion slits 21, to overlap in one direction while causing the marginal portions outwardly of said slits to overlap in the opposite direction. This arrangement serves to maintain the extensions 19 and 20 in their distended condition in which they snugly fit the container as indicated in Fig. 4.

Formed integrally with the inner wall member 18 and connected with its lower end is an auxiliary bottom element 22 which is provided with rounded edge portions 23, 23 designed to fit the interior of the wall 12 and with ears or legs 24 integrally connected with said rounded edge portions of the auxiliary bottom element. In this instance the bottom element 22 is shown as being of such size that it extends over only approximately one-half of the area of the container bottom 13 so that its outer or free end 25 is substantially straight. By reference to Fig. 2, it will be seen that the auxiliary bottom element 22 is folded along a score or crease line 26 and its junction with the lower end of the inner wall 18 and that said end of the inner wall 18 is spaced upwardly from the bottom 13 of the container. The ears or legs 24 are bent downwardly so as to engage the bottom 13 of the container thereby to support said auxiliary bottom against collapsing under the weight of the contents of the container. The arrangement is also preferably such that the inclined lower edge portions 27, 27 of the extensions 19 and 20 overlie the respectively adjacent margins of the bottom element 22, as indicated in Fig. 5. The lower edge portions 28, 28 of the said extensions 19 and 20 preferably engage the bottom of the container. The upper edge of the insert blank is, in this instance, substantially straight and the height of the insert is such that its upper end will engage the top wall when its lower end rests on the bottom wall. It will be seen that the auxiliary bottom element 22 is thus effectively locked in inclined position relative to the bottom 13 and that a chamber 29 is formed in the bottom of the container. The

spacing of the inner wall element 18 from the container wall 12 serves to provide a passageway or conduit 30 which communicates with said chamber 29 and with the dispensing opening 16.

6 The auxiliary bottom element 22 is provided with an opening or openings such as indicated at 31, said openings being preferably formed by slitting said bottom element as indicated at 32 in Fig. 3, and then bending the ears formed by  
10 said slits upwardly to substantially the position indicated in Fig. 2.

It will be understood that the blank from which the insert element is made is, when made of cardboard, of such thickness and stiffness that the  
15 ers or louvers 33 formed as above explained will maintain themselves in said position. Said louvers serve to obstruct the flow of material from the container through the openings 31 into the chamber 29 when the container is tilted to  
20 pour a measured quantity of the material from the chamber 29 through the conduit 30 and outlet 16. The said louvers are an important factor in obtaining accuracy of the measured quantities dispensed and it will be seen that because of their  
25 angular relationship to the auxiliary bottom, they tend to divert material from the openings 31 when the container is tilted in the direction for dispensing material therefrom.

Referring now to Figs. 6 and 7, the container structure there shown is of metallic construction and it embodies a more or less conventional  
30 outer container and a metallic insert which includes an inner wall portion 18a and an auxiliary bottom 22a. The inner wall element 18a is equipped with relatively narrow sidewise  
35 extensions or flanges 19a and 20a, respectively, which flanges are bent relative to the wall portion 18a and curved to fit against the curved surface of the container wall. A small solder fastening indicated at 34 may be provided near the  
40 upper end at each side of the insert for effectively holding the same in fixed relation to the container.

In this instance the auxiliary bottom wall 22a is shown as fitting across the entire area of the  
45 container bottom (except for the area of the conduit 30), so that a chamber 29a of larger capacity is formed. Instead of small semi-circular openings and louvers 31 and 33 respectively, the auxiliary bottom, in this instance, is  
50 provided with elongated openings and louvers such as indicated at 31a and 33a respectively. It will be understood that the periphery of the auxiliary bottom 22a should preferably be such as to fit snugly within the container body, so that it is  
55 not laterally shiftable within the container and so that it serves to hold the lower end of the inner wall element 18a in fixed position.

Instead of removing the metal of the container top to form the dispensing opening 16, such metal  
60 may be turned downwardly to form a lip 35 which may fit either inwardly or outwardly of the inner wall element 18a. In Fig. 6, the lip is shown as fitting inside of the inner wall element and thereby serves to assist the solder spots  
65 34 to support the inner wall element in its proper position. The lip 35 also helps to prevent leakage of material between the top wall and the upper end of the inner wall element.

70 It will, of course, be understood that a metallic top element such as described in connection with Fig. 6, may be applied to a paper board container such as shown and described in connection with  
75 Figs. 1 to 5 inclusive, and that the benefits of such downturned lip will, of course, be present.

Also, that in some cases, the provisions of the lip 35 may be relied upon to support the inner wall element adjacent its upper end.

In Figs. 8, 9 and 10, the invention is disclosed as applied to a rectangular paperboard container. In such a construction, the insert element  
5 embodies an auxiliary bottom element 36 formed integrally with an inner side wall element 37 which is equipped with sidewise extensions or wings 38 and 39. The bottom element 36 may  
10 also be provided with an integrally formed, depending ear 40. The insert element is, as clearly shown in Fig. 9, associated with one corner of the rectangular container so as to provide a conduit or passageway 41 of triangular cross section,  
15 and the extensions 38 and 39 of said inner wall element 37 are of such size that they fit the inside of the container and abut at their free edges against adjacent side walls of the container, as indicated at 42, 42. In this instance, the bottom  
20 side edges of the auxiliary element 36 are so formed as to fit inside of the inner faces of the extensions 38 and 39, thereby to serve as a strut for maintaining said extensions in their predetermined angular relation wherein they  
25 snugly fit inside of the container substantially as shown. It will, of course, be apparent that the auxiliary bottom element 36 is held against lateral shifting by reason of its fit in the container and the described fitting arrangement of the exten-  
30 sions 38 and 39 serves to effectively hold the inner wall element 37 in its predetermined passageway forming position. As shown in Fig. 8, the corner portion of the container top may be scored as indicated at 43, to facilitate removal of such  
35 corner portion to provide a dispensing outlet with which the passageway 41 communicates.

In the modification illustrated in Figs. 11 and 12, the arrangement is such that the upper end  
40 portion of the auxiliary or inner wall element is effectively held in place by the action of a portion of the cover element. As indicated, the cover is provided with an opening, the inner edges 44  
45 of which are inwardly disposed relative to each other and which are provided with downturned lips 45 similar to the lip 35 in the structure shown in Fig. 6. The lips 45, 45 are bent so that  
50 their outer faces are inclined upwardly and outwardly as shown and the upper end of the inner wall element designated 12b is deflected or crowded outwardly and thereby frictionally held or  
55 clamped against the wall of the container. The angular relationship of the respective lips also obviously serves to prevent sidewise shifting of the insert wall element, which may be of V-shape  
60 throughout its entire length, or have merely its upper end portion so shaped to fit the lips 45. This construction may be used with either a metal or paper insert and has the advantages, with a  
65 middle insert, of eliminating the necessity of solder or other similar fastening, and in paper construction, of reducing the amount of paper stock required in making extensions such as 19 and 20, shown in Fig. 3, for supporting the insert in its operative position.

Changes in the described structure may, of course, be made without departing from the spirit of the invention, the scope of which should be determined by reference to the following claims, the same being construed as broadly as possible  
70 consistent with the state of the art.

I claim as my invention:

1. A container having side, bottom and top walls and a dispensing outlet, and false bottom and inner wall elements spaced respectively from  
75

the bottom and wall portions of the container so as to form between said spaced parts a bottom chamber and a conduit, the latter communicating with said chamber and with said dispensing outlet, said false bottom element having an opening therein for permitting the contents of the container to run into said chamber, and a louver pressed out of said false bottom as an incident to the formation of said opening and serving to obstruct the flow of said contents through said opening into said chamber when the container is tipped to dispense the contents of said chamber.

2. A container having side, bottom and top walls, and a dispensing outlet, and an insert in the container formed of fibrous sheet material independently of the container and shaped to provide false bottom and inner wall elements spaced respectively from and cooperating with the bottom and wall portions of the container so as to form therein a bottom chamber and a conduit, the latter communicating with said chamber and with said dispensing outlet, said false bottom element having an opening therein for permitting the contents of the container to run into said chamber, and means for holding said fibrous material insert in said relation to said bottom and wall portions of the container.

3. A container having side, bottom and top walls, and a dispensing outlet, and an insert in the container formed of sheet material shaped to provide false bottom and inner wall elements spaced respectively from the bottom and wall portions of the container so as to form therein a bottom chamber and a conduit, the latter communicating with said chamber and with said dispensing outlet, said false bottom element having an opening therein for permitting the contents of the container to run into said chamber, and means for holding said insert in said relation to said bottom and wall portions of the container comprising sidewise extensions of said inner wall element, said extensions extending around the inside of the container wall and having their outer ends connected to each other so as to maintain said extensions in distended, snug-fitting relation to the container wall.

4. A container having side, bottom and top walls, and a dispensing outlet, and an insert in the container formed of sheet material independently of the container and shaped to provide false bottom and inner wall elements spaced respectively from and cooperating with the bottom and wall portions of the container so as to form therein a bottom chamber and a conduit, the latter communicating with said chamber and with said dispensing outlet, said false bottom element having an opening therein for permitting the contents of the container to run into said chamber, and means for holding said insert in said relation to said bottom and wall portions of the

container comprising sidewise extensions of said inner wall element, said extensions fitting the inside of the container so as to be thereby held in fixed relation to the container.

5. A container having side, bottom and top walls and a dispensing outlet, and an insert in the container formed of sheet material shaped to provide false bottom and inner wall elements, the inner wall element being spaced from the side wall of the container and the false bottom element being angularly disposed relative to the container bottom so as to provide a bottom chamber of gradually lessening depth in the direction extending away from said inner wall element, an opening in said false bottom for permitting the contents of the container to run into said chamber, and means extending upwardly from said false bottom and integral therewith for obstructing the flow of said contents into said chamber when the container is tipped to dispense said contents.

6. A container having side, bottom and top walls and a dispensing outlet, and an insert in the container formed of sheet material shaped to provide false bottom and inner wall elements, the inner wall element being spaced from the side wall of the container and the false bottom wall element being angularly disposed relative to the container bottom so as to provide a bottom chamber of gradually lessening depth in the direction extending away from said inner wall element, ears formed integrally with said false bottom element and depending therefrom for engaging the container bottom so as to support said false bottom, an opening in said false bottom for permitting the contents of the container to run into said chamber, and means extending upwardly from said false bottom and integral therewith for obstructing the flow of said contents into said chamber when the container is tipped to dispense said contents.

7. A dispensing container comprising top, bottom, and sides, the top having an outlet opening, a false bottom element extending over a material portion of the bottom of the container and spaced upwardly therefrom so as to provide a measuring chamber between the container bottom and said false bottom, said false bottom having an opening therein for permitting the contents of the container to flow into said measuring chamber, means adjacent a side portion of the container but spaced therefrom arranged to form a conduit communicating with said measuring chamber and said dispensing opening, and a louver extending upwardly from the false bottom and toward said conduit in overlying relation to said false bottom opening to prevent the flow of said contents into said measuring chamber when the container is tilted to dispense material.

GEORGE F. FISHER.