

Sept. 12, 1967

L. H. FRONCZEK  
PACKAGING CONTAINER

3,341,002

Filed May 22, 1963

2 Sheets-Sheet 1

Fig. 1

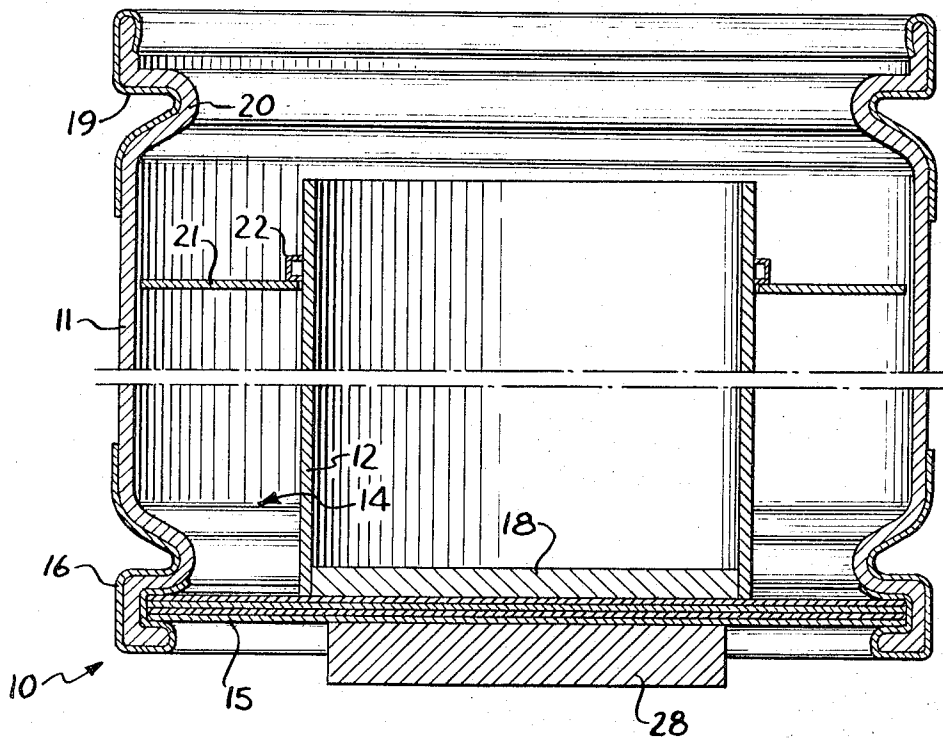

Fig. 2

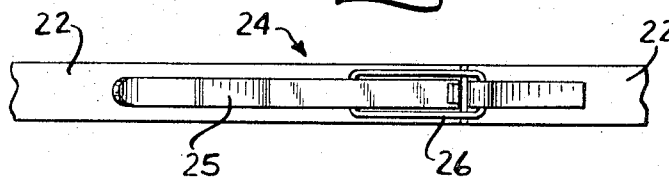
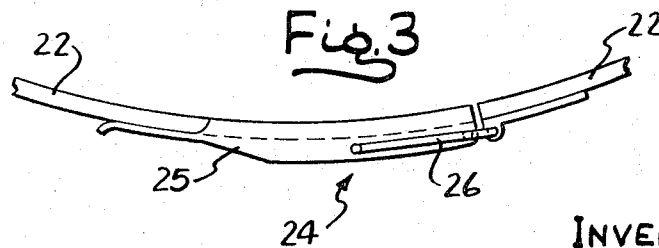

Fig. 3



INVENTOR  
LAURENS HEINRICH FRONCZEK

by: *Wolfe, Hubbard, Voit & Osann*  
ATTYS.

Sept. 12, 1967

L. H. FRONCZEK  
PACKAGING CONTAINER

3,341,002

Filed May 22, 1963

2 Sheets-Sheet 2

Fig. 4

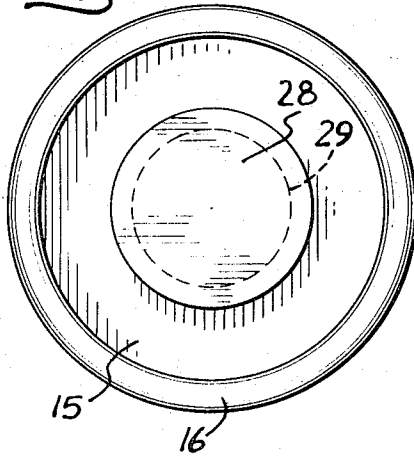

Fig. 5

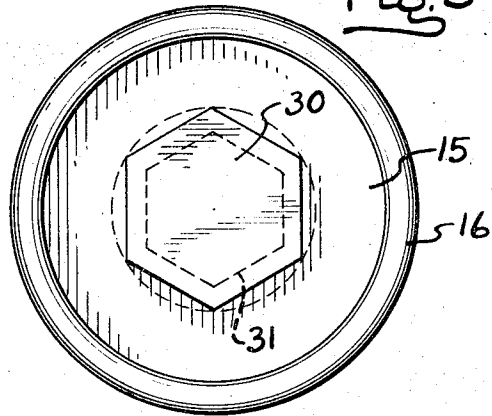

Fig. 6

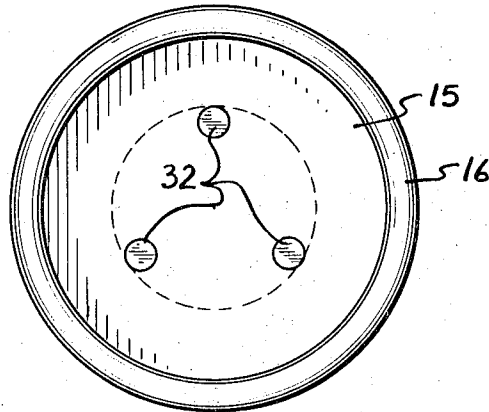
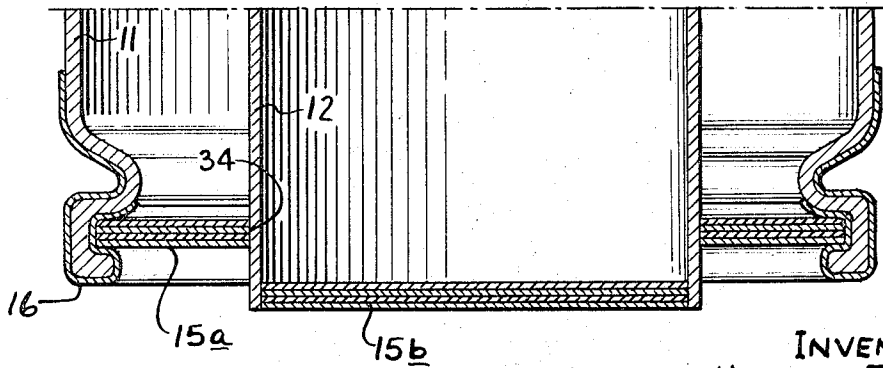

Fig. 7



INVENTOR  
LAURENS HEINRICH FRONCZEK

by: Wolfe, Hubbard, Voit & Osann  
ATTYS.

1

3,341,002

**PACKAGING CONTAINER**

Laurens Heinrich Fronczek, Autheuil-sur-Eure, France, assignor, by mesne assignments, to Inland Steel Company, Chicago, Ill., a corporation of Delaware  
 Filed May 22, 1963, Ser. No. 282,367  
 15 Claims. (Cl. 206—52)

The present invention relates generally to containers and, more particularly, to an improved container construction for packaging wire, ribbon, strip or strap material, and similar elongate cord-like products. In its principal aspects, the invention is concerned with improved closure and centering assemblies suitable for use with packaging containers of the type intended to store the packaged product in coil form, and wherein the container serves as a "paying-off device" or reel which permits the product to be drawn directly from the container to processing equipment or similar utilization devices.

For a number of years there has been a persistent and increasing demand for packaging containers suitable for use in storing, transporting and "paying out" wire or similar cord-like strip or strap products. Conventional wire packaging containers have employed an outer shell, a substantially coaxial inner core, and a bottom member secured to one end of both the shell and the core and closing at least the annular space therebetween at one end of the container. The packaged product is coiled within the annular space defined by the core and the shell.

A major problem encountered with such containers has been that of providing effective means for insuring that the coils of the packaged product remain tightly confined, particularly during transport. In an effort to solve this problem, it has heretofore been a general practice to position an annular confining disk on top of the coiled product, the disk being retained in place by a rubber cushion which is clamped between the disk and the cover of the container. However, such container constructions for tightly confining the coiled product have a number of disadvantages. For example, the axial heights of the coiled product may vary within rather wide limits, thus requiring the packager to maintain its stock, and properly utilize, rubber cushions having different thicknesses. Absent the proper selection of, and use of, a cushion having the correct thickness, the coiled product will, in all probability, be packed either too tightly or too loosely, thereby causing entanglement of the coils and interference with decoiling of the packaged product. Moreover, the "dead weight" of the container is increased by such spacers during transport of a full container to a point of use and an empty container from a point of use.

It is a general aim of the present invention to provide an improved container for packaging coiled products which overcomes all of the foregoing disadvantages and which permits packaging of such coiled products with the requisite degree of tightness under a wide range of variable conditions, yet which is characterized by its simplicity and reliability in operation. While not so limited in its application, the invention will find especially advantageous use with containers of the type commonly referred to as "wire packaging containers."

A more specific object of the invention is to provide an improved closure construction for a coiled product container characterized by its effectiveness in maintaining the coils tightly confined within the container, yet which

2

is versatile and will provide a positive closure at any desired axial position relative to the container, thus permitting use of the container for shipping a wide range of different thickness products as well as any desired amount of a given product.

In this connection, it is a related object of the invention to provide an improved closure assembly for coiled product containers which, because of its versatility in application, eliminates the need for packagers and users to maintain stocks of compensating cushioning spacers.

Yet another object of the invention is to provide a compact closure assembly for coiled product containers which is light in weight, thus reducing "dead weight" during shipment of both empty and full containers.

In another of its important aspects, it is an object of the invention to provide an improved coiled product packaging container which readily permits of use as a reel or "paying-off device." In this connection, the invention not only provides for maintaining the coils in their proper wound relationship during transport, thus facilitating decoiling thereof, but, it also facilitates mounting of the container on both the decoiling or utilization equipment and the coiling or packaging equipment.

A further object of the invention is the provision of a novel coiled product packaging container which facilitates handling of both the product during uncoiling operations and the container during transport.

Yet another object of the invention is the provision of a coiled product container which permits of economy in manufacture, and wherein the closure plate therefore may be readily affixed to and removed from the container.

Other objects and advantages of the invention will become apparent as the following description proceeds, taken in conjunction with the accompanying drawings, in which:

FIGURE 1 is a fragmentary vertical, cross-sectional view of a packaging container embodying the features of the present invention;

FIG. 2 is an enlarged fragmentary side elevation of an exemplary closure ring used with the container shown in FIG. 1;

FIG. 3 is a plan view illustrating details of the closure ring shown in FIG. 2;

FIG. 4 is a bottom view of the container shown in FIG. 1, here depicting an exemplary container centering assembly;

FIGS. 5 and 6 are views similar to FIG. 4 illustrating particularly modified forms of container centering assemblies; and

FIG. 7 is a fragmentary vertical cross-sectional view similar to FIG. 1 of a portion of a container, here illustrating yet another modification also embodying the features of the present invention.

While the invention is susceptible of various modifications and alternative forms, specific embodiments thereof have been shown by way of example in the drawings and will herein be described in detail. It should be understood, however, that it is not intended to limit the invention to the particular forms disclosed, but, on the contrary, the intention is to cover all modifications, equivalents and alternatives falling within the spirit and scope of the invention as expressed in the appended claims.

Referring now to the drawings, there is illustrated in FIG. 1 a packaging container 10 having a generally cylindrical outer shell 11 and a coaxial cylindrical core

12, the latter having a considerably smaller diameter and defining with the shell an annular space 14 suitable for receiving and storing coils of the product to be packaged, for example, coils of wire (not shown). As the ensuing description proceeds, those skilled in the art will appreciate that the container 10 can be made of a wide variety of materials, both metallic and non-metallic. Merely by way of example, a typical but non-exhaustive list of such materials would include steel, paperboard, fiber, or other natural or synthetic materials. However, the invention is here illustrated in connection with a container 10 having an outer shell 11 made of paperboard, it being understood that other materials may also be used if desired.

In the illustrative container construction, the cylindrical shell 11 and core 12 (which could, for example, have prismatic cross-sectional shapes rather than cylindrical) are rigidly secured to a bottom member 15 which serves to close at least the annular space 14 at the bottom of the container 10. To this end, the lower edge of the shell is, in a conventional manner, folded into channel shape so as to grip the marginal edge of the bottom member 15. A bent metallic reinforcing ring 16 may be applied to the lower edge of the shell 11 to minimize damage thereto during handling—such rings being particularly desirable when the shell is made of paperboard or similar fibrous material. The core 12 is rigidly secured adjacent its lower end to a cylindrical disk 18, the latter being centered on and secured to the end member 15. The upper end of the exemplary container 10 is shaped similar to the lower end, having a bent metallic reinforcing ring 19 surrounding an inwardly projecting circumferential rib 20 formed in the upper edge of the shell 11.

The particular fastening means employed for securing the above container components together will vary, of course, dependent upon the materials from which the container is made. For example, if the container is made of paperboard or similar materials, the parts may be secured together by nails, stitching, gluing, or the like. On the other hand, where the container is made of metal, the parts may be welded together, or secured by means of rivets or threaded fasteners.

In accordance with one of the important aspects of the present invention, provision is made for tightly confining the turns of the coiled product within the annular space 14 defined by the shell 11, core 12 and bottom member 15, thus insuring that, irrespective of the axial height of the coiled stock, the individual coils or turns will maintain their proper wound relationship relative to all of the remaining coils. In the illustrative form of the invention, this is accomplished by slidably mounting an annular confining disk, or closure disk 21, on the core 12 in overlying relation to the turns of the coiled product (not shown) and locking the disk 21 in a fixed axial position relative to the container, thus insuring that the disk is prevented from moving axially away from the bottom member 15.

In carrying out this aspect of the invention, the exemplary packaging container is provided with a closing ring 22 which is axially slidable relative to the container 10 and which includes means for positively clamping the ring to one of the components of the container, for example, to the core 12. To this end, the closing ring 22 takes the form of a split ring having clamping means, generally indicated at 24 (FIG. 2 and 3), for securing the ring to the outer surface of the core 12. When clamped in a fixed axial position, the ring 22 overlies at least a portion of the closure disk 21, thus serving to inhibit outward (upward in FIG. 1) axial movement of the disk. As here shown, the clamping means 24 may simply take the form of an "over-center toggle clamp" having an actuating lever 25 which is pivotally connected to one end of the split ring 22, and a link 26 which pivotally connects the opposite end of the ring 22 to the lever 25 intermediate the ends of the latter.

The arrangement is such that when the lever 25 is swung inwardly in the plane of the ring 22 into engagement with the outer face of the ring, the latter is contracted by the toggle action of the clamping lever 25 and link 26, thereby clamping the ring 22 against the core 12. On the other hand, when the lever 25 is swung outwardly, the ring 22 is expanded thus freeing the ring for sliding movement relative to the core 12. Of course, the ring 22 may be rigidly secured to the closure disk 21 by any suitable means (not shown), so as to insure that the two move as a unit, thereby facilitating their removal from the container 10, and so that the disk 21 is positively locked to the container 10 when the clamp 24 is operatively engaged. Alternatively, the disk 21 and ring 22 may be completely separate components.

In operation, after the wire or similar product is coiled in the annular space 14 within the container 10, the annular closure disk 21 is lowered onto the uppermost turns or coils (not shown) and locked in position by operation of the "over-center toggle clamp" 24. This serves to tightly confine the coiled wire within the annular space 14 and prevents different turns of the wire from becoming entangled.

In accordance with another of the important aspects of the present invention, provision is made for centering the container 10 relative to both processing or unreeling equipment and packaging or reeling equipment, thus facilitating decoiling and coiling of the product within the container. To this end, the illustrative form of the invention shown in FIGS. 1 and 4 includes a circular centering disk 28 which is coaxial with the core 12 and is rigidly secured to the lower surface of the bottom member 15 in such a manner that the disk 28 projects downwardly or outwardly beyond the plane defined by the lower edge of the shell 11. Alternatively, the centering disk 28 may simply take the form of a centering ring as indicated by the broken lines 29 shown in FIG. 4. Both of the foregoing constructions not only serve to center the container 10 relative to the coiling or decoiling equipment, but moreover, they also permit the forks of conventional fork lift trucks to be readily inserted under the container on either side of the centering disk 28 or ring 29, thus simplifying handling of the container.

A slightly modified centering assembly is shown in FIG. 5. As here illustrated, the centering means may simply take the form of a polygonal disk 30, or polygonal ring represented by the broken lines 31, which are again fixedly secured to the bottom member 15. In these types of constructions, it is only necessary that at least three corners of the polygonal member be located upon a circle which is coaxial with the core 12, while no other corner of the polygon extends outside of the circle.

As best shown in FIG. 6, the centering assembly may also take the form of a plurality of projections or studs 32 which are disposed on the bottom surface of the member 15 in a circular pattern coaxial with the axis of the core 12. Three such studs 32 are shown in FIG. 6, although those skilled in the art will appreciate that four or more might be used in a circular pattern.

Referring to FIG. 7, it will be observed that the bottom member is here formed as an annular ring 15a defining an opening 34 dimensioned to snugly receive the lower end of the core 12—the core here passing through the opening 34 and projecting beneath the plane of the lower edge of the shell 11. The core 12 is secured to the annular ring 15a in any suitable manner, for example, by nailing, stitching, gluing, welding, riveting, or by the use of connecting rings (not shown) having an L-shaped cross section. In this form of the invention, the outwardly or downwardly projecting portion of the core serves as the centering means. If desired, the lower end of the core 12 may be closed by means of the disk 15b obtained when forming the opening 34 in the bottom member 15a, thus providing a considerable saving in material.

Of course, it will be apparent that the inner surfaces of the ring 29 (FIG. 4), ring 31 (FIG. 5), or studs 24 (FIG. 6), all serve to define a recessed portion on the container bottom which can be used for centering purposes. Such recessed portions could also be formed directly in the bottom 15 of the container.

I claim as my invention:

1. A container for packaging coiled products comprising, in combination, an outer shell member, an inner core member substantially coaxial with said shell member and defining an annular storage space therebetween, a container bottom rigidly secured to both of said members adjacent their lower edges and closing at least said annular storage space at its lower end, an annular closure disk positioned within said storage space and slidably mounted about said core member for axial sliding movement relative to said members, said disk adapted to abut the uppermost turns of the coiled contents of said container, and stop means associated with said closure disk and at least one of said members, said stop means defining an axially adjustable fixed stop for limiting axial movement of said disk in a direction away from said container bottom so as to maintain said disk in abutment with the coiled contents in said container so that the turns thereof are maintained in their proper wound relationship on said core member.

2. A container for packaging coiled products comprising, in combination, an outer shell members, an inner core member substantially coaxial with said shell member and defining an annular storage space therebetween, a container bottom rigidly secured to both of said members adjacent their lower edges and closing at least said annular storage space at its lower end, an annular closure disk positioned within said storage space and slidably mounted about said core member for axial sliding movement relative to said members, said disk adapted to abut the uppermost turns of the coiled contents of said container, an annular closure ring surrounding said core member and slideably mounted thereon, said ring overlying at least a portion of said disk, and means for urging said ring into positive locked engagement with one of said members at any selected axial distance from said bottom corresponding to the axial height of the contents of said container so that axial outward movement of said disk is inhibited.

3. A container for packaging coiled products comprising, in combination, an outer shell member, an inner core member substantially coaxial with said shell member and defining an annular storage space therebetween, a container bottom rigidly secured to both of said members adjacent their lower edges and closing at least said annular storage space at its lower end, an annular closure disk positioned within said storage space and slidably mounted on said core member for axial movement relative to said members, said disk adapted to abut the uppermost turns of the coiled contents of said container, an annular closure ring surrounding said core member and slidably mounted thereon, said ring overlying at least the inner marginal edge of said disk, and means for locking said ring to said core member at any selected axial position corresponding to the axial height of the contents of said container so that said disk is inhibited from movement in a direction away from the coiled contents of said container.

4. A container for packaging coiled products comprising, in combination, an outer shell member, an inner core member substantially coaxial with said shell member and defining an annular storage space therebetween, a container bottom rigidly secured to both of said members adjacent their lower edges and closing at least said annular storage space at its lower end, a closure assembly positioned within said storage space and slidably mounted about said core member for axial sliding movement relative to said members, said assembly including means adapted to abut the uppermost turns of the coiled contents

of said container, and means for positively locking said assembly to one of said members at any selected axial distance from said bottom corresponding to the axial height of the coiled contents in said container so that the turns thereof are maintained in their proper wound relationship on said core member.

5. A container for packaging coiled products comprising, in combination, an outer shell member, an inner core member substantially coaxial with said shell member and defining an annular storage space therebetween, a container bottom rigidly secured to both of said members adjacent their lower edges and closing said annular storage space at its lower end, an annular closure assembly positioned within said storage spaced and slidably mounted about said core member for axial sliding movement relative to said members, said assembly including means shaped to conform to the cross sectional configuration of said storage space and adapted to abut the uppermost turns of the coiled contents of said container, stop means associated with said closure assembly and at least one of said members, said stop means defining an axially adjustable fixed stop for limiting axial movement of said closure assembly in a direction away from said container bottom so as to maintain said assembly in abutment with the coiled contents in said container so that the turns thereof are maintained in their proper wound relationship on said core member, and centering means for said container disposed in a circular pattern coaxial with said core member, said centering means projecting outwardly from said container bottom beyond the lower edge of said shell member.

6. A container as set forth in claim 5 further characterized in that the lower extremity of said core member passes downwardly through an opening formed in said container bottom with the downwardly projecting portion of said core member defining said centering means.

7. A container as set forth in claim 5 further characterized in that said centering means includes a circular disk having its center lying on the axis of said core member.

8. A container as set forth in claim 5 further characterized in that said centering means comprises an annular ring having its center lying on the axis of said core member.

9. A container as set forth in claim 5 further characterized in that said centering means comprises a polygonal disk having its center lying on the axis of said core member, said disk having at least three corners thereof defining a circle concentric with said axis and with all other corners of said disk lying within the circle defined by said three corners.

10. A container as set forth in claim 5 further characterized in that said centering means comprises a polygonal ring having its center lying on the axis of said core member, said ring having at least three corners thereof defining a circle concentric with said axis and with all other corners of said ring lying within the circle defined by said three corners.

11. A container as set forth in claim 5 further characterized in that said centering means comprises a plurality of projections formed on said container bottom in a circular pattern with the center of the circle defined by said projections lying on the axis of said core member.

12. A container as set forth in claim 5 further characterized in that said centering means is defined by at least one recess formed in said container bottom.

13. A container for packaging coiled products comprising, in combination, an outer shell member, an inner core member substantially coaxial with said shell member and defining an annular storage space therebetween, a container bottom rigidly secured to both of said members adjacent their lower edges and closing at least said annular storage space at its lower end, an annular closure disk positioned within said storage space and slidably mounted on said core member for axial movement rela-

tive to said members, said disk adapted to abut the uppermost turns of the coiled contents of said container, an annular closure ring surrounding said core member and slidably mounted thereon, said ring overlying at least the inner marginal edge of said disk, means for locking said ring to said core member at any selected axial position corresponding to the axial height of the contents of said container so that said disk is inhibited from movement in a direction away from the coiled contents of said container, said closure ring being a split ring and said locking means comprise an over-center toggle clamp operatively connected to the ends of said split ring for contacting said ring into positive locked engagement with said core member at any selected axial position relative thereto.

14. A container for packaging coiled products comprising, in combination, an outer shell member, an inner core member substantially coaxial with said shell member and defining an annular storage space therebetween, a container bottom rigidly secured to both of said members adjacent their lower edges and closing at least said annular storage space at its lower end, a closure assembly positioned within said storage space and slideably mounted about said core member for axial sliding movement relative to said members, said assembly including means adapted to abut the uppermost turns of the coiled contents of said container, means for positively locking said assembly to one of said members at any selected axial distance from said bottom corresponding to the axial height of the coiled contents in said container so that the turns thereof are maintained in their proper wound relationship on said core member, said closure assembly including an annular closure disk corresponding in shape to the cross section of said annular storage space, a ring integral with at least one edge of said disk and normally spaced from the adjacent one of said members, and means for urging said ring radially into positive locked engagement with the adjacent one of said members.

15. A container for packaging coiled products comprising, in combination, an outer shell member, an inner core member substantially coaxial with said shell member and defining an annular storage space therebetween, a con-

tainer bottom rigidly secured to both of said members adjacent their lower edges and closing at least said annular storage space at its lower end, a closure assembly positioned within said storage space and slideably mounted about said core member for axial sliding movement relative to said members, said assembly including means adapted to abut the uppermost turns of the coiled contents of said container, means for positively locking said assembly to one of said members at any selected axial distance from said bottom corresponding to the axial height of the coiled contents in said container so that the turns thereof are maintained in their proper wound relationship on said core member, said closure assembly including an annular closure disk corresponding in shape to the cross section of said annular storage space, a ring integral at least one edge of said disk and normally spaced from the adjacent one of said members, means for urging said ring radially into positive locked engagement with the adjacent one of said members, said ring being a split ring and the means for urging said ring laterally includes an over-center toggle clamp for contracting said ring into positive engagement with said core member.

## References Cited

## UNITED STATES PATENTS

2,752,108	6/1956	Richardson	242—128
2,858,088	10/1958	Bookout	242—128
2,864,565	12/1958	Whearley	242—128
2,869,719	1/1959	Hubbard	242—129
2,889,921	6/1959	Hubbard	206—52
2,963,240	12/1960	Jackson	242—128
3,041,006	6/1962	Eckert	242—128
3,136,496	6/1964	McMartin	242—128
3,156,354	11/1964	Laymon	206—53

## FOREIGN PATENTS

748,288	4/1956	Great Britain.
764,975	1/1957	Great Britain.

LOUIS G. MANCENE, *Primary Examiner.*