



(51) International Patent Classification:

B23D 35/00 (2006.01) B26F 1/14 (2006.01)
B23P 11/00 (2006.01) B26F 1/38 (2006.01)
B21D 28/34 (2006.01)

(21) International Application Number:

PCT/US2022/039026

(22) International Filing Date:

01 August 2022 (01.08.2022)

(25) Filing Language:

English

(26) Publication Language:

English

(30) Priority Data:

63/228,339 02 August 2021 (02.08.2021) US
17865799 15 July 2022 (15.07.2022) US

(71) Applicant: EMERSON PROFESSIONAL TOOLS,

LLC [US/US]; 400 Clark Street, Elyria, OH 44035 (US).

(72) Inventors: PIPER, Arthur, A.; 4778 Staffordshire Court,

Loves Park, IL 61111 (US). BENTLEY, Robert, Bruce;
12808 Caribou Court, Columbia Station, OH 44028 (US).
TROY, Andrew; 540 W. Webster Avenue, Chicago, IL
60614 (US). MCMANUS, Ryan; 706 St. Vincents Avenue,
Peru, IL 61354 (US).

(74) Agent: PALOMAR, Linda, L.; Klintworth & Rozenblat

IP LLP, 2045 W Grand Ave Ste B, PMB 84396, Chicago,
IL 60612-1577 (US).

(81) Designated States (unless otherwise indicated, for every

kind of national protection available): AE, AG, AL, AM,
AO, AT, AU, AZ, BA, BB, BG, BH, BN, BR, BW, BY, BZ,
CA, CH, CL, CN, CO, CR, CU, CV, CZ, DE, DJ, DK, DM,
DO, DZ, EC, EE, EG, ES, FI, GB, GD, GE, GH, GM, GT,
HN, HR, HU, ID, IL, IN, IQ, IR, IS, IT, JM, JO, JP, KE,
KG, KH, KN, KP, KR, KW, KZ, LA, LC, LK, LR, LS, LU,
LY, MA, MD, ME, MG, MK, MN, MW, MX, MY, MZ, NA,
NG, NI, NO, NZ, OM, PA, PE, PG, PH, PL, PT, QA, RO,
RS, RU, RW, SA, SC, SD, SE, SG, SK, SL, ST, SV, SY, TH,

(54) Title: PUNCH AND DRAW STUD HAVING MULTI-START THREADS, AND METHOD OF ENGAGING SAME

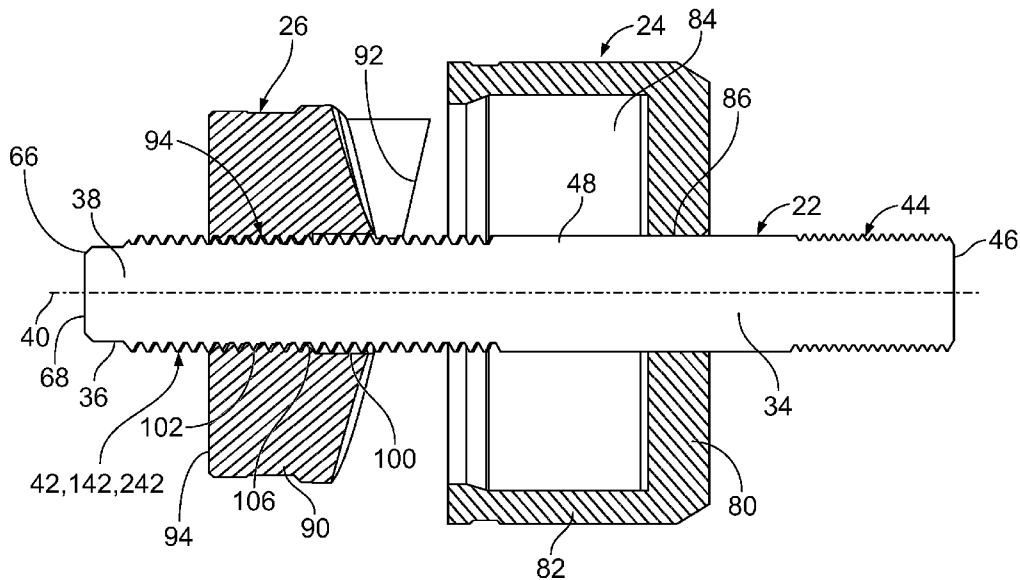
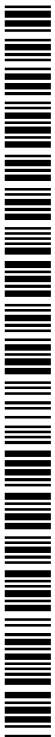

FIG. 16

(57) Abstract: A punch according to some embodiments of the disclosure includes a body having a punching edge and a wall forming a passageway therethrough, the wall having a multi-start thread formed thereon, and a draw stud according to some embodiments of the disclosure includes an elongated cylinder having a multi-start thread thereon which is configured to be coupled to the multi-start thread of the punch. The number of starts provided on the punch corresponds to the number of starts provided on the draw stud. The multi-start thread on the punch is engaged with the multi-start thread on the draw stud in use. A method using same to punch a hole in sheet metal is also provided.



TJ, TM, TN, TR, TT, TZ, UA, UG, US, UZ, VC, VN, WS,
ZA, ZM, ZW.

(84) Designated States (*unless otherwise indicated, for every kind of regional protection available*): ARIPO (BW, GH, GM, KE, LR, LS, MW, MZ, NA, RW, SD, SL, ST, SZ, TZ, UG, ZM, ZW), Eurasian (AM, AZ, BY, KG, KZ, RU, TJ, TM), European (AL, AT, BE, BG, CH, CY, CZ, DE, DK, EE, ES, FI, FR, GB, GR, HR, HU, IE, IS, IT, LT, LU, LV, MC, MK, MT, NL, NO, PL, PT, RO, RS, SE, SI, SK, SM, TR), OAPI (BF, BJ, CF, CG, CI, CM, GA, GN, GQ, GW, KM, ML, MR, NE, SN, TD, TG).

Published:

— *with international search report (Art. 21(3))*

PUNCH AND DRAW STUD HAVING MULTI-START THREADS,
AND METHOD OF ENGAGING SAME

CROSS-REFERENCE TO RELATED APPLICATION

[0001] This application claims priority to United States application Serial No. 17/865,799, filed July 15, 2022 and United States provisional application Serial No. 63/228,339, filed on August 2, 2021, the contents of which are incorporated herein in its entirety.

FIELD OF THE DISCLOSURE

[0002] The present disclosure relates to a draw stud having a multi-start thread for use with a punch having a multi-start thread, and methods of engaging same.

BACKGROUND

[0003] In the commercial electrical contractor market, many jobs start with installing conduit runs for connecting wires between electrical boxes. During installation, holes must be formed in electrical boxes and various other sheet metal components to feed the wire and conduit therethrough. A punch system is commonly used in this operation.

[0004] Some prior art punch systems include a draw stud, a die, a punch and a nut. The punch is seated on a first end of the draw stud and secured thereto by threading the nut onto the first end of the draw stud. The die is seated on a second end of the draw stud.

[0005] The operator drills a pilot hole approximately in the center of the area where the final hole needs to be located. The draw stud, which has been attached to a driver, has the die slid over its free end until the die abuts the driver. The draw stud is then inserted with its free end first through the pilot hole until the die is seated against one side of a sheet metal. The knockout punch, which has a central hole with internal threads, is seated onto the free end of the draw stud until the knockout punch impinges onto the side of the sheet metal opposite the side on which the die is located. The nut is then attached to the draw stud to secure the punch to the draw stud. As a result, the sheet metal is snugly captured on both sides by the die and punch. Finally, the driver is actuated such that the draw stud and the knockout punch are drawn toward the driver,

supplying sufficient force to the knockout punch to puncture and cut the sheet metal and produce the final hole.

[0006] The driver is operated manually or hydraulically. Overall, this punch system works well, however, the most time consuming task is attaching the knockout punch onto the draw stud, which can take as long as thirty to sixty seconds to accomplish depending on the length of the draw stud. This can be frustrating and inefficient for the operator, especially when a great number of holes need to be punched.

SUMMARY

[0007] A punch according to some embodiments of the disclosure includes a body having a punching edge and a wall forming a passageway therethrough, the wall having a multi-start thread formed thereon, and a draw stud according to some embodiments of the disclosure includes an elongated cylinder having a multi-start thread thereon which is configured to be coupled to the multi-start thread of the punch. The number of starts provided on the punch corresponds to the number of starts provided on the draw stud. The multi-start thread on the punch is engaged with the multi-start thread on the draw stud in use.

[0008] A method of punching a hole includes forming a pilot hole in sheet metal, attaching a draw stud to a driver, sliding a die over a free end of the draw stud until the die is proximate to the driver, inserting the free end of the draw stud through the pilot hole until the die is seated against one side of the sheet metal and engaged with the driver, engaging a multi-start thread of a knockout punch with a multi-start thread of the draw stud, wherein a number of starts provided on the punch corresponds to a number of starts provided on the draw stud, rotating the knockout punch in a first direction to thread the knockout punch onto the free end of the draw stud until the knockout punch impinges onto a side of the sheet metal opposite the side on which the die is located, and actuating the driver to draw the draw stud and the knockout punch toward the die and to puncture and cut the sheet metal and produce a final hole.

[0009] This Summary is provided merely for purposes of summarizing some example

embodiments so as to provide a basic understanding of some aspects of the disclosure. Accordingly, it will be appreciated that the above described example embodiments are merely examples and should not be construed to narrow the scope or spirit of the disclosure in any way. Other embodiments, aspects, and advantages of various disclosed embodiments will become apparent from the following detailed description taken in conjunction with the accompanying drawings which illustrate, by way of example, the principles of the described embodiments.

BRIEF DESCRIPTION OF THE DRAWINGS

[0010] The organization and manner of the structure and operation of the disclosed embodiments, together with further objects and advantages thereof, may best be understood by reference to the following description, taken in connection with the accompanying drawings, which are not necessarily drawn to scale, wherein like reference numerals identify like elements in which:

[0011] FIG. 1 depicts a perspective view of a punch system shown mounted to sheet metal;

[0012] FIG. 2 depicts an exploded perspective view of the punch system, and a bearing of a driver;

[0013] FIG. 3 depicts a perspective view of a punch system shown mounted to sheet metal;

[0014] FIG. 4 depicts an exploded perspective view of the punch system of FIG. 3;

[0015] FIG. 5 depicts a perspective view of a portion of a draw stud of the punch system showing a four-start thread;

[0016] FIG. 6 depicts a side elevation view of a portion of the draw stud of FIG. 5;

[0017] FIG. 7 depicts an end elevation view of the draw stud of FIG. 5;

[0018] FIG. 8 depicts a perspective view of a portion of a draw stud of the punch system showing a three-start thread;

[0019] FIG. 9 depicts a side elevation view of a portion of the draw stud of FIG. 8;

[0020] FIG. 10 depicts an end elevation view of the draw stud of FIG. 8;

[0021] FIG. 11 depicts a perspective view of a portion of a draw stud of the punch system

showing a two-start thread;

[0022] FIG. 12 depicts a side elevation view of a portion of the draw stud of FIG. 11;

[0023] FIG. 13 depicts an end elevation view of the draw stud of FIG. 11;

[0024] FIG. 14 depicts a side elevation view of a portion of the draw stud of FIG. 9 according to another embodiment;

[0025] FIG. 15 depicts a cross-sectional view of a punch of the punch system;

[0026] FIG. 16 depicts a cross-sectional view of the punch system; and

[0027] FIGS. 17-22 depict manual torque graphs.

DESCRIPTION

[0028] While the disclosure may be susceptible to embodiment in different forms, there is shown in the drawings, and herein will be described in detail, a specific embodiment with the understanding that the present disclosure is to be considered an exemplification of the principles of the disclosure, and is not intended to limit the disclosure to that as illustrated and described herein. Therefore, unless otherwise noted, features disclosed herein may be combined together to form additional combinations that were not otherwise shown for purposes of brevity. It will be further appreciated that in some embodiments, one or more elements illustrated by way of example in a drawing(s) may be eliminated and/or substituted with alternative elements within the scope of the disclosure.

[0029] As shown in FIGS. 1 and 3, a punch system 20 includes a draw stud 22, a die 24 mounted on the draw stud 22, and a knockout punch 26 mounted on the draw stud 22. In use, an operator drills a pilot hole 28 approximately in the center of an area in sheet metal 30 where the final hole needs to be located. The draw stud 22, which has been attached to a driver 32, 32a, has the die 24 slid over its free end until the die 24 is proximate to or abuts the driver 32, 32a. The draw stud 22 is then inserted with its free end first through the pilot hole 28 until the die 24 is seated against one side of the sheet metal 30. The knockout punch 26 is rotated in a first direction to thread the knockout punch 26 onto the free end of the draw stud 22 until the knockout punch 26 impinges

onto the side of the sheet metal 30 opposite the side on which the die 24 is located. As a result, the sheet metal 30 is snugly captured on both sides by the die 24 and punch 26. Finally, the driver 32, 32a is actuated such that the draw stud 22 and the knockout punch 26 are drawn toward the die 24 and the driver 32, 32a, supplying sufficient force to the knockout punch 26 to puncture and cut the sheet metal 30 and produce the final hole. The punch system 20 of the present disclosure provides an efficient method to fasten the punch 26 onto the draw stud 22. When the draw stud 22 and the punch 26 are threaded together, the draw stud 22 and the punch 26 self-lock, which prevents the reverse rotation of the punch 26 (in a second direction which is opposite to the first direction) when the draw stud 22 and the punch 26 are drawn toward the driver 32, 32a. Because of the configuration of the attachment between the draw stud 22 and the punch 26, the use of a nut, as was done in the prior art, has been eliminated. In addition, the punch 26 is tightened onto the draw stud 22 in one motion. The reduction of components by the elimination of the prior art nut, and the action required to tighten the punch system 20 enhances the efficiency over the prior art.

[0030] The draw stud 22 has an elongated cylindrical body 34 and has an unthreaded cylindrical dog point 36 integrally formed therewith and extending longitudinally from a front end 38 thereof. The body 34 and the dog point 36 extending therefrom define a longitudinal centerline axis 40. The body 34 has a multi-start external thread 42, 142, 242 formed thereon which extends distally from the dog point 36, and a driver attachment 44, 44a extending proximally from a second end 46 thereof. The multi-start external thread 42, 142, 242 is configured to be coupled to the punch 26. The driver attachment 44, 44a is configured to be coupled to the driver 32, 32a. The draw stud 22 has a central section 48 extending between the multi-start external thread 42, 142, 242 and the driver attachment 44, 44a.

[0031] As shown in the embodiment of FIGS. 5-7, the multi-start external thread 42 on the draw stud 22 has four intertwined coarse helical threads 50, 52, 54, 56, with the start of each thread 50, 52, 54, 56 being 90° apart from each other as best shown in FIG. 7. As shown in FIG. 6, each thread 50, 52, 54, 56 has thread angle α defined by a 60° included thread form. The threads 50,

52, 54, 56 define the same major diameter 58 along the portion of the draw stud 22 on which the threads 50, 52, 54, 56 are provided, and the same minor diameter 60 along the portion of the draw stud 22 on which the threads 50, 52, 54, 56 are provided. The major diameter 58 of the four intertwined coarse helical threads 50, 52, 54, 56, may be the same as the outer diameter of the central section 48, or may be less than the outer diameter of the central section 48. Each thread 50, 52, 54, 56 has a cone-shaped lead-in surface 62 which extends at an angle β of $45^\circ \pm 5^\circ$ relative to the centerline axis 40 when viewed in cross-section. The cone-shape of the lead-in surface 62 is interrupted by the starts of the threads 50, 52, 54, 56.

[0032] As shown in the embodiment of FIGS. 8-10, the multi-start external thread 142 on the draw stud 22 has three intertwined coarse helical threads 150, 152, 154, with the start of each thread 150, 152, 154 being 120° apart from each other as best shown in FIG. 10. As shown in FIG. 9, each thread 150, 152, 154 has thread angle α defined by a 60° included thread form. The threads 150, 152, 154 define the same major diameter 158 along the portion of the draw stud 22 on which the threads 150, 152, 154 are provided, and the same minor diameter 160 along the portion of the draw stud 22 on which the threads 150, 152, 154 are provided. The major diameter 158 may be the same as the outer diameter of the central section 48, or may be less than the outer diameter of the central section 48. Each thread 150, 152, 154 has a cone-shaped lead-in surface 162 which extends at an angle β of $45^\circ \pm 5^\circ$ relative to the centerline axis 40 when viewed in cross-section. The cone-shape of the lead-in surface 162 is interrupted by the starts of the threads 150, 152, 154.

[0033] As shown in the embodiment of FIGS. 11-13, the multi-start external thread 242 on the draw stud 22 has two intertwined coarse helical threads 250, 252, with the start of each thread 250, 252 being 180° apart from each other as best shown in FIG. 13. As shown in FIG. 12, each thread 250, 252 has a thread angle α defined by a 60° included thread form. The threads 250, 252 define the same major diameter 258 along the portion of the draw stud 22 on which the threads 250, 252 are provided, and the same minor diameter 260 along the portion of the draw stud 22 on which the

threads 250, 252 are provided. The major diameter 258 of the two intertwined coarse helical threads 250, 252, may be the same as the outer diameter of the central section 48, or may be less than the outer diameter of the central section 48. Each thread 250, 252 has a cone-shaped lead-in surface 262 which extends at an angle β of $45^\circ \pm 5^\circ$ relative to the centerline axis 40 when viewed in cross-section. The cone-shape of the lead-in surface 262 is interrupted by the starts of the threads 250, 252.

[0034] In an embodiment, the multi-start external thread on the draw stud 22 has five intertwined coarse helical threads (not shown), with the start of each thread being 72° apart from each other.

[0035] The multi-start thread 42, 142, 242 limits the number of rotations required to secure the punch 26 into position on the draw stud 22 by increasing the linear distance traveled over a single rotation. A single start thread has a much smaller lead than a four-start thread per revolution, and a draw stud having a single start punch would require the punch to rotate at least four times more than the draw stud 22 having four starts as shown in FIGS. 5-7, to move the same linear distance. A single start thread has a much smaller lead than a three-start thread per revolution, and a draw stud having a single start punch would require the punch to rotate at least three times more than the draw stud 22 having three starts, as shown in FIGS. 8-10, to move the same linear distance. Likewise, a single start thread has a much smaller lead than a two-start thread per revolution, and a draw stud having a single start punch would require the punch to rotate at least two times more than the draw stud 22 having two starts, as shown in FIGS. 11-13, to move the same linear distance.

[0036] In some embodiments, the central section 48 is unthreaded section (as shown) and has an outer diameter that is the same as, or larger than, the major diameter 58, 158, 258 of the multi-start external thread 42, 142, 242. In some embodiments, the central section 48 is threaded (not shown) and has an outer diameter defined by a major diameter of the threads that is the same as the major diameter 58, 158, 258 of the multi-start external thread 42, 142, 242.

[0037] In some embodiments, the dog point 36 defines an outer diameter 64 which is less than

the minor diameter 60, 160, 260. In some embodiments, the outer diameter 64 of the dog point 36 is between about 95.5% to about 99.5% of the minor diameter 60, 160, 260. A radius or chamfer 66, as defined by angle θ , may be provided extending from a front end 68 of the dog point 36.

[0038] In a first embodiment as shown in FIGS. 1 and 2, the driver attachment 44 on the draw stud 22 is suitable for being coupled to a driver 32 formed of a ratchet wrench which includes a bearing 70 as is known in the art. The ratchet wrench is manually actuated. The bearing 70 is positioned on an unthreaded section 72 of the central section 48, and an enlarged head 74 of the draw stud 22 having a plurality of flats is provided at an end of the unthreaded section 72. In use, the bearing 70 is positioned between the enlarged head 74 and the punch 26. The driver 32 couples with the flats on the enlarged head 74 in a known manner. In a second embodiment as shown in FIGS. 3 and 4, the driver attachment 44a on the draw stud 22 is suitable for being coupled to a driver 32a formed of a hydraulically driven tool. The hydraulically driven tool may be battery powered or manually operated. Examples of such a hydraulically driven tool include, but are not limited to, a Greenlee® Hydraulic Hand Pump, Greenlee® Hydraulic Foot Pump with Hydraulic Knockout Ram. In this embodiment, the driver attachment 44a on the draw stud 22 is a single conventional external helical thread 76. The major diameter of the thread 76 forming the driver attachment 44a may be the same as, or less than, the outer diameter of the central section 48. Other suitable means may be provided for attaching the driver 32, 32a to the draw stud 22 are within the scope of the present disclosure.

[0039] The die 24 is conventionally formed and includes a base wall 80 and a circular side wall 82 extending from the outer perimeter of the base wall 80. A recess 84 is provided by the inner surface of the base wall 80 and the side wall 82, and the recess 84 is in communication with an unthreaded central passageway 86 extending through the base wall 80. The central passageway 86 has a diameter which is slightly greater than the outer diameter of the central section 48 of the draw stud 22.

[0040] As shown in FIG. 15, the punch 26 includes a body 90 having a front end 92 formed by

a cutting/punching edge as is known in the art and an opposite rear end 94. A wall forming a central passageway 96 extends through the center of the body 90 from the front end 92 to the rear end 94, and a longitudinal centerline axis 98 is defined through the central passageway 96. The passageway 96 has a counterbore 100 extending from the front end 92 to a threaded section 102 which extends to the rear end 94 of the body 90. The counterbore 100 has an unthreaded cylindrical surface 104 which extends from the front end 92 and an unthreaded cone-shaped lead-in surface 106 which extends from a rear end of the cylindrical surface 104 to the threaded section 102. The threaded section 102 is a multi-start internal thread formed by four intertwined coarse helical threads that mirror the threads 50, 52, 54, 56, formed by three intertwined coarse helical threads that mirror the threads 150, 152, 154, or formed by two intertwined coarse helical threads that mirror the threads 250, 252. The cylindrical surface 104 has a diameter 108 which is slightly greater than the major diameter 58, 158, 258 of the multi-start external thread 42, 142, 242. The counterbore 100 is about 2% to about 4% greater than the major diameter 58, 158, 258, and at a depth of between 0.25 and 2 times the magnitude of the major diameter 58, 158, 258.

[0041] The threaded section 102 threadedly mates with the multi-start external thread 42, 142, 242. The cone-shaped lead-in surface 106 extends at an angle μ of $45^\circ \pm 5^\circ$ relative to the centerline axis 98 when viewed in cross-section. Angle μ may be equal to approximately $90^\circ - \beta$.

[0042] The coarse helical threads 50, 52, 54, 56, threads 150, 152, 154, or threads 250, 252 on the draw stud 22 are standard Unified coarse threads which maximizes the pitch length of the threads 50, 52, 54, 56, threads 150, 152, 154, or threads 250, 252, while keeping the desired shear strength. By using coarse threads 50, 52, 54, 56, threads 150, 152, 154, or threads 250, 252, the minor diameter 60, 160, 260 of the multi-start external thread 42, 142, 242 is not reduced as occurs when fine threads are used, and as such, the shear strength of the draw stud 22 is not impacted. Typically, when reducing the number of rotations required to move an inch, a fine thread is replaced with a coarse thread to lower the threads per inch and increase the pitch length and lead of the thread. For example, one could change the draw stud 22 from a UNF .75-16 to an UNC .75-

10 thread. In the present disclosure, the multi-start external thread 42, 142, 242 maximizes the distance the punch 26 travels in a single rotation, while maintaining the shear strength of an equivalent single start thread form. This allows for the lead, or linear distance traveled in a single rotation, to be equal to the pitch multiplied by the number of starts. The four-start threads 50, 52, 54, 56 move about four times as far with a single rotation as a single start thread with equal threads per inch, the three-start threads 150, 152, 154 move about three times as far with a single rotation as a single start thread with equal threads per inch, and the two-start threads 250, 252 move about two times as far with a single rotation as a single start thread with equal threads per inch. Since the threads per inch was not lowered to obtain the desired linear distance per rotation, the shear strength characteristics of a typical UNF thread is maintained. As such, the multi-start thread 42, 142, 242 reduces the number of rotations need to fully fasten the punch 26 to the draw stud 22. This coarse thread pitch increases the travel distance of its respective UNF thread equivalent, while maintaining the internal and thread shear strength. This, combined with the multi-start thread 42, 142, 242, allows for the thread lead to be more than four times the pitch travel distance (coarse pitch multiplied by the number of starts equals distance traveled) for the four-start threads, allows for the thread lead to be more than three times the pitch travel distance (coarse pitch multiplied by the number of starts equals distance traveled) for the three-start threads, and allows for the thread lead to be more than two times the pitch travel distance (coarse pitch multiplied by the number of starts equals distance traveled) for the two-start threads. For example, a four-start thread can move more than four times as far as its UNF single start equivalent, a three-start thread can move more than three times as far as its UNF single start equivalent, and a two-start thread can move more than two times as far as its UNF single start equivalent. Therefore, the speed of assembly of the punch 26 with the draw stud 22 is at least two times faster than a single start thread per hole completion, and the speed of disassembly of the punch 26 from the draw stud 22 is at least two times faster than a single start thread per hole completion.

[0043] The friction between the draw stud 22 and the punch 26, combined with the angle α of

the intertwined helical threads 50, 52, 54, 56, threads 150, 152, 154, or threads 250, 252, is great enough to resist the reverse rotation of the punch 26 when the draw stud 22 and punch 26 are drawn toward the driver 32, 32a. As a result, the punch 26 and the draw stud 22 are self-locking when the punch 26 is threaded onto the draw stud 22. This prevents back-driving of the punch 26 when the draw stud 22 is being rotated.

[0044] In the embodiment which provides four intertwined coarse helical threads 50, 52, 54, 56, the start of the threading process of threading the punch 26 onto the draw stud 22 is improved over a single start thread since the four intertwined helical threads 50, 52, 54, 56 provide four starts at 90° versus one start at 360°, however, more torque is required versus a single thread. In the embodiment which provides three intertwined helical threads 150, 152, 154, the start of the threading process of threading the punch 26 onto the draw stud 22 is improved over a single start thread since the three intertwined helical threads 150, 152, 154 provide three starts at 120° versus one start at 360°, and less torque is required than in the embodiment where four intertwined coarse helical threads 50, 52, 54, 56 are used. In the embodiment which provides two intertwined coarse helical threads 250, 252, the start of the threading process of threading the punch 26 onto the draw stud 22 is improved over a single start thread since the two intertwined helical threads 250, 252 provide two starts at 180° versus one start at 360°, and less torque is required than in the embodiment where three intertwined coarse helical threads 150, 152, 154 are used.

[0045] The geometry of the dog point 36 and the counterbore 100 assists in the alignment of the draw stud 22 with the punch 26 and assists in preventing cross threading of the punch 26 and the draw stud 22. In an embodiment, the dog point 36 has a length of ¼” for both a 7/16-14 draw stud 22 and for a 3/4-10 draw stud 22. This provides sufficient length to align the draw stud 22 to the punch 26 and for part stability. Since the diameter 64 of the dog point 36 is reduced relative to the minor diameter 60, 160, 260 of the multi-start external thread 42, 142, 242 and the cone-shaped lead-in surface 62, 162, 262 is provided, this maximizes the area of the thread transition on cut thread transitions. The angle μ of the unthreaded cone-shaped lead-in surface 106 is the same

as the angle β of the cone-shaped lead-in surface 62, 162, 262 ($45^\circ \pm 5^\circ$). The combination of the transition angles and the dog point 36/counterbore 100 maximize the surface area contact of the threads 50, 52, 54, 56, the threads 150, 152, 154 or the threads 250, 252 with the threaded section 102 of the punch 26.

[0046] The provision of the dog point 36, the cone-shaped lead-in surface 62, 162, 262, and the geometry of the threads 50, 52, 54, 56, the threads 150, 152, 154, or the threads 250, 252 makes the punch 26 resistant to cross threading. The ease of function to assemble the punch 26 with the draw stud 22 is independent of the manufacturing process used to manufacture the punch 26 and draw stud 22. The threads 50, 52, 54, 56, the threads 150, 152, 154, or the threads 250, 252 can be created by forming the geometry or cutting the geometry works. Typically, internal threads are single point cut, or tapped, and external threads can be single point cut or roll threaded. The cone-shaped lead-in surface 62, 162, 262 and the counterbore 100 are machined independently of the threading operation making the mating surfaces compatible without concern of the processes utilized.

[0047] When the draw stud 22 is inserted into the punch 26, the cone-shaped lead-in surface 62, 162, 262 may engage with the central passageway 96 at the front end 92 and this causes the draw stud 22 to move inward toward the centerline axis 98 of the punch 26. As the draw stud 22 is further inserted into the punch 26, the cone-shaped lead-in surface 62, 162, 262 may engage with the cone-shaped lead-in surface 106 which causes the draw stud 22 to move until the centerline axis 40 of the draw stud 22 aligns with the centerline axis 98 of the punch 26. The cone-shaped lead-in surface 62, 162, 262 helps to align by creating a larger surface contact between the interface of the draw stud 22 and the punch 26.

[0048] Coarse threads are typically used in applications where a large torque load is generated and thread stripping or thread damage can result. This coarse pitch form is desirable for punching knockout applications, because the force used in punching are greatest in large diameter knockouts or in thicker plate steel. Coarse pitch threads have a deeper thread profile and the multi-start thread

has a smaller thread start geometry. The cone shapes of the lead-in surface 62, 162, 262 and the lead-in surface 106 deter misalignment of the matching thread profiles and better expose the thread start. This allows for the multi-start lead thread starts to find the prospective mating parts start. Multi-start threads have a tendency to cross-thread, making it difficult for the operator to begin assembly. With the present geometry, the dog point 36 finds the center of the passageway 96 of the punch 26, while the cone-shaped lead-in surface 62, 162, 262 completes the thread alignment process by axially aligning the draw stud 22 and the punch 26 together.

[0049] In an embodiment as shown in FIG. 14, the dog point 36 is eliminated. In this embodiment, during assembly of the draw stud 22 with the punch 26, the cone-shaped lead-in surface 62, 162, 262 engages with the passageway 96 at the front end 92 and this causes the draw stud 22 to move inward toward the centerline axis 98 of the punch 26. As the draw stud 22 is further inserted into the punch 26, the cone-shaped lead-in surface 62, 162, 262 engages with the cone-shaped lead-in surface 106 which causes the draw stud 22 to move until the centerline axis 40 of the draw stud 22 aligns with the centerline axis 98 of the punch 26. The cone-shaped lead-in surface 62, 162, 262 helps to align by creating a larger surface contact between the interface of the draw stud 22 and the punch 26.

[0050] FIGS. 17-22 depict graphs showing the torque output of three different sizes of punches 26, namely a 1/2" punch 26 (FIGS. 17 and 18), a 3/4" punch 26 (FIGS. 19 and 20), and a 2" punch 26 (FIGS. 21 and 22) over the number of 90° rotations. Each graph depicts the three-start thread 142 and a single start thread. Mild steel plate was used, and the graphs show the operator manually rotating the driver 44 90° for each turn. A torque transducer was used to read the torque output at each rotational interval. FIGS. 17, 19 and 21 show graphs of the results which had the thickest plate (10 GA and 12 GA) tested. FIGS. 18, 20 and 22 show graphs of the results which had the thinner plate (14 GA) tested. Steel plate was not used for the 2" punch test for the 10 GA. As shown in each graph, the maximum amount of torque was generated in a much fewer number of rotations using the multi-start external thread 142 versus a single thread (this holds true for the

other multi-start threads 42, 242). As shown in the graphs, when a hole is made in the thicker steel, FIGS. 17, 19 and 21, the multi-start thread 142 has a lower peak torque during manual hole-making than the prior art single start thread. The overall work for making a hole with the multi-start thread 42, 142, 242 is less than the single start thread because of the dramatically fewer turns that the operator needs to turn in order to make the hole.

[0051] Many modifications and other embodiments of the disclosure set forth herein will come to mind to one skilled in the art to which these disclosed embodiments pertain having the benefit of the teachings presented in the foregoing descriptions and the associated drawings. Therefore, it is to be understood that the disclosure is not to be limited to the specific embodiments disclosed herein and that modifications and other embodiments are intended to be included within the scope of the disclosure. Moreover, although the foregoing descriptions and the associated drawings describe example embodiments in the context of certain example combinations of elements and/or functions, it should be appreciated that different combinations of elements and/or functions may be provided by alternative embodiments without departing from the scope of the disclosure. In this regard, for example, different combinations of elements and/or functions than those explicitly described above are also contemplated within the scope of the disclosure. Although specific terms are employed herein, they are used in a generic and descriptive sense only and not for purposes of limitation.

[0052] While particular embodiments are illustrated in and described with respect to the drawings, it is envisioned that those skilled in the art may devise various modifications without departing from the spirit and scope of the appended claims. It will therefore be appreciated that the scope of the disclosure and the appended claims is not limited to the specific embodiments illustrated in and discussed with respect to the drawings and that modifications and other embodiments are intended to be included within the scope of the disclosure and appended drawings. Moreover, although the foregoing descriptions and the associated drawings describe example embodiments in the context of certain example combinations of elements and/or

functions, it should be appreciated that different combinations of elements and/or functions may be provided by alternative embodiments without departing from the scope of the disclosure and the appended claims.

WHAT IS CLAIMED IS:

1. A combination which is configured for use in punching holes in sheet metal comprising:
a punch including a body having a punching edge and a wall forming a passageway therethrough, the wall having a multi-start thread formed thereon; and
a draw stud comprising an elongated cylinder having a multi-start thread thereon which is configured to be coupled to the multi-start thread of the punch, wherein a number of starts provided on the punch corresponds to a number of starts provided on the draw stud, and the multi-start thread on the punch is engaged with the multi-start thread on the draw stud in use.
2. The combination of claim 1, wherein the multi-start thread of the punch comprises two intertwined threads and the multi-start thread of the draw stud comprises two intertwined threads.
3. The combination of claim 1, wherein the multi-start thread of the punch comprises three intertwined threads and the multi-start thread of the draw stud comprises three intertwined threads.
4. The combination of claim 1, wherein the multi-start thread of the punch comprises four intertwined threads and the multi-start thread of the draw stud comprises four intertwined threads.
5. The combination of claim 1, wherein the draw stud further includes an unthreaded dog point extending from the elongated cylinder, the dog point having a diameter which is less than a minor diameter of the multi-start thread of the draw stud.
6. The combination of claim 5, further comprising a generally cone-shaped lead-in surface at a front end of the multi-start thread of the draw stud, and wherein the wall forming the passageway

of the punch includes a counterbore having an unthreaded cylindrical surface extending from a front end of the punch and a cone-shaped lead-in surface extending between the cylindrical surface and the multi-start thread of the punch, the cone-shaped lead-in surface and the cone-shaped lead-in surface having complementary angles.

7. The combination of claim 1, wherein the draw stud includes a generally cone-shaped lead-in surface at a front end of the multi-start thread of the draw stud, and wherein the wall forming the passageway of the punch includes a counterbore having an unthreaded cylindrical surface extending from a front end of the punch and a cone-shaped lead-in surface extending between the cylindrical surface and the multi-start thread of the punch, the cone-shaped lead-in surface and the cone-shaped lead-in surface having complementary angles.

8. The combination of claim 1, wherein the multi-start thread of the punch comprises at least two intertwined threads and the multi-start thread of the draw stud comprises at least two intertwined threads.

9. The combination of claim 8, in combination with a die mounted on the draw stud.

10. The combination of claim 9, in combination with a manually driven wrench coupled to the draw stud and configured to be engaged with the die.

11. The combination of claim 10, wherein the draw stud has a single thread thereon to which the manually driven wrench is coupled.

12. The combination of claim 8, in combination with a hydraulic driver coupled to the draw stud and configured to be engaged with the die.

13. The combination of claim 12, wherein the draw stud has a single thread thereon to which the hydraulic driver is coupled.
14. The combination of claim 1, wherein a multi-start thread is formed from coarse threads.
15. The combination of claim 1, wherein a multi-start thread is formed from standard Unified coarse threads.
16. The combination of claim 1, wherein each thread of the multi-start thread has a thread angle α defined by a 60° included thread form.
17. A method of punching a hole comprising:
forming a pilot hole in sheet metal;
attaching a draw stud to a driver;
sliding a die over a free end of the draw stud until the die is proximate to the driver;
inserting the free end of the draw stud through the pilot hole until the die is seated against one side of the sheet metal and engaged with the driver;
engaging a multi-start thread of a knockout punch with a multi-start thread of the draw stud, wherein a number of starts provided on the punch corresponds to a number of starts provided on the draw stud;
rotating the knockout punch in a first direction to thread the knockout punch onto the free end of the draw stud until the knockout punch impinges onto a side of the sheet metal opposite the side on which the die is located; and
actuating the driver to draw the draw stud and the knockout punch toward the die and to puncture and cut the sheet metal and produce a final hole.

18. The method of claim 17, wherein the knockout punch is manually rotated onto the draw stud.

19. The method of claim 17, further comprising engaging an unthreaded dog point of the draw stud with a counterbore of the punch, wherein the dog point first engages with an unthreaded cylindrical surface of the counterbore and thereafter engages with a generally cone-shaped lead-in surface of the counterbore, wherein the engagement of the dog point occurs prior to engagement of the multi-start thread of the knockout punch with the multi-start thread of the draw stud.

20. The method of claim 17, further comprising generally cone-shaped lead-in surface of the draw stud with a generally cone-shaped lead-in surface of the punch, wherein the engagement of the generally cone-shaped lead-in surfaces occurs prior to engagement of the multi-start thread of the knockout punch with the multi-start thread of the draw stud.

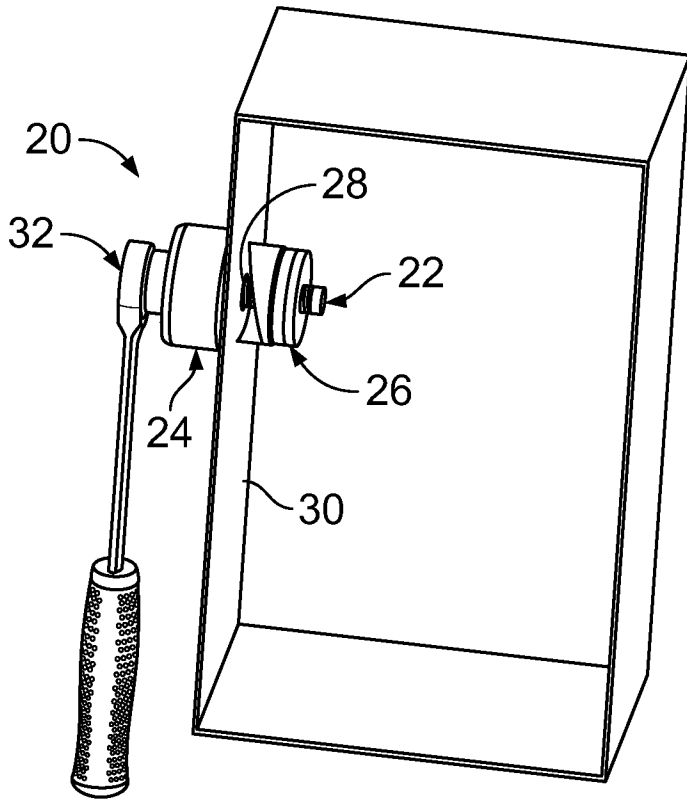

FIG. 1

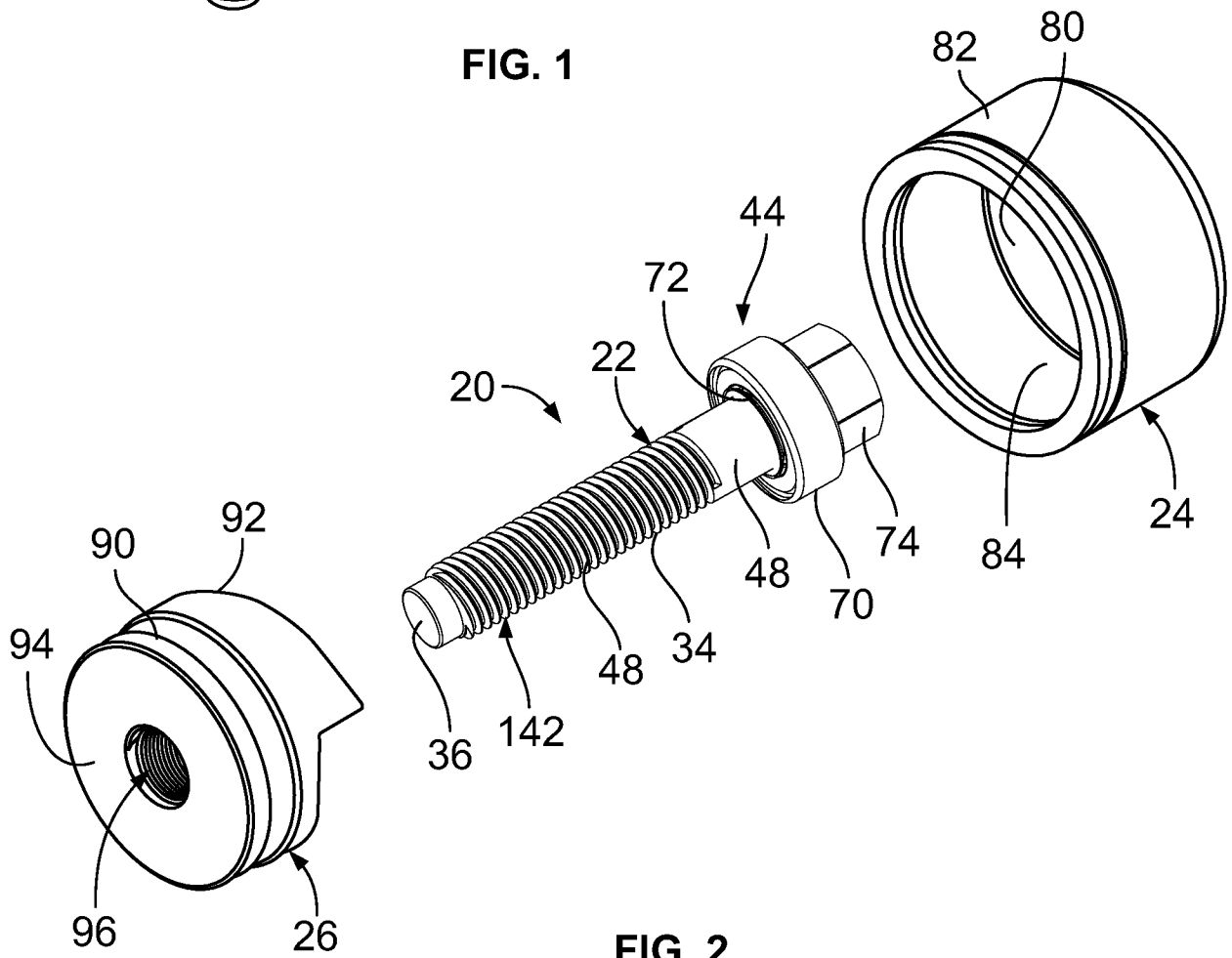

FIG. 2

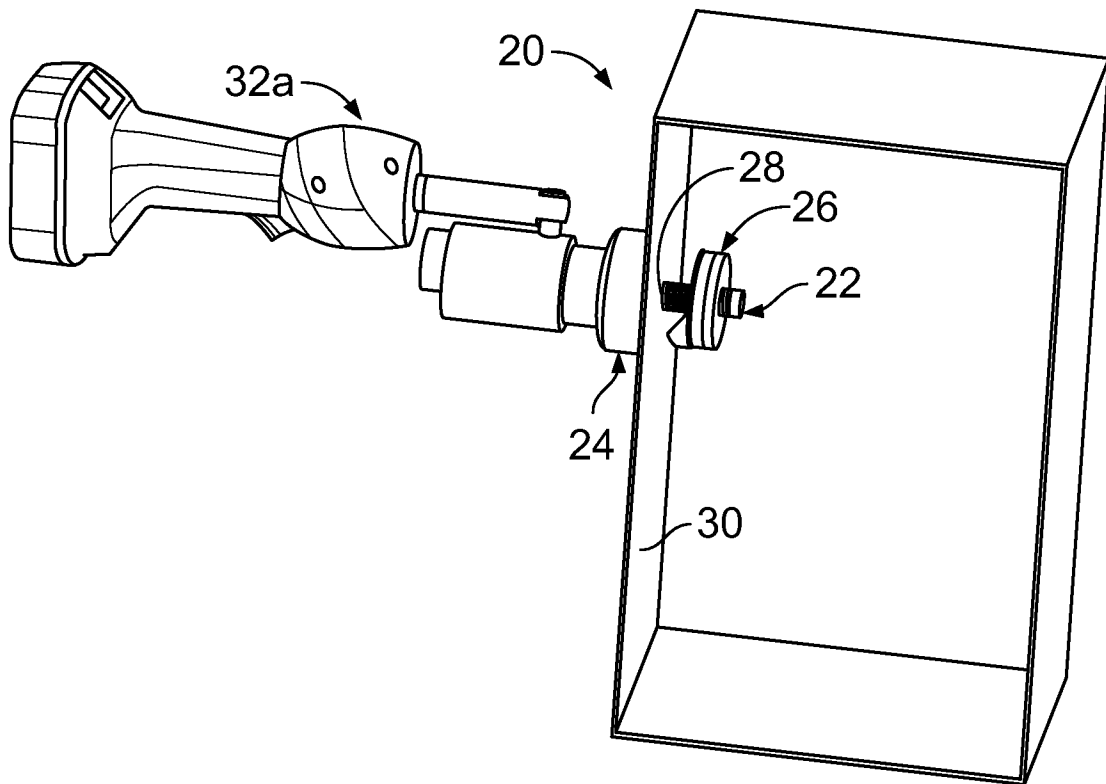

FIG. 3

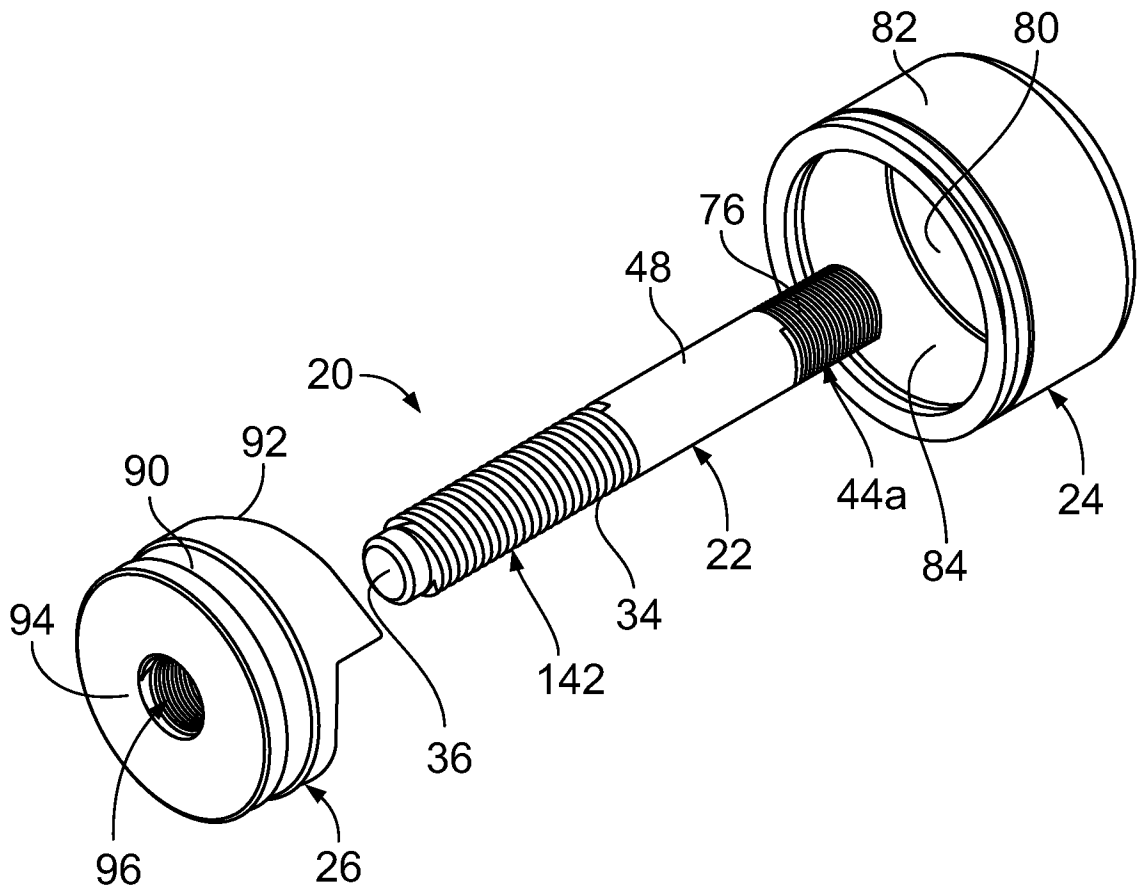

FIG. 4

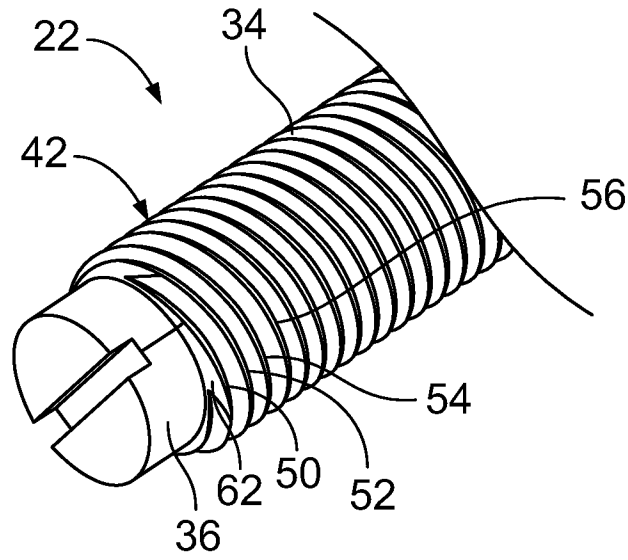

FIG. 5

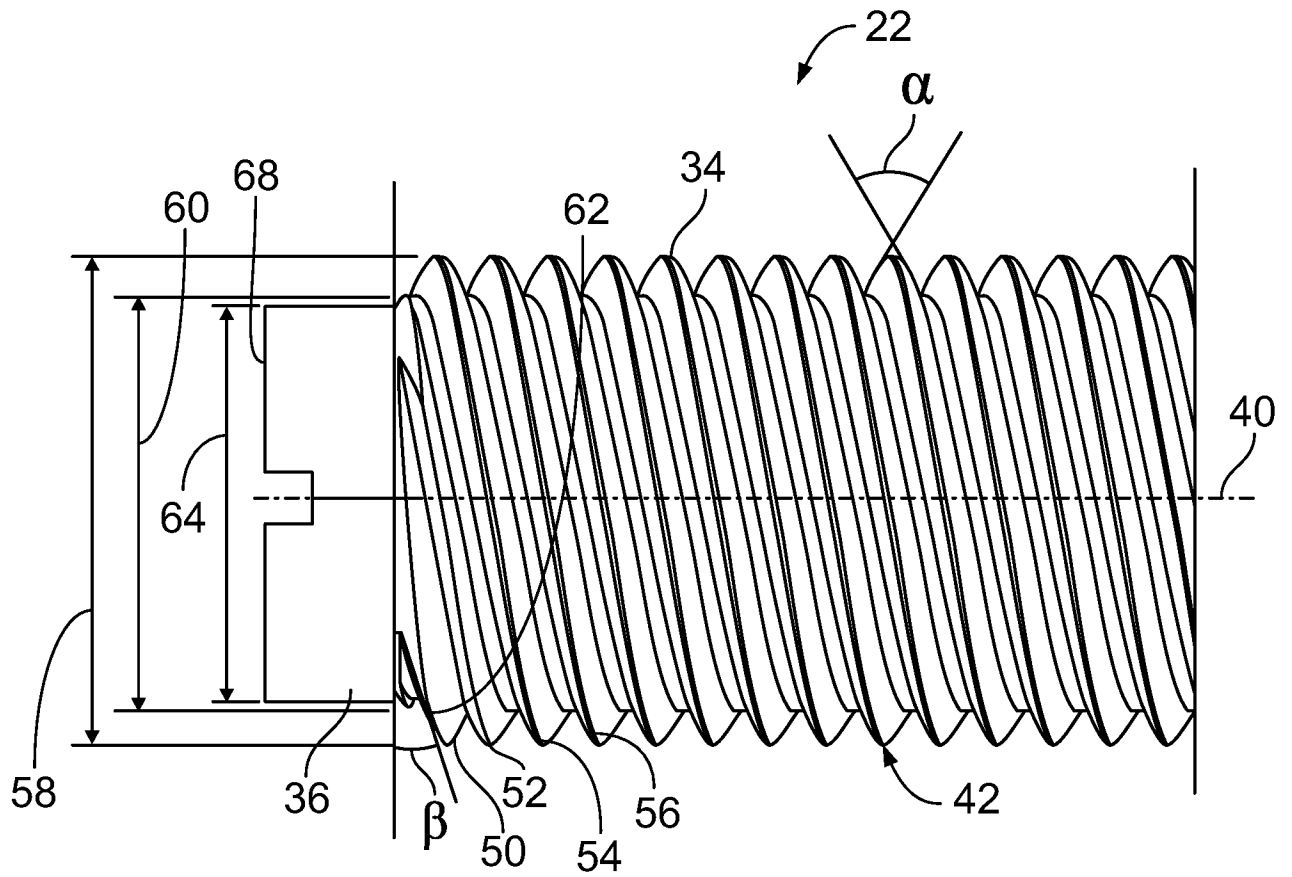

FIG. 6

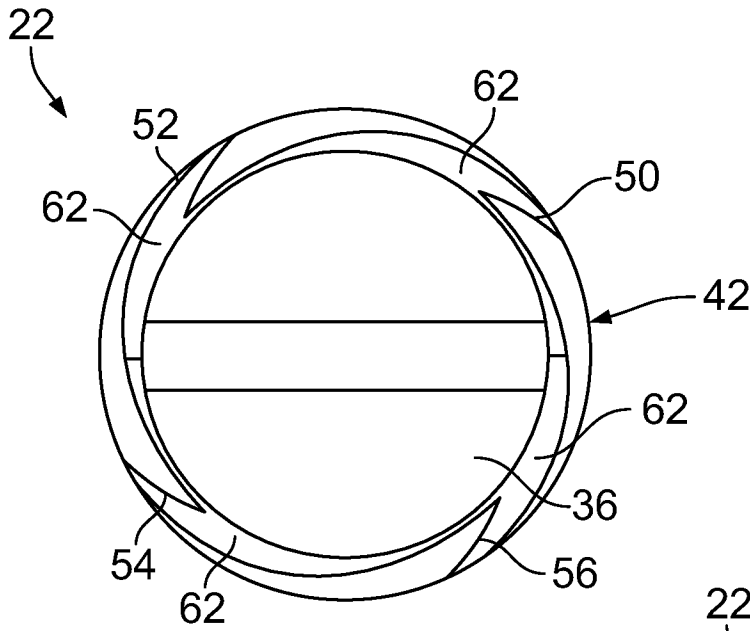

FIG. 7

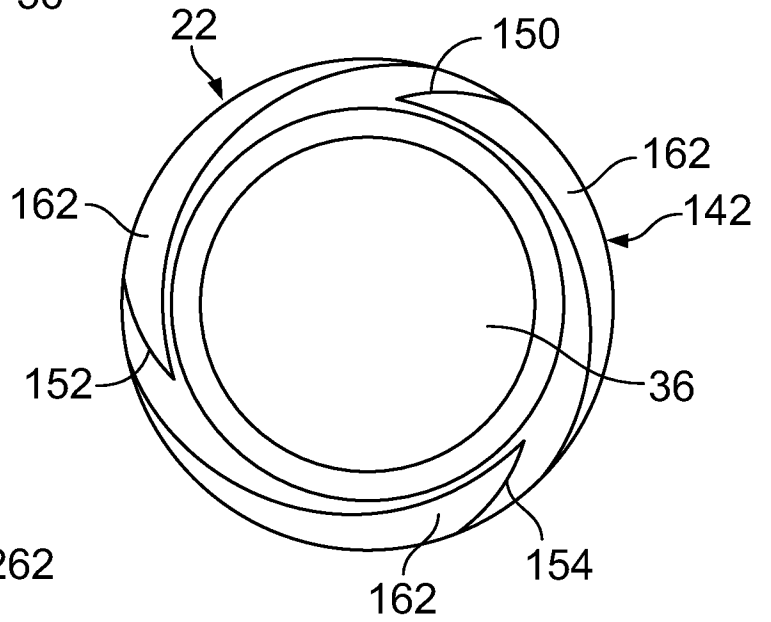

FIG. 10

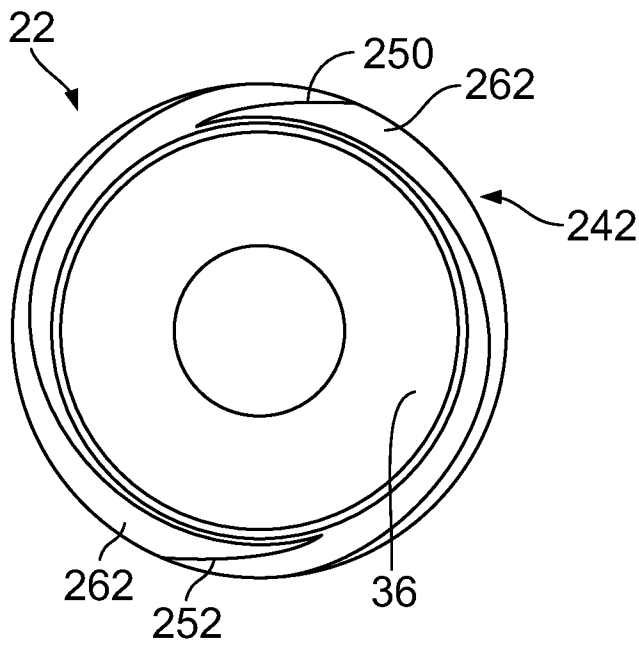

FIG. 13

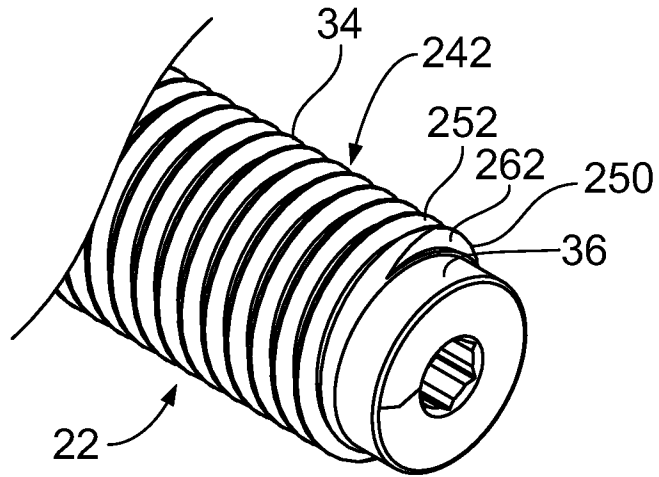

FIG. 11

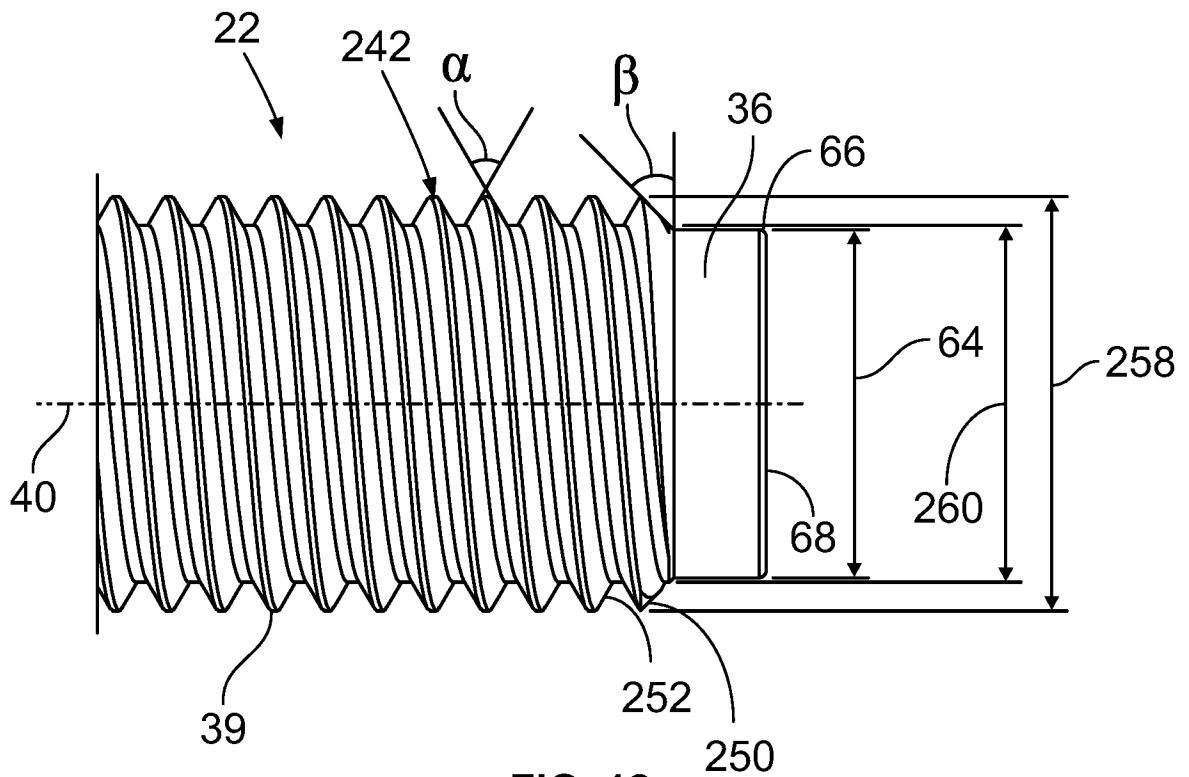

FIG. 12

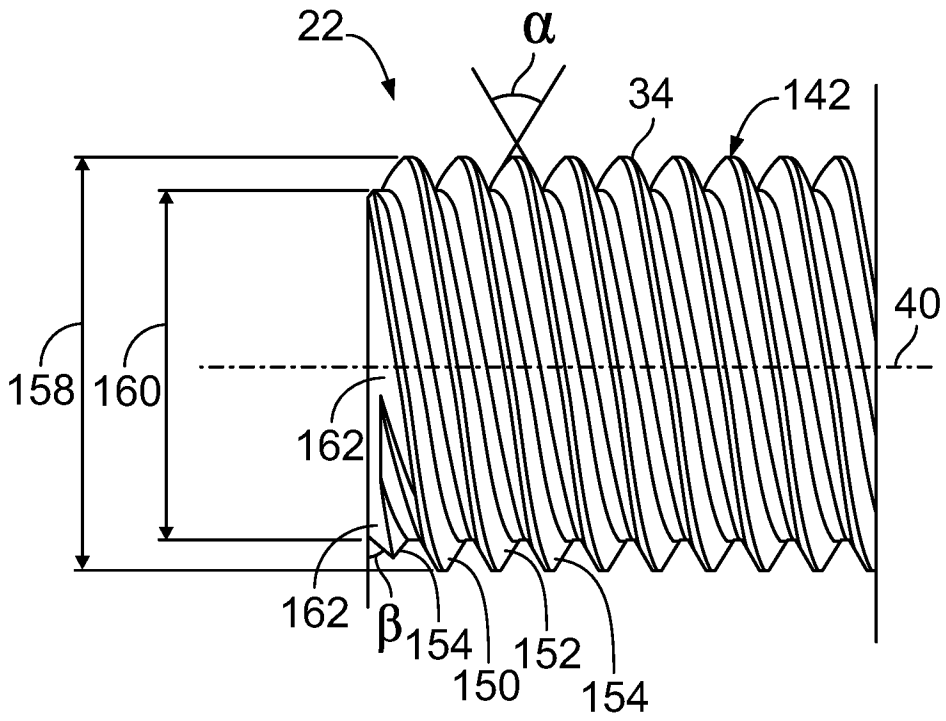

FIG. 14

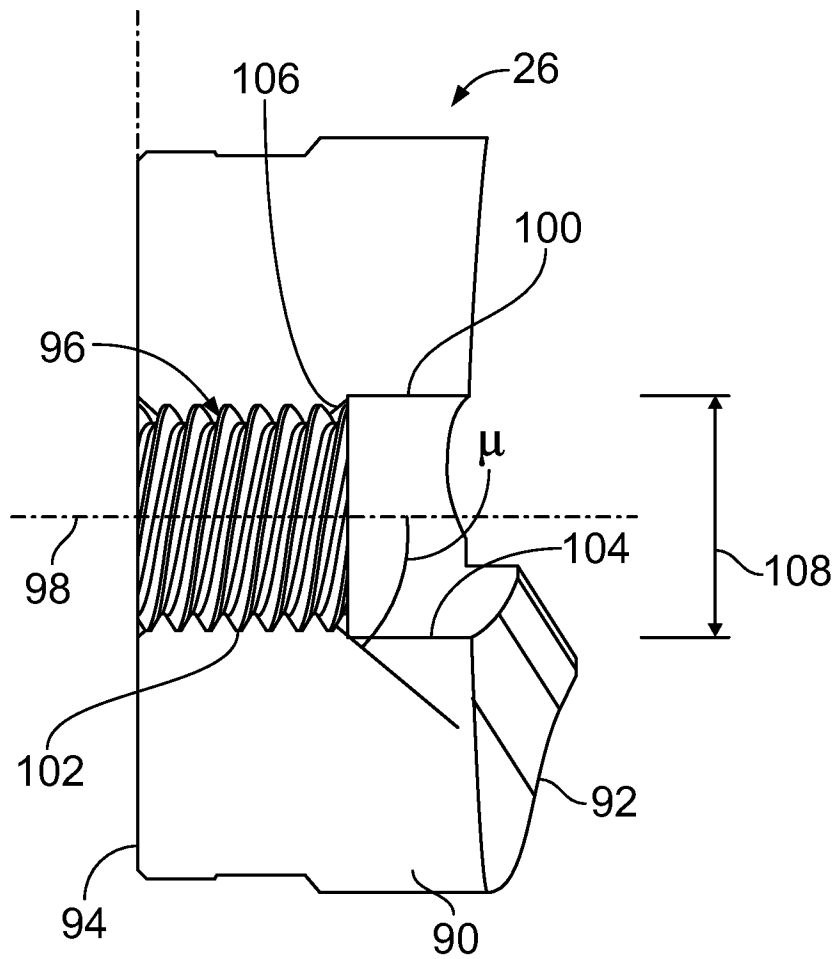

FIG. 15

9/11

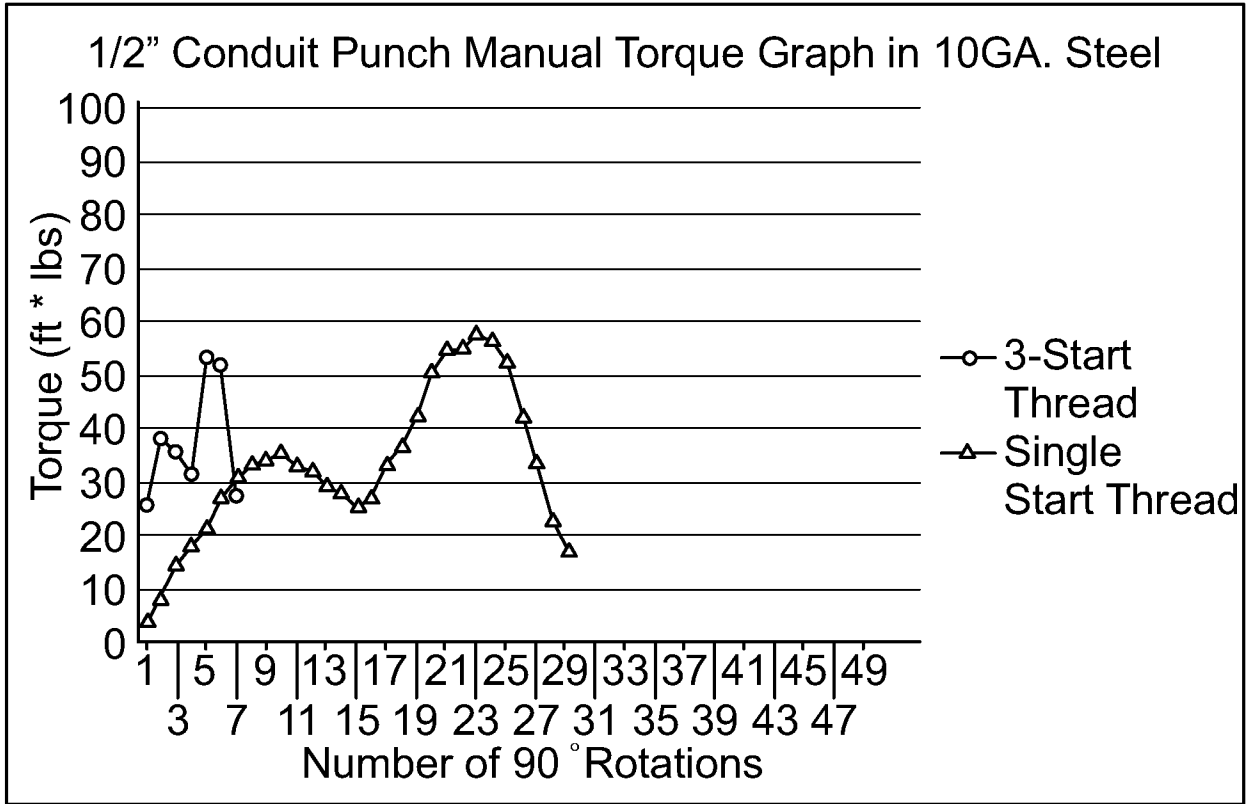

FIG. 17

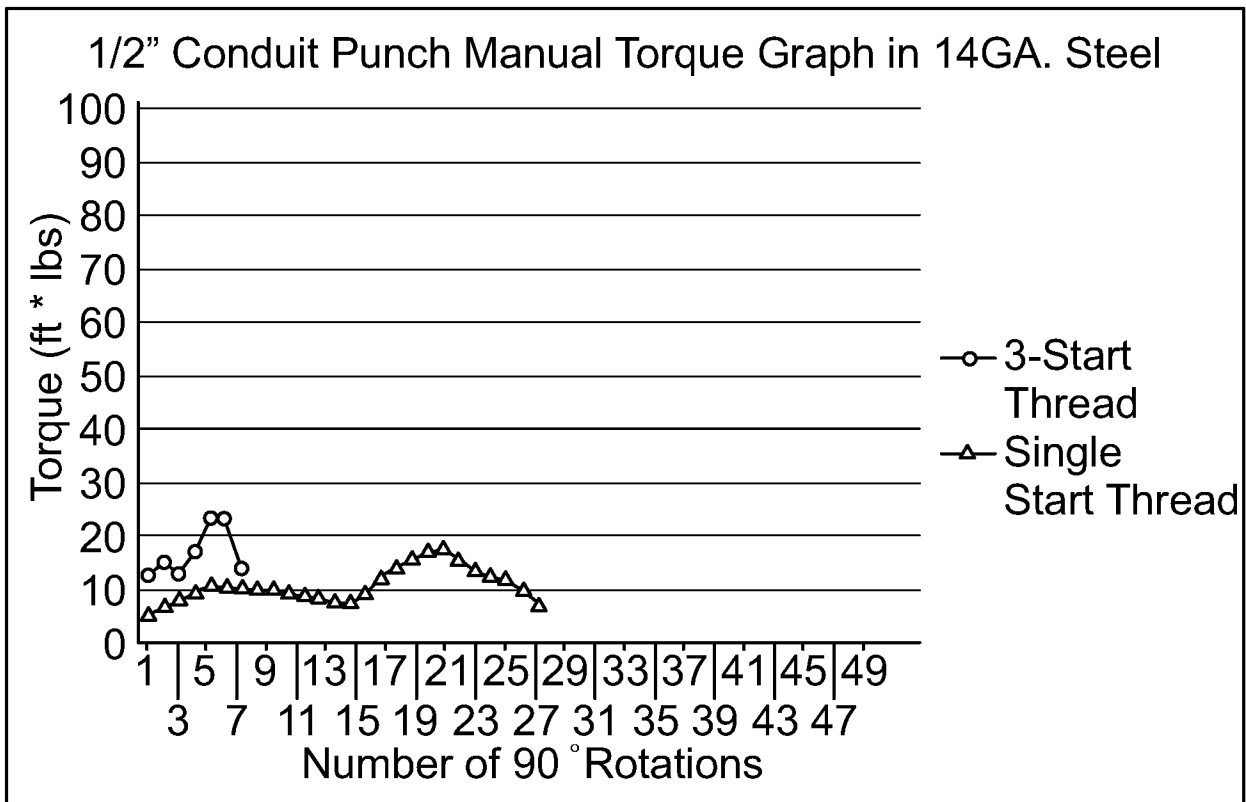

FIG. 18

10/11

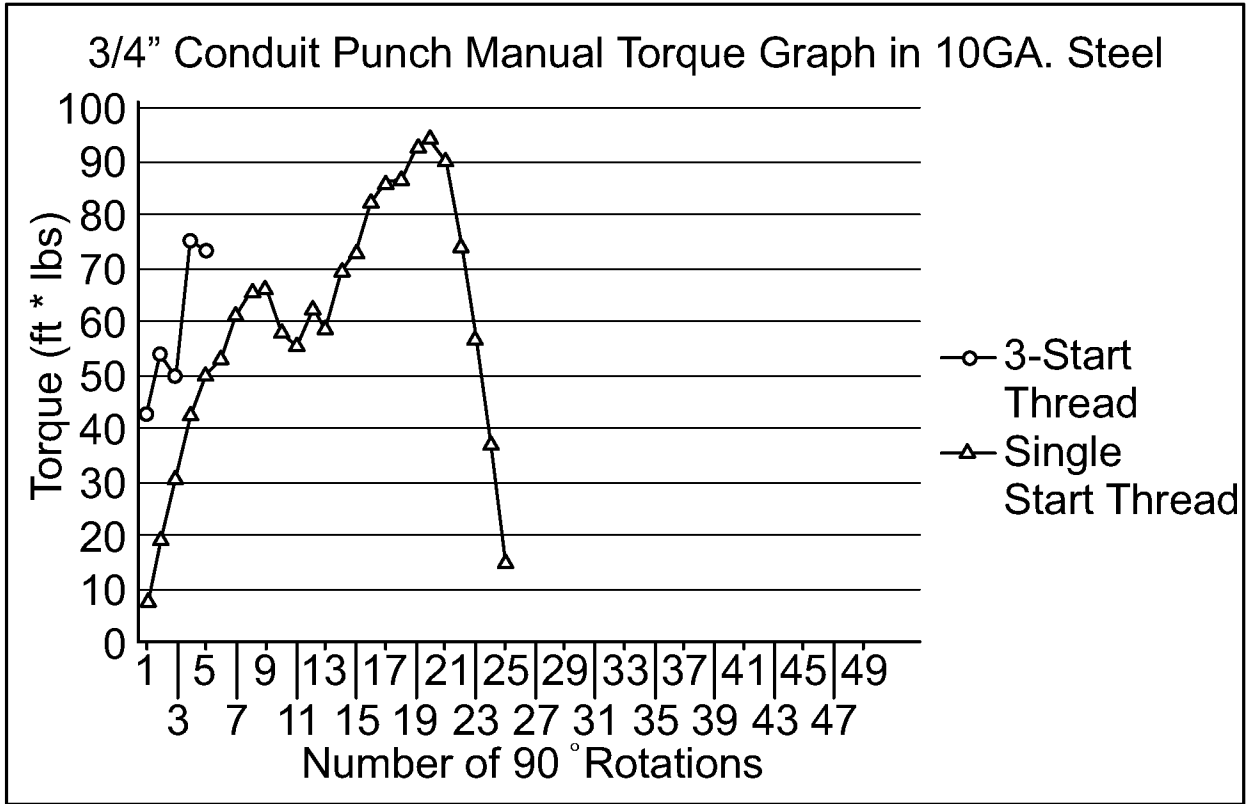

FIG. 19

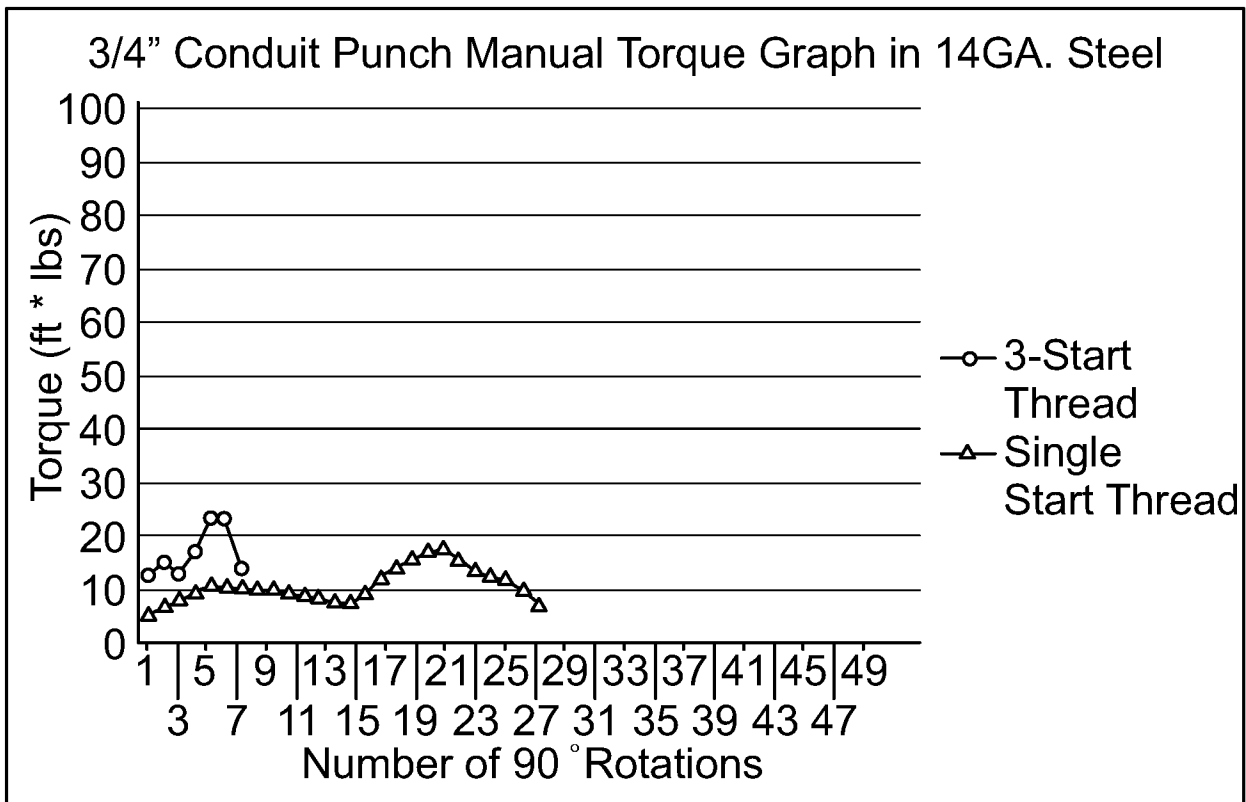

FIG. 20

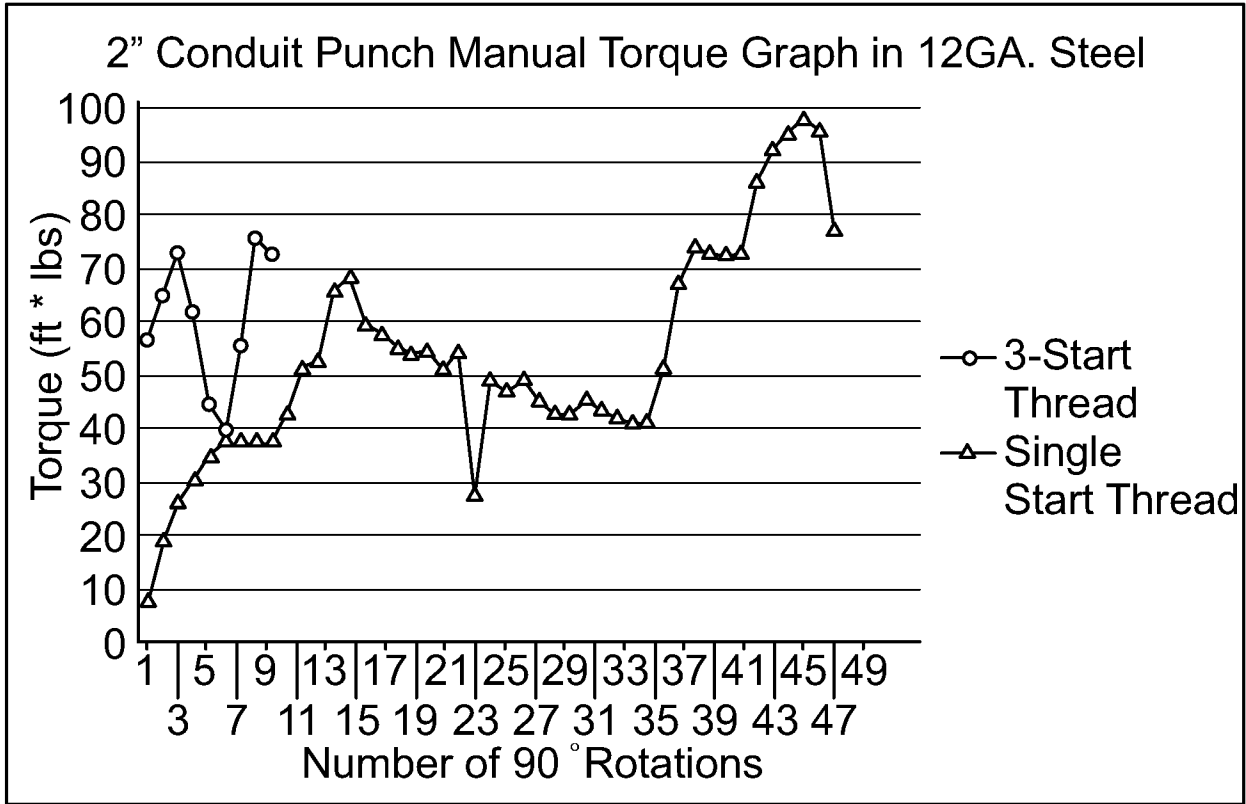

FIG. 21

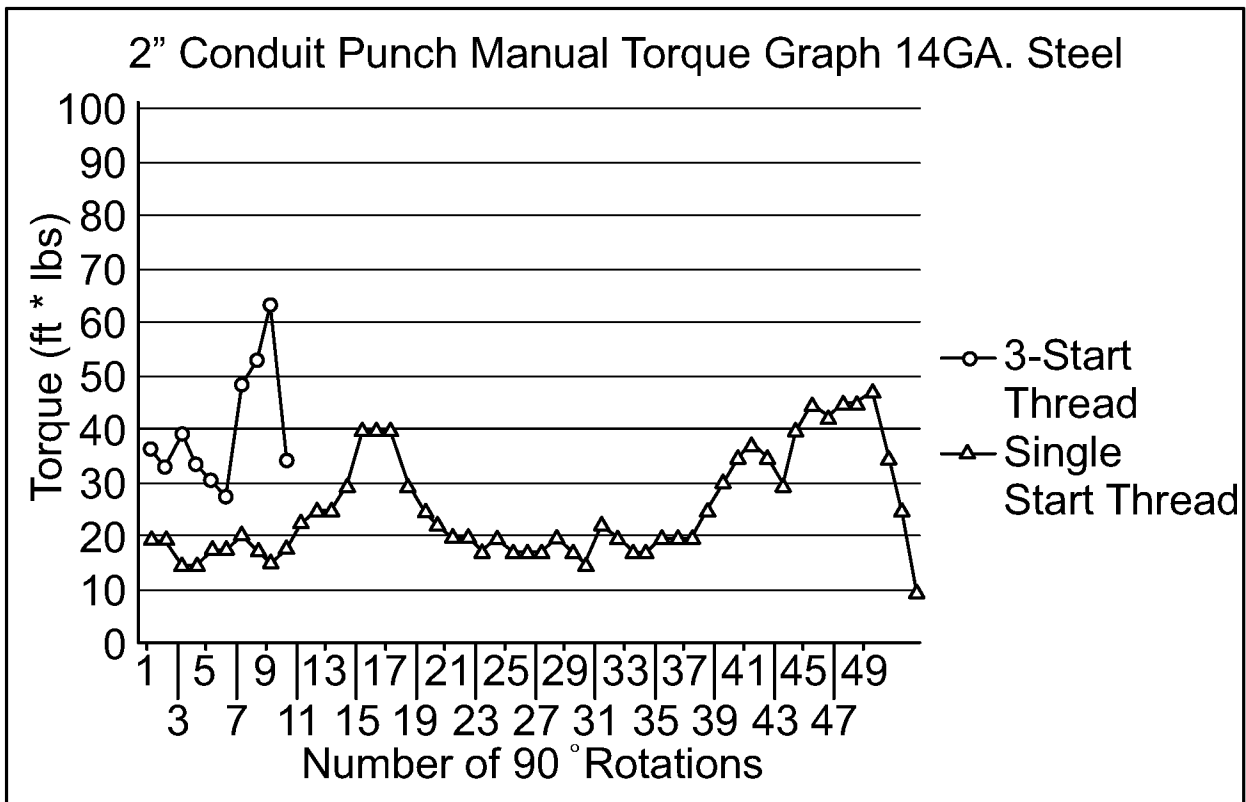

FIG. 22

INTERNATIONAL SEARCH REPORT

International application No.

PCT/US2022/039026

A. CLASSIFICATION OF SUBJECT MATTER		
B23D 35/00(2006.01)i; B23P 11/00(2006.01)i; B21D 28/34(2006.01)i; B26F 1/14(2006.01)i; B26F 1/38(2006.01)i		
According to International Patent Classification (IPC) or to both national classification and IPC		
B. FIELDS SEARCHED		
Minimum documentation searched (classification system followed by classification symbols) B23D 35/00(2006.01); B21D 28/34(2006.01); B23P 11/00(2006.01); B23P 19/00(2006.01); B26F 1/08(2006.01); B26F 1/14(2006.01); F16B 33/02(2006.01)		
Documentation searched other than minimum documentation to the extent that such documents are included in the fields searched Korean utility models and applications for utility models Japanese utility models and applications for utility models		
Electronic data base consulted during the international search (name of data base and, where practicable, search terms used) eKOMPASS(KIPO internal) & Keywords: punch, hole, draw stud, passageway, thread, cylinder, multi-start thread, intertwine d, dog point, cone, driver		
C. DOCUMENTS CONSIDERED TO BE RELEVANT		
Category*	Citation of document, with indication, where appropriate, of the relevant passages	Relevant to claim No.
Y	US 2013-0145916 A1 (GREENLEE TEXTRON INC.) 13 June 2013 (2013-06-13) paragraphs [0025]-[0033], [0051] and figures 1-4, 8	1-20
Y	US 7401394 B1 (MULLER, RUDOLF) 22 July 2008 (2008-07-22) column 4, lines 4-29, column 7, line 48 - column 8, line 10, and figures 1-3	1-20
Y	US 2015-0052735 A1 (ATLAS BOLT & SCREW COMPANY L.L.C.) 26 February 2015 (2015-02-26) paragraph [0017] and figure 5	2-4,8-13
A	EP 2208553 A2 (GREENLEE TEXTRON INC.) 21 July 2010 (2010-07-21) paragraphs [0015]-[0017] and figures 5-8	1-20
A	JP 01-310899 A (GREENLEE TEXTRON INC.) 14 December 1989 (1989-12-14) claim 1 and figure 8	1-20
<input type="checkbox"/> Further documents are listed in the continuation of Box C. <input checked="" type="checkbox"/> See patent family annex.		
* Special categories of cited documents: "A" document defining the general state of the art which is not considered to be of particular relevance "D" document cited by the applicant in the international application "E" earlier application or patent but published on or after the international filing date "L" document which may throw doubts on priority claim(s) or which is cited to establish the publication date of another citation or other special reason (as specified) "O" document referring to an oral disclosure, use, exhibition or other means "P" document published prior to the international filing date but later than the priority date claimed "T" later document published after the international filing date or priority date and not in conflict with the application but cited to understand the principle or theory underlying the invention "X" document of particular relevance; the claimed invention cannot be considered novel or cannot be considered to involve an inventive step when the document is taken alone "Y" document of particular relevance; the claimed invention cannot be considered to involve an inventive step when the document is combined with one or more other such documents, such combination being obvious to a person skilled in the art "&" document member of the same patent family		
Date of the actual completion of the international search 17 November 2022		Date of mailing of the international search report 18 November 2022
Name and mailing address of the ISA/KR Korean Intellectual Property Office 189 Cheongsa-ro, Seo-gu, Daejeon 35208, Republic of Korea Facsimile No. +82-42-481-8578		Authorized officer PARK, Tae Wook Telephone No. +82-42-481-3405

INTERNATIONAL SEARCH REPORT
Information on patent family members

International application No.

PCT/US2022/039026

Patent document cited in search report			Publication date (day/month/year)	Patent family member(s)			Publication date (day/month/year)
US	2013-0145916	A1	13 June 2013	CA	2797352	A1	09 June 2013
				US	2013-0145915	A1	13 June 2013
				US	8904911	B2	09 December 2014
				US	9254526	B2	09 February 2016
<hr/>							
US	7401394	B1	22 July 2008	AU	7214296	A	17 April 1997
				BR	9610709	A	13 July 1999
				CA	2232295	A1	03 April 1997
				CA	2232295	C	29 November 2005
				CN	1105832	C	16 April 2003
				CN	1200688	A	02 December 1998
				DE	19535537	A1	27 March 1997
				DE	69630901	T2	02 September 2004
				EP	0958100	A1	24 November 1999
				EP	0958100	B1	26 November 2003
				JP	11-511543	A	05 October 1999
				JP	4052669	B2	27 February 2008
				KR	10-0460232	B1	20 April 2005
				KR	10-1999-0063694	A	26 July 1999
				MX	9802172	A	30 August 1998
				WO	97-11811	A1	03 April 1997
<hr/>							
US	2015-0052735	A1	26 February 2015	CA	2733402	A1	02 September 2011
				CA	2733402	C	13 December 2016
				CA	2807920	A1	01 September 2013
				CA	2966841	A1	12 May 2016
				CN	102207123	A	05 October 2011
				CN	102207123	B	16 December 2015
				CN	103362220	A	23 October 2013
				CN	103362220	B	03 November 2017
				CN	107076196	A	18 August 2017
				MX	2011002363	A	21 September 2011
				MX	2013002402	A	13 September 2013
				MX	2017005826	A	11 January 2018
				MX	357943	B	31 July 2018
				US	2011-0217145	A1	08 September 2011
				US	2012-0207564	A1	16 August 2012
				US	2014-0090233	A1	03 April 2014
				US	8904622	B2	09 December 2014
US	8931163	B2	13 January 2015				
US	9353784	B2	31 May 2016				
WO	2016-073339	A1	12 May 2016				
<hr/>							
EP	2208553	A2	21 July 2010	BR	PI1000952	A2	18 November 2014
				CA	2690535	A1	20 July 2010
				CN	101791653	A	04 August 2010
				EP	2208553	A3	10 November 2010
				KR	10-2010-0085876	A	29 July 2010
				TW	201039937	A	16 November 2010
				US	2010-0180744	A1	22 July 2010
<hr/>							
JP	01-310899	A	14 December 1989	DE	68905200	T2	17 June 1993
				EP	0325442	A2	26 July 1989

INTERNATIONAL SEARCH REPORT
Information on patent family members

International application No.

PCT/US2022/039026

Patent document cited in search report	Publication date (day/month/year)	Patent family member(s)	Publication date (day/month/year)
		EP 0325442 B1	10 March 1993
		JP 01-310899 A	14 December 1989
		JP 2838709 B2	16 December 1998
		US 4899447 A	13 February 1990
<hr/>			