



(51) International Patent Classification:

A61M 16/04 (2006.01) A61M 15/00 (2006.01)  
A61M 1/00 (2006.01) A61M 16/00 (2006.01)  
A61M 11/00 (2006.01) A61M 16/06 (2006.01)

(21) International Application Number:

PCT/US2019/057008

(22) International Filing Date:

18 October 2019 (18.10.2019)

(25) Filing Language:

English

(26) Publication Language:

English

(30) Priority Data:

62/747,520 18 October 2018 (18.10.2018) US

(71) Applicant: THE BOARD OF REGENTS OF THE

UNIVERSITY OF TEXAS SYSTEM [US/US]; 210 West  
7th Street, Austin, Texas 78701 (US).

(72) Inventors: AKHTER, Forhad; One UTSA Circle, NPB

2.116, San Antonio, Texas 78249 (US). SCHOPPE, Austin  
R.; One UTSA Circle, NPB 2.116, San Antonio, Texas  
78249 (US). NAVARRO, Omar; One UTSA Circle, NPB

2.116, San Antonio, Texas 78249 (US). ADAMS, Bruce;  
One UTSA Circle, NPB 2.116, San Antonio, Texas 78249  
(US). FENG, Yusheng; One UTSA Circle, NPB 2.116, San  
Antonio, Texas 78249 (US). DELORENZO, Robert; One  
UTSA Circle, NPB 2.116, San Antonio, Texas 78249 (US).  
HOOD, Robert L.; One UTSA Circle, NPB 2.116, San An-  
tonio, Texas 78249 (US).

(74) Agent: LANDRUM, Charles; 98 San Jacinto Blvd., Suite  
1100, Austin, Texas 78701 (US).

(81) Designated States (unless otherwise indicated, for every  
kind of national protection available): AE, AG, AL, AM,  
AO, AT, AU, AZ, BA, BB, BG, BH, BN, BR, BW, BY, BZ,  
CA, CH, CL, CN, CO, CR, CU, CZ, DE, DJ, DK, DM, DO,  
DZ, EC, EE, EG, ES, FI, GB, GD, GE, GH, GM, GT, HN,  
HR, HU, ID, IL, IN, IR, IS, JO, JP, KE, KG, KH, KN, KP,  
KR, KW, KZ, LA, LC, LK, LR, LS, LU, LY, MA, MD, ME,  
MG, MK, MN, MW, MX, MY, MZ, NA, NG, NI, NO, NZ,  
OM, PA, PE, PG, PH, PL, PT, QA, RO, RS, RU, RW, SA,  
SC, SD, SE, SG, SK, SL, SM, ST, SV, SY, TH, TJ, TM, TN,  
TR, TT, TZ, UA, UG, US, UZ, VC, VN, ZA, ZM, ZW.

(84) Designated States (unless otherwise indicated, for every  
kind of regional protection available): ARIPO (BW, GH,

(54) Title: METHODS, APPARATUSES, AND SYSTEMS FOR ASPIRATING AIRWAYS

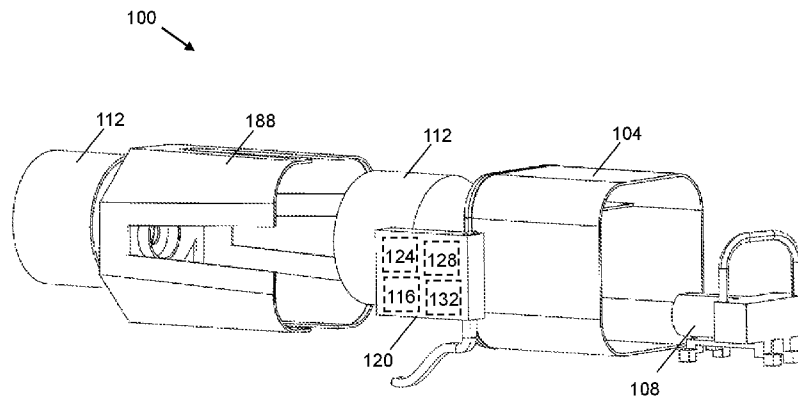

FIG. 1

(57) Abstract: The present disclosure includes methods, apparatuses, and systems for aspirating the airway of a patient. The apparatus includes a main body having a pump and a storage canister housing coupled to the main body and containing a storage container that is at least partially collapsible. In some configurations, the main body can include a pressure sensor, a controller in communication with the pressure sensor, and having a processor, a memory, and a power source in communication with the controller. The storage canister housing can include a first end coupled to the main body, and a second end having a weighted portion and configured to be coupled to the first end to permit free rotation, such that the second end gravitationally rotates.



GM, KE, LR, LS, MW, MZ, NA, RW, SD, SL, ST, SZ, TZ, UG, ZM, ZW), Eurasian (AM, AZ, BY, KG, KZ, RU, TJ, TM), European (AL, AT, BE, BG, CH, CY, CZ, DE, DK, EE, ES, FI, FR, GB, GR, HR, HU, IE, IS, IT, LT, LU, LV, MC, MK, MT, NL, NO, PL, PT, RO, RS, SE, SI, SK, SM, TR), OAPI (BF, BJ, CF, CG, CI, CM, GA, GN, GQ, GW, KM, ML, MR, NE, SN, TD, TG).

**Declarations under Rule 4.17:**

- *as to applicant's entitlement to apply for and be granted a patent (Rule 4.17(ii))*
- *as to the applicant's entitlement to claim the priority of the earlier application (Rule 4.17(iii))*

**Published:**

- *with international search report (Art. 21(3))*

**METHODS, APPARATUSES, AND SYSTEMS FOR ASPIRATING AIRWAYS****PRIORITY PARAGRAPH**

[0001] This Application claims priority to U.S. Provisional Patent Application serial number 62/747,520 filed October 18, 2018, which is incorporated herein by reference in its  
5 entirety.

**TECHNICAL FIELD**

[0002] The present disclosure relates generally to methods, apparatuses, and systems that assist in the clearing of a patient's airway. More specifically, the present disclosure relates to methods, apparatuses, and systems that assist in aspirating the airway of a patient and where  
10 the apparatus is portable and able to be used with a single hand.

**BACKGROUND**

[0003] Airway injuries, which may result from blunt force and penetrating injuries to the neck and chest, can be life threatening conditions, particularly on a battlefield. The presence of concomitant severe injuries and non-specific symptoms and signs for this type of injury may  
15 delay diagnosis and lead to early fatal outcome due to asphyxiation from airway obstruction or death from tension pneumothorax, or late sequela such as airway stenosis and recurrent pulmonary infections.

[0004] Airway obstruction and compromise is the second leading cause of preventable battlefield death, which can be attributed to the unavailability of sufficiently powerful portable  
20 suction systems, among others factors. Therefore, prompt diagnosis is mandatory for the survival of these patients. However, treatment of these patients is similarly challenging: it includes securing a patient airway that will allow adequate ventilation and then repairing the injury with a smaller impact on the respiratory function and the quality of life of the patient.

[0005] A number of portable suction devices available in the market are either manually  
25 powered and less efficient, or battery powered and bulky/heavy for combat medics to carry in their kits. Examples of portable suction devices include the Laerdal Compact Suction Unit® 4 (LCSU® 4) by Laerdal Medical; the SSCOR Quickdraw® by SSCOR, Inc.; and the Clario Airway Suction Pump by Medela AG.

[0006] The LCSU® 4 includes a collection canister supported by a wire bracket. The collection canister can come in a 300 mL size or an 800 mL size container when extra suction volume is needed. The LCSU® 4 weighs between 3.3 to 4.3 pounds depending on the collection canister size and provides between 50 mmHg to 550 mmHg vacuum pressure for about 45 minutes when powered by batteries. The collection canister must also be correctly oriented to fit into the wire bracket. An air flow rate of 30 L/min can be obtained with the device. The overall dimensions of the LCSU® 4 are 18.5 cm x 26.2 cm x 8.12 cm with a 300 mL canister and 23.6 cm x 19 cm x 23.6 cm with an 800 mL canister.

[0007] The SSCOR Quickdraw® Tactical requires 10 AAA sized batteries to power the device for 60 to 100 minutes. A maximum negative pressure of > 500 mmHg and a low negative pressure setting of 80 mmHg to 100 mmHg can be achieved with the device. The drainable collection canister can hold a maximum of 300 mL. The collection canister must also be correctly oriented. The SSCOR Quickdraw® Tactical weighs 2.6 pounds and has overall dimensions of 27 cm x 11 cm x 11 cm.

[0008] The Clario Airway Suction Pump by Medela AG is intended for home health use and can operate for about 50 minutes when powered using the rechargeable battery. A low vacuum setting of 135 mmHg, a medium vacuum setting of 270 mmHg, and a maximum vacuum setting of 600 mmHg can be achieved with the device. The collection canister can hold a maximum of 550 mL and must also be correctly oriented during operation. A fluid flow rate of 15 L/min can be obtained with the device. The Clario Airway Suction Pump weighs about 2.0 kilograms and has overall dimensions of 22.3 cm x 25.5 cm x 9.5 cm.

[0009] Market assessments and surveys conducted by the inventors have demonstrated that combat medics require a lightweight, compact, efficient, and reliable portable suction alternative for the battlefield because combat medics are required to carry everything on their backs. Similarly, civilian EMS providers need a lightweight, reliable, and effective means of clearing debris such as saliva and vomitus from the airway of critical patients. Thus, portability, effectiveness, and ruggedness are key attributes for an airway suction device.

[0010] Currently, such a device does not exist. Current designs are over twenty years old and fall short on many aspects because they were developed using poor/outdated technology. The designs are typically heavy, bulky, provide inadequate suction, and have a short battery life. This results in unnecessary patient suffering and can lead to death from suffocation due

to inadequate aspiration of debris or the inability to gain control of the patient's airway in a timely manner.

[0011] In view of the foregoing, it is apparent that there exists a need for a device and method to clear airways of patients that overcomes, mitigates, or solves the above problems in the art. Embodiments described herein fulfill this and other needs in the art, which will become apparent to the skilled artisan once given the following disclosure.

### SUMMARY

[0012] This disclosure includes implementations of methods and configurations of apparatuses and systems for aspirating the airway of a patient. Non-limiting examples of conditions that benefit from this disclosure include, but are not limited to, tracheobronchial injuries, asphyxiation from airway obstruction, and tension pneumothorax.

[0013] Certain embodiments are directed to an apparatus for aspirating an airway of a patient, the apparatus comprising: a main body comprising: a pressure sensor; a controller in communication with the pressure sensor, the controller comprising a processor, a centrifugal pump, and a memory; a power source in communication with the controller; a storage canister housing coupled to the main body, the storage canister housing comprising a first end coupled to the main body, a second end having a weighted portion and configured to be coupled to the first end to permit free rotation, such that the second end gravitationally rotates about a first longitudinal axis, an inlet disposed on the second end, where the inlet is configured to rotate about a second longitudinal axis that is offset by a distance from the first longitudinal axis; a storage canister disposed within the storage canister housing and coupled to the inlet of the storage canister housing; a suction tube having a proximal end coupled to the inlet and a distal end; and a handle coupled to the distal end of the suction tube, the handle comprising a first portion having an opening configured to receive a suction catheter, and a second portion moveably coupled to the first portion and configured to receive the distal end of the suction tube. The apparatus can further include a filter disposed within the opening of the first portion. In certain aspects, the apparatus of any embodiment described herein can be configured to include the first portion having a slot for receiving a release mechanism for detaching the second portion from the first portion. The controller can be configured to measure a pressure at the inlet and shut off the pump when the measured pressure falls below a threshold pressure. The apparatus of any embodiment described herein can further include a light source coupled to the handle. In certain aspects, the apparatus of any embodiment described herein can further

include an outer cover configured to be coupled to the main body and enclose a portion of the storage canister housing. In certain aspects, the storage canister is configured to be at least partially collapsible, and in some instance fully collapsible. In certain aspects, filter(s) can be position at one or both ends of the canister to protect the pump from solid and viscous particles during suction and changes in orientation (see FIG. 17 for an example). The interior walls of the canister can be modified or coated, for example the interior wall of the canister can be coated, completely or partially with super absorbent polymers, pH reagents, and/or oxygen-sensitive luminescent materials that will assist with demobilizing fluid contents located inside for evacuation from device and assist with content characterization. Certain embodiments can include design elements that provide for characterization of fluid content, these elements include but are not limited to (i) a separate sample chamber couple to the canister, wither upstream or downstream with respect to the canister; (ii) sensors that measure metrics that help identify fluid sources, such as pH or blood oxygenation, this allows for determination if accumulated fluids include arterial blood (indicating a dangerous hemorrhage), vomit, or other components that may dictate clinical response; (iii) a multi-lumen tubing can be utilized to provide a conduit for wiring, etc. and/or (iv) a "periscope-like" orifice in the housing located over the canister for assisted viewing of canister content. In certain aspects, a suction device tubing with multi lumen tubing can include a suction catheter equipped with additional features without becoming large and bulky, the features include, but are not limited to (i) fiber optic cables inserted through a small channel of the tubing - eliminating the need for an LED, switch and a battery to be embedded into the catheter; and/or (ii) electrical controls and/or connections for the operation of the suction tip, this may also allow for small data lines to be passed through the small channel to transmit information to a CPU within the pump housing.

**[0014]** The centrifugal pump can be configured to generate a vacuum pressure of at least or about 400, 500, 600, 700, to 800 mmHg, including all values and ranges there between. The controller can be configured to evacuate water, vomitus, solid pieces, solid particulates, and/or blood at a flow rate of at least or about 0.5, 0.75, 1.0, 1.25, 1.5, 2.0, 3.0, 4.0, 5.0 to 10 L/min, including all values and ranges there between. The storage canister can have a storage volume of at least 0.2, 0.5, 1.0, 1.5, 2.0 L to 3.0 L. The processor can be configured to determine a patient condition via optical and/or electrochemical analysis. The main body, storage canister housing, and/or outer cover includes a surface coating selected from the group of surface coating characteristics consisting of: anti-reflective, camouflage, electromagnetic shielding, and combinations thereof. The apparatus of any embodiment described herein can further

include a muffler system coupled to the main body to reduce operating noise. The storage canister can have a fixed volume portion capable of holding up to 200, 300, 400, 500, 600, 700, 800, 900 mL or more, and an expandable volume portion capable of holding at least an additional 100, 200, 300, 400, 500 mL to 3000 mL or greater. The apparatus of any embodiment described herein can further include a suction tip attachment configured to be coupled to the suction catheter, where the suction tip attachment includes a filter for trapping debris. The controller can be configured to provide a pressure range for treating pneumothorax (*e.g.*, 5 to 20 mmHg). The apparatus of any embodiment described herein can where the apparatus has an overall dimension of 15 cm x 7.5 cm x 7.5 cm to 30 cm x 15 cm x 15 cm. In certain instances the overall dimension is at most 30 cm x 15 cm x 15 cm. The apparatus of any embodiment described herein can have an overall weight of less than 0.5, 1.0, or 1.2 kg. The handle can further include a trigger mechanism configured to actuate the centrifugal pump. In certain aspects, the handle can include a lumen in fluid communication with an irrigation chamber and the controller configured to dispense fluid from the irrigation container through the lumen. The apparatus of any embodiment described herein can include a handle having a camera.

**[0015]** Certain embodiments are directed to an apparatus for aspirating an airway of a patient, the apparatus comprising a main body comprising, a pressure sensor, a controller in communication with the pressure sensor, the controller comprising: a processor, a centrifugal pump, and a memory; a power source in communication with the controller; a storage canister housing coupled to the main body, the storage canister housing comprising: a first end coupled to the main body, a second end having a weighted portion and configured to be coupled to the first end to permit free rotation, such that the second end gravitationally rotates about a first longitudinal axis, an inlet disposed on the second end, where the inlet is configured to rotate about a second longitudinal axis that is offset by a distance from the first longitudinal axis; a storage canister disposed within the storage canister housing and coupled to the inlet of the storage canister housing, the storage canister comprising: a first portion having a plurality of ribs defining a fixed volume; a second portion coupled to the first portion and defining a second volume; and a suction tube having a proximal end coupled to the inlet and a distal end; and a handle coupled to the distal end of the suction tube, the handle comprising: a first portion having an opening configured to receive a suction catheter; and a second portion moveably coupled to the first portion and configured to receive the distal end of the suction tube. The apparatus of embodiments described herein can further comprising a filter disposed within the

opening of the first portion. The first portion can include a slot for receiving a release mechanism for detaching the second portion from the first portion. The controller can be configured to measure a pressure at the inlet and shut off the pump when the measured pressure falls below a threshold pressure, *e.g.*, a drop in of 50%. The apparatus of any embodiment described herein can further include a light source coupled to the handle. In certain aspects, the apparatus of any embodiment described herein can include an outer cover configured to be coupled to the main body and enclose a portion of the storage canister housing. The storage canister is configured to be at least partially collapsible, and in some instances fully collapsible. The apparatus of any embodiment described herein can where the centrifugal pump is configured to generate a vacuum pressure of at least 500, 600, 700, to 800 mmHg, including all values and ranges there between. The apparatus of any embodiment described herein can where the controller is configured to evacuate water, vomitus, and/or blood at a flow rate of at least 1.0, 1.25, 1.5, 2.0, 3.0, 4.0, 5.0 to 10 L/min, including all values and ranges there between. The storage canister can have a storage volume of at least 0.5 L. The storage volume can be 0.5, 1.0, 1.5, 2.0 L to 3.0 L or more. The processor can be configured to determine a patient condition via optical and/or electrochemical analysis. The main body, storage canister housing, and/or outer cover includes a surface coating selected from the group of surface coating characteristics consisting of: anti-reflective, camouflage, electromagnetic shielding, and combinations thereof. The apparatus of any embodiment described herein can further include a muffler system coupled to the main body to reduce operating noise. In certain aspects, the fixed volume of the first portion is at least 200, 300, 400, 500, 600, 700, 800, 900 mL or more, and an expandable volume portion capable of holding at least an additional 800, 900, 1000, 1100, 1500 mL, 2000 m, to 3000 mL or more. The apparatus of any embodiment described herein can further comprising a suction tip attachment configured to be coupled to the suction tip, where the suction tip attachment includes a filter for trapping debris. The controller can be configured to provide a pressure range for treating pneumothorax (*e.g.*, 5 to 20 mmHg). The apparatus of any embodiment described herein can where the apparatus has an overall dimension of 15 cm x 7.5 cm x 7.5 cm to 30 cm x 15 cm x 15 cm. In certain instances the overall dimension is at most 30 cm x 15 cm x 15 cm. The apparatus of any embodiment described herein can weigh 0.5, 1.0, to 1.2 kg. In certain instances the apparatus weight is less than 1.2 kg. The apparatus of any embodiment described herein can where the handle further comprises a trigger mechanism configured to actuate the centrifugal pump. The handle can include or form a lumen in fluid communication with an irrigation chamber and the controller

configured to dispense fluid from the irrigation container through the lumen. The handle can include a camera.

[0016] Certain embodiments are directed to methods for aspirating an airway of a patient, the method comprising: (a) providing any one of the apparatus described herein; (b) inserting  
5 the suction tube into the airway of the patient; (c) aspirating a fluid from the airway using any one of the apparatus described herein. The method can further include (e) detecting a patient condition via optical and/or electrochemical analysis using any one of the apparatus described herein.

[0017] The term “coupled” is defined as connected, although not necessarily directly, and  
10 not necessarily mechanically; two items that are “coupled” may be unitary with each other.

[0018] The terms “a” and “an” are defined as one or more unless this disclosure explicitly requires otherwise.

[0019] The term “substantially” is defined as largely but not necessarily wholly what is specified (and includes what is specified; e.g., substantially 90 degrees includes 90 degrees and  
15 substantially parallel includes parallel), as understood by a person of ordinary skill in the art. In any configuration or implementation of the present devices, apparatuses, kits, and methods, the term “substantially” may be substituted with “within [a percentage] of” what is specified, where the percentage includes 0.1, 1, 5, and/or 10 percent.

[0020] The terms “comprise” (and any form of comprise, such as “comprises” and  
20 “comprising”), “have” (and any form of have, such as “has” and “having”), “include” (and any form of include, such as “includes” and “including”) and “contain” (and any form of contain, such as “contains” and “containing”) are open-ended linking verbs. As a result, an apparatus, device, or kit that “comprises,” “has,” “includes” or “contains” one or more elements possesses those one or more elements, but is not limited to possessing only those elements. Likewise, a  
25 method that “comprises,” “has,” “includes” or “contains” one or more steps possesses those one or more steps, but is not limited to possessing only those one or more steps.

[0021] Further, an apparatus, device, or structure that is configured in a certain way is configured in at least that way, but it can also be configured in other ways than those specifically described.

[0022] Any configuration or implementation of any of the present devices, apparatuses, kits, and methods can consist of or consist essentially of – rather than comprise/include/contain/have – any of the described steps, elements, and/or features. Thus, in any of the claims, the term “consisting of” or “consisting essentially of” can be substituted  
5 for any of the open-ended linking verbs recited above, in order to change the scope of a given claim from what it would otherwise be using the open-ended linking verb.

[0023] Details associated with the configurations described above and others are presented below.

### BRIEF DESCRIPTION OF THE DRAWINGS

10 [0024] The following drawings illustrate by way of example and not limitation. For the sake of brevity and clarity, every feature of a given structure is not always labeled in every figure in which that structure appears. Identical reference numbers do not necessarily indicate an identical structure. Rather, the same reference number may be used to indicate a similar feature or a feature with similar functionality, as may non-identical reference numbers. The  
15 figures are drawn to scale (unless otherwise noted), meaning the sizes of the depicted elements are accurate relative to each other for at least the configurations depicted in the figures.

[0025] FIG. 1 shows an exploded view of an exemplary configuration of the present apparatus for aspirating an airway of a patient.

20 [0026] FIG. 2 shows a perspective view of a configuration of the present apparatus for aspirating an airway of a patient.

[0027] FIG. 3 shows a perspective view of a configuration of the storage canister housing coupled to the main body.

[0028] FIG. 4A shows an inlet end view of a configuration of the storage canister housing with the inlet in a first position.

25 [0029] FIG. 4B shows the inlet end view of FIG. 4A with the inlet in a second position.

[0030] FIG. 5 shows a perspective view of an outer cover of the storage canister housing.

[0031] FIG. 6 shows a side view of FIG. 3 with an outer cover positioned to cover the storage canister housing.

- [0032] FIG. 7 shows a perspective view of the outer cover of FIG. 5 coupled to the main body.
- [0033] FIG. 8 shows a perspective view of an exemplary configuration of a storage container.
- 5 [0034] FIG. 9 shows the storage container of FIG. 8 in a collapsed state.
- [0035] FIG. 10 shows a perspective view of a second configuration of a storage container.
- [0036] FIG. 11 shows a perspective view of a third configuration of a storage container.
- [0037] FIG. 12 shows a perspective view of a fourth configuration of a storage container.
- [0038] FIG. 13A shows a perspective view of a first configuration of a handle in a closed  
10 position with a key inserted into a release slot.
- [0039] FIG. 13B shows a perspective view of the handle of FIG. 13A in an open position.
- [0040] FIG. 13C shows an exploded perspective view of a second configuration of a handle.
- [0041] FIG. 14A shows a perspective view of a second configuration of a handle in a  
15 closed position and coupled to a suction catheter.
- [0042] FIG. 14B shows a perspective view of the handle of FIG. 14A in an open position and coupled to a suction catheter.
- [0043] FIG. 15 shows a perspective view of a third configuration of a handle coupled to a light source.
- 20 [0044] FIG. 16 shows a side view of a fourth configuration of the handle in an open position and coupled to a light source.
- [0045] FIG. 17 shows an example of a canister comprising a filter at both ends.
- [0046] FIG. 18 shows one example of a device that is a shock resistant, low profile, noise dampening portable suction device.

## DESCRIPTION OF ILLUSTRATIVE EMBODIMENTS

[0047] Referring now to the drawings, and more particularly to FIGs. 1-2, in some configurations an apparatus 100 for aspirating an airway of a patient includes a main body 104 having a pump 108 (*e.g.*, centrifugal pump) and a storage canister housing 112 coupled to the main body 104. In some configurations, the pump 108 is configured to generate a vacuum pressure of at least 400 mmHg. The main body 104 can include a pressure sensor 116, a controller 120 in communication with the pressure sensor 116 and having a processor 124 and a memory 128, and a power source 132 in communication with controller 120. As shown in FIGs. 3 and 4A-4B, the storage canister housing 112 can include a first end 136 coupled to the main body 104, and a second end 140 having a weighted portion 144 and configured to be coupled to the first end 136 to permit free rotation, such that the second end 140 gravitationally rotates about a first longitudinal axis 148. In some configurations, the first end 136 can be coupled to the second end 140 with one or more sets of ball bearings to permit free rotation. An inlet 152 is disposed on the second end 140 and can be configured to rotate about a second longitudinal axis 156 that is offset by a distance 160 from the first longitudinal axis 148. In this way, an eccentric center of rotation 164 (with the center of rotation being along the inlet/outlet axis 156) permits the weighted portion 144 to orient the storage canister housing 112 using gravity such that the inlet 152 will move from a first position (as shown in FIG. 4A, inlet 152 is positioned below plane A-A bisecting storage canister housing 112) to a second position (as shown in FIG. 4B, inlet 152 has moved above plane A-A bisecting storage canister housing 112) when the apparatus 100 is placed on any one of its sides (*e.g.*, 168a, 168b, 168c, 168d).

[0048] As shown in FIGs. 3 and 4A-4B, storage canister housing 112 is cylindrical in shape, but can include other shapes configured to have an eccentric center of rotation with respect to the inlet. A storage canister (*e.g.* 172a, 172b, 172c, 172d) of in FIGs. 8-12, is disposed within the storage canister housing 112 and coupled to the inlet 152 of the storage canister housing 112. A suction tube 176 can be coupled to the inlet 152 and configured to receive a handle (*e.g.*, 180a, 180b, 180c, 180d) that can be coupled to a suction catheter 184. In some configurations, a suction tip attachment (not shown) can be configured to be coupled to a distal end of the suction catheter 184, where the suction tip attachment includes a filter for trapping debris. In some configurations, such as the ones shown in FIGs. 2, 6 and 7, an outer cover 188 (as best shown in FIG. 5) can be configured to be coupled to the main body 104 and enclose a portion of the storage canister housing 112. As shown in FIG. 6, the outer cover 188

is aligned with the main body 104, and then placed over the storage canister housing 112 and coupled to the main body 104 to enclose a portion of the storage canister housing 112, as shown in FIG. 7.

5 [0049] In some configurations, the controller 120 is configured to measure a pressure at the inlet 152 and shut off the pump 108 when the measured pressure falls below a threshold pressure. In some configurations, the controller 120 is configured to evacuate water, vomitus, solid pieces, solid particulates, and/or blood at a flow rate of at least 0.5 L/min. In some configurations, the controller 120 is configured to provide a pressure range for treating pneumothorax. In some configurations, the processor 124 is configured to determine a patient  
10 condition via optical and/or electrochemical analysis.

[0050] As shown in FIGs. 8-12, in some configurations the storage canister (*e.g.*, 172a, 172b, 172c, 172d) is configured to be at least partially collapsible. In this way, the overall dimensions of the apparatus can be minimized while providing the ability to hold sufficient fluid volume as needed. As shown in FIG. 8, in some configurations the storage canister 172a  
15 can include a first portion 192 having a plurality of ribs 196 defining a fixed volume and a second portion 200 coupled to the first portion 192 and defining a second volume. As shown in FIG. 9, the second portion 200 can collapse to be at least partially contained within the first portion 192 when not in use. In some configurations, the storage canister 172a has a total storage volume of at least 0.2 L. In some configurations, the storage canister 172a has a fixed  
20 volume portion capable of holding up to 200 mL, and an expandable second volume portion capable of holding at least an additional 100 mL. In some configurations, such as the one shown in FIG. 10, the storage canister 172b can include an internal spring coil 204 configured to gradually expand the storage canister 172b as fluid fills the storage canister 172b. In some configurations, such as the one shown in FIG. 11, the storage canister 172c can include a male  
25 end 208 configured to receive a female end (not shown). In some configurations, such as the one shown in FIG. 12, the male end 208 of storage canister 172d can be threaded.

[0051] As shown in FIGs. 13A-13B, in some configurations the aspirating apparatus includes a handle (*e.g.*, 180a, 180b, 180c, 180d) having a first portion 212 that has an opening  
30 216 configured to receive a suction catheter 184; and a second portion 220 moveably coupled to the first portion 212 and configured to receive the distal end of the suction tube 176. In some configurations, a filter is disposed within the opening 216 of the first portion 212 of the handle 180a. In some configurations, the first portion 212 includes a slot 224 for receiving a release

mechanism (*e.g.*, key 228) for decoupling the second portion 220 from the first portion 212. As best shown in FIG. 13A, when key 228 is inserted into the slot 224, the internal locking mechanism is disengaged to permit the second portion 220 to rotate from a closed position (as shown in FIGs. 13A and 14A) to an open position as shown in FIGs. 13B, 13C, and 14B. In this way, debris that gets trapped can be quickly removed and the handle 180a can be closed to resume suction. In some configurations, such as the one shown in FIG. 13C, the handle 180b can include two or more portions (*e.g.*, 232a, 232b, 232c) that can be coupled together to form handle 180b. In this way, the handle 180b can be decoupled to remove larger pieces of debris and/or to more easily clean the handle 180b. In some configurations, such as the ones shown in FIGs. 15-16, a light source 236 can be coupled to the handle (*e.g.*, 180c, 180d). As shown in FIG. 16, the handle 180d includes a first portion 240 coupled to the second portion 244 via a break-action type hinge 248. In some configurations, the handle includes a trigger mechanism configured to actuate the centrifugal pump. In some configurations, the handle includes a lumen in fluid communication with an irrigation chamber and the controller configured to dispense fluid from the irrigation container through the lumen. In some configurations, the handle includes an integrated camera.

**[0052]** In some configurations, the main body 104, storage canister housing 112, and/or outer cover 188 includes a surface coating selected from the group of surface coating characteristics consisting of: anti-reflective, camouflage, electromagnetic shielding, and combinations thereof.

**[0053]** In some configurations, a muffler system can be coupled to the main body to reduce operating noise.

**[0054]** In some configurations, the apparatus has an overall dimension of 30 cm x 15 cm x 15 cm or less. In some configurations, the apparatus has an overall weight of less than 1.2 kg.

**[0055]** In some implementations, a method for aspirating an airway of a patient includes (a) providing any one of the present apparatuses; (b) inserting the suction tube into the airway of the patient; (c) aspirating a fluid from the airway using any one of the present apparatuses. In some implementations, the method further includes detecting a patient condition via optical and/or electrochemical analysis using any one of the present apparatuses.

**[0056]** The above specification and examples provide a complete description of the structure and use of exemplary configurations. Although certain configurations have been

described above with a certain degree of particularity, or with reference to one or more individual configurations, those skilled in the art could make numerous alterations to the disclosed configurations without departing from the scope of this invention. As such, the various illustrative configurations of the present devices, apparatuses, kits, and methods are not intended to be limited to the particular forms disclosed. Rather, they include all modifications and alternatives falling within the scope of the claims, and configurations other than the one shown may include some or all of the features of the depicted configuration. For example, components may be combined as a unitary structure, and/or connections may be substituted. Further, where appropriate, aspects of any of the examples described above may be combined with aspects of any of the other examples described to form further examples having comparable or different properties and addressing the same or different problems. Similarly, it will be understood that the benefits and advantages described above may relate to one configuration or may relate to several configurations.

**[0057]** The claims are not intended to include, and should not be interpreted to include, means-plus- or step-plus-function limitations, unless such a limitation is explicitly recited in a given claim using the phrase(s) “means for” or “step for,” respectively.

## REFERENCES

The following references, to the extent that they provide exemplary procedural or other details supplementary to those set forth herein, are specifically incorporated herein by reference.

1. C. Prokakis, et al. "Airway trauma: A review on epidemiology, mechanisms of injury, diagnosis and treatment" *Journal of Cardiothoracic Surgery*, 9(1):117, 2014.
2. Eastridge, B.J., et al, "Death on the battlefield (2001-2011): Implications for the future of combat casualty care" *J Trauma & Acute Care Surg*, 73(6), S431-S437, 2012.
3. Peake JB. "Beyond the Purple Heart: continuity of care for the wounded in Iraq" *N Engl J Med*, 352(3):219-222, 2005.
4. Champion HR, et al, "A profile of combat injury". *J Trauma*, 54(5):S13-S19, 2003.
5. A.T. Simpson. "Transporting Lazarus: Physicians, the state, and the creation of the modern paramedic and ambulance 1955-73." *J History of Medicine & Allied Sciences*, 2013.
6. Calkins, M. D. "Evaluation of possible battlefield suction pumps for the far-forward setting." *Military medicine*, 167(10): 803, 2002.

## CLAIMS

1. An apparatus for aspirating an airway of a patient, the apparatus comprising:
  - a main body comprising:
    - a pressure sensor;
    - a controller in communication with the pressure sensor, the controller comprising:
      - a processor;
      - a centrifugal pump; and
      - a memory;
    - a power source in communication with the controller;
  - a storage canister housing coupled to the main body, the storage canister housing comprising:
    - a first end coupled to the main body;
    - a second end having a weighted portion and configured to be coupled to the first end to permit free rotation, such that the second end gravitationally rotates about a first longitudinal axis;
    - an inlet disposed on the second end, where the inlet is configured to rotate about a second longitudinal axis that is offset by a distance from the first longitudinal axis;
  - a storage canister disposed within the storage canister housing and coupled to the inlet of the storage canister housing;
  - a suction tube having a proximal end coupled to the inlet and a distal end; and
  - a handle coupled to the distal end of the suction tube, the handle comprising:
    - a first portion having an opening configured to receive a suction catheter; and
    - a second portion moveably coupled to the first portion and configured to receive the distal end of the suction tube.
2. The apparatus of claim 1, further comprising a filter disposed within the opening of the first portion.
3. The apparatus of any one of claims 1 to 2, where the first portion includes a slot for receiving a release mechanism for detaching the second portion from the first portion.

4. The apparatus of any one of claims 1 to 3, where the controller is configured to measure a pressure at the inlet and shut off the pump when the measured pressure falls below a threshold pressure.
5. The apparatus of any one of claims 1 to 4, further comprising a light source coupled to the handle.
6. The apparatus of any one of claims 1 to 5, further comprising an outer cover configured to be coupled to the main body and enclose a portion of the storage canister housing.
7. The apparatus of any one of claims 1 to 6, where the storage canister is configured to be at least partially collapsible.
8. The apparatus of any one of claims 1 to 7, where the centrifugal pump is configured to generate a vacuum pressure of at least 400 mmHg.
9. The apparatus of any one of claims 1 to 8, where the controller is configured to evacuate water, vomitus, solid pieces, solid particulates, and/or blood at a flow rate of at least 0.5 L/min.
10. The apparatus of any one of claims 1 to 9, where the storage canister has a storage volume of at least 0.2 L.
11. The apparatus of any one of claims 1 to 10, where the processor is configured to determine a patient condition via optical and/or electrochemical analysis.
12. The apparatus of any one of claims 1 to 11, where the main body, storage canister housing, and/or outer cover includes a surface coating selected from the group of surface coating characteristics consisting of: anti-reflective, camouflage, electromagnetic shielding, and combinations thereof.
13. The apparatus of any one of claims 1 to 12, further comprising a muffler system coupled to the main body to reduce operating noise.

14. The apparatus of any one of claims 1 to 13, where the storage canister has a fixed volume portion capable of holding up to 200 mL, and an expandable volume portion capable of holding at least an additional 100 mL.
15. The apparatus of any one of claims 1 to 14, further comprising a suction tip attachment configured to be coupled to the suction catheter, where the suction tip attachment includes a filter for trapping debris.
16. The apparatus of any one of claims 1 to 15, where the controller is configured to provide a pressure range for treating pneumothorax.
17. The apparatus of any one of claims 1 to 16, where the apparatus has an overall dimension of 30 cm x 15 cm x 15 cm or less.
18. The apparatus of any one of claims 1 to 17, where the apparatus has an overall weight of less than 1.2 kg.
19. The apparatus of any one of claims 1 to 18, where the handle further comprises a trigger mechanism configured to actuate the centrifugal pump.
20. The apparatus of any one of claims 1 to 19, where the handle further comprises a lumen in fluid communication with an irrigation chamber and the controller configured to dispense fluid from the irrigation container through the lumen.
23. The apparatus of any one of claims 1 to 22, where the handle further comprises a camera.
24. An apparatus for aspirating an airway of a patient, the apparatus comprising:
  - a main body comprising:
    - a pressure sensor;
    - a controller in communication with the pressure sensor, the controller comprising:
      - a processor;
      - a centrifugal pump; and
      - a memory;
    - a power source in communication with the controller;

a storage canister housing coupled to the main body, the storage canister housing comprising:

- a first end coupled to the main body;
- a second end having a weighted portion and configured to be coupled to the first end to permit free rotation, such that the second end gravitationally rotates about a first longitudinal axis;
- an inlet disposed on the second end, where the inlet is configured to rotate about a second longitudinal axis that is offset by a distance from the first longitudinal axis;

a storage canister disposed within the storage canister housing and coupled to the inlet of the storage canister housing, the storage canister comprising:

- a first portion having a plurality of ribs defining a fixed volume;
- a second portion coupled to the first portion and defining a second volume; and

a suction tube having a proximal end coupled to the inlet and a distal end; and

a handle coupled to the distal end of the suction tube, the handle comprising:

- a first portion having an opening configured to receive a suction catheter; and
- a second portion moveably coupled to the first portion and configured to receive the distal end of the suction tube.

25. The apparatus of claim 24, further comprising a filter disposed within the opening of the first portion.

26. The apparatus of any one of claims 24 to 25, where the first portion includes a slot for receiving a release mechanism for detaching the second portion from the first portion.

27. The apparatus of any one of claims 24 to 26, where the controller is configured to measure a pressure at the inlet and shut off the pump when the measured pressure falls below a threshold pressure.

28. The apparatus of any one of claims 24 to 27, further comprising a light source coupled to the handle.

29. The apparatus of any one of claims 24 to 28, further comprising an outer cover configured to be coupled to the main body and enclose a portion of the storage canister housing.
30. The apparatus of any one of claims 24 to 29, where the storage canister is configured to be at least partially collapsible.
31. The apparatus of any one of claims 24 to 30, where the centrifugal pump is configured to generate a vacuum pressure of at least 500 mmHg.
32. The apparatus of any one of claims 24 to 31, where the controller is configured to evacuate water, vomitus, and/or blood at a flow rate of at least 1 L/min.
33. The apparatus of any one of claims 24 to 32, where the storage canister has a storage volume of at least 0.5 L.
34. The apparatus of any one of claims 24 to 33, where the processor is configured to determine a patient condition via optical and/or electrochemical analysis.
35. The apparatus of any one of claims 24 to 34, where the main body, storage canister housing, and/or outer cover includes a surface coating selected from the group of surface coating characteristics consisting of: anti-reflective, camouflage, electromagnetic shielding, and combinations thereof.
36. The apparatus of any one of claims 24 to 35, further comprising a muffler system coupled to the main body to reduce operating noise.
37. The apparatus of any one of claims 24 to 36, where the fixed volume of the first portion is at least 200 mL, and the second volume of the second portion is at least 800 mL.
38. The apparatus of any one of claims 24 to 37, further comprising a suction tip attachment configured to be coupled to the suction tip, where the suction tip attachment includes a filter for trapping debris.
39. The apparatus of any one of claims 24 to 38, where the controller is configured to provide a pressure range for treating pneumothorax.

40. The apparatus of any one of claims 24 to 39, where the apparatus has an overall dimension of 30 cm x 15 cm x 15 cm or less.
41. The apparatus of any one of claims 24 to 40, where the apparatus has an overall weight of less than 1.2 kg.
42. The apparatus of any one of claims 24 to 41, where the handle further comprises a trigger mechanism configured to actuate the centrifugal pump.
43. The apparatus of any one of claims 24 to 42, where the handle further comprises a lumen in fluid communication with an irrigation chamber and the controller configured to dispense fluid from the irrigation container through the lumen.
44. The apparatus of any one of claims 24 to 43, where the handle further comprises a camera.
45. A method for aspirating an airway of a patient, the method comprising:
- (a) providing any one of the apparatuses of claims 1 to 44;
  - (b) inserting the suction tube into the airway of the patient;
  - (c) aspirating a fluid from the airway using any one of the apparatuses of claims 1 to 44.
46. The method of claim 45, further comprising:
- (e) detecting a patient condition via optical and/or electrochemical analysis using any one of the apparatuses of claims 1 to 44.

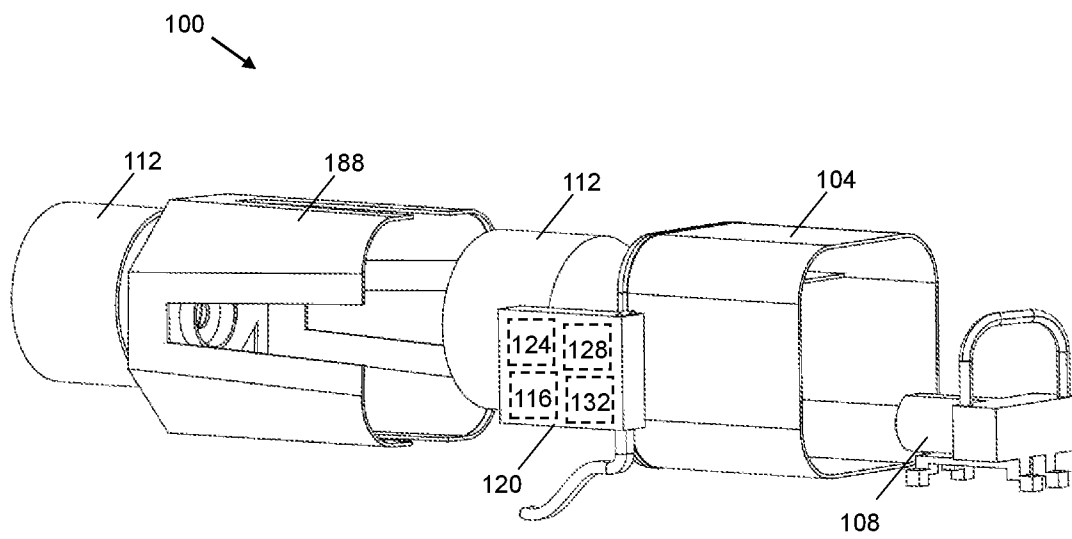

FIG. 1

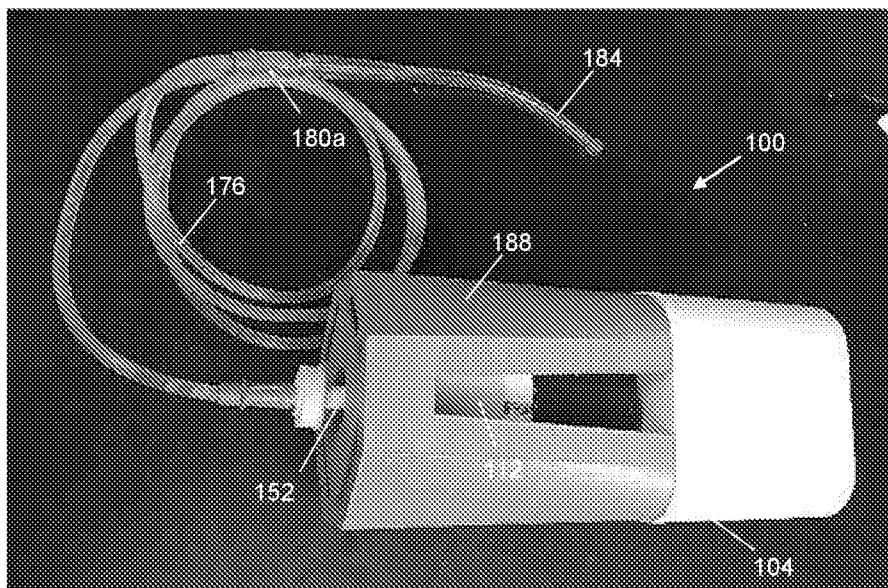

FIG. 2

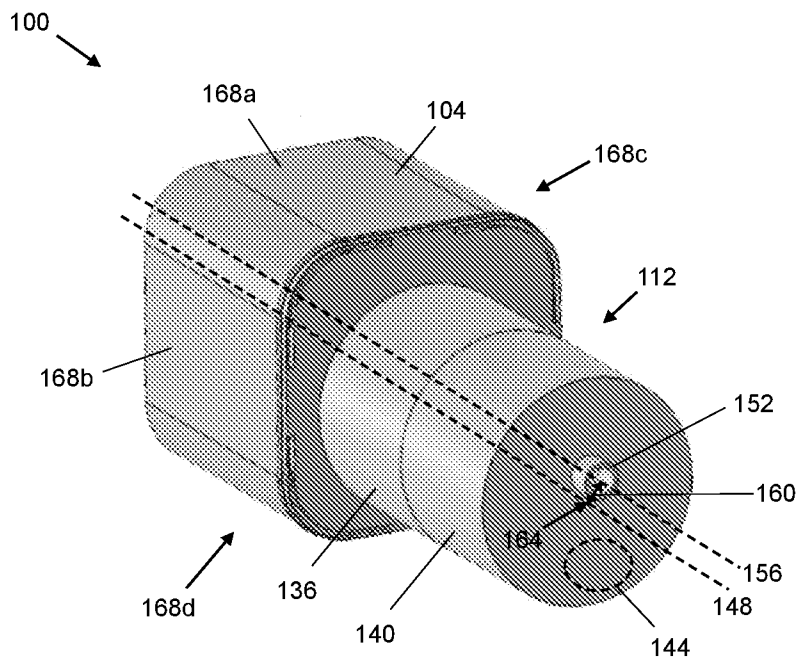
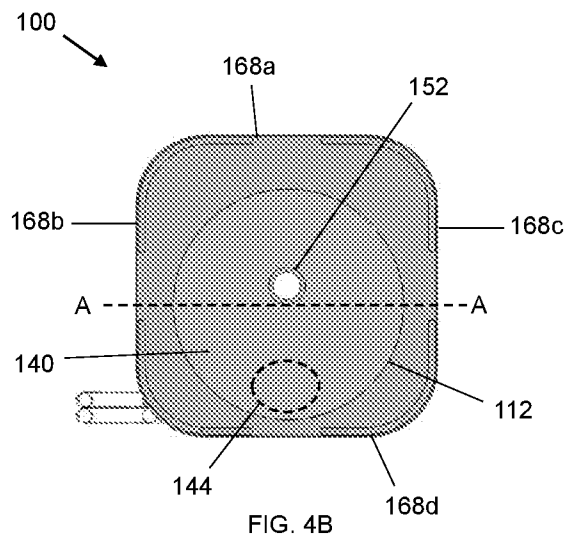
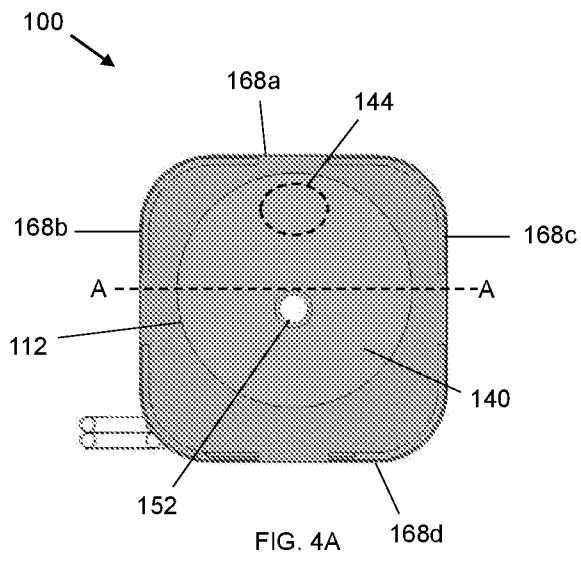

FIG. 3



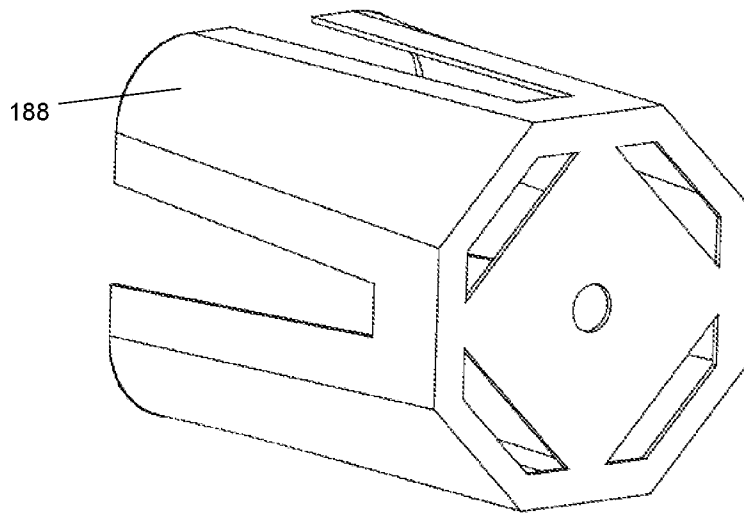

FIG. 5

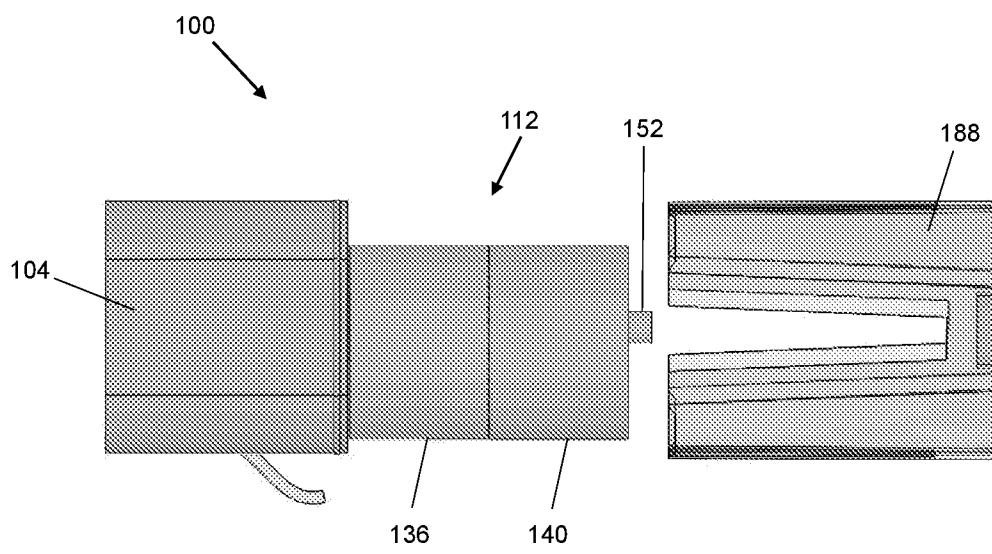

FIG. 6

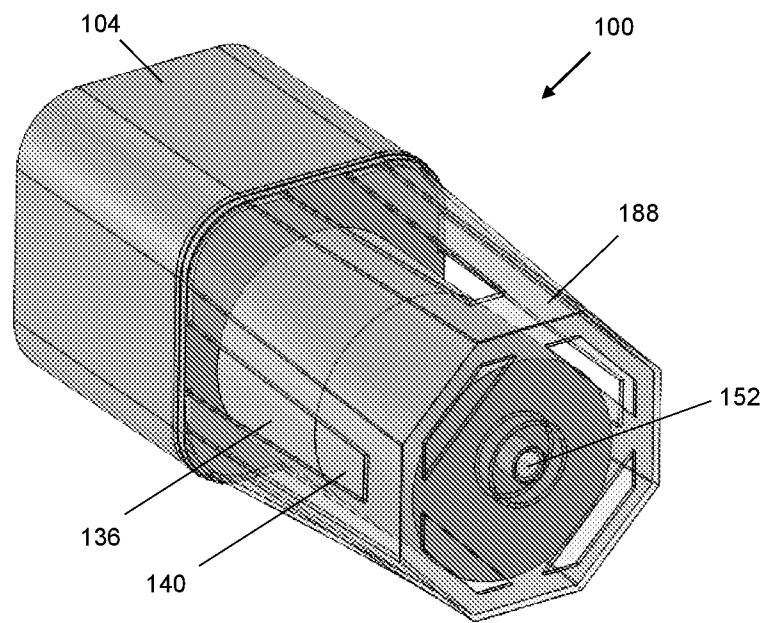

FIG. 7

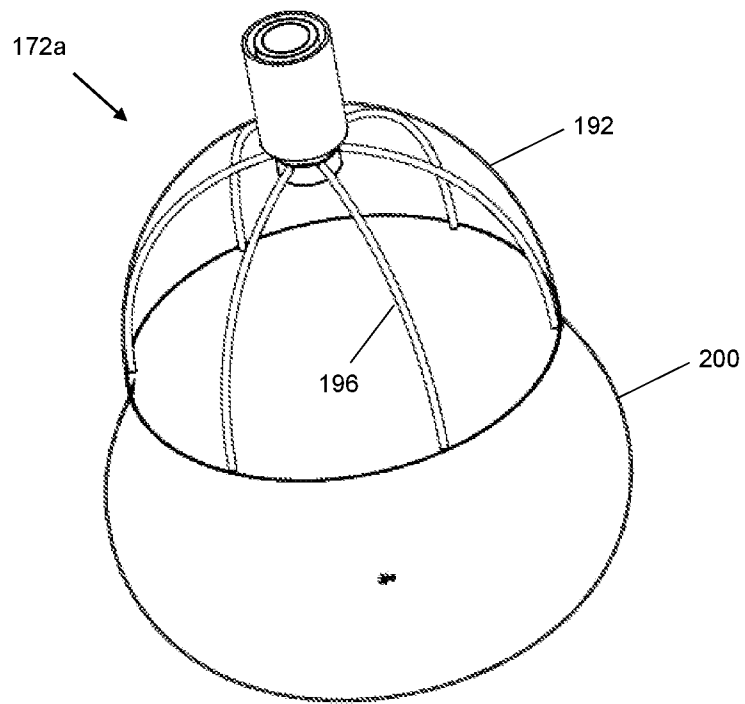

FIG. 8

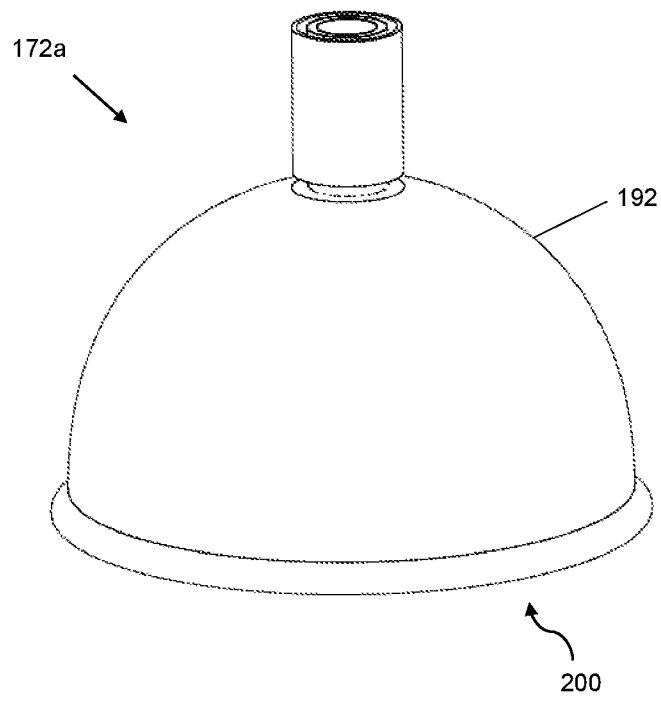

FIG. 9

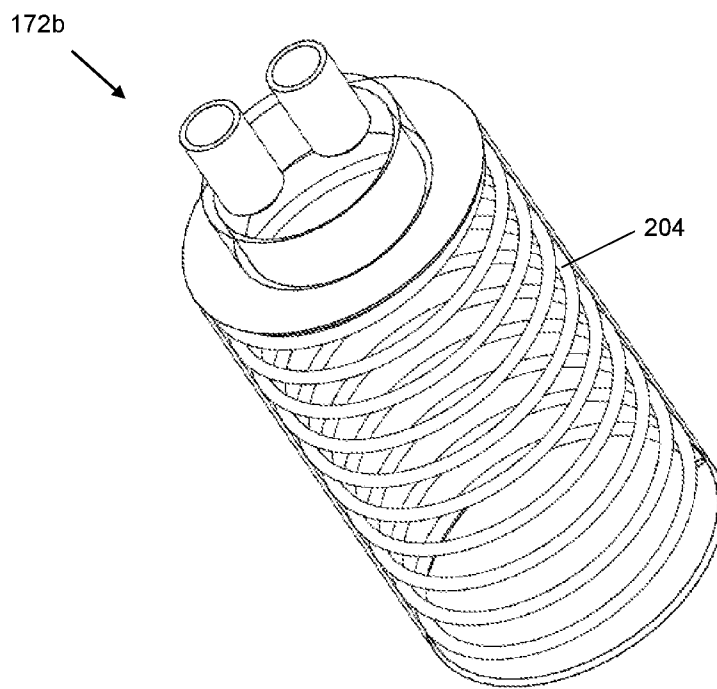

FIG. 10

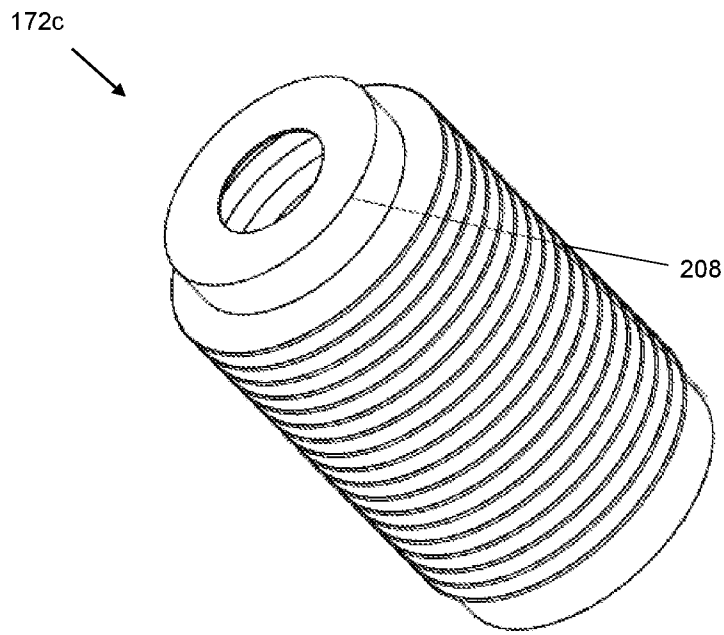

FIG. 11

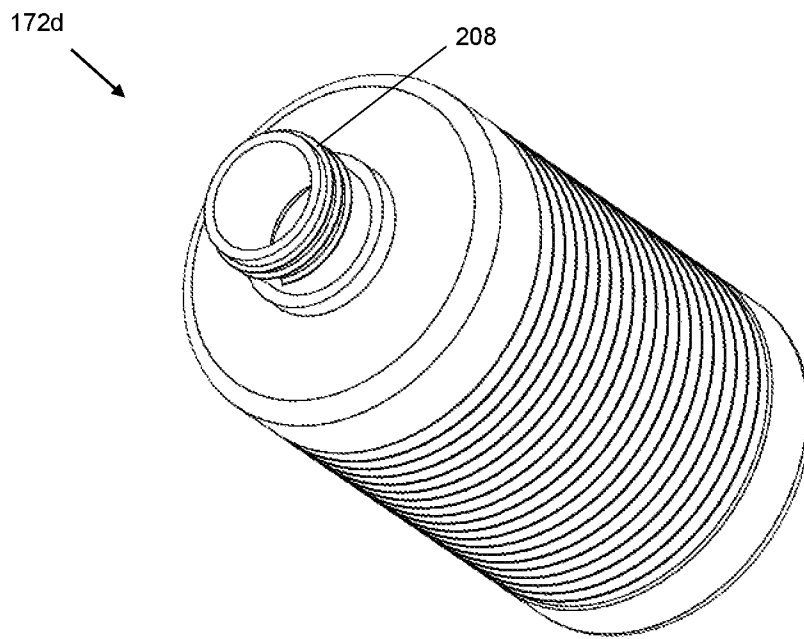

FIG. 12

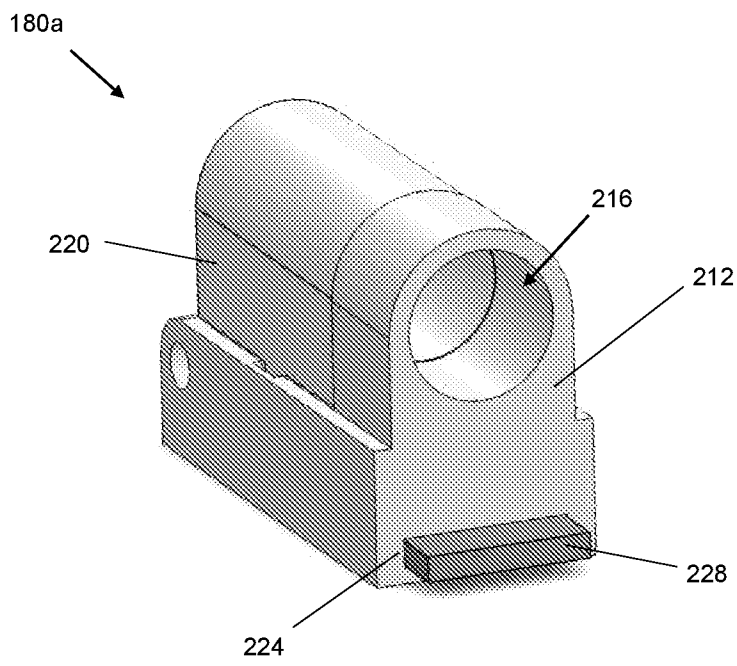

FIG. 13A

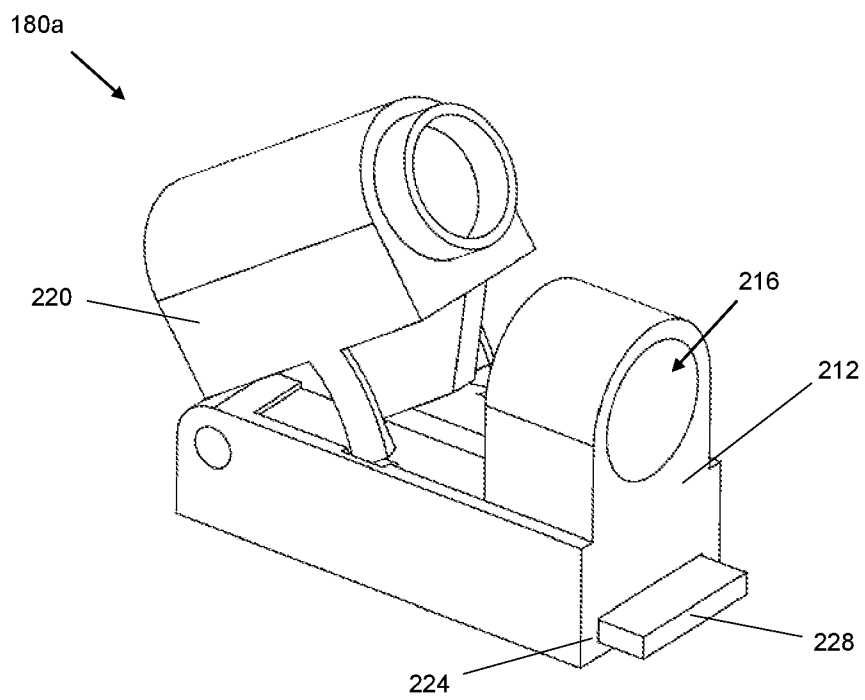

FIG. 13B

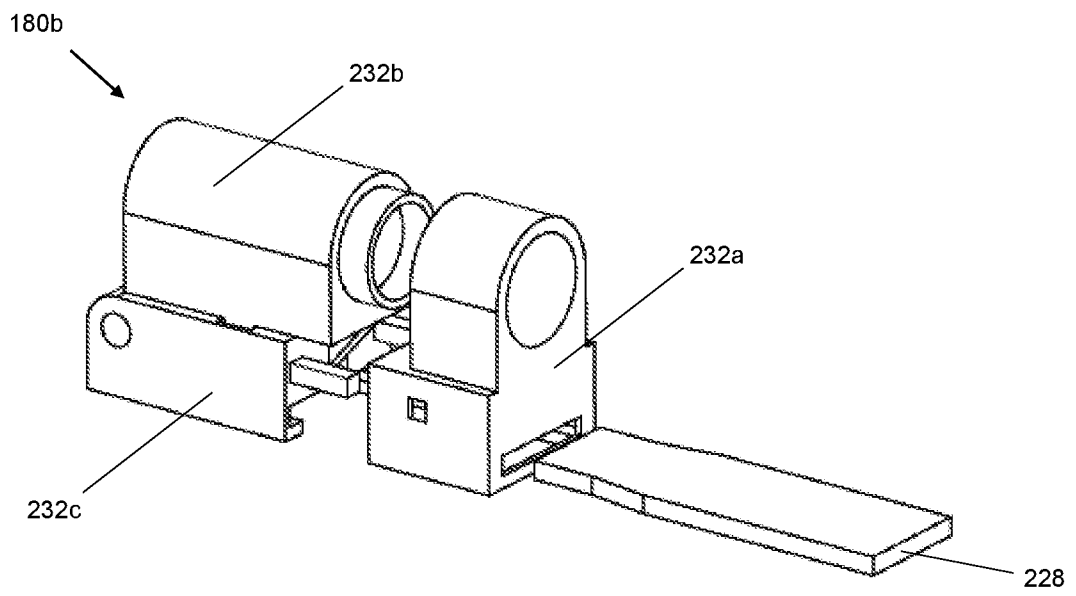

FIG. 13C

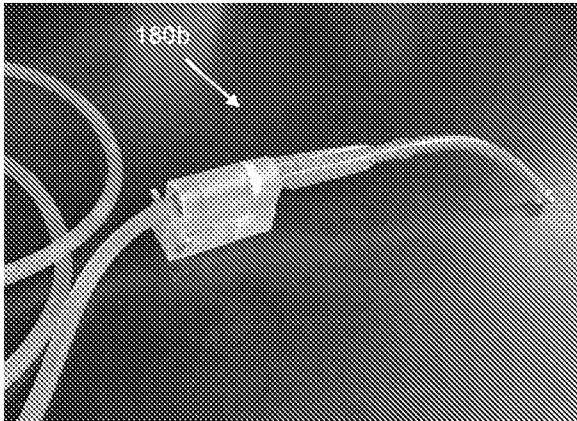

FIG. 14A

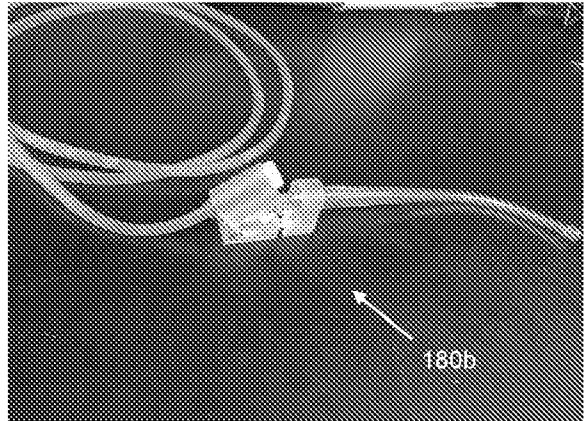

FIG. 14B

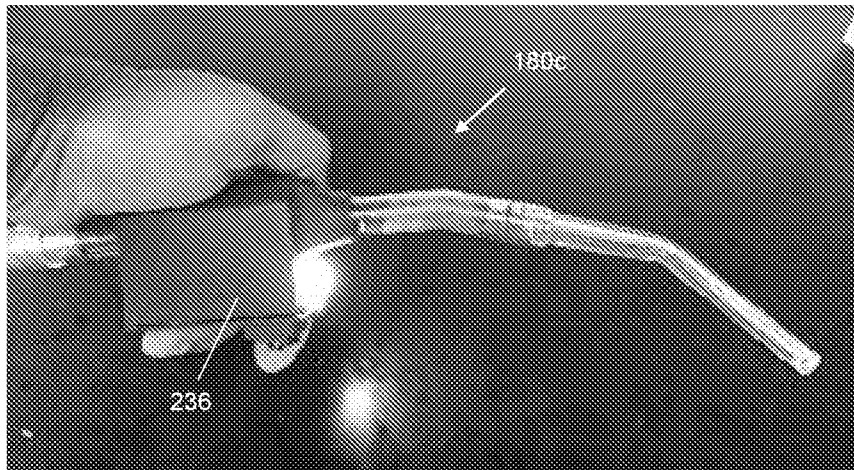

FIG. 15

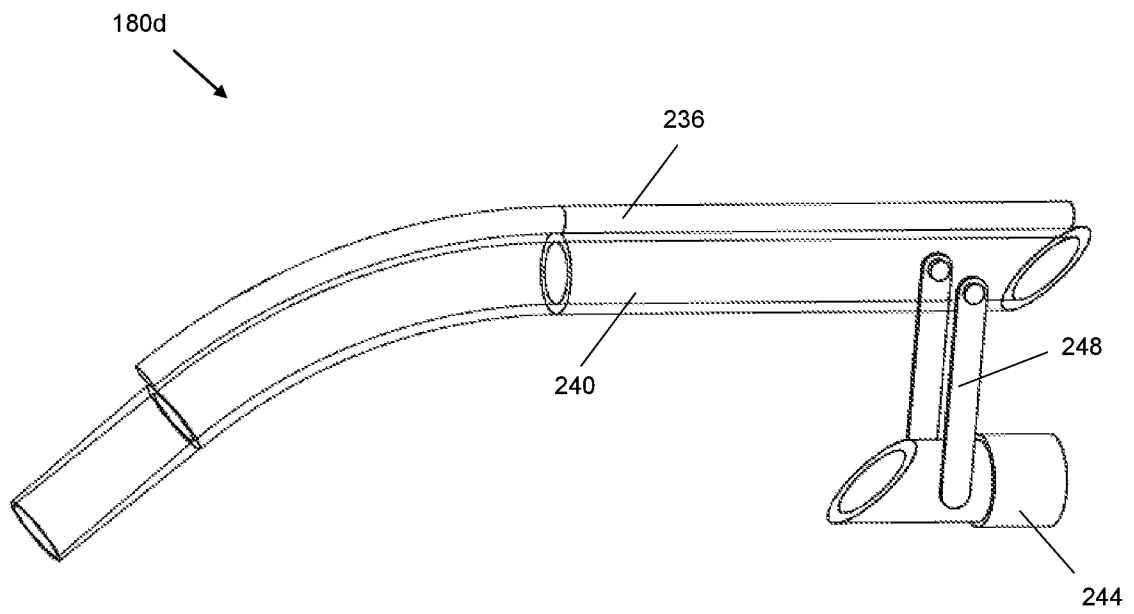

FIG. 16

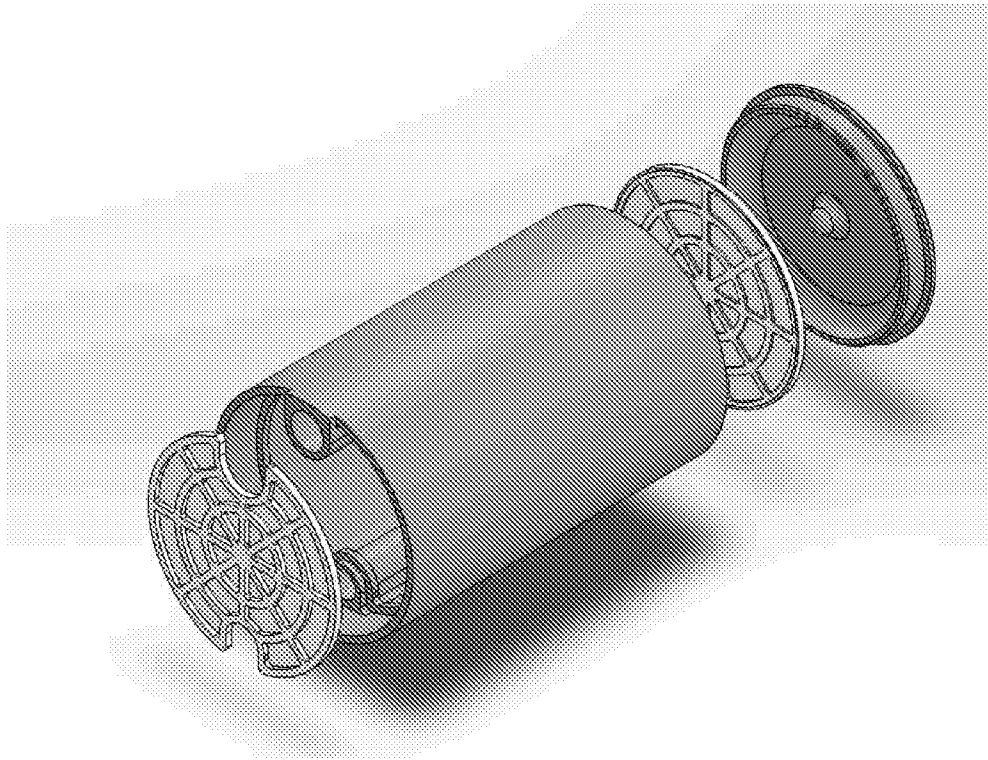

FIG. 17

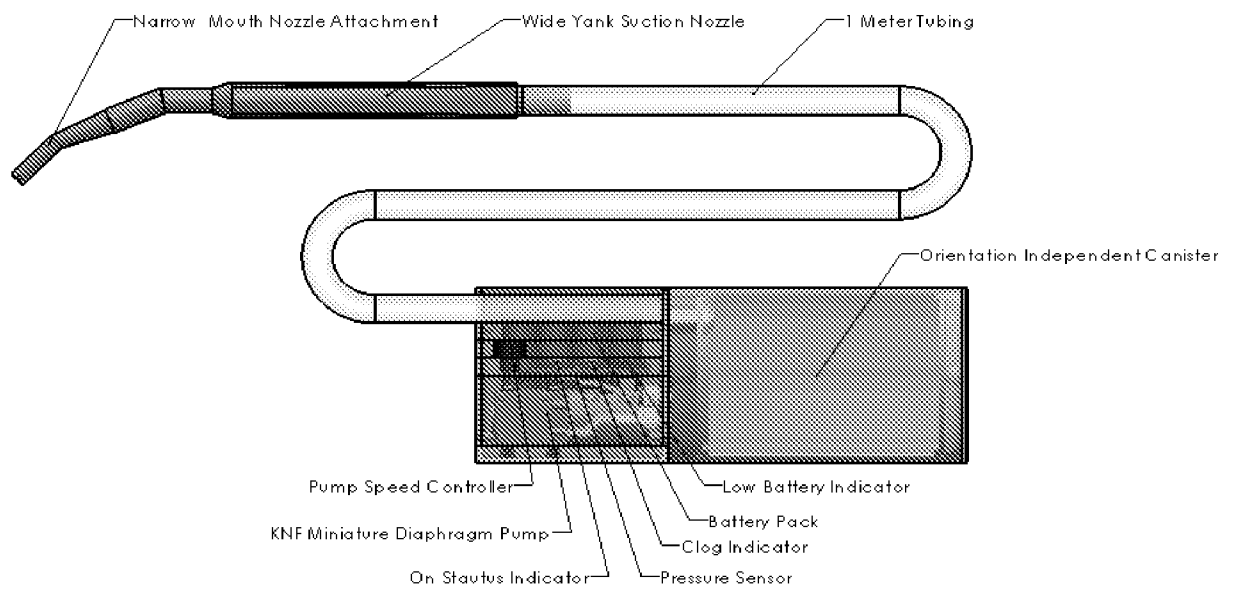

FIG. 17

## INTERNATIONAL SEARCH REPORT

International application No.

PCT/US2019/057008

## A. CLASSIFICATION OF SUBJECT MATTER

IPC(8) - A61M 16/04; A61M 1/00; A61M 11/00; A61M 15/00; A61M 16/00; A61M 16/06 (2019.01)

CPC - A61M 16/0463; A61M 1/0003; A61M 1/0031; A61M 16/00; A61M 2016/0027; A61M 16/024;  
A61M 2205/82; A61M 2210/0618 (2019.08)

According to International Patent Classification (IPC) or to both national classification and IPC

## B. FIELDS SEARCHED

Minimum documentation searched (classification system followed by classification symbols)

See Search History document

Documentation searched other than minimum documentation to the extent that such documents are included in the fields searched

See Search History document

Electronic data base consulted during the international search (name of data base and, where practicable, search terms used)

See Search History document

## C. DOCUMENTS CONSIDERED TO BE RELEVANT

Category*	Citation of document, with indication, where appropriate, of the relevant passages	Relevant to claim No.
A	US 2015/0190598 A1 (ULVAC KIKO, INC. et al) 09 July 2015 (09.07.2015) entire document	1-3, 24-26
A	US 2015/0126927 A1 (MEDINVENT, LLC) 07 May 2015 (07.05.2015) entire document	1-3, 24-26
A	US 2009/0281454 A1 (BAKER et al) 12 November 2009 (12.11.2009) entire document	1-3, 24-26
A	US 5,642,730 A (BARAN) 01 July 1997 (01.07.1997) entire document	1-3, 24-26
A	US 5,488,949 A (KREIFELS et al) 06 February 1996 (06.02.1996) entire document	1-3, 24-26

 Further documents are listed in the continuation of Box C. See patent family annex.

\* Special categories of cited documents:

"A" document defining the general state of the art which is not considered to be of particular relevance

"E" earlier application or patent but published on or after the international filing date

"L" document which may throw doubts on priority claim(s) or which is cited to establish the publication date of another citation or other special reason (as specified)

"O" document referring to an oral disclosure, use, exhibition or other means

"P" document published prior to the international filing date but later than the priority date claimed

"T" later document published after the international filing date or priority date and not in conflict with the application but cited to understand the principle or theory underlying the invention

"X" document of particular relevance; the claimed invention cannot be considered novel or cannot be considered to involve an inventive step when the document is taken alone

"Y" document of particular relevance; the claimed invention cannot be considered to involve an inventive step when the document is combined with one or more other such documents, such combination being obvious to a person skilled in the art

"&amp;" document member of the same patent family

Date of the actual completion of the international search

28 November 2019

Date of mailing of the international search report

**26 DEC 2019**

Name and mailing address of the ISA/US

Mail Stop PCT, Attn: ISA/US, Commissioner for Patents  
P.O. Box 1450, Alexandria, VA 22313-1450  
Facsimile No. 571-273-8300

Authorized officer

Blaine R. Copenheaver

PCT Helpdesk: 571-272-4300  
PCT OSP: 571-272-7774

INTERNATIONAL SEARCH REPORT

International application No.

PCT/US2019/057008

**Box No. II Observations where certain claims were found unsearchable (Continuation of item 2 of first sheet)**

This international search report has not been established in respect of certain claims under Article 17(2)(a) for the following reasons:

1.  Claims Nos.:  
because they relate to subject matter not required to be searched by this Authority, namely:
  
2.  Claims Nos.:  
because they relate to parts of the international application that do not comply with the prescribed requirements to such an extent that no meaningful international search can be carried out, specifically:
  
3.  Claims Nos.: 4-20, 23, 27-46  
because they are dependent claims and are not drafted in accordance with the second and third sentences of Rule 6.4(a).

**Box No. III Observations where unity of invention is lacking (Continuation of item 3 of first sheet)**

This International Searching Authority found multiple inventions in this international application, as follows:

1.  As all required additional search fees were timely paid by the applicant, this international search report covers all searchable claims.
2.  As all searchable claims could be searched without effort justifying additional fees, this Authority did not invite payment of additional fees.
3.  As only some of the required additional search fees were timely paid by the applicant, this international search report covers only those claims for which fees were paid, specifically claims Nos.:
  
4.  No required additional search fees were timely paid by the applicant. Consequently, this international search report is restricted to the invention first mentioned in the claims; it is covered by claims Nos.:

- Remark on Protest**
- The additional search fees were accompanied by the applicant's protest and, where applicable, the payment of a protest fee.
  - The additional search fees were accompanied by the applicant's protest but the applicable protest fee was not paid within the time limit specified in the invitation.
  - No protest accompanied the payment of additional search fees.