

C. H. Weigle,

Bench Plane.

No 102,630.

Patented May 3, 1870.

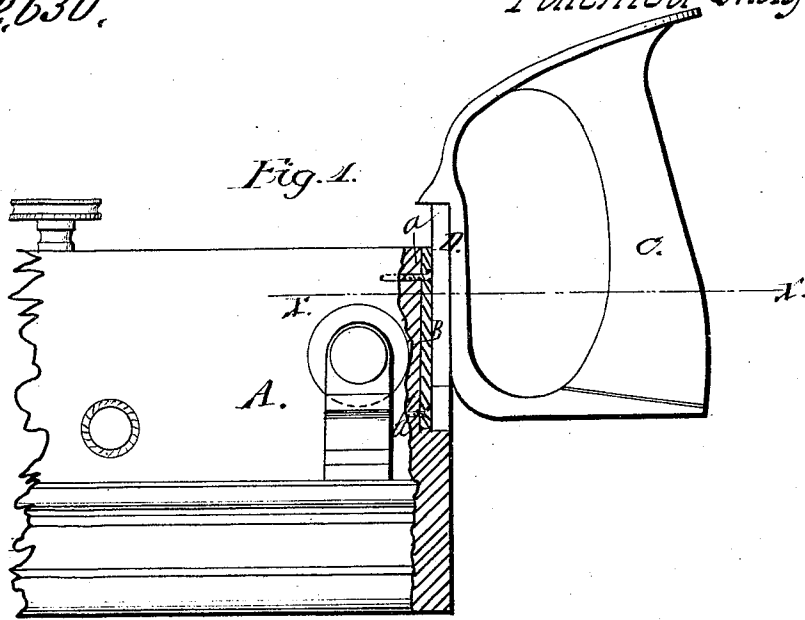
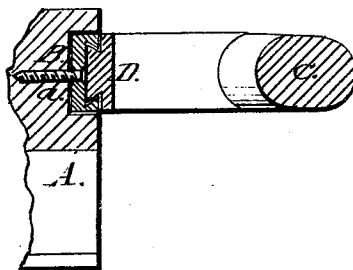

Fig. 2.



Witnesses:
H. A. Morgan
G. C. Cotton

Inventor:
C. H. Weigle
per *[Signature]*
Attorneys

United States Patent Office.

CHARLES H. WEIGLE, OF YORK, PENNSYLVANIA.

Letters Patent No. 102,630, dated May 3, 1870.

IMPROVEMENT IN ATTACHING HANDLES TO JOINERS' PLOWS.

The Schedule referred to in these Letters Patent and making part of the same.

To all whom it may concern:

Be it known that I, CHARLES H. WEIGLE, of York, in the county of York and State of Pennsylvania, have invented a new and useful Improvement in Removable Handles for Joiners' Plows and Arm-Fillisters; and I do hereby declare that the following is a full, clear, and exact description thereof, which will enable others skilled in the art to make and use the same, reference being had to the accompanying drawings forming part of this specification, in which—

Figure 1 represents a side view of my invention, partly in section.

Figure 2 is a horizontal section of the same, taken in the line *x x*, fig. 1.

Similar letters of reference indicate like parts.

This invention relates to a new and useful mode of applying handles to joiners' plows and arm-fillisters, whereby said implements may be used with a handle, and with far greater facility than hitherto, the handle being readily detached when the tool is not required for use, and is to be stowed away.

The invention consists in having a dovetail install-socket secured in the rear of the stock of the tool, and having the front edge of the handle provided with a dovetail metallic nib to fit into the socket, as hereinafter fully shown and described, whereby the desired end is attained.

A represents a portion of the stock of an ordinary joiners' plane, and

B is a metallic dovetail socket, which is let in the rear end of the stock, and secured in position by screws *a*.

C represents a wooden handle, which is constructed similarly to a saw-handle, and has a metallic rib, D, secured to its front side, said rib having a dovetail at its front part to fit into the socket B.

By this means the handle may be readily fitted to the plow, and also readily detached therefrom.

One handle will answer for a number of different tools, if they are all provided with a socket, B; and, when a plow is not in use, the handle may be detached, and the former put away without monopolizing any more room than usual.

I am aware that a patent was issued to W. S. Loughbrough, April 4, 1854, having a similar object in view, and I therefore disclaim as any part of my invention all features of construction found therein.

Having thus described my invention,

I claim as new and desire to secure by Letters Patent—

The metal dovetail socket B, secured by screws *a* in a recess in the rear end of the wooden stock A of the plane, and adapted to receive the rib D on the front edge of the handle C, all as shown and described.

CHAS. H. WEIGLE.

Witnesses:

WILLIAM DENULY,
JOHN B. WENTZ.