



INTERNATIONAL APPLICATION PUBLISHED UNDER THE PATENT COOPERATION TREATY (PCT)

<p>(51) International Patent Classification ⁷ : G11B 23/087</p>	<p>A1</p>	<p>(11) International Publication Number: WO 00/25315</p> <p>(43) International Publication Date: 4 May 2000 (04.05.00)</p>
<p>(21) International Application Number: PCT/JP99/05932</p> <p>(22) International Filing Date: 27 October 1999 (27.10.99)</p> <p>(30) Priority Data: 10/305339 27 October 1998 (27.10.98) JP</p> <p>(71) Applicant (for all designated States except US): FUJI PHOTO FILM CO., LTD. [JP/JP]; 210, Nakanuma, Minami-ashigara-shi, Kanagawa 250-0193 (JP).</p> <p>(72) Inventors; and (75) Inventors/Applicants (for US only): KITA, Akihisa [JP/JP]; Fuji Photo Film Co., Ltd., 2-12-1, Ogi-cho, Odawara-shi, Kanagawa 250-0001 (JP). YAMAGUCHI, Tatsuya [JP/JP]; Fuji Photo Film Co., Ltd., 2-12-1, Ogi-cho, Odawara-shi, Kanagawa 250-0001 (JP).</p> <p>(74) Agent: WATANABE, Mochitoshi; Hayakawa-Tonakai Building, 3rd floor, 12-5, Iwamoto-cho 2-chome, Chiyoda-ku, Tokyo 101-0032 (JP).</p>		<p>(81) Designated States: CN, KR, US, European patent (AT, BE, CH, CY, DE, DK, ES, FI, FR, GB, GR, IE, IT, LU, MC, NL, PT, SE).</p> <p>Published <i>With international search report.</i></p>
<p>(54) Title: A REEL SPRING FOR USE OF A MAGNETIC TAPE CASSETTE AND A MAGNETIC TAPE CASSETTE</p>		
<p>(57) Abstract</p>		
<p>The reel spring for use of a magnetic tape cassette comprises a fixing portion which is fixed to a boss of a cassette case by means of a boss hole, an arm portion which forces a reel in an axial direction of rotation and a bending portion provided between the fixing portion and the arm portion in an L-like shape. The ratio of a length of the fixing portion of the reel spring to a height of the boss is 4.0 or more. The length of the fixing portion is longer than that of the arm portion by 1mm to 5mm. The magnetic tape cassette employs the reel spring which is capable of enhancing production efficiency in fabricating the magnetic tape cassette while maintaining a specified force of the reel spring.</p>		

FOR THE PURPOSES OF INFORMATION ONLY

Codes used to identify States party to the PCT on the front pages of pamphlets publishing international applications under the PCT.

AL	Albania	ES	Spain	LS	Lesotho	SI	Slovenia
AM	Armenia	FI	Finland	LT	Lithuania	SK	Slovakia
AT	Austria	FR	France	LU	Luxembourg	SN	Senegal
AU	Australia	GA	Gabon	LV	Latvia	SZ	Swaziland
AZ	Azerbaijan	GB	United Kingdom	MC	Monaco	TD	Chad
BA	Bosnia and Herzegovina	GE	Georgia	MD	Republic of Moldova	TG	Togo
BB	Barbados	GH	Ghana	MG	Madagascar	TJ	Tajikistan
BE	Belgium	GN	Guinea	MK	The former Yugoslav Republic of Macedonia	TM	Turkmenistan
BF	Burkina Faso	GR	Greece			TR	Turkey
BG	Bulgaria	HU	Hungary	ML	Mali	TT	Trinidad and Tobago
BJ	Benin	IE	Ireland	MN	Mongolia	UA	Ukraine
BR	Brazil	IL	Israel	MR	Mauritania	UG	Uganda
BY	Belarus	IS	Iceland	MW	Malawi	US	United States of America
CA	Canada	IT	Italy	MX	Mexico	UZ	Uzbekistan
CF	Central African Republic	JP	Japan	NE	Niger	VN	Viet Nam
CG	Congo	KE	Kenya	NL	Netherlands	YU	Yugoslavia
CH	Switzerland	KG	Kyrgyzstan	NO	Norway	ZW	Zimbabwe
CI	Côte d'Ivoire	KP	Democratic People's Republic of Korea	NZ	New Zealand		
CM	Cameroon			PL	Poland		
CN	China	KR	Republic of Korea	PT	Portugal		
CU	Cuba	KZ	Kazakstan	RO	Romania		
CZ	Czech Republic	LC	Saint Lucia	RU	Russian Federation		
DE	Germany	LI	Liechtenstein	SD	Sudan		
DK	Denmark	LK	Sri Lanka	SE	Sweden		
EE	Estonia	LR	Liberia	SG	Singapore		

DESCRIPTION

A REEL SPRING FOR USE OF A MAGNETIC TAPE CASSETTE AND A
MAGNETIC TAPE CASSETTE

5

Technical Field

The present invention relates to a reel spring of a
magnetic tape cassette for forcing in a direction to a reel
around which a magnetic tape is wound and which is rotatably
10 provided in a cassette case. The present invention also
relates to a magnetic tape cassette using the reel spring.

Background Art

In audio set equipment, video set equipment or the like,
15 a magnetic tape cassette which allows a magnetic tape wound
around a pair of reels to run in a cassette case to perform
recording and replaying has generally been used.

In such magnetic tape cassette, a pair of reel springs
are provided in the cassette case to prevent the pair of
20 reels around which a magnetic tape is wound from displacing
in an axial direction of rotation and to allow the tape to
run smoothly whereupon the pair of reels are forced on in the
axial direction of rotation in the cassette case by the pair
of reel springs each other.

25 FIG. 3 shows a part of a digital video cassette L type
(DVC-L) as a digital video cassette for business use which
has such reel springs.

As shown in FIG. 3, the digital video cassette 30
comprises an upper half 32 of a cassette case, a pair of
30 reels 34 around which a magnetic tape is wound and which are
rotatably provided in the cassette case and a pair of reel
springs which are each a flat plate in an approximately

rectangular shape having a bending portion in a midway in a longitudinal direction to form an L-like shape, as well as other members not shown in the figure such as a lower half as a part of the cassette case, an outer lid, an upper lid and an inner lid which constitute a lid to cover an opening in the front of the cassette case, various springs and the like.

The reel spring 36, as shown in FIGS. 4A and 4B, has a fixing portion 36a which is fixed to the cassette case to form a fixing end, an arm portion 36b which forces on the aforementioned reel in the axial direction of rotation and a bending portion 36c provided between the fixing portion 36a and the arm portion 36b.

The fixing portion 36a has a boss hole 46. The boss hole 46 is provided so as to fix the reel spring 36 to a reel spring provision portion 40 which is provided in the upper half 32 of the cassette case shown in FIG. 3.

An end of the reel spring 36 is chamfered off in a triangular shape and the other end thereof in a circular shape.

A length of the arm portion 36b, namely a length from the bending portion 36c to an edge of the arm portion 36b, is needed to be long within an extent enough for keeping an urging force consistently, for reducing variation of the urging force by device of a variation of dimension of the reel spring 36 inherent to mass production of reel spring 36 which forces a reel 34 with a specified urging force, exemplified by a variation of bending angle of bending portion 36c.

Moreover, ratio of a length of the fixing portion 36a, which is defined by a length from the bending portion 36c to an edge of the fixing portion 36a, to the length of the arm

portion 36a is preferred to be larger within an extent enough for keeping the specified urging force consistently, though not necessarily being over 1.0, because of preventing the fixing portion 36a which should be in contact with a bottom surface of the upper half 32 from being deformed and partially lifted when the reel spring 36 forces on the reel 34, as shown in FIG. 5. Therefore, the length of the arm portion 36b is designed to be longer than that of the fixing portion 36a, for example 5mm longer.

10 The diameter of the boss hole 46 of the fixing portion 36a is formed larger than that of an upper half boss 42 so that, when the reel spring 36 is provided to a reel spring provision portion 40, it gets regulated in a lateral direction by reel spring provision portion guides 44 and the reel spring is easily engaged with the upper half boss 42 of the upper half 32.

When the digital video cassette 30 is assembled, such reel spring 36 is provided to the reel spring provision portion 40 of the upper half 32 by reel spring supply device not shown in the figure, is regulated in the lateral direction by reel spring provision portion guides 44 and mounted in a manner that the boss hole 46 is engaged with the upper half boss 42 on the upper half 32. Thereafter, the reel spring 36 is transported to a welding step of a cassette assembly line in which a top of the upper half boss 42 engaged with the boss hole 46 of the reel spring 36 is melted and the reel spring is welded to the upper half 32.

In this occasion, as described above, in order to prevent the fixing portion 36a of the reel spring 36 welded to the upper half 32 from being deformed and partially lifted from the bottom surface of the reel spring provision portion 40 (see FIG. 5), the length of the arm portion 36b is

designed longer than that of the fixing portion 36a so that the arm portion 36b contacts the bottom surface of the reel spring provision portion 40 in relation with a position of the gravity center and, accordingly, the fixing portion 36a comes to be in a lifted state. However, in a case in which the digital video cassette is a small-sized one for private use (DVC-S type) where a ratio of the length of the fixing portion 36a to a height of the upper half boss 42 is less than 4.0, as shown in FIG. 6, the boss hole 46 of the fixing portion 36a is not released (disengaged) from the upper half boss 42 of the upper half 32 so that problems such as complexity of welding operation or of transportation operation, decrease of assembling work efficiency and so forth do not occur.

In contrast, in another case in which the digital video cassette is a large-sized one for business use where the ratio is 4.0 or more as L type (DVC-L), the reel spring 36 should be longer longitudinally in accordance with the size of the digital video cassette and. As a result, when the length of the reel spring 36 comes to be longer, the length of the arm portion 36b, as well as that of the fixing portion 36a, becomes longer even if the ratio of the arm portion 36b to the fixing portion 36 and the bending angle of the bending portion 36c are not changed so that, even when the fixing portion 36a of the reel spring 36 is mounted on the reel spring provision portion 40 in a manner that the upper half boss 46 of the upper half 32 is engaged with the boss hole 46 of the reel spring 36, as shown in FIG. 7, the boss hole 46 of the fixing portion 36a is likely to be released from the upper half boss 42 on the upper half 32. Therefore, during the transportation to the welding step, instead of being laterally regulated with the reel spring provision portion

guides 44, the reel spring 36 bounces or slides in a disposal direction either of the right or left ridge of the reel spring provision portion guides 44, by vibration or the like to be dislocated from the appropriate position. Moreover, a
5 trouble occurs in a welding operation in that, at the time of welding, the welding operation must be performed by pressing the fixing portion 36a down to the bottom surface of the reel spring provision portion 40 so that it may not be lifted up.

To cope with these problems, it is conceivable to
10 provide a device to press down the reel spring 36 so that the reel spring 36 may not be dislocated from the reel spring provision portion 40 during the transportation. However, this causes transportation operation complicate.

Even if the device which presses down the reel spring 36
15 is provided during the transportation to allow the reel spring 36 to remain in an appropriate position, it is necessary to weld the upper half boss 42 with an ultrasonic welder or the like while keeping the reel spring 36 in a specified set condition preventing the fixing portion 36a
20 from being lifted up at the welding step. This causes to complicate welding step as well as welding operation at the welding step thereby leading to decrease of an assembly efficiency.

It is also conceivable that the height of the upper half
25 boss 42 is designed to be increased; however, if the height of the upper half boss 42 is increased, welding volume needed for fixing the reel spring 36 to the upper half boss 42 is increased whereupon welding time becomes longer, which leads to decrease of an efficiency of welding process.

30 It is also conceivable that the length of the fixing portion 36a is designed to be decreased to an extent that the boss hole 46 is not released from the upper half boss 42 on

the upper half 32; however, the length of the arm portion 36b is so long that the reel spring 36 can not obtain a specified force acting on the reel 34.

5 Its is further conceivable that the bending angle of the bending portion 36c of the reel spring 36 is brought to be shorter; however, the same problem as the above occurs.

Accordingly, it is an object of the present invention to solve the aforementioned problems and to provide a reel spring of a magnetic tape cassette having the ratio of a length of fixing portion to a height of an upper half boss being 4.0 or more and a magnetic tape cassette using the reel spring, wherein, when the reel spring is supplied to a cassette case, transported and welded during the assembly of the magnetic tape cassette, the reel spring can not be dislocated from an appropriate position in the cassette case, solves the complexity occurring at the welding step of the reel spring and can improve production efficiency over the prior art.

20 Disclosure of the Invention

The present invention provides a reel spring for use of a magnetic tape cassette having a cassette case and a pair of reels wound with a magnetic tape and rotatably provided in the cassette case, the reel spring for forcing one of the pair of reels in an axial direction of rotation, comprising:

25 a fixing portion for being fixed to the cassette case, the fixing portion having a boss hole for being engaged to a boss of the cassette case;

30 an arm portion which forces on the one of the reels in the axial direction of rotation; and

a bending portion to form an L-like shape provided between the fixing portion and the arm portion,

wherein a ratio of a length of the fixing portion to a height of the boss is equal to or more than 4.0, and

wherein the length of the fixing portion is longer than a length of the arm portion by from 1mm to 5mm.

5 It is preferable that the length of the fixing portion is longer than that of the arm portion by from 2mm to 3mm.

It is preferable that a position of gravity center of the reel spring is positioned at least in a region of the fixing portion from the bending portion as a border.

10 It is preferable that at least one of ends of the fixing portion and the arm portion is chamfered off.

It is preferable that the reel spring is employed in a pair, and each reel spring of the pair forces each of the pair of reels.

15 The present invention also provides a magnetic tape cassette, comprising:

a cassette case;

a pair of reels wound with a magnetic tape and rotatably provided in the cassette case; and

20 a pair of reel springs disposed to the cassette case for forcing each of the pair of reels in an axial direction of rotation, the cassette case having a pair of bosses for disposal of the pair of reel springs, each of the pair of reel springs comprising:

25 a fixing portion for being fixed to the cassette case, the fixing portion having a boss hole for being engaged to one of the pair of bosses of the cassette case to form an fixing end when it is fixed to the cassette case;

30 an arm portion for forcing on each of the reels in the axial direction of rotation; and

a bending portion to form an L-like shape provided between the fixing portion and the arm portion,

wherein a ratio of a length of the fixing portion to a height of the boss is equal to or more than 4.0, and

wherein the length of the fixing portion is longer than a length of the arm portion by from 1mm to 5mm.

5

Brief Description of Drawings

FIG. 1A is a side-elevational view of a reel spring of a digital video cassette as an embodiment of a reel spring of a magnetic tape cassette of the present invention and FIG. 1B is a plan view of the reel spring shown in FIG. 1A;

10

FIG. 2 is a cross-sectional schematic view showing a condition of the reel spring in which the reel spring for the digital video cassette shown in FIG. 1A is provided in a cassette case;

15

FIG. 3 is an disassembled perspective view showing primary portions of an example of a conventional magnetic tape cassette;

20

FIG. 4A is a cross-sectional view showing an example of a reel spring to be employed in a conventional magnetic tape cassette and FIG. 4B is a plan view of the reel spring shown in FIG. 4A;

25

FIG. 5 is a cross-sectional schematic view showing a deformation condition of the reel spring when the reel spring shown in FIG. 4A forces on a reel;

FIG. 6 is a cross-sectional schematic view showing a condition of a reel spring in which a reel spring of DVC-S type is provided in a cassette case; and

30

FIG. 7 is a cross-sectional schematic view showing a condition of a reel spring in which the reel spring of DVC-L type shown in FIG. 4A is provided in a cassette case.

Best Mode for Carrying out the Invention

A reel spring of a magnetic tape cassette and a magnetic tape cassette using the same according to the present invention will now be described in detail with reference to a preferred embodiment of a reel spring of a digital video cassette shown in the accompanying drawings.

The magnetic tape cassette of the present invention to which the reel spring of the magnetic tape cassette according to the present invention is applied has same construction as a conventional magnetic tape cassette has except for the reel spring. Therefore, in the explanation below with reference to a magnetic tape cassette to which the reel spring according to the present invention shown in FIGS. 1A and 1B is applied, the digital video cassette 30 as an embodiment of the conventional magnetic tape cassette shown in FIG. 3 is referred to and the same reference numerals except for the reel spring 36 are used.

FIGS. 1A and 1B show a reel spring of a digital video cassette as an embodiment of a reel spring of a magnetic tape cassette of the present invention.

The reel spring 10 shown in FIGS. 1A and 1B comprises a fixing portion 10a which forms a fixing end when it is fixed to a cassette case having an upper half boss 42, an arm portion 10b which forces on the aforementioned reel in an axial direction of rotation and a bending portion 10c provided between the fixing portion 10a and the arm portion 10b to form an L-shape. The fixing portion 10a has a ratio of its own length to the upper half boss 42 of 4.0 or more.

The fixing portion 10a and the arm portion 10b are separated by the bending portion 10c as a border.

As shown in FIGS. 1A and 1B, the fixing portion 10a has a boss hole 12 for fixing the reel spring 10 to a reel spring provision portion 40. One end of the reel spring is

chamfered off in a triangular form and the other end in a circular form.

In the reel spring 10, the bending portion 10c is designed in a manner that the length of the fixing portion 10a is longer than the that of the arm portion by 1mm to 5mm; this is characteristic of the present invention.

Characteristics of a material to be employed to the reel spring 10 are not limited in any way, but SUS 304 is preferably used. The bending angle of the bending portion 10c and the plate thickness of the reel spring 10 are not limited in any way, but it is preferable to set them as degrees of freedom of design so as to be able to keep the urging force to be obtained within a range of a specified amount even if the position of the bending portion 10c is designed to be modified to change the length of the arm portion 10b.

The reason why the length of the fixing portion 10a is longer than that of the arm portion 10b by 1mm to 5mm can be explained as follows:

The reel spring 10 is supplied one by one to an appropriate position and mounted thereon in a reel spring provision portion 40 on an upper half 32 with a reel spring provision device. The appropriate position is referred to as a position which is regulated by reel spring provision portion guides 44 which comprise a pair of ridges provided in accordance with the plate width of the reel spring 36 and to which the reel spring is secured by engaging an upper half boss 42 provided in the reel spring provision portion 40 to the boss hole 12.

According to the present invention, since the length of the fixing portion 10a is longer than that of the arm portion 10b and a position of a gravity center of the reel spring 10

is located in the region of the fixing portion 10a, when the reel spring is provided in an appropriate position, as shown in FIG. 2, the whole area of the fixing portion 10a closely contacts the bottom surface of the reel spring provision
5 portion 40 and moreover the reel spring 10 is firmly fixed to the upper half boss 42 without being released therefrom.

On the other hand, in the conventional reel spring 36, since the length of the arm portion 36b is longer than that of the fixing portion 36a, the position of the gravity center
10 is located in the region of the arm portion 36b so that, as shown in FIG. 7, the fixing portion 36a is lifted up from the bottom surface of the reel spring provision portion 40 and moreover is released from the upper half boss 42.

In such case, the reel spring 36 is easily dislocated
15 from the appropriate position by vibration or the like during the transportation to the welding step of the reel spring as described above so that it is necessary to place the reel spring back to the appropriate position again. Moreover, in the welding step, the reel spring with its lifted fixing
20 portion 36a is necessary to be held during the welding step in a manner that the whole area of the fixing portion 36a keeps contact with the bottom surface of the reel spring provision portion 40; this leads to decrease of an efficiency of the welding step.

25 However, according to the present invention, since the fixing portion 10a is stably placed in a manner that it contacts the bottom surface of the reel spring provision portion 40, as shown in FIG. 2, the upper half boss 42 can not be released from the boss hole 12, as shown in FIG. 6.
30 This will ensure that the reel spring 10 is not dislocated from the appropriate position in the cassette case during the transportation to the welding step and has the fixing portion

10a also stably positioned on the bottom surface of the reel spring provision portion 40 during the welding step so that it is not necessary to do extra work to hold the fixing portion 10a to keep contact with the bottom surface of the reel spring provision 40 as has been done with the conventional reel spring 36 whereupon work efficiency of the welding step is improved over that of the conventional welding step.

With reference to the reel spring 10 according to the present invention, the length of the fixing portion 10a is longer than that of the arm portion 10b; the difference therebetween is from 1mm to 5mm.

If the above difference is designed to be less than 1mm, then, as shown in FIG. 1B, since the reel spring 10 is chamfered off in a triangular and circular forms and is provided with the boss hole 12, the portion of gravity center of the reel spring 10 is not necessarily positioned in the region of the fixing portion 10a but rather in the vicinity of the bending portion 10c so that the fixing portion 10a may come out of balance due to small vibration or unevenness of the bottom surface of the reel spring provision portion 40 to be lifted up from the bottom surface of the reel spring provision portion 40. For this reason, the position of the gravity center of the reel spring 10 is to be positioned at least in the region of the fixing portion 10a from the bending portion 10c as a border.

The difference between the length of the fixing portion 10a and the length of the arm portion 10b is defined as being 5mm or less because, if the difference is over 5mm, the arm portion gets short in comparison with those of other modified reel springs within a range of a specified urging force and the urging force gets more variable by means of an individual

variation of mass produced reel springs, for example, the variation of the bending angle of the bending portion, whereby a specified urging force can not be obtained.

Moreover, if the difference is over 5mm, as described above,

5 when the reel is provided with the urging force, a part of the fixing portion 10a is bent to be lifted as shown in FIG. 5 so that it will be difficult to generate a specified urging force. Furthermore, spring rate of the reel spring 10 is formulated by the length of the arm portion 10b to the minus
10 third power so that, if the difference between the length of the fixing portion 10a and the length of the arm portion 10b is longer than 5mm, the length of the arm portion becomes shorter whereby the spring rate increases sharply and it becomes difficult to maintain the spring modulus within a
15 specified amount so as to exert a specified urging force even if the plate thickness or a bending angle of the bending portion 10c of the reel spring 10 is designed to be changed. In addition, variation of the spring rate generated based on variation of the position of the bending portion 10c becomes
20 larger as the length of the arm portion 10b becomes shorter whereby it becomes difficult to maintain the specified urging force within an allowable range.

As described above, the present invention is characterized in that the length of the fixing portion 10a is
25 longer than the length of the arm portion 10b by from 1mm to 5mm; however, in order to exert the effect of the present invention more conspicuously, it is preferable that the length of the fixing portion 10a is longer than the length of the arm portion 10b by from 2mm to 3mm.

30 With reference to such reel spring according to the present invention, an example of specified dimensions will be described below.

The magnetic tape cassette is of digital video cassette L type (DVC-L). A reel spring 10 for use in this digital video cassette has a plate thickness of 0.2mm, the length of the arm portion 10b of 19mm and the length of the fixing portion 10a of 21mm which is longer than the length of the arm portion 10b by 2mm. Accordingly, the fixing portion 10a contacts the bottom surface of the reel spring provision portion 40 to be engaged to the upper half boss 42. The bending angle of the bending portion 10c is 16 degrees and the ratio of the length of the fixing portion 10a to the height of the upper half boss 42 is 9.5.

On the other hand, the conventional reel spring 36 has a plate thickness of 0.25mm, the length of the arm portion 36b of 22.5mm and the length of the fixing portion 36a of 17.5mm which is shorter than the arm portion 36b by 5mm. The bending angle at the bending portion 10c is 11 degrees. In this case, the fixing portion 36a is lifted up from the bottom surface of the reel spring provision portion 40 and the height of the boss hole 46 from the bottom surface exceeds the height of the upper half boss 42 of 2mm whereby the boss hole 46 can not be caught by the upper half boss 42.

The length of the arm portion 10b of the reel spring 10 according to the present invention is shorter than that of the arm portion 36b of the conventional reel spring 36 by 3.5mm so that, in order to generate the specified urging force, the plate thickness is decreased from 0.25mm to 0.2mm and also the bending angle is finely adjusted to change from 11 degrees to 16 degrees. In this case, the material for use in the reel spring is SUS 304.

The reel spring of the magnetic tape cassette and the magnetic tape cassette according to the present invention have been described above in detail. Of course, the present

invention is not limited to the above described embodiments, and it is possible to effect a variety of improvements or modifications without departing from the scope and the spirit of the present invention.

5

Industrial Applicability

The reel spring of the magnetic tape cassette according to the present invention changes the position of the bending portion of the conventional reel spring to increase the length of the fixing portion allowing it to be longer than that of the arm portion by from 1mm to 5mm whereupon, when it is provided in an appropriate position, the fixing portion is stably placed keeping in contact with the bottom surface of the cassette case; hence, it is not necessary to take the trouble to keep the fixing portion in contact with the bottom surface of the cassette case as has been conventionally done, welding operation at the time of welding the reel spring is performed in a smooth manner and, moreover, since not only the fixing portion contacts the bottom surface of the cassette case, but also the reel spring is engaged to the boss of the cassette by allowing the boss of the cassette to get through the boss hole of the reel spring, the reel spring is not dislocated from the appropriate position by the vibration or the like while the cassette case is transported to the welding step so that the welding operation can be started right after the cassette case is transported to the welding step. This will increase the efficiency of the welding operation and, as a result, lead to enhancement of the production efficiency of the magnetic tape cassette.

CLAIMS

1. A reel spring for use of a magnetic tape cassette having a cassette case and a pair of reels wound with a magnetic tape and rotatably provided in said cassette case, said reel spring for forcing one of said pair of reels in an axial direction of rotation, comprising:

a fixing portion for being fixed to said cassette case, said fixing portion having a boss hole for being engaged to a boss of the cassette case;

an arm portion which forces on said one of said reels in the axial direction of rotation; and

a bending portion to form an L-like shape provided between said fixing portion and said arm portion,

wherein a ratio of a length of said fixing portion to a height of the boss is equal to or more than 4.0, and

wherein said length of said fixing portion is longer than a length of said arm portion by from 1mm to 5mm.

2. The reel spring for use of the magnetic tape cassette according to claim 1, wherein the length of said fixing portion is longer than that of said arm portion by from 2mm to 3mm.

3. The reel spring for use of the magnetic tape cassette according to claim 1 or 2, wherein a position of gravity center of said reel spring is positioned at least in a region of said fixing portion from said bending portion as a border.

4. The reel spring for use of the magnetic tape cassette according to any one of claims 1 to 3, wherein at least one of ends of said fixing portion and said arm portion is chamfered off.

5

5. The reel spring for use of the magnetic tape cassette according to any one of claims 1 to 4, wherein said reel spring is employed in a pair, and each reel spring of the pair forces each of said pair of reels.

10

6. A magnetic tape cassette, comprising:

a cassette case;

a pair of reels wound with a magnetic tape and rotatably provided in said cassette case; and

15

a pair of reel springs disposed to the cassette case for forcing each of the pair of reels in an axial direction of rotation, said cassette case having a pair of bosses for disposal of the pair of reel springs, each of said pair of reel springs comprising:

20

a fixing portion for being fixed to said cassette case, said fixing portion having a boss hole for being engaged to one of the pair of bosses of the cassette case to form an fixing end when it is fixed to said cassette case;

25

an arm portion for forcing on each of said reels in the axial direction of rotation; and

a bending portion to form an L-like shape provided between said fixing portion and said arm portion,

wherein a ratio of a length of said fixing portion to a height of the boss is equal to or more than 4.0, and

30

wherein said length of said fixing portion is longer than a length of said arm portion by from 1mm to 5mm.

FIG. 1A

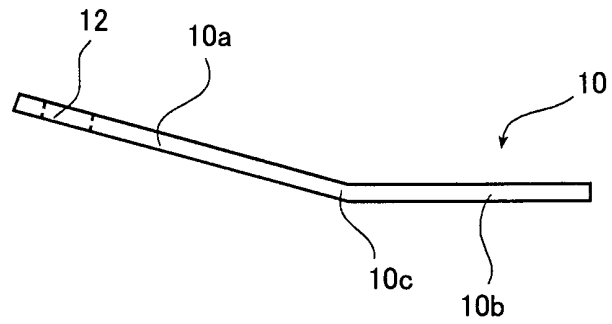

FIG. 1B

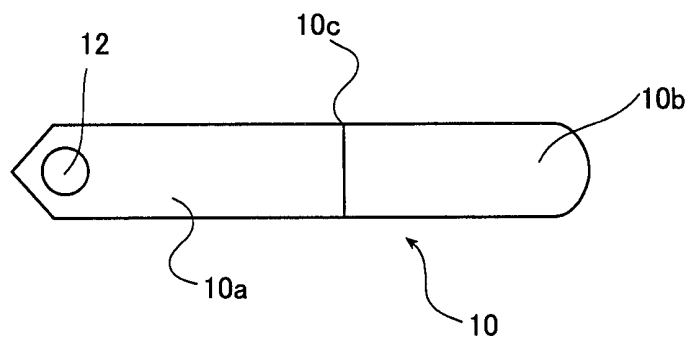
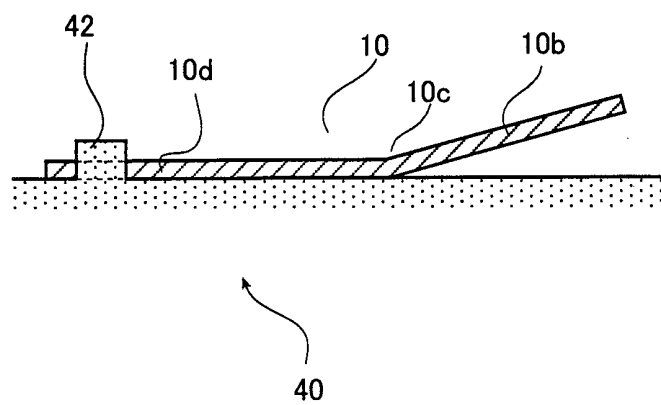

FIG. 2



2/4

FIG. 3

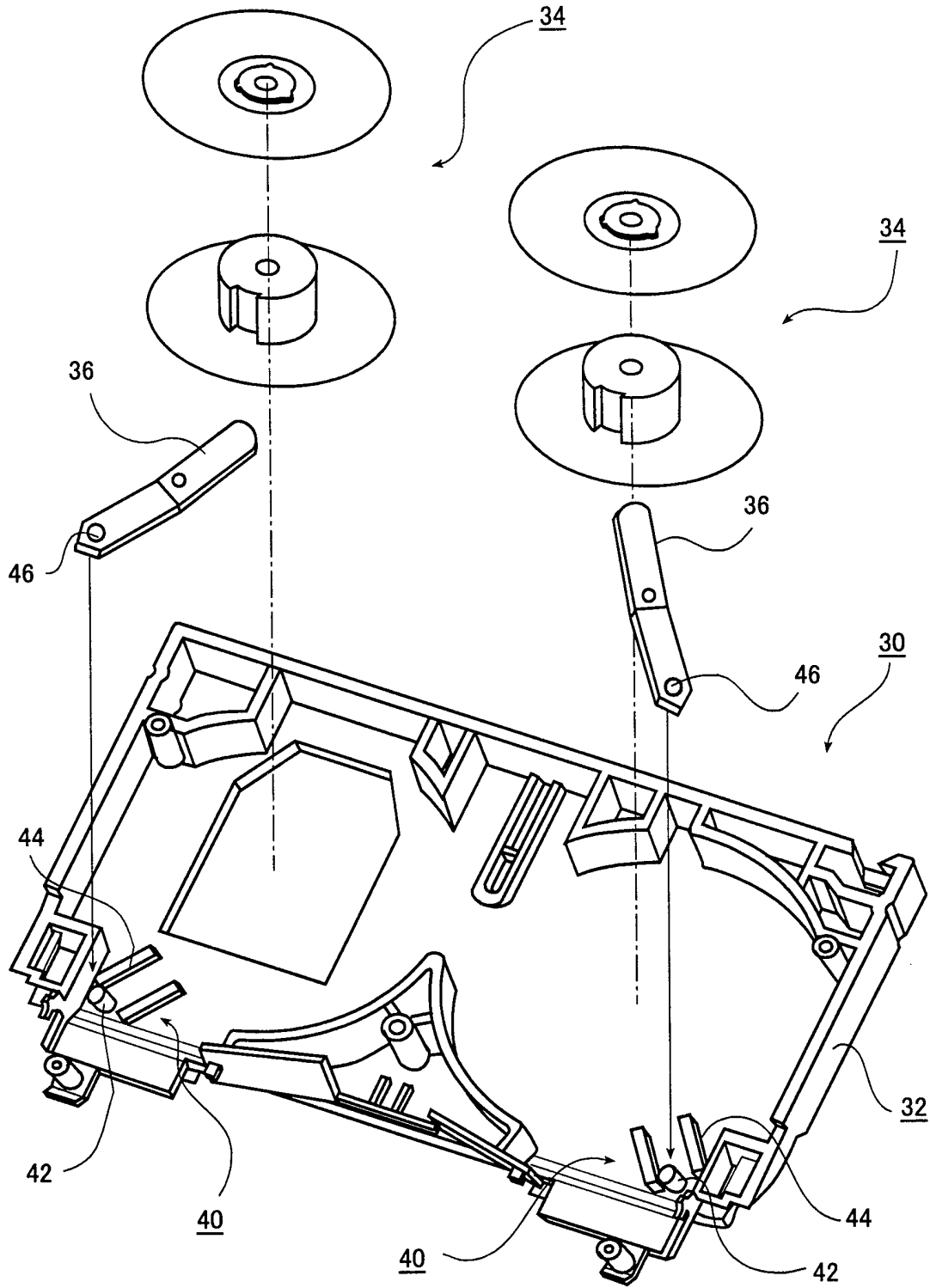

FIG. 4A

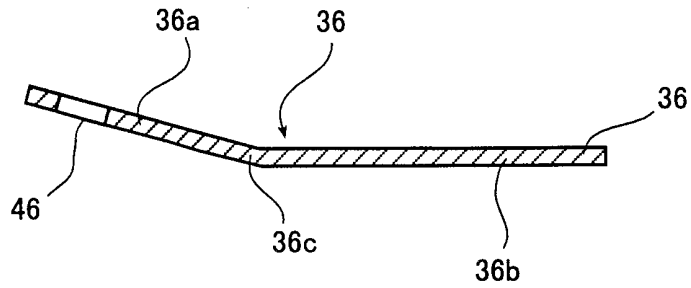

FIG. 4B

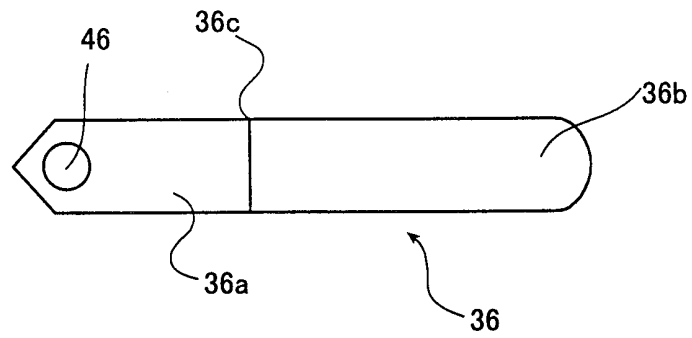

FIG. 5

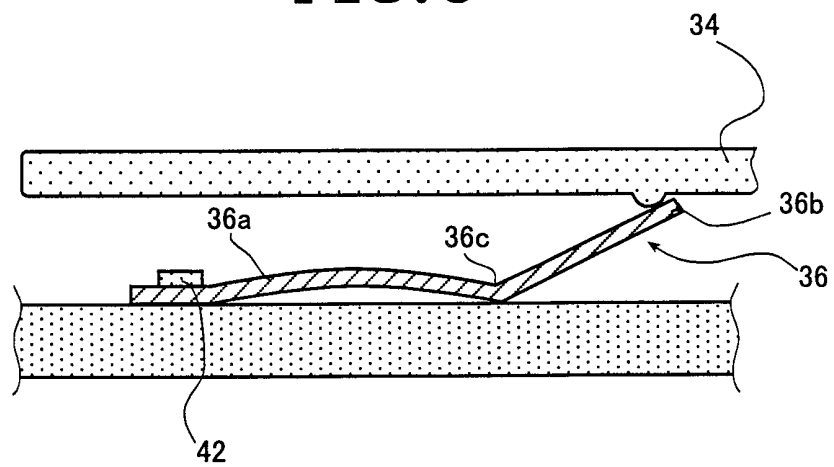

FIG. 6

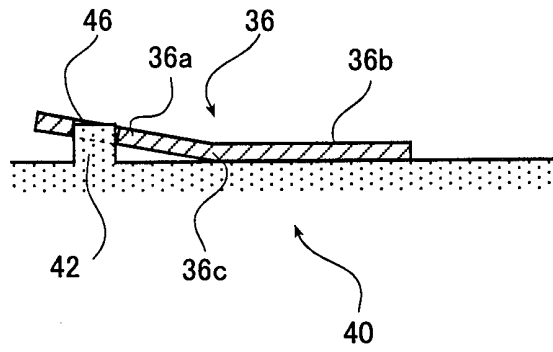
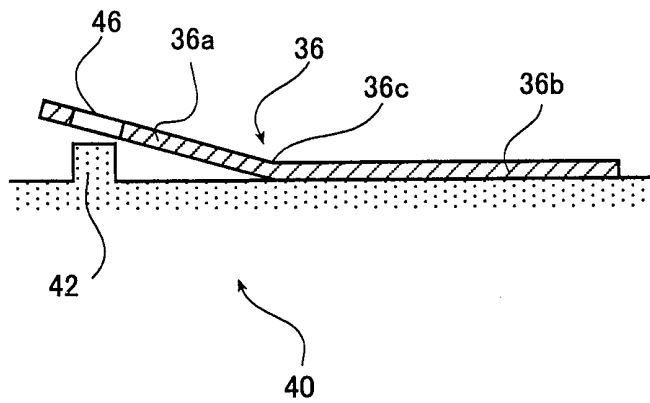

FIG. 7



INTERNATIONAL SEARCH REPORT

International Application No

PCT/JP 99/05932

A. CLASSIFICATION OF SUBJECT MATTER

IPC 7 G11B23/087

According to International Patent Classification (IPC) or to both national classification and IPC

B. FIELDS SEARCHED

Minimum documentation searched (classification system followed by classification symbols)

IPC 7 G11B

Documentation searched other than minimum documentation to the extent that such documents are included in the fields searched

Electronic data base consulted during the international search (name of data base and, where practical, search terms used)

C. DOCUMENTS CONSIDERED TO BE RELEVANT

Category °	Citation of document, with indication, where appropriate, of the relevant passages	Relevant to claim No.
A	PATENT ABSTRACTS OF JAPAN vol. 1996, no. 03, 29 March 1996 (1996-03-29) -& JP 07 296550 A (SONY CORP), 10 November 1995 (1995-11-10) abstract; figures ----	1,4-6
P,A	PATENT ABSTRACTS OF JAPAN vol. 1999, no. 11, 30 September 1999 (1999-09-30) & JP 11 149746 A (FUJI PHOTO FILM CO LTD), 2 June 1999 (1999-06-02) abstract; figure ----	1,4-6
A	GB 2 283 961 A (ACME CASSETTE MANUFACTURING LI) 24 May 1995 (1995-05-24) abstract; claims 1,2; figures page 3, line 3 - line 9 ----- -/--	1,4-6

Further documents are listed in the continuation of box C.

Patent family members are listed in annex.

° Special categories of cited documents :

- "A" document defining the general state of the art which is not considered to be of particular relevance
- "E" earlier document but published on or after the international filing date
- "L" document which may throw doubts on priority claim(s) or which is cited to establish the publication date of another citation or other special reason (as specified)
- "O" document referring to an oral disclosure, use, exhibition or other means
- "P" document published prior to the international filing date but later than the priority date claimed

- "T" later document published after the international filing date or priority date and not in conflict with the application but cited to understand the principle or theory underlying the invention
- "X" document of particular relevance; the claimed invention cannot be considered novel or cannot be considered to involve an inventive step when the document is taken alone
- "Y" document of particular relevance; the claimed invention cannot be considered to involve an inventive step when the document is combined with one or more other such documents, such combination being obvious to a person skilled in the art.
- "&" document member of the same patent family

Date of the actual completion of the international search

14 January 2000

Date of mailing of the international search report

26/01/2000

Name and mailing address of the ISA
European Patent Office, P.B. 5818 Patentlaan 2
NL - 2280 HV Rijswijk
Tel. (+31-70) 340-2040, Tx. 31 651 epo nl,
Fax: (+31-70) 340-3016

Authorized officer

Declat, M

INTERNATIONAL SEARCH REPORT

International Application No

PCT/JP 99/05932

C.(Continuation) DOCUMENTS CONSIDERED TO BE RELEVANT

Category	Citation of document, with indication, where appropriate, of the relevant passages	Relevant to claim No.
A	EP 0 225 734 A (SONY CORP) 16 June 1987 (1987-06-16) abstract; claims 1-7; figures ---	1,4-6
A	US 5 181 153 A (NISHIMURA AKIHIRO) 19 January 1993 (1993-01-19) abstract; claim 1; figures ---	1,4-6
A	WO 95 15560 A (JASON INC) 8 June 1995 (1995-06-08) abstract; claims 1-7; figures ---	1,4-6
A	GB 2 269 360 A (ACME CASSETTE MANUFACTURING LI) 9 February 1994 (1994-02-09) abstract; claim 1; figures -----	1,4-6

INTERNATIONAL SEARCH REPORT

information on patent family members

International Application No

PCT/JP 99/05932

Patent document cited in search report	A	Publication date	Patent family member(s)	Publication date
JP 07296550	A	10-11-1995	NONE	
JP 11149746	A	02-06-1999	NONE	
GB 2283961	A	24-05-1995	CN 1113339 A	13-12-1995
EP 0225734	A	16-06-1987	AU 595255 B AU 6469086 A CA 1282763 A US 4802044 A	29-03-1990 28-05-1987 09-04-1991 31-01-1989
US 5181153	A	19-01-1993	JP 2626129 B JP 3242887 A KR 9500956 B	02-07-1997 29-10-1991 06-02-1995
WO 9515560	A	08-06-1995	NONE	
GB 2269360	A	09-02-1994	NONE	