



US00D676988S

(12) **United States Design Patent**
Maxik et al.

(10) **Patent No.:** **US D676,988 S**

(45) **Date of Patent:** **** Feb. 26, 2013**

(54) **LUMINAIRE**

(75) Inventors: **Fredric S. Maxik**, Indialantic, FL (US);
David Henderson, Indialantic, FL (US);
Mark Penley Boomgaarden, Indian
Harbour Beach, FL (US); **Addy S.**
Widjaja, Palm Bay, FL (US); **Emilio**
Flores, Indian Harbor, FL (US); **Shane**
Sullivan, Indialantic, FL (US); **Wei Sun**,
Davie, FL (US)

(73) Assignee: **Lighting Science Group Corporation**,
Satellite Beach, FL (US)

(**) Term: **14 Years**

(21) Appl. No.: **29/425,139**

(22) Filed: **Jun. 20, 2012**

Related U.S. Application Data

(62) Division of application No. 29/416,010, filed on Mar.
16, 2012, which is a division of application No.
29/360,985, filed on May 4, 2010, now Pat. No. Des.
659,266.

(51) **LOC (9) Cl.** **26-04**

(52) **U.S. Cl.** **D26/2**

(58) **Field of Classification Search** D26/1-4;
313/313, 315, 316, 317, 318, 493; 315/52,
315/53, 56, 57, 58

See application file for complete search history.

(56) **References Cited**

U.S. PATENT DOCUMENTS

4,375,607 A 3/1983 Morton et al.

(Continued)

FOREIGN PATENT DOCUMENTS

WO 2006118457 11/2006
WO 2008113837 A2 9/2008

OTHER PUBLICATIONS

<http://img.diytrade.com/cdimg/395588/7678937/> . . . <http://images.google.com/imgres?imgurl=http://img.diytrade.com/cdimg/395588/7678937/> . . .

(Continued)

Primary Examiner — Marcus Jackson
(74) *Attorney, Agent, or Firm* — Cantor Colburn LLP

(57) **CLAIM**
We claim, the ornamental design for a luminaire, as shown
and described.

DESCRIPTION

FIG. 1 is a first perspective view of an embodiment of the
invention;
FIG. 2 is a first side plan view the embodiment of FIG. 1,
the luminaire being symmetric about a center axis;
FIG. 3 is a top plan view of the embodiment of FIG. 1;
FIG. 4 is a bottom plan view of the embodiment of FIG. 1;
and,
FIG. 5 is a second perspective view of the embodiment of
FIG. 1.

The degree of transparency or opaqueness of the lens of the
luminaire forms no part of the claimed design. The lens of the
claimed luminaire may have facets, lenslets or other treat-
ments.

The dotted lines shown in FIGS. 2, 3 and 5 indicate that the
outer diameter and shape of the lens may have any size diam-
eter or curvature.

The dash-dot lines shown in FIGS. 2-5 are environmental and
not part of the claimed design.

The dash-dot-dot lines shown between the heat sink portion
and base portion in FIGS. 1, 2, 4 and 5 indicates that the heat
sink portion may be of any length.

The phantom lines shown in FIGS. 1, 2, 4 and 5 are environ-
mental and not part of the claimed design.

The color and shading of the luminaire forms no part of the
claimed design, the luminaire according to the claimed design
may be any color or combination of colors.

The surface treatment of the luminaire forms no part of the
claimed design, the luminaire of the claimed design may have
any surface treatment.

References to “side”, “top”, and “bottom” in the figure
descriptions are not meant to require certain in-use orienta-
tion; a luminaire according to the claimed design may be used
in any orientation.

1 Claim, 5 Drawing Sheets

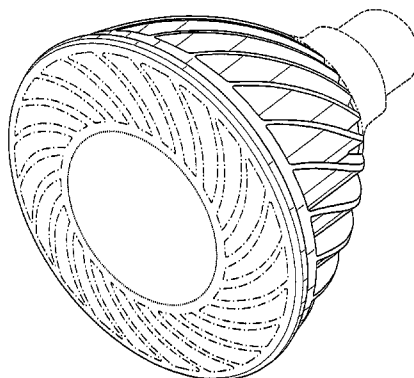

U.S. PATENT DOCUMENTS					
4,392,076 A	7/1983	Ishler et al.	D608,478 S	1/2010	Maxik et al.
D271,424 S	11/1983	Young et al.	D610,271 S	2/2010	Bi
D307,805 S	5/1990	Noe	D610,722 S	2/2010	Bi
D321,260 S	10/1991	Bowman	D612,956 S	3/2010	Moon
5,458,505 A	10/1995	Prager	D613,433 S	4/2010	Moon
D391,006 S	2/1998	Yang	7,717,590 B1	5/2010	Li
5,791,769 A	8/1998	Yang	D617,915 S	6/2010	Wada et al.
D470,610 S	2/2003	Bobel	D618,369 S	6/2010	Lee et al.
6,515,433 B1	2/2003	Ge et al.	D620,153 S	7/2010	Wang et al.
D480,486 S	10/2003	Kakuno et al.	D621,973 S	8/2010	Grajcar
6,655,823 B2	12/2003	Chang	D621,974 S	8/2010	Grajcar
6,786,625 B2	9/2004	Wesson	D623,777 S	9/2010	Moon et al.
D497,439 S	10/2004	Shaw et al.	D623,778 S	9/2010	Moon et al.
6,848,812 B1	2/2005	Hsieh	D623,779 S	9/2010	Wang et al.
D508,575 S	8/2005	Buschmann et al.	D624,214 S	9/2010	Thomas et al.
D516,229 S	2/2006	Tang	D624,215 S	9/2010	Moon et al.
D527,119 S	8/2006	Maxik et al.	D624,669 S	9/2010	Tsai
D528,227 S	9/2006	Chou et al.	D625,437 S	10/2010	Zhang et al.
D528,673 S	9/2006	Maxik et al.	D626,260 S	10/2010	Wei
D531,741 S	11/2006	Takahashi	D626,667 S	11/2010	Jonsson et al.
D534,665 S	1/2007	Egawa et al.	D627,087 S	11/2010	Jonsson et al.
D538,950 S	3/2007	Maxik	D628,322 S	11/2010	Sakai et al.
D538,951 S	3/2007	Maxik et al.	D628,720 S	12/2010	Wang
D538,952 S	3/2007	Maxik et al.	D629,129 S	12/2010	Lin et al.
D541,957 S	5/2007	Wang	D629,930 S	12/2010	Cotter et al.
D542,943 S	5/2007	Wang	D630,347 S	1/2011	Pei et al.
D545,457 S	6/2007	Chen	D634,031 S	3/2011	de Visser et al.
7,226,189 B2	6/2007	Lee et al.	D634,037 S	3/2011	Jeong et al.
D546,980 S	7/2007	Lo	D635,105 S	3/2011	Maxik et al.
D549,854 S	8/2007	Takahashi	D636,902 S	4/2011	Pei et al.
D560,286 S	1/2008	Maxik et al.	D636,904 S	4/2011	Leahy et al.
D563,572 S	3/2008	Lukacs	D640,820 S	6/2011	Hopper
D566,300 S	4/2008	Lo	D646,409 S	* 10/2011	MacDonald et al. D26/2
7,367,688 B1	5/2008	Bucher et al.	D648,041 S	11/2011	Mahler et al.
D570,504 S	6/2008	Maxik et al.	D650,495 S	12/2011	Foo
D570,505 S	6/2008	Maxik et al.	D652,564 S	1/2012	Maxik
D572,358 S	7/2008	Nattrass et al.	D654,192 S	2/2012	Maxik et al.
D572,385 S	7/2008	Mazzochette et al.	D656,631 S	3/2012	Leahy et al.
7,434,964 B1	10/2008	Zheng et al.	D658,791 S	5/2012	Maxik et al.
D581,554 S	11/2008	To et al.	D659,266 S	5/2012	Maxik et al.
D581,583 S	11/2008	Peng	D662,627 S	6/2012	Pan
7,448,772 B2	11/2008	Hampton	D663,051 S	7/2012	Xu et al.
D584,428 S	1/2009	Li et al.	D663,057 S	7/2012	Pan
D584,837 S	1/2009	Mazzochette et al.	D663,446 S	7/2012	Maxik et al.
D586,497 S	2/2009	Wu et al.	D665,107 S	8/2012	Tu
7,513,653 B1	4/2009	Liu et al.	2006/0215408 A1	9/2006	Lee
D592,766 S	5/2009	Zhu et al.	2007/0285926 A1	12/2007	Maxik
D593,222 S	5/2009	To et al.	2008/0253125 A1	10/2008	Kang et al.
D594,143 S	6/2009	Montagnat et al.	2009/0141500 A1	6/2009	Peng
D594,995 S	6/2009	Komar	2009/0296402 A1	12/2009	Chang et al.
D595,893 S	7/2009	Maxik et al.	2010/0027270 A1	2/2010	Huang et al.
D597,225 S	7/2009	Yoo	2010/0091487 A1	4/2010	Shin
D597,704 S	8/2009	Peng			
D599,041 S	8/2009	Yoo			
D600,850 S	9/2009	Maxik et al.			
D601,275 S	9/2009	Ho et al.			
D601,276 S	9/2009	Grajcar			
D601,277 S	9/2009	Grajcar			
D601,278 S	9/2009	Takahashi			
D601,279 S	9/2009	Ou et al.			
D607,586 S	1/2010	Ko			

OTHER PUBLICATIONS

SP-E27 LB60 Nicha / Cree LED Lamp, posted Dec. 18, 2008, http://www.diytrade.com/china/4/products/4950147/SP-E27_LB60_Nicha_Cree_LED_Lamp.html, accessed Jun. 30, 2009.
 F.S. Maxik, "GU10 Lamp" Office Action mailed Mar. 16, 2011; U.S. Appl. No. 29/340,670 filed Jul. 23, 2009.

* cited by examiner

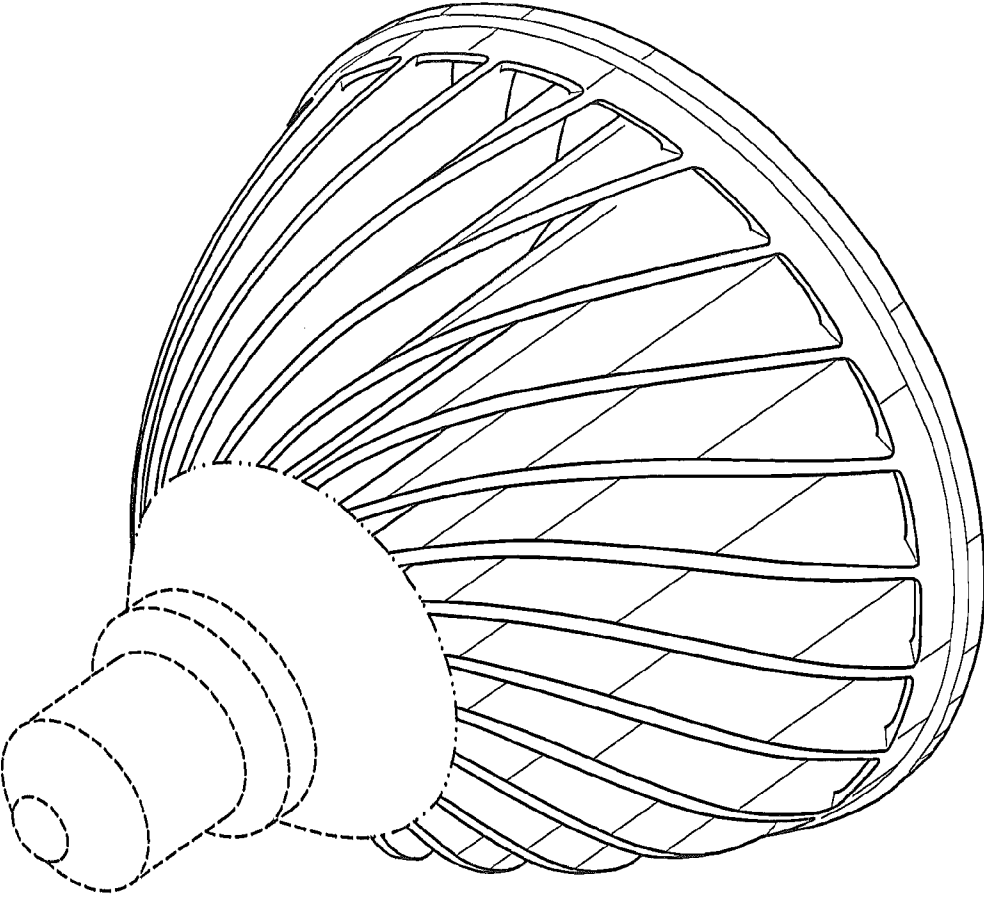

FIG. 1

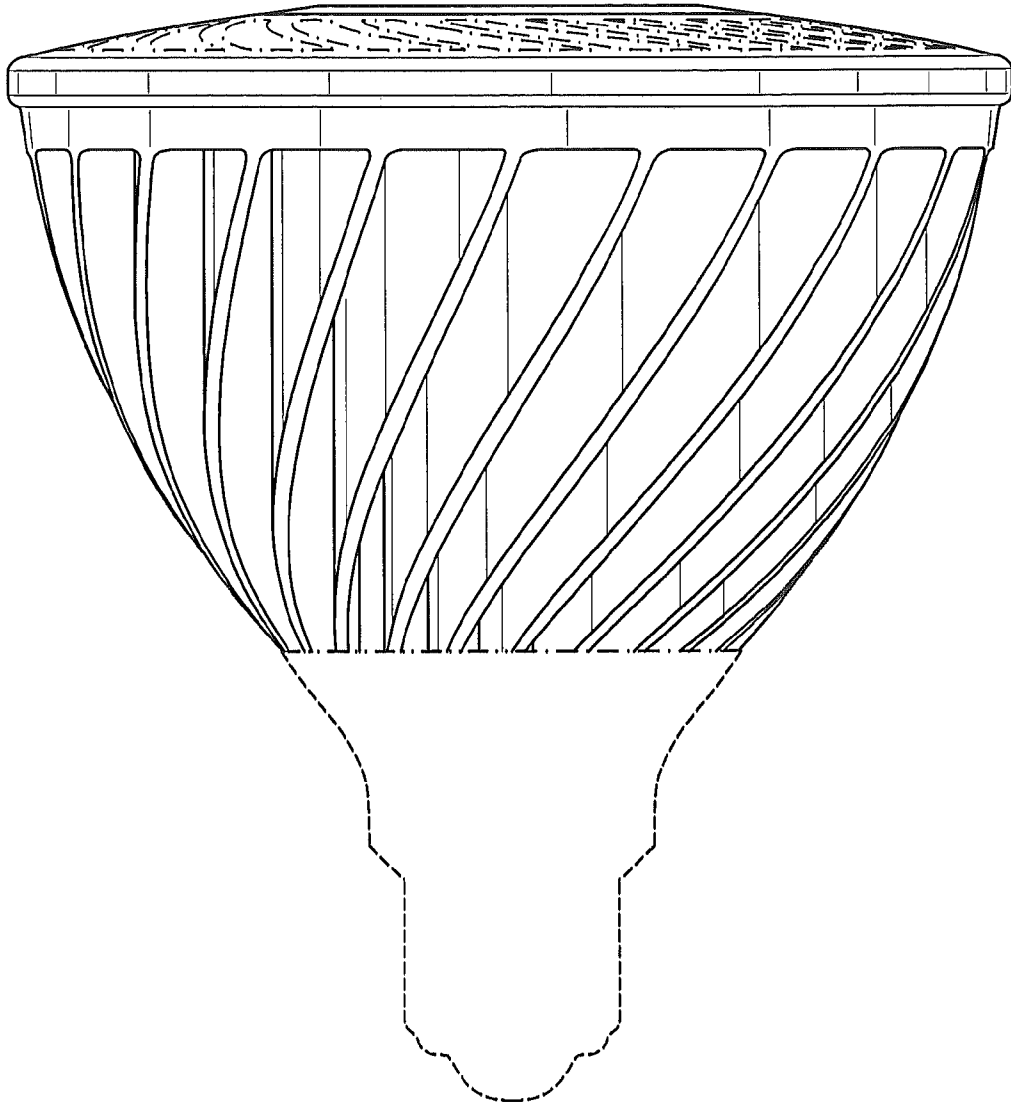

FIG 2

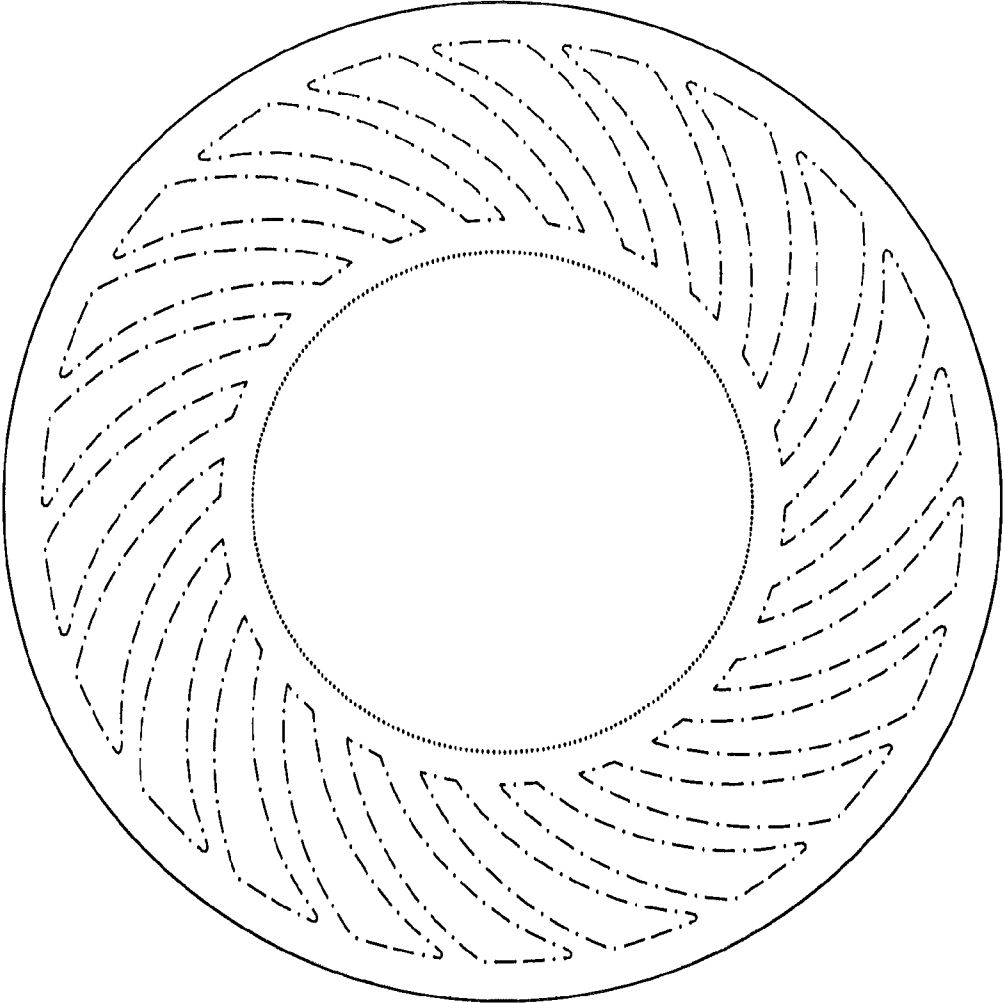

FIG 3

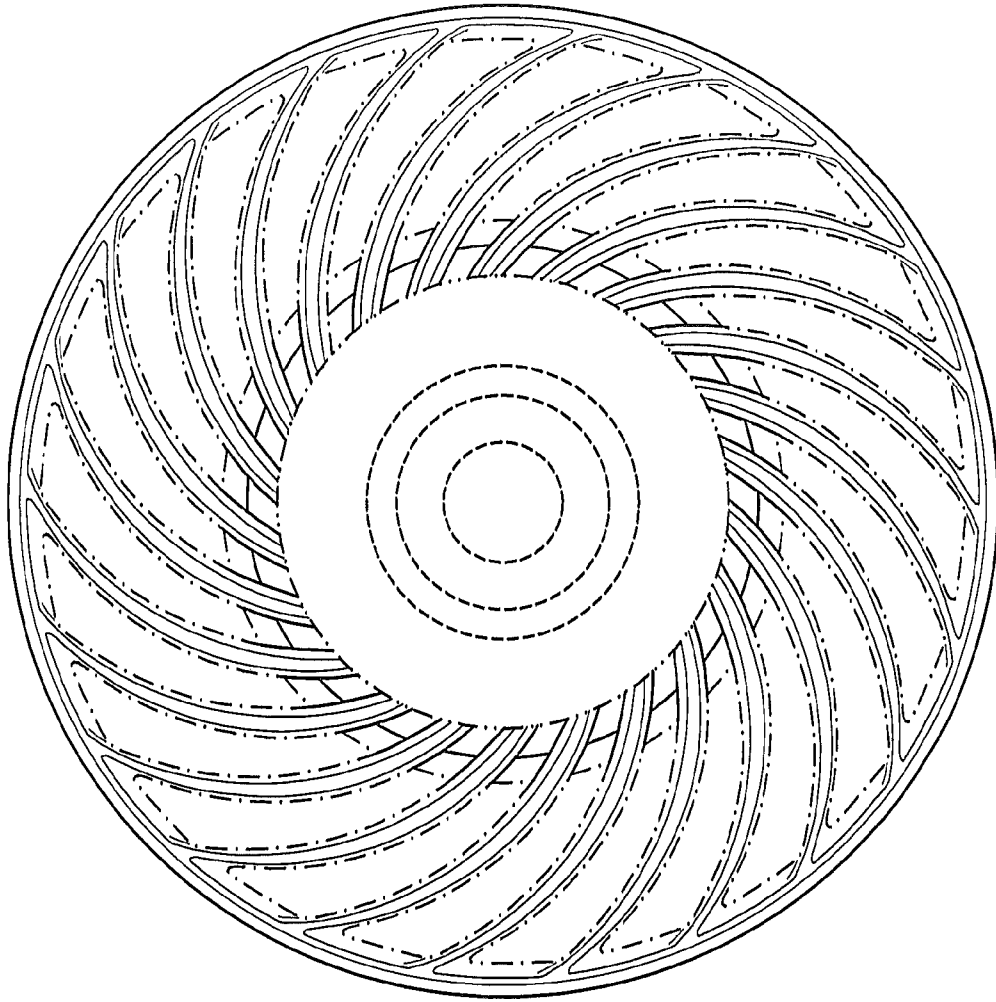

FIG. 4

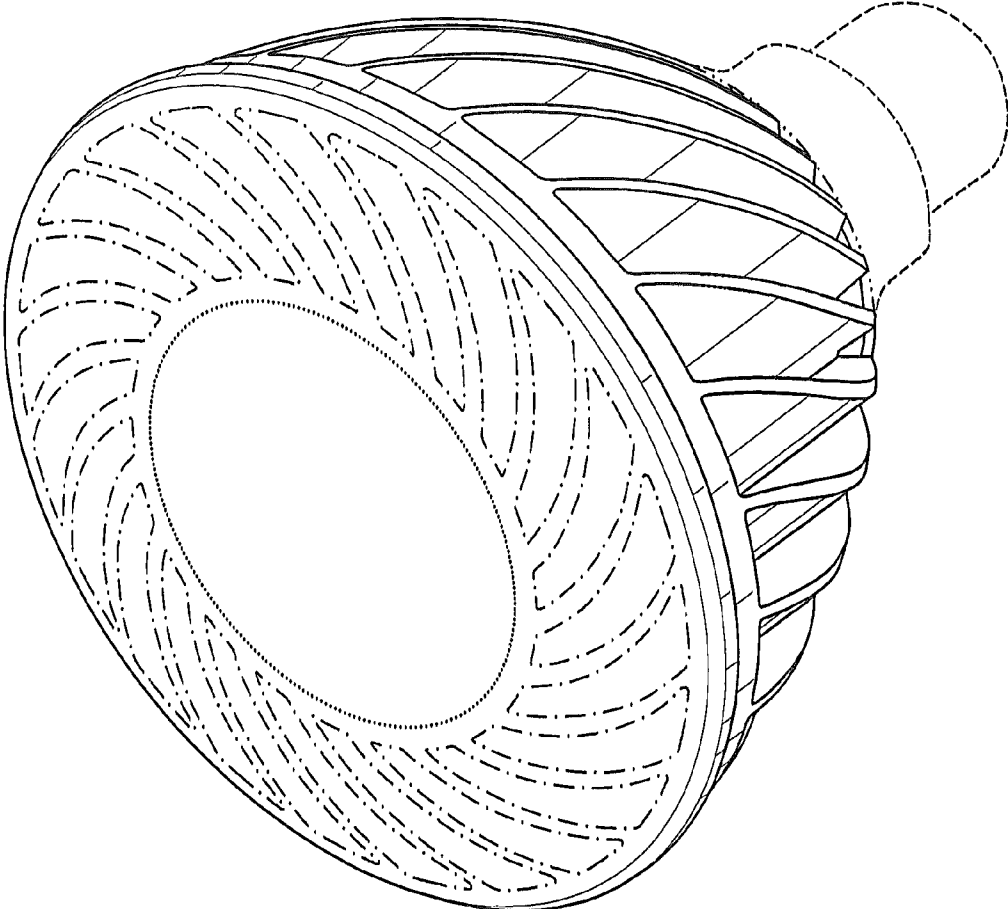

FIG. 5