



US 20130131675A1

(19) **United States**

(12) **Patent Application Publication**

Vasta et al.

(10) **Pub. No.: US 2013/0131675 A1**

(43) **Pub. Date: May 23, 2013**

(54) **FIXATION DEVICE AND MULTIPLE-AXIS JOINT FOR A FIXATION DEVICE**

Publication Classification

(71) Applicant: **AMEI Technologies, Inc.**, Wilmington, DE (US)

(51) **Int. Cl.**
A61B 17/60 (2006.01)

(72) Inventors: **Paul Vasta**, McKinney, TX (US);
Miguel Franco, Addison, TX (US);
Michael Thomas, Van Alstyne, TX (US)

(52) **U.S. Cl.**
CPC *A61B 17/60* (2013.01)
USPC **606/55**

(73) Assignee: **AMEI TECHNOLOGIES, INC.**,
Wilmington, DE (US)

(57) **ABSTRACT**

(21) Appl. No.: **13/745,765**

A fixator system includes an active strut that that can be gradually or acutely adjusted. Adjustments can be made in six degrees of freedom. Embodiments of the active strut can provide for two of the six degrees of freedom being about a first common point of rotation, and another two of the six degrees of freedom being about a second common point of rotation. Embodiments of the fixator can include one or more active struts in combination with one or more passive struts. The passive struts can be rigidly locked or can be unlocked so as to be freely and acutely adjustable while gradual or acute adjustments are made using the one or more active struts.

(22) Filed: **Jan. 19, 2013**

Related U.S. Application Data

(63) Continuation of application No. 12/618,498, filed on Nov. 13, 2009, now Pat. No. 8,377,060.

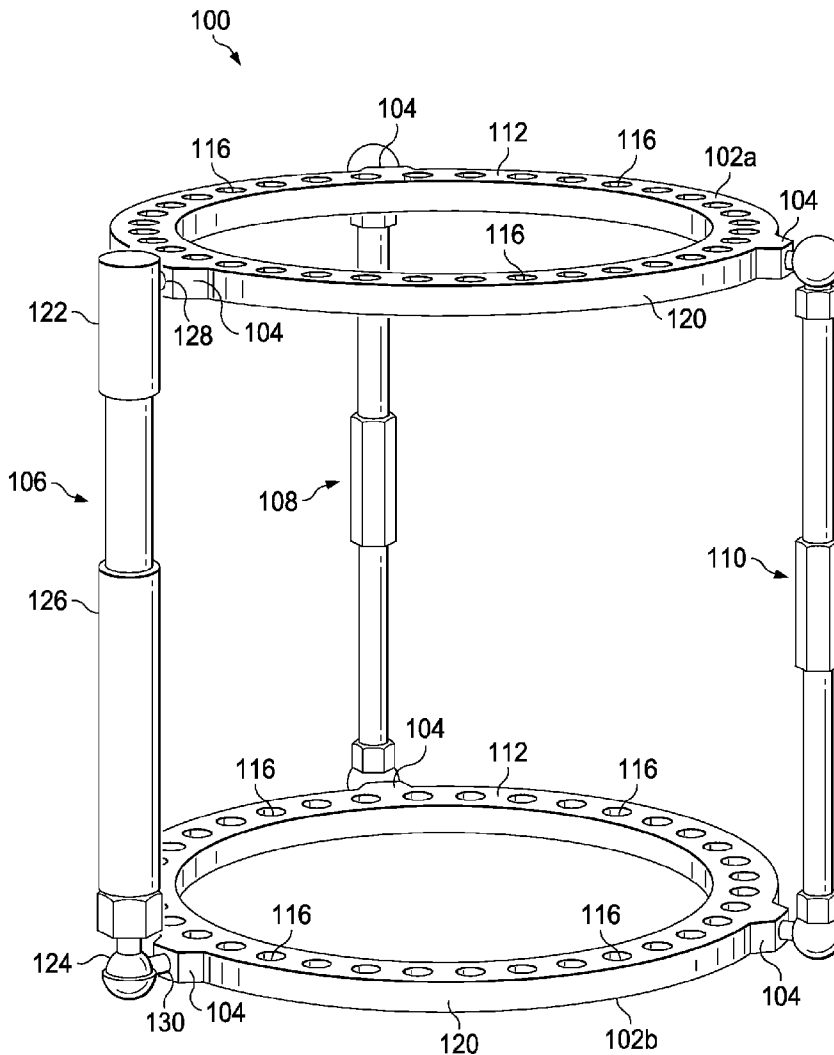

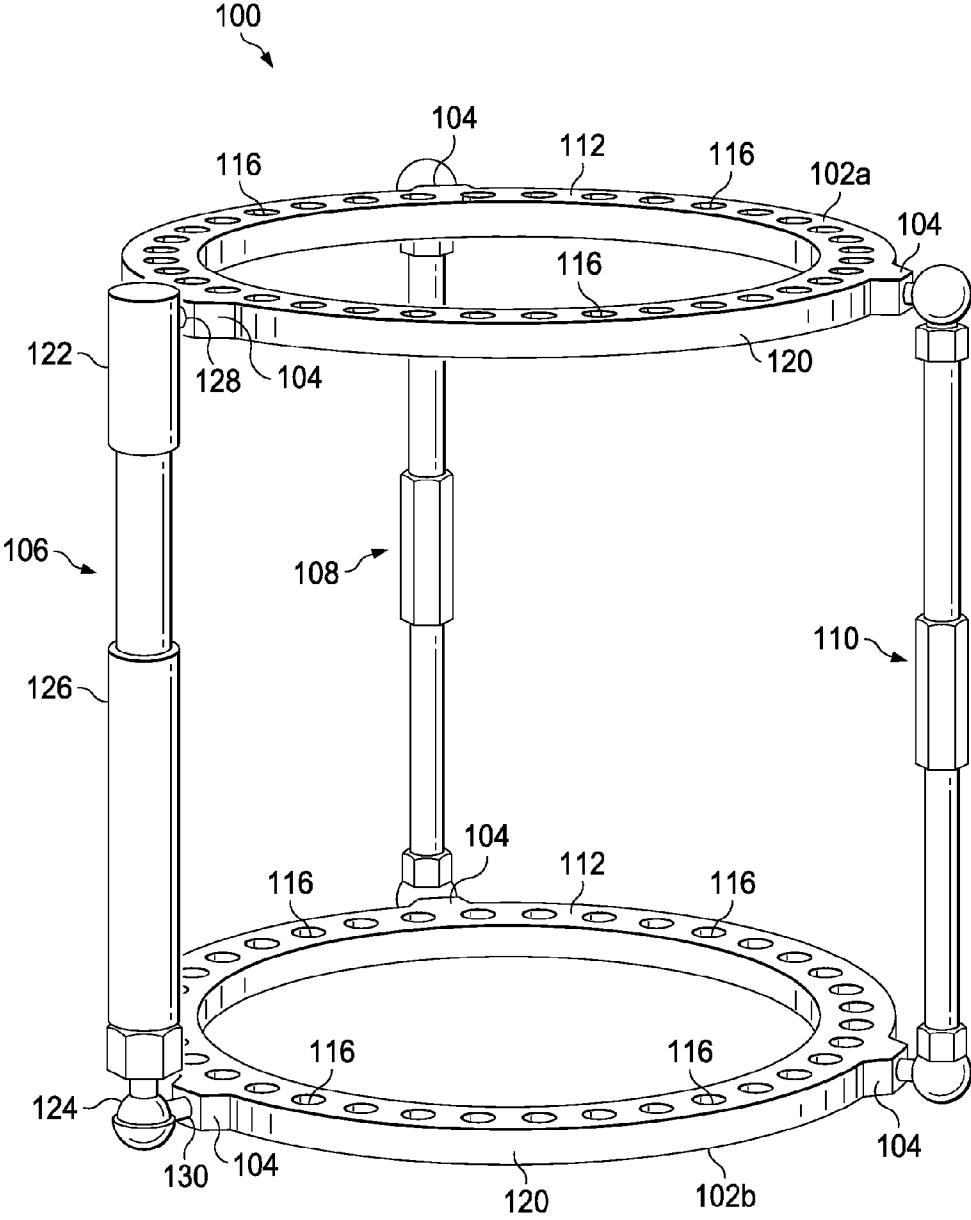

FIG. 1

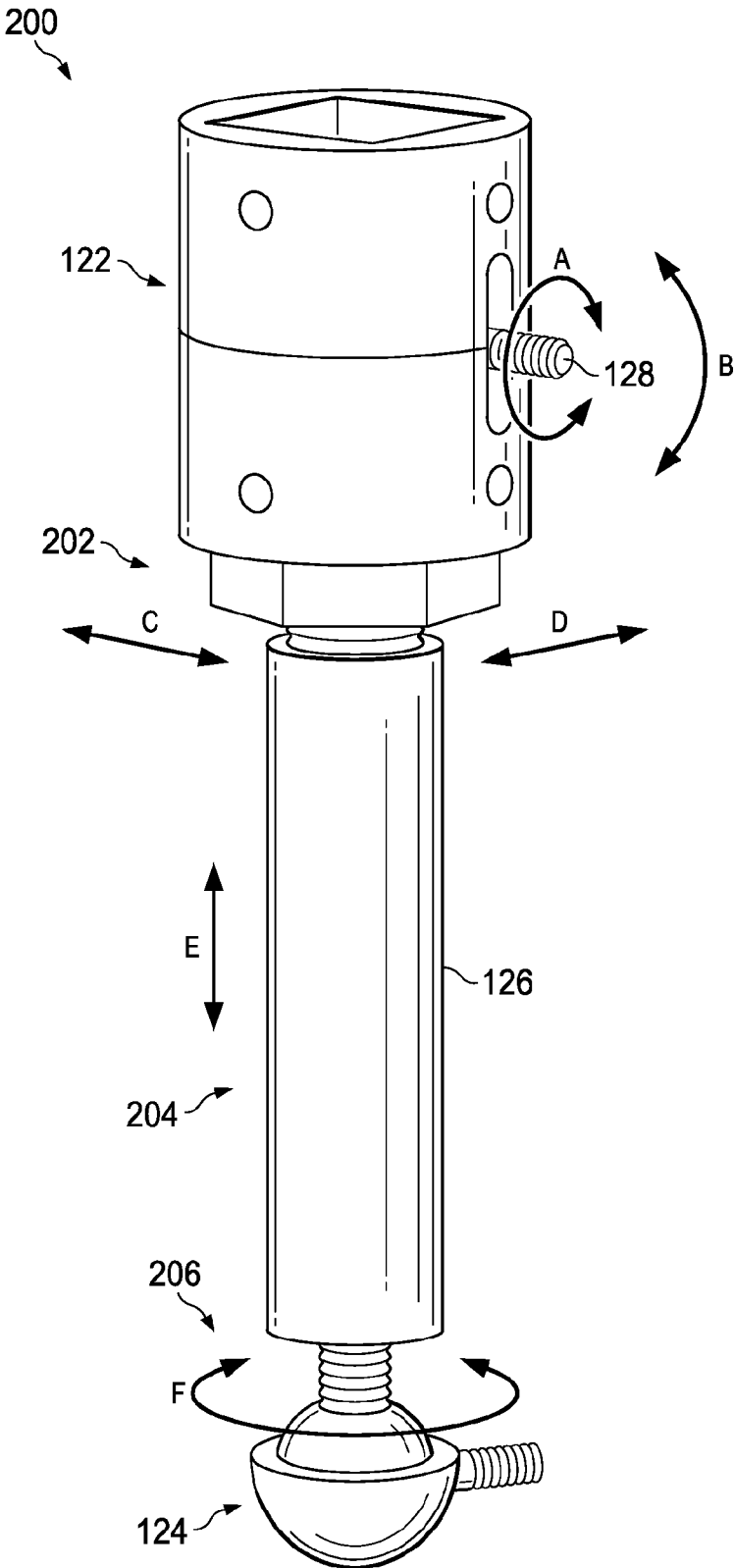

FIG. 2

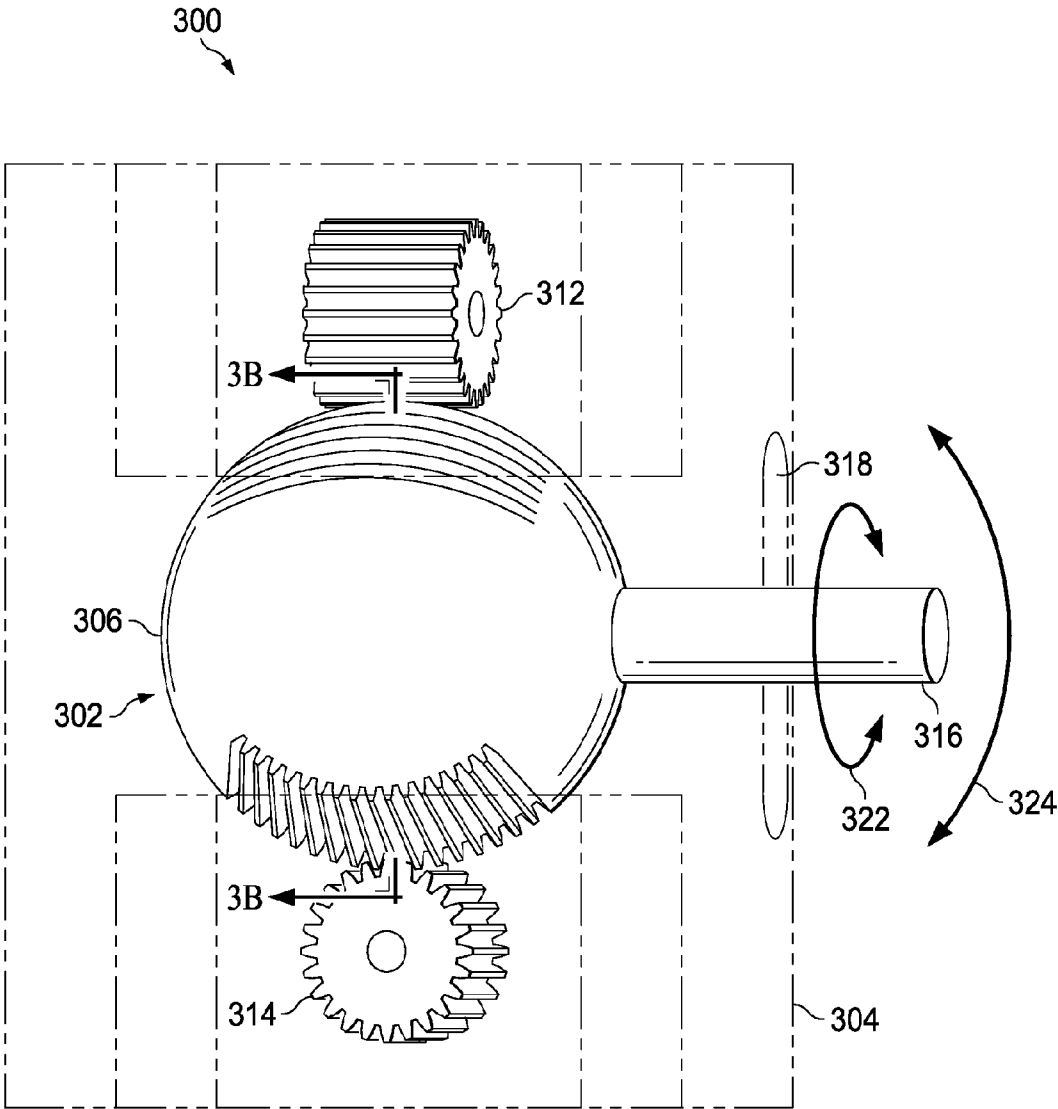

FIG. 3A

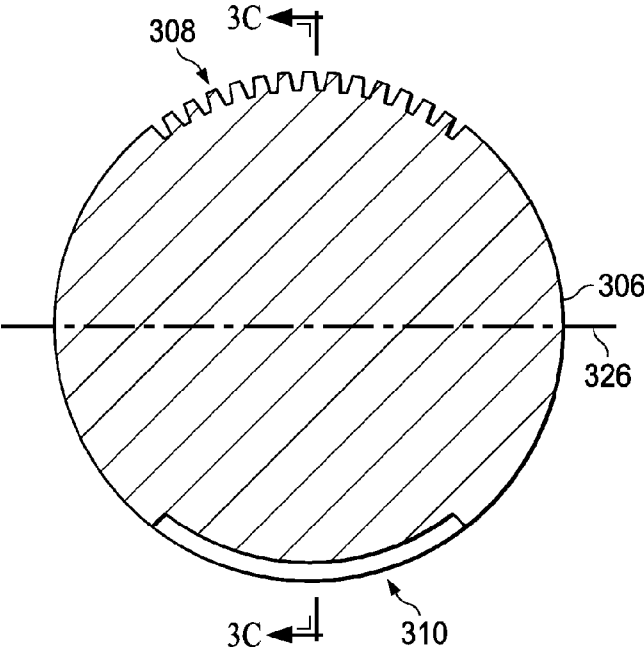

FIG. 3B

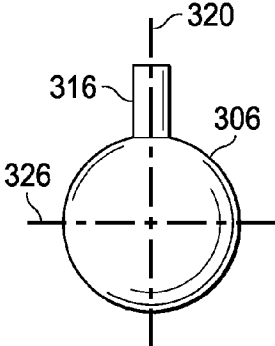

FIG. 3D

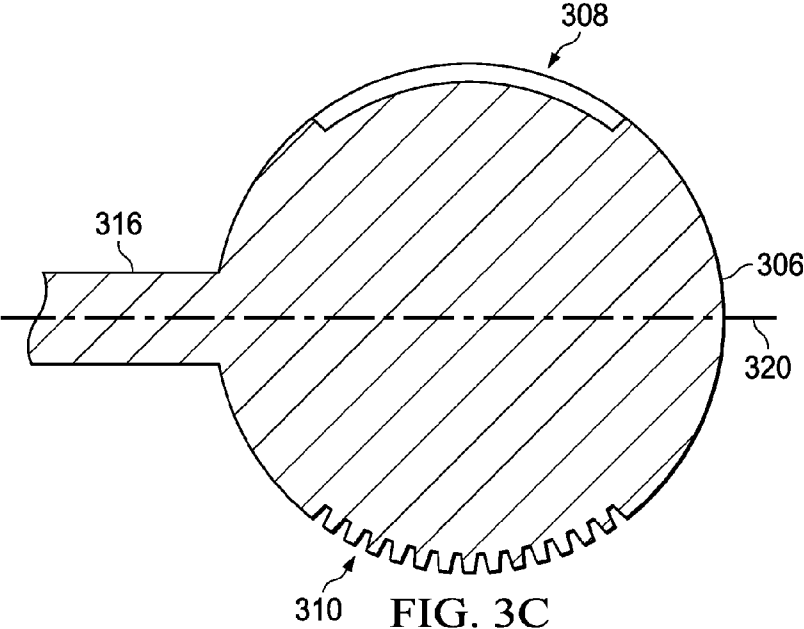

FIG. 3C

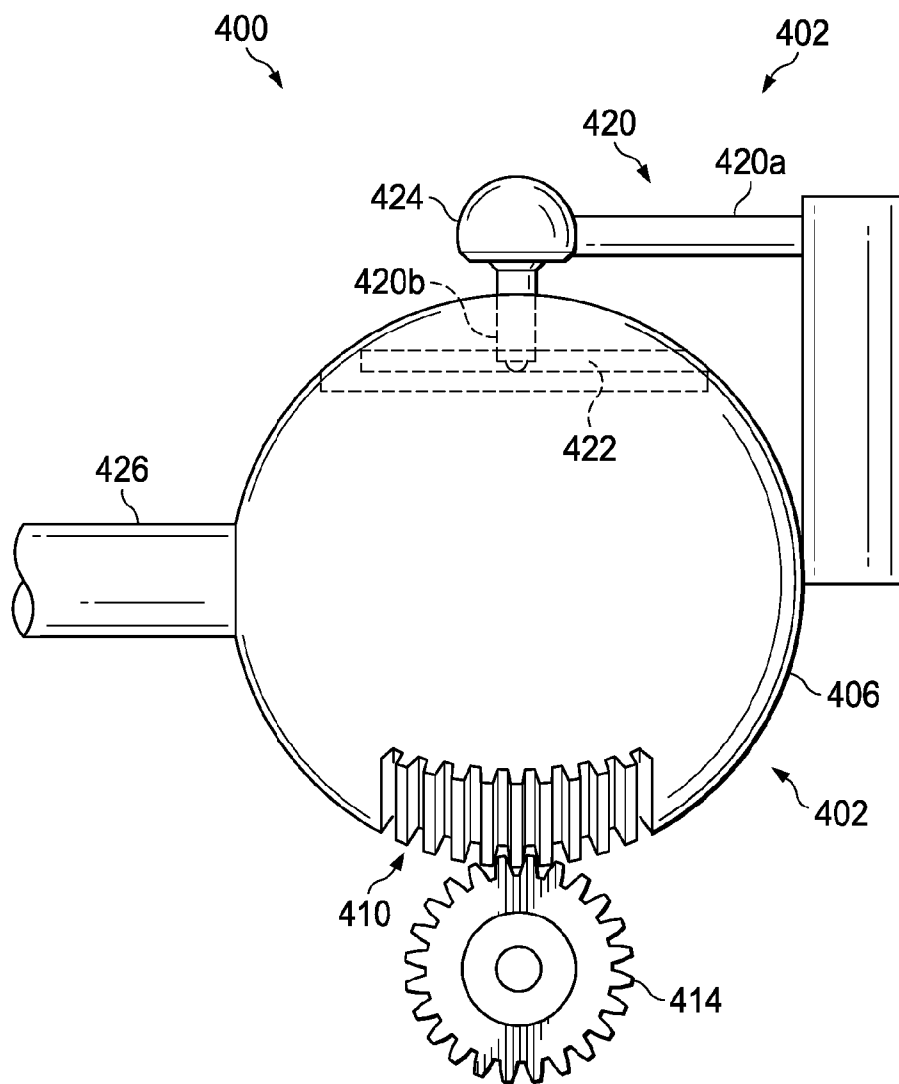

FIG. 4A

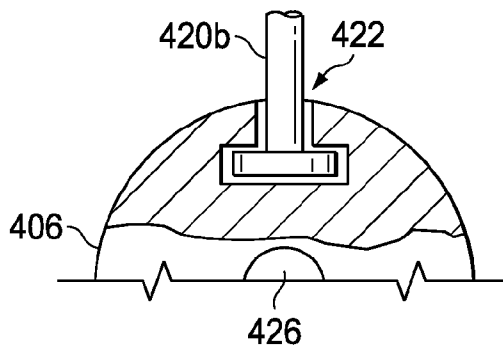

FIG. 4B

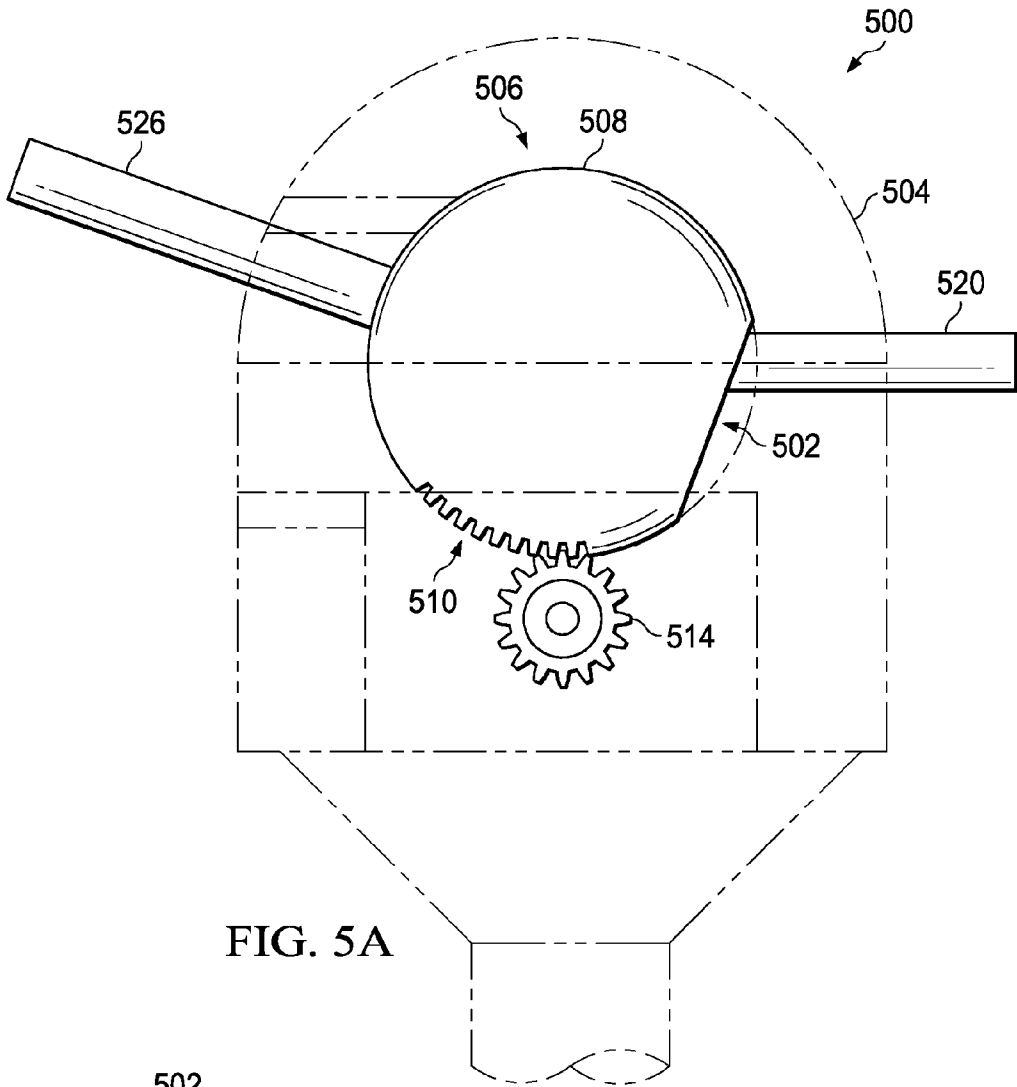

FIG. 5A

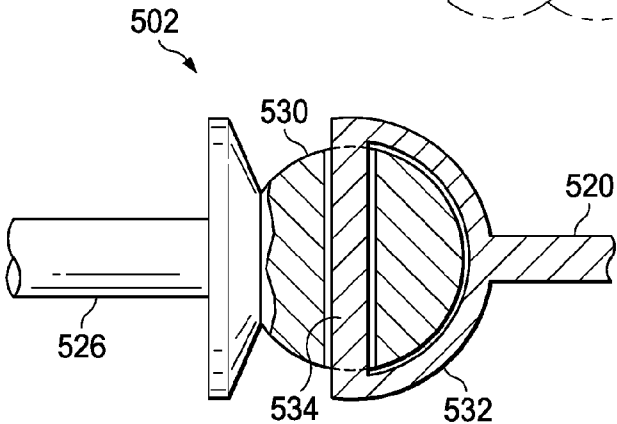

FIG. 5C

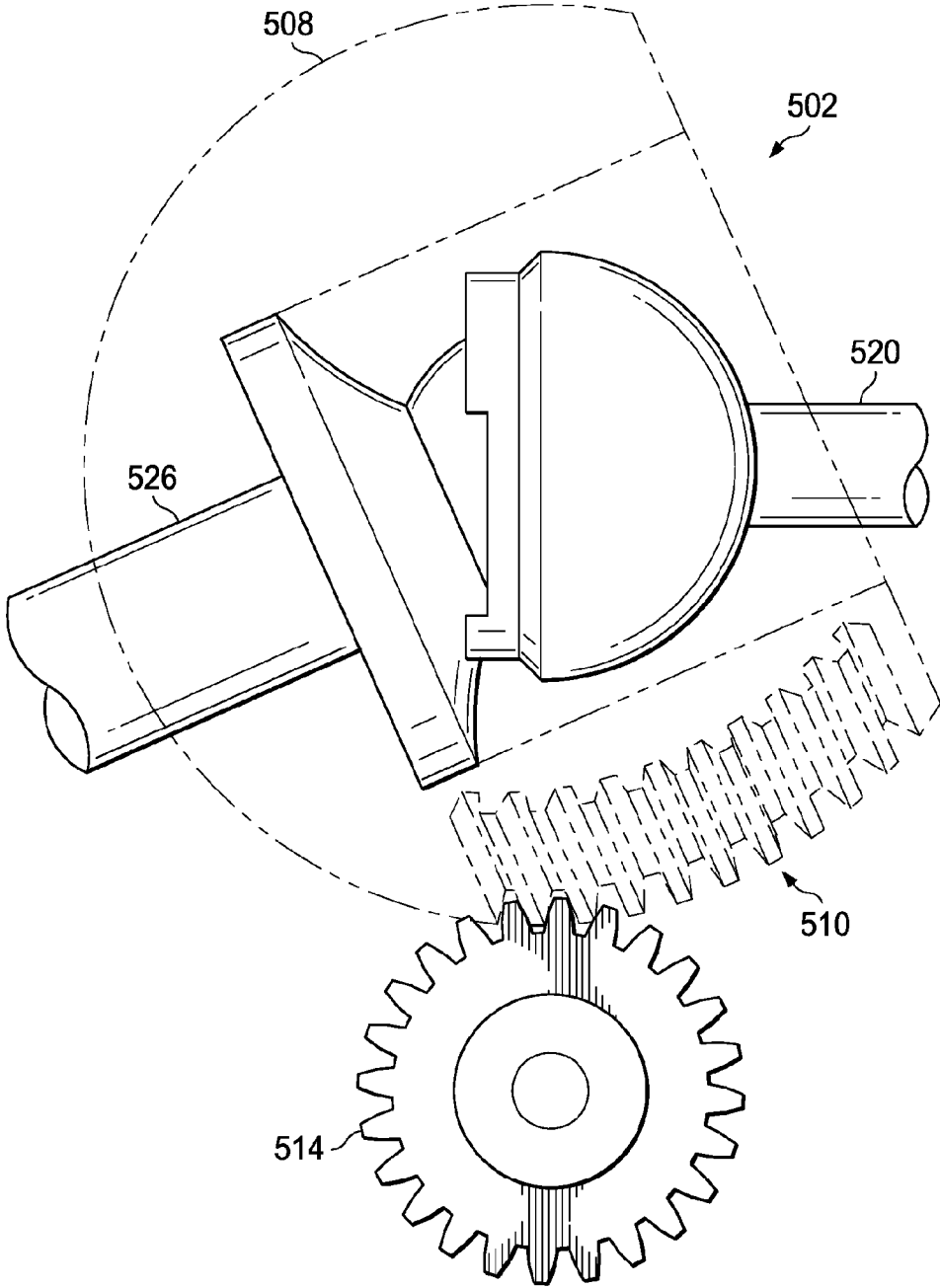

FIG. 5B

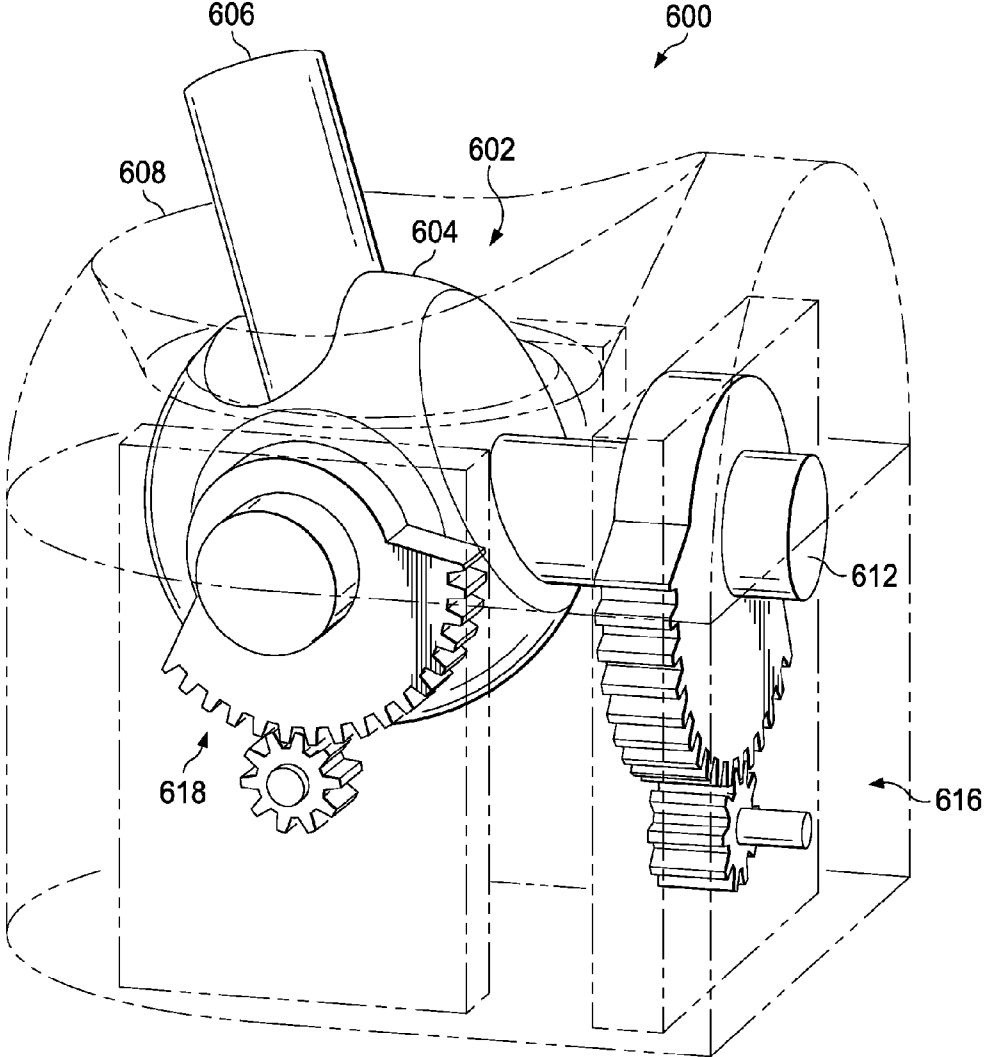

FIG. 6A

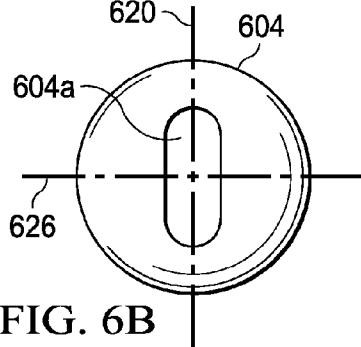

FIG. 6B

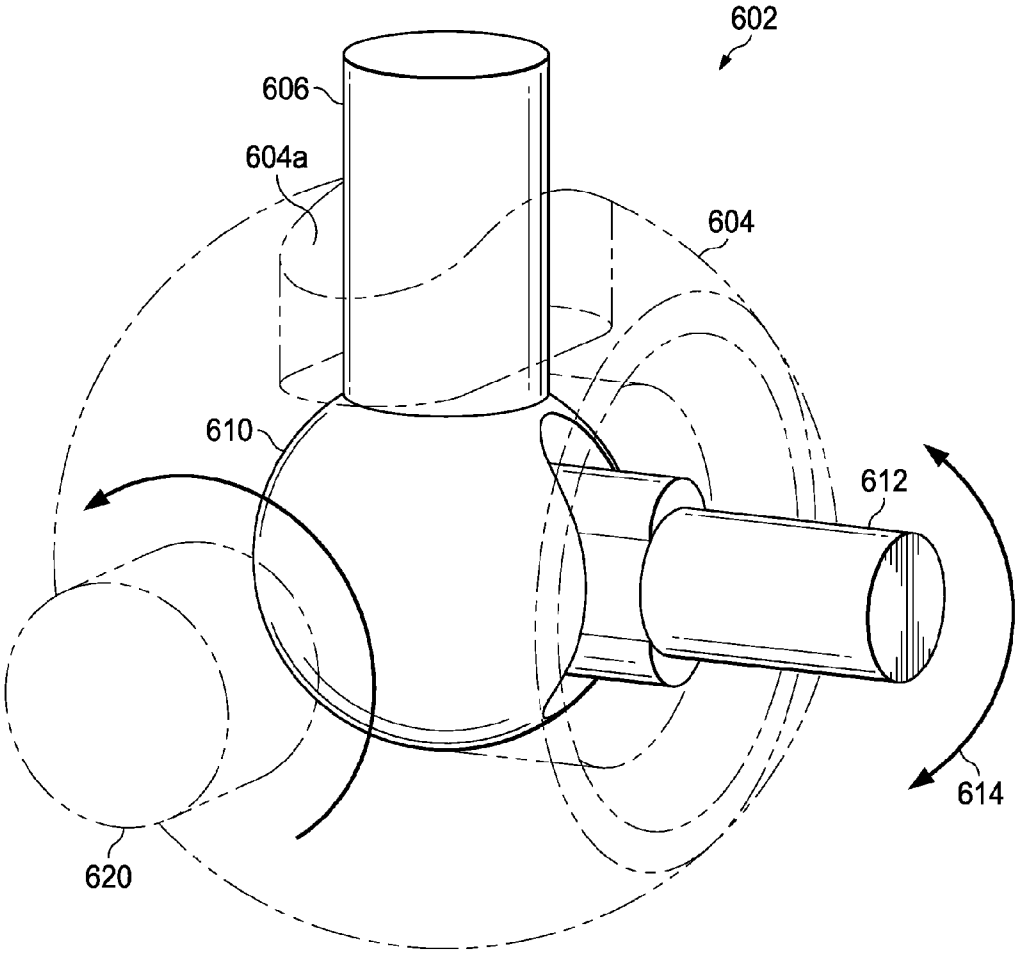

FIG. 7

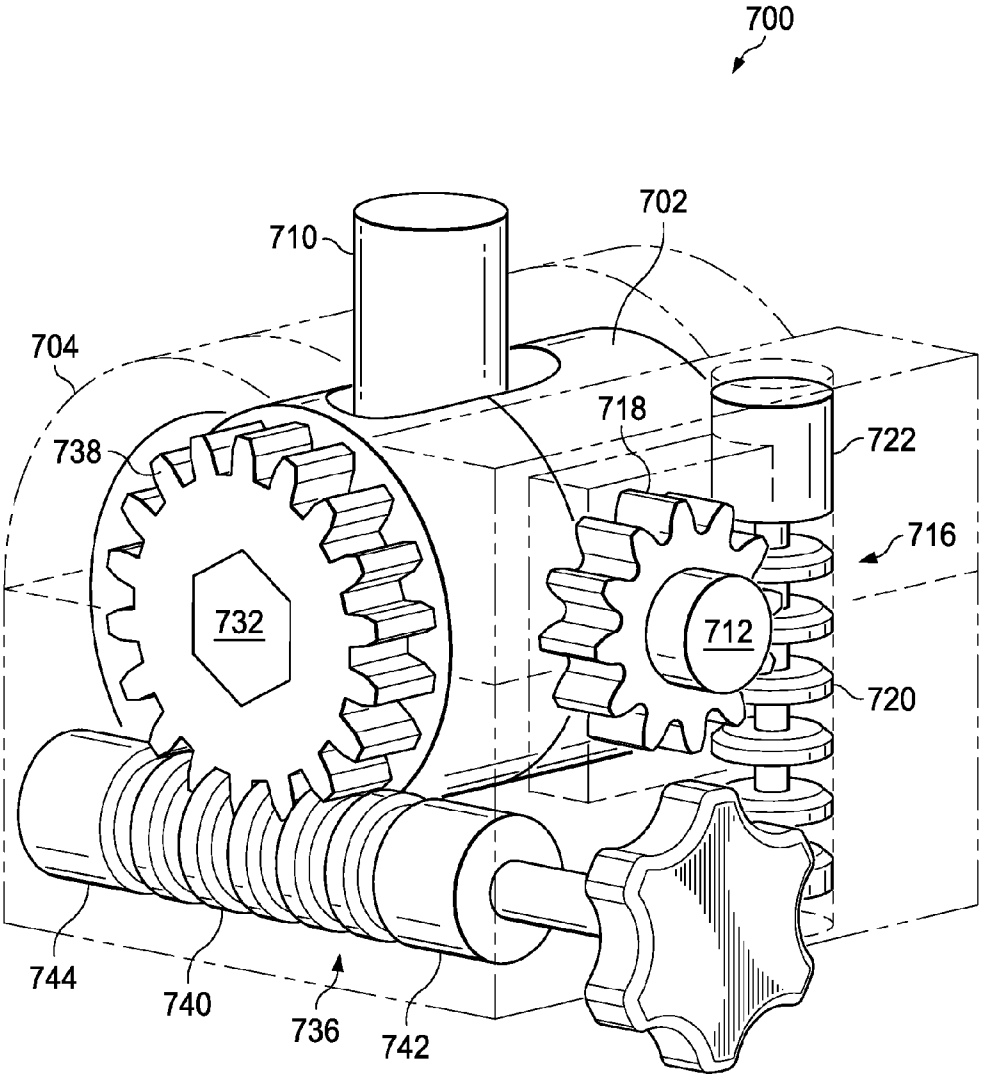

FIG. 8

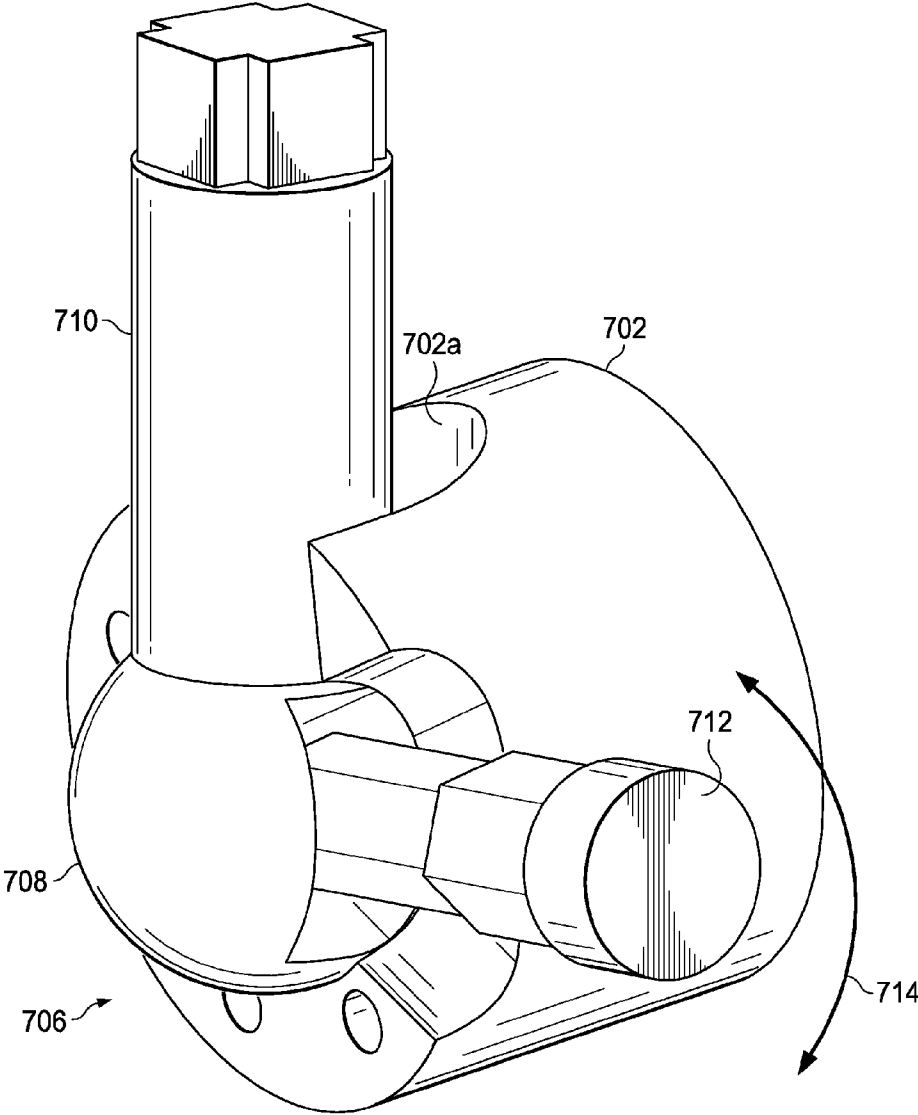

FIG. 9

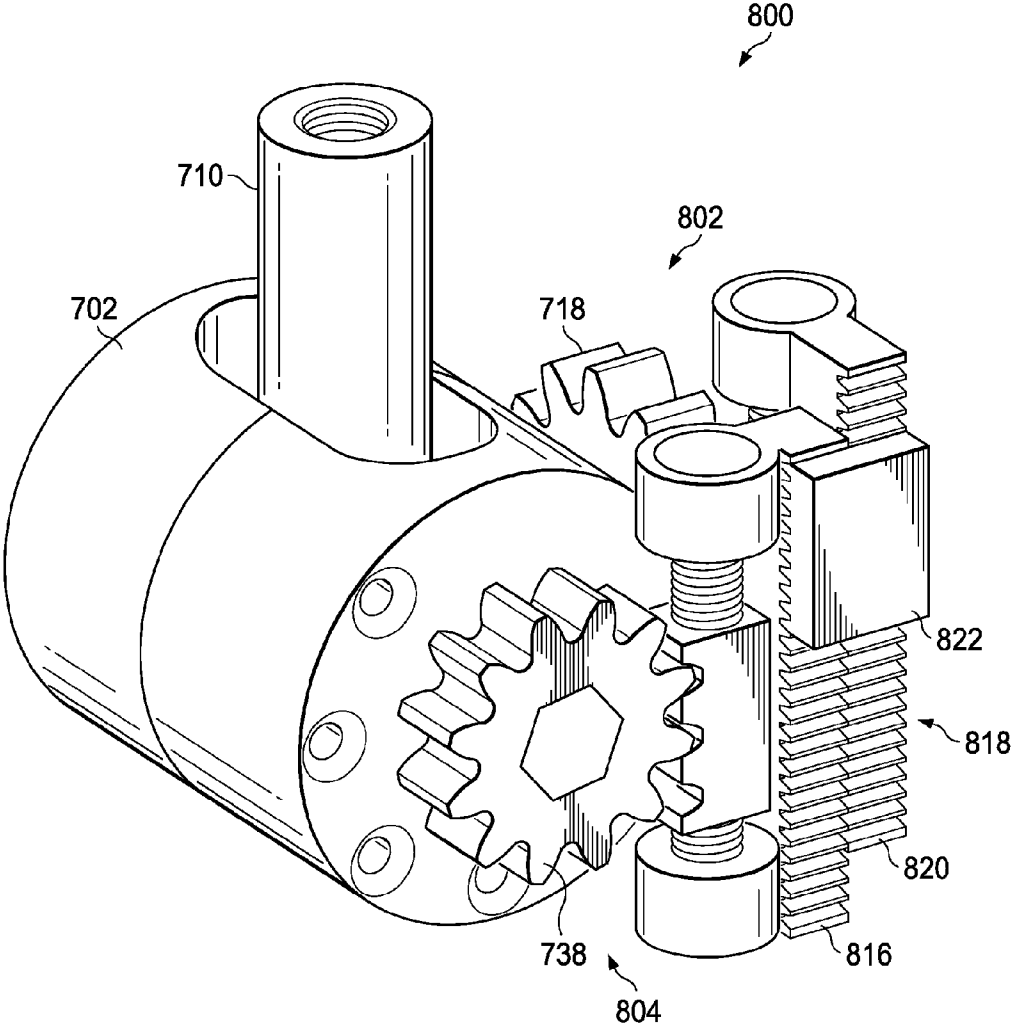

FIG. 10A

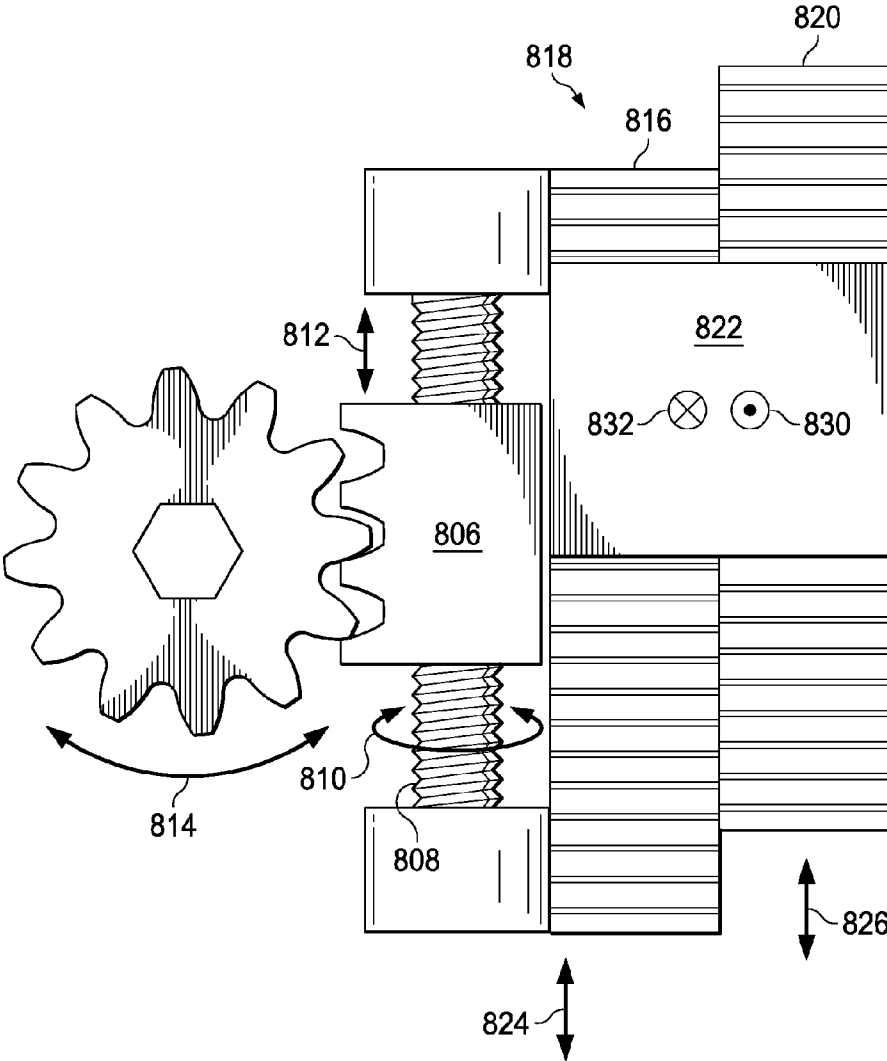

FIG. 10B

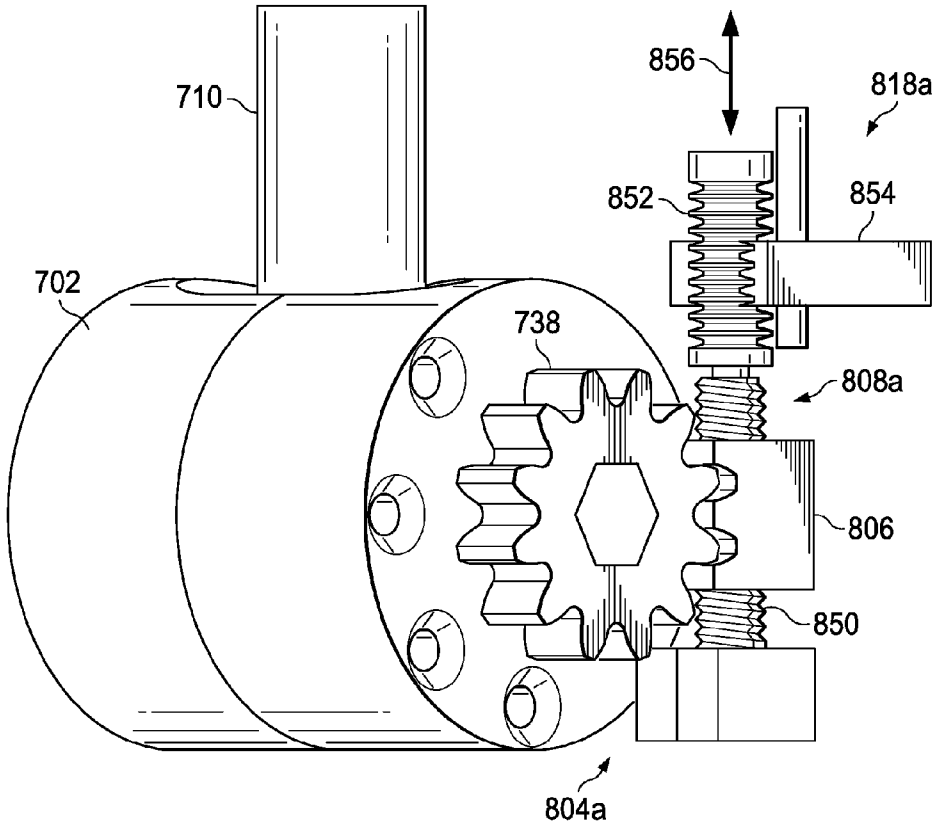

FIG. 11

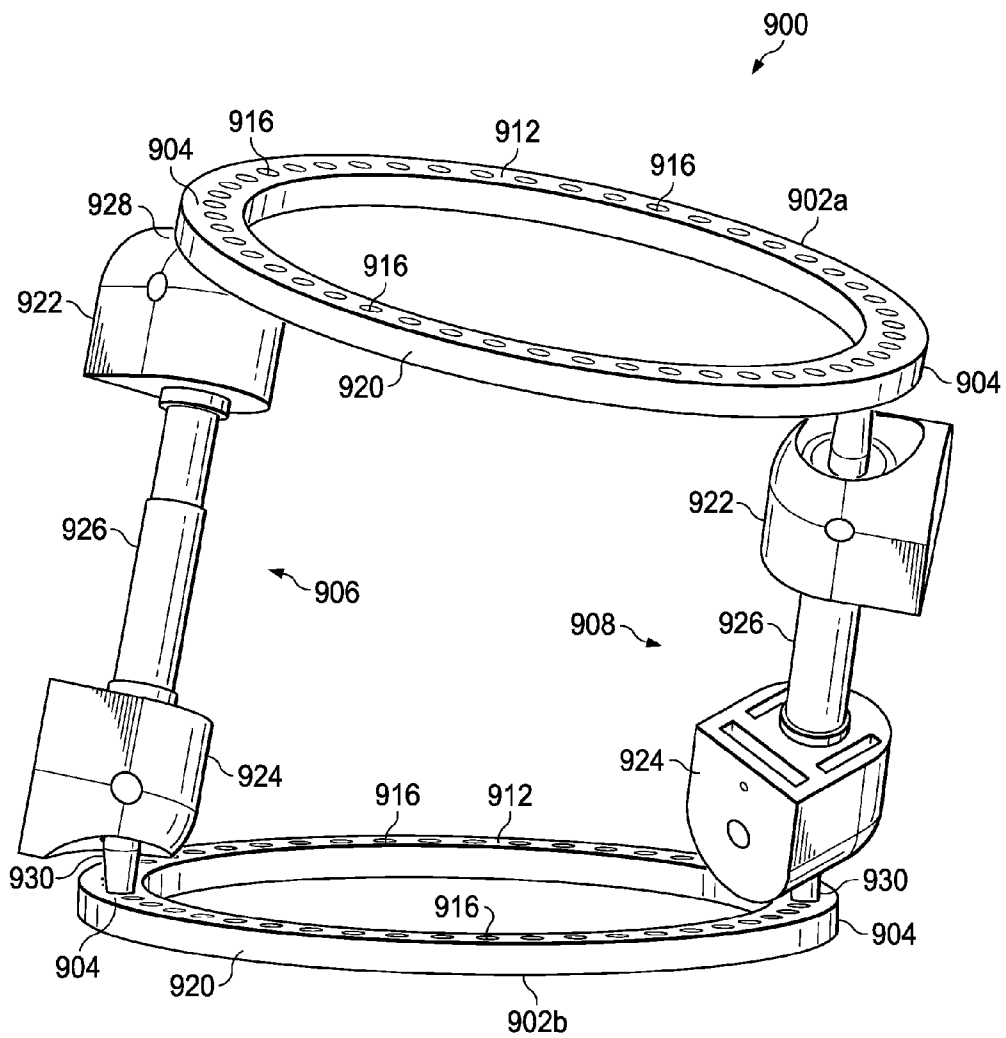

FIG. 12

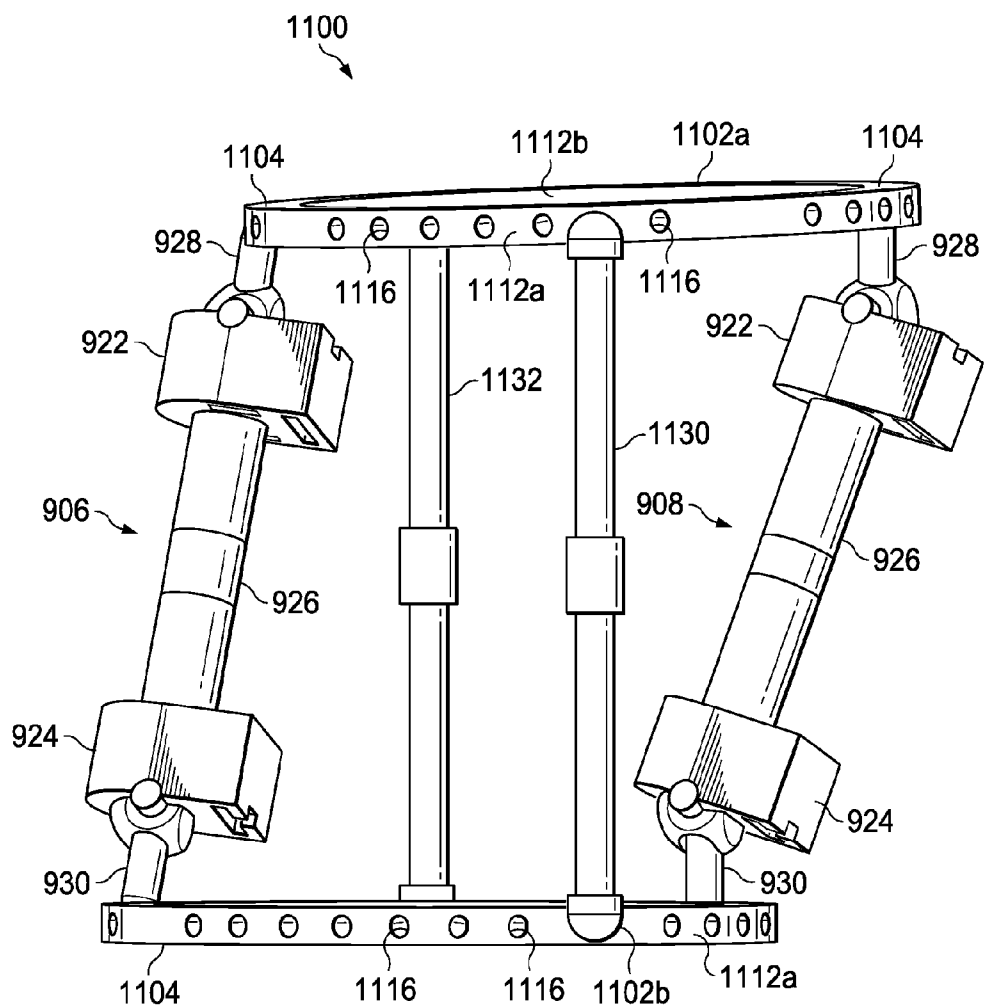

FIG. 13

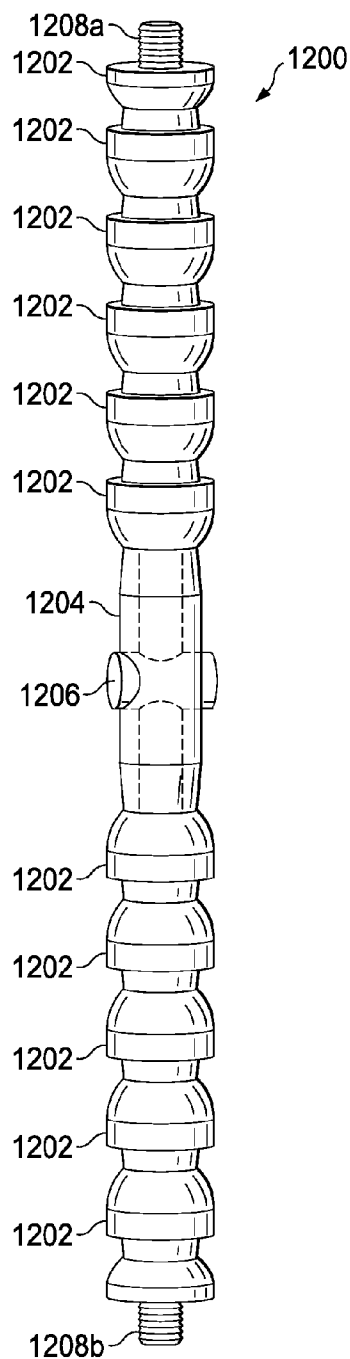

FIG. 14A

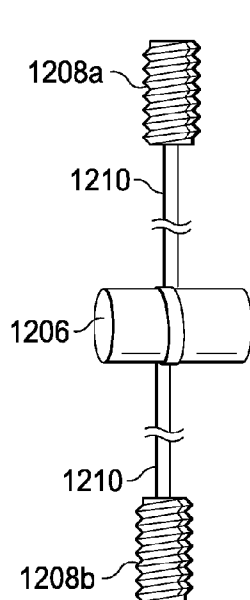

FIG. 14B

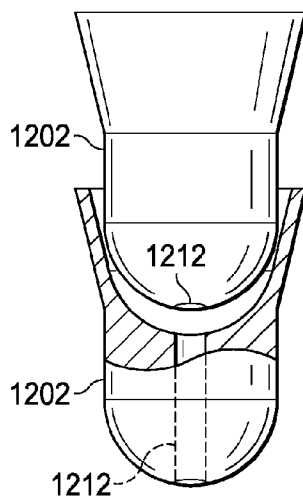

FIG. 14C

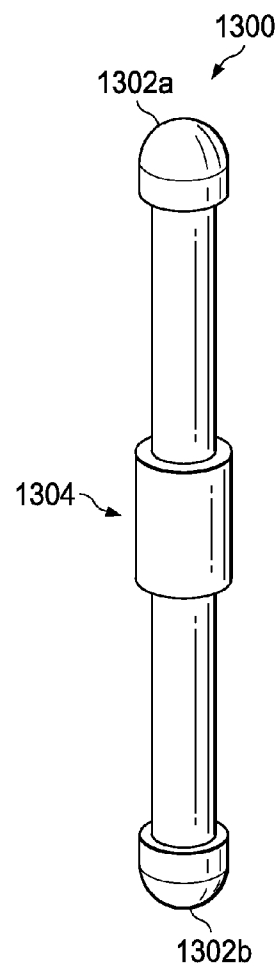

FIG. 15

FIXATION DEVICE AND MULTIPLE-AXIS JOINT FOR A FIXATION DEVICE

CROSS-REFERENCE TO RELATED APPLICATIONS

[0001] This is a continuation application of U.S. application Ser. No. 12/618,498, which was filed on Nov. 13, 2009 and is incorporated herein by reference.

TECHNICAL FIELD

[0002] The present disclosure relates in general to medical device technology, and more specifically to external fixation devices and to drive systems that allow precise control for positioning and locking such fixation devices.

BACKGROUND

[0003] Without limiting the scope of the present disclosure, its background is described in connection with external fixation devices. Generally, external fixation devices are commonly used on both the upper and lower limbs for both adults and children in a variety of surgical procedures including limb lengthening, deformity correction and treatment of fractures, mal-unions, non-unions and bone defects.

[0004] One common external fixation device is known as the Ilizarov Apparatus. The Ilizarov external fixation procedure involves a rigid framework consisting of several rings or arches that are placed externally around the limb and attached to injured (e.g., due to fracture) or surgically separated (e.g., for limb lengthening and deformity correction) bone segments using special bone fasteners (wires and pins) inserted into the bone segment and connected to the related section of the external rigid framework. The opposite rings of the rigid framework are connected by either threaded or telescopic connection rods or by assembled uni-planar or multi-planar angular hinges, which allow the surgeon to adjust the relative position of the rings to each other longitudinally or angularly over a period of time. This allows new bone to gradually form in the gap between bone segments created by this distraction technique. Once the desired position of bone segments is achieved over the course of time (e.g., 2-6 weeks), the external apparatus is stabilized into a fixed position and left on the bone segments until the fracture is healed or newly formed bone is completely or substantially mineralized, which could take up to an additional 3-6 months, depending on the nature of pathology and degree of deformity.

[0005] Another common external fixation device is a Taylor Spatial Frame as described in U.S. Pat. Nos. 6,030,386, 5,891,143, and 5,776,132. The Taylor Spatial Frame is a hexapod type of device based on a Stewart platform but shares many components and features of the Ilizarov apparatus. The Taylor Spatial Frame consists of two external fixator rings attached to bone segments by wires or half pins and connected together by six struts that may be lengthened or shortened as necessary. Adjustment of strut lengths allows manipulation of the bone segments in 6 axes (e.g., lengthening/shortening, external/internal rotation, anterior/posterior horizontal translation, medial/lateral horizontal translation, anterior/posterior angular translation, and medial/lateral angular translation) to correct linear, angular and rotational deformities simultaneously.

[0006] The fixation device would usually be placed on the affected patient by medical personnel in such a way as to align the affected body part during the healing process, holding the

affected body part in the proper position for treatment. Since applications of such devices can include a wide variety of deformities, body sites, and surgical implementations, there is a need for fixation devices that can initially be acutely adjusted in order to accommodate such variabilities and subsequently maintain the affected body part in one desirable position. Moreover, a typical treatment regimen requires frequent adjustments to be performed by the patient and/or during repeated visits to medical professionals so that the fixation device could be periodically and gradually adjusted, providing the desired orientation to the affected body part and setting the proper amount of stretching and support for healing. Accordingly, there is also a need for fixation devices that allow for gradual adjustments after the fractured body part is substantially maintained in one position.

[0007] Thus, there is a need for an improved fixation device that will allow medical professionals to make effective, calibrated adjustments to the positioning of the injured body part.

BRIEF DESCRIPTION OF THE DRAWINGS

[0008] For a more complete understanding of the features and advantages of the present disclosure, reference is now made to the detailed description along with the accompanying figures and in which:

[0009] FIG. 1 is a perspective view of an external fixator ring system according to one embodiment of the present disclosure that includes an active strut in combination with a plurality of passive struts;

[0010] FIG. 2 is a perspective view of a fixator assembly according to one embodiment of the present disclosure;

[0011] FIG. 3A is a perspective view of a first embodiment of a multiple-axis joint according to the present disclosure;

[0012] FIG. 3B is a cross-sectional view of a portion of the first embodiment of the multiple-axis joint taken along section lines 3B-3B shown in FIG. 3A;

[0013] FIG. 3C is a cross-sectional view of a portion of the first embodiment of the multiple-axis joint taken along section lines 3C-3C shown in FIG. 3B;

[0014] FIG. 3D is a top view of a portion of the first embodiment of the multiple-axis joint shown in FIG. 3B;

[0015] FIG. 4A is a perspective view of a second embodiment of a multiple-axis joint according to the present disclosure;

[0016] FIG. 4B is a partially-sectioned view of a portion of the joint shown in FIG. 4A;

[0017] FIG. 5A is a perspective view of a third embodiment of a multiple-axis joint according to the present disclosure;

[0018] FIG. 5B is a view of an internal joint of the third embodiment of the multiple-axis joint shown in FIG. 5A;

[0019] FIG. 5C is a partially-sectioned view of the internal joint shown in FIG. 5B;

[0020] FIG. 6A is a perspective view of a fourth embodiment of a multiple-axis joint according to the present disclosure;

[0021] FIG. 6B is a top view of a portion of the joint shown in FIG. 6A;

[0022] FIG. 7 is a view of an internal joint of the fourth embodiment of the multiple-axis joint shown in FIG. 6;

[0023] FIG. 8 is a perspective view of a fifth embodiment of a multiple-axis joint according to the present disclosure;

[0024] FIG. 9 is a view of an internal joint of the fifth embodiment of the multiple-axis joint shown in FIG. 8;

[0025] FIG. 10A is a perspective view of a sixth embodiment of a multiple-axis joint according to the present disclosure;

[0026] FIG. 10B is a view of a gear assembly and acute adjustment assembly of the sixth embodiment of the multiple-axis joint shown in FIG. 10A;

[0027] FIG. 11 is a view of an alternative gear assembly and acute adjustment assembly of the sixth embodiment of the multiple-axis joint shown in FIGS. 10A and 10B;

[0028] FIG. 12 is a perspective view of a first alternative embodiment of an external fixator ring system according to the present disclosure that includes a plurality of active struts;

[0029] FIG. 13 is a perspective view of a second alternative embodiment of an external fixator ring system according to the present disclosure that includes a plurality of active struts in combination with a plurality of passive struts;

[0030] FIG. 14A is a perspective view of an embodiment of a passive support strut that can be used with external fixator ring systems of the present disclosure;

[0031] FIG. 14B is a perspective view of internal elements of the passive support strut shown in FIG. 14A;

[0032] FIG. 14C is a partially-sectioned view of elements of the passive support strut shown in FIG. 14B; and

[0033] FIG. 15 is a perspective view of another embodiment of a passive support strut that can be used with external fixator ring systems of the present disclosure.

DETAILED DESCRIPTION

[0034] While the making and using of various embodiments of the multiple-axis joint according to the present disclosure are discussed in detail below, it should be appreciated that the present application provides many applicable inventive concepts that can be embodied in a wide variety of specific contexts. Without limiting the scope of the present disclosure, the multiple-axis joint is described in connection with external fixation devices. However, the multiple-axis joint can be used with other devices. The specific embodiments discussed herein are merely illustrative of specific ways to make and use the multiple-axis joint disclosed herein and do not delimit the scope of the application, and their usage does not delimit the application, except as outlined in the claims.

[0035] FIG. 1 is a perspective view of an external fixator ring system 100. The fixator ring system 100 includes a first fixator ring 102a and a second fixator ring 102b, which serve as examples of fixator base elements. The fixator rings 102a and 102b both include a plurality of strut mounting positions 104. The fixator rings 102a and 102b are connected by a plurality of connection struts 106, 108, and 110, which are attached to the fixator rings 102a and 102b at the strut mounting positions 104.

[0036] Strut 106 is an active strut, whereas struts 108 and 110 are passive struts. All of the struts 106, 108, and 110 are preferably capable of being locked into a rigid state such that the rings 102a and 102b are fixed relative to each other, and unlocked into a free state such that acute adjustments can be made to the relative positions of the rings 102a and 102b. Such acute adjustments are desirable at certain times, for example during the initial placement of the fixator ring system 100 onto an injured limb. The passive struts 108 and 110 are limited to being either locked into a passive locked state, which is a non-adjustable rigid state, or being unlocked into a freely adjustable state. The active strut 106 is capable of being locked into an active locked state, which is a rigid and adjust-

able state, or being unlocked into a freely adjustable state. In some embodiments, the active strut 106 can further be locked into a passive locked state so that it is even locked from being adjustable. Thus, the active strut 106 differs from the passive struts 108 and 110 in that the active strut 106 is configured for an active locked state wherein the active strut 106 is capable of being controllably articulated for making fine or gradual adjustments to the relative positions of the rings 102a and 102b with little or no loss in rigidity while such adjustments are made. Such fine or gradual adjustments between the rings 102a and 102b are desirable after the initial placement of the fixator ring system 100, for example as part of a treatment plan for an injured limb that might require periodic gradual adjustments. Thus, the fixator ring system 100 disclosed herein includes a combination of active and passive struts 106, 108, and 110. While the fixator ring system 100 includes one active strut 106 and two passive struts 108 and 110, alternative embodiments, including those described herein, can include more than one active strut and more or fewer than two passive struts.

[0037] The first fixator ring 102a includes a top surface 112 and an opposing bottom surface (not shown). The top surface 112 includes numerous holes 116 that extend through the top surface 112 to the bottom surface (not shown). The holes 116 may be used for attachment of wire and half-pin fixation elements (bolts), threaded or telescopic connection rods, plates, posts or other device connection elements to the first fixator ring 102a. In some embodiments, the outer side surface 120 of the first fixator ring 102a can include numerous threaded apertures (not shown) that provide additional attachment points for struts or other connection elements (not shown). The second fixator ring 102b can be identical or similar to the first fixator ring 102a.

[0038] Although the shape of the fixator rings 102a and 102b as shown in FIG. 1 is substantially circular, the shape of the fixator rings 102a and 102b can vary to accommodate the physical contour of various body parts to which the fixation system 100 would be attached. For example, the fixator rings 102a and 102b can be fixator base elements that are configured to have an oval shape, D-shape, U-shape, C-shape, a polygon, or other irregular shapes. In some exemplary embodiments, an elliptical fixator ring (not shown) may be particularly advantageous. The insertion of pins or wires into a patient's limb can cause the surrounding tissue to swell unevenly, and in such a case, an elliptical fixator ring can accommodate the uneven swelling better than a circular ring can. The fixator rings 102a and 102b may be fixator base elements that form a complete ring (full ring) or a segment or portion of a ring (e.g., half ring, 1/3 ring, 1/4 ring, 3/8 ring, 5/8 ring, 2/3 ring, 3/4 ring, and other) that is either used alone or joined with other segments or portions of the ring to form a fixator ring (not shown). The fixator rings 102a and 102b may be fixator base elements that are constructed of any material that provides the structural rigidity necessary for fixation such as metal, alloy, carbon fiber, plastic, ceramic and so forth. Moreover, the material comprising the rings 102a and 102b may be radiotranslucent.

[0039] The strut 106 is an active strut that is adjustable in six degrees of freedom. The strut 106 includes a first joint 122 and a second joint 124 connected by a center portion 126. The first joint 122 includes a first driven element 128 that connects to one of the strut mounting positions 104 of the first fixator ring 102a. The second joint 124 includes a second driven element 130 that connects to one of the strut mounting posi-

tions **104** of the second fixator ring **102a**. As discussed in greater detail below, the driven elements **128** and **130** can each be articulated in two degrees of freedom. For example, depending on the embodiment, the driven element **128** can be angularly and/or rotationally repositioned relative to the center portion **126** of the strut **106** and/or the driven element **130** can be angularly and/or rotationally repositioned relative to the center portion **126** of the strut **106**. The center portion **126** can also be lengthwise adjustable and/or translationally and/or rotationally adjustable relative to one or both of the first and second joints **122** and **124**. Such embodiments can allow for multiple degrees of freedom in repositioning the first fixator ring **102a** relative to the second fixator ring **102b**.

[0040] FIG. 2 is a perspective view of a fixator assembly **200**. The fixator assembly **200** can be used as the strut **106** of the fixator ring system **100**, or can be used as a monolateral fixator. The fixator assembly **200** includes the first joint **122** and the second joint **124** as described above. The first and second joints **122** and **124** are connected by the center portion **126**. The first joint **122** includes the driven element **128** that can be configured for connection to another fixator base element, such as the fixator ring **102a** or **102b**, or another type of fixator base element. As discussed in greater detail below, the driven element **128** can be angularly and/or rotationally repositioned relative to the center portion **126** of the fixator assembly **200**, as illustrated by arrows A and B.

[0041] The fixator assembly **200** can include various other adjustable elements in order to allow for six degrees of freedom. For example, the fixator assembly **200** can include internal worm gears at adjustment position **202** for allowing adjustments to be made in directions indicated by arrows C and D; rack and pinion gears at adjustment position **204** for allowing adjustments to be made in directions indicated by arrow E; and rotational gearing at adjustment position **206** for allowing adjustments to be made in directions indicated by arrow F. The adjustable elements used to provide for adjustments in directions indicated by arrows C, D, E, and F can be selected from among a variety of known adjustment systems.

[0042] As described in greater detail below, a technician can lock the first joint **122** in a locked state where the driven element **128** is not free to move relative to other portions of the joint or fixator assembly **200**. The technician can unlock the first joint **122** or otherwise place the first joint into an unlocked state for acute adjustments of the fixator assembly. In some embodiments, the first joint **122** can also be placed into a gradual-adjustment state for finer, more controlled movement and correction over time. The joint **122** can be manipulated either by hand or by a wrench on either one or multiple faces of the joint housing. Combining the two joint **122** with a strut body such as the center portion **126** and the second joint **124** can effectively allow for movement of two bone segments, fixator base elements, or other elements through six degrees of freedom.

[0043] The joint used as the first joint **122**, and also as the second joint **124** in some embodiments, can be selected from the various embodiments of multiple-axis joints described in the present disclosure. Embodiments of the joint **122** can include a captured joint that can be driven in two degrees of freedom in order to achieve angulations and/or rotations about a single point in space. Embodiments can include a ball, which can be an at least partially spherically-shaped element, which may be hollow or solid, and which may have flat regions, projections, depressions, elements that extend therefrom and/or regions that are threaded, slotted, and/or other-

wise provided with asperities. Embodiments of the joint **122** can include such a ball or nested ball/cylinder assembly that is securely captured in a housing such that a driven element can be oriented within a conical envelope protruding outward from the center of rotation. The ball or ball/cylinder assembly can be directly acted on by a driving mechanism (various exemplary forms detailed herein) that can be either automated or manually operated in order to achieve rotation and/or angulation of the ball itself. This joint can be used as part of an external fixator in order to move a fixator base element, bone segment, or other attachment through these degrees of freedom accurately.

[0044] Thus, the fixator assembly **200** constitutes an example of a single strut that can be used in a monolateral configuration with attachments connected to each end thereof that could connect to a fixation element, such as a half-pin. First, fixation elements are inserted and attached to bone segments. Second, the fixator assembly **200** is unlocked and each end can include a driven element **128** that is attached to the appropriate fixation element and acute adjustment would be made, if necessary. Third, the fixator assembly **200** would be locked to hold the bone segments in place. Next, gradual adjustments could be made over time by unlocking the assembly **200**, adjusting the driven elements **128**, and then once again locking the assembly **200**. This gradual adjustment over time could move two bone segments relative to each other in all six degrees of freedom.

[0045] FIGS. 3A through 3D show a first embodiment of a multiple-axis joint, generally designated as multiple-axis joint **300**. FIG. 3A shows a perspective view of the joint **300**. The joint **300** includes a ball joint **302** captured within a housing **304**. The ball joint **302** includes a ball **306**, which serves as an example of a spherically-shaped element. FIG. 3B shows a cross-sectional view of the ball **306** taken along section lines 3B-3B shown in FIG. 3A. FIG. 3C shows a cross-sectional view of the ball **306** taken along section lines 3C-3C shown in FIG. 3B. FIG. 3D shows a top view of the ball **306**, illustrating the axes of rotation.

[0046] The ball **306** includes two sets of gear teeth **308** and **310**. The gear teeth **308** and **310** are cut into the ball **306**, for example in a radial or circumferential configuration, and extend in respective directions that are 90 degrees from one another. A first gear **312** is mated with the first set of gear teeth **308**. A second gear **314** is mated with the second set of gear teeth **310**. A driven element **316** is rigidly attached to the ball **306** and extends out of the housing **304** through a slot **318**. Rotation of the first gear **312** will rotate the ball **306** within the housing **304**. Rotation of the second gear **314** will angulate the ball **306** within the housing **304**.

[0047] Depending on the embodiment, the first and second gears **312** and **314** can be rotated, directly or indirectly, by the technician in order to adjust the position of the driven element **316**. In some embodiments, the gears **312** and **314** can be connected, directly or indirectly, to respective knobs, handles, or the like that can be used by the technician for adjusting the position of the driven element **316**. In some embodiments, the gears **312** and **314** can be configured to be drivable, directly or indirectly, by a removable tool such as a hex key, screwdriver, or other tool that a technician can use in order to adjust the position of the driven element **316**. For example, each of the gears **312** and **314** can include a slot or the like, and the housing **300** can include an access hole through which a tool can be inserted and mated with the gears **312** and **314** so that the technician can rotate the gears **312** and **314**, and thereby

adjust the position of the driven element **316**. In some embodiments, each of the gears **312** and **314** can be attached to a respective drive shaft that extends from the gear **312**, **314** and can be rotated either directly or using a removable tool such that rotation of the drive shafts adjusts the position of the driven element **316**. Still further embodiments can include any desired configuration for allowing a technician to perform an action that causes rotation of selected gears **312** and **314** so that the technician can adjust the position of the driven element **316**.

[0048] The first gear **312** can be rotated for driving the ball **306** such that the driven element **316** is rotationally articulated about a first axis of rotation **320** in directions indicated by arrows **322**. As the first gear **312** is rotated, the ball **306** rotates and the gear teeth **310** slide within the gear teeth of the second gear **314**, thereby allowing rotation of the driven element **316** independently of angulation of the driven element **316**. The second gear **314** can be rotated for rotating the ball **306** about a second axis of rotation **326** such that the driven element **316** is angularly articulated, angulating the first axis of rotation **320**, thereby moving the driven element in directions indicated by arrows **324**. As the second gear **314** is rotated, the ball **306** rotates and the gear teeth **308** slide within the gear teeth of the first gear **312**, thereby allowing angulation of the driven element **316** independently of rotation of the driven element **316**. As shown in FIG. 3D, the first and second axes **320** and **326** extend through the center of the ball **306**. The first axis of rotation **320** extends through the center of the ball **306** in a direction that is at least substantially perpendicular to the second axis of rotation **326**. The first and second axes of rotation **320** and **326** intersect at a common rotation point about which the driven element **316** can be driven in two directions or degrees of freedom. The common rotation point is preferably at, or substantially near, the center of the ball **306**, thus allowing the driven element **316** to be intuitively adjusted in two degrees of freedom that intersect at a common point of rotation that is at or substantially near the center of the ball **306**. Note that the first set of gear teeth **308** on top of ball **306** are not shown in FIG. 3D so that the first and second axes of rotation **320** and **326** can be more clearly shown.

[0049] In some embodiments, the gears **312** and **314** can be repositioned relative to the ball **306** so as to be in contact with the ball **306** in a first position as shown in FIG. 3A, and to be out of contact with the ball **306** in a second position. For example, in some embodiments, the gears **312** and **314** can be slid or otherwise moved in and out of contact with the ball **306**. When the gears **312** and **314** are in contact with the ball **306**, the gears **312** and **314** act as a break to prevent movement of the ball **306** unless one or both of the gears **312** and **314** are rotating to drive the ball **306**. Thus, when the gears **312** and **314** are in contact with the ball **306**, the gears **312** and **314** act to effectively lock the joint **300**. However, once the gears **312** and **314** are moved out of contact with the ball **306** such that the first gear **312** is no longer mated with the first set of gear teeth **308** and the second gear **314** is no longer mated with the second set of gear teeth **310**, the ball **306** can freely move, thus allowing for acute adjustments of the position of the driven element **316**.

[0050] FIGS. 4A and 4B show a second embodiment of a multiple-axis joint, generally designated as multiple-axis joint **400**. FIG. 4A shows a perspective view of the joint **400**. The joint **400** can be similar to joint **300**, but includes a self-finding arm mechanism **402** in place of one of the gears and sets of gear teeth of joint **300**. In alternative embodi-

ments, the self-finding arm mechanism **402** can be in addition to the use the gears and sets of gear teeth of joint **300** discussed above.

[0051] The joint **400** can include a housing, such as housing **304**; however, the housing is not shown in FIG. 4 for purposes of clarity. The joint **400** includes a ball joint **402**. The ball joint **402** includes a ball **406**, which serves as an example of a spherically-shaped element. The ball **406** includes a set of gear teeth **410**. The gear teeth **410** are cut into the ball **406**, for example in a radial or circumferential configuration. A gear **414** is mated with the set of gear teeth **410**.

[0052] The joint **400** incorporates the usage of the gear **414** to angulate the ball **406** and the arm mechanism **402** to rotate the ball **406**. The arm mechanism **402** includes an arm **420** that acts within a slot **422** in the top of the ball **406**. FIG. 4B shows a partially-sectioned view illustrating a view of the arm **420** within the slot **422**. Rotation of the arm **420** rotates the ball about the first axis of rotation **320** as shown in FIG. 3D, whereas the gear **414** rotates the ball about the second axis of rotation **326** as shown in FIG. 3D. The arm **420** includes a first arm section **420a** and a second arm section **420b** connected by a joint **424**. The joint **424** can incorporate a universal joint, a ball and socket, or other mechanism to allow for the arm **420** to rotate the ball **406** about the first axis of rotation **320**. A driven element **426** is rigidly attached to the ball **406** and extends out of the housing (not shown).

[0053] Thus, the ball **406** can include the same first and second axes of rotation **320** and **326** as shown in FIG. 3D in connection with ball **306**. When the arm **420** is rotated, the gear teeth **410** in the bottom of the ball **406** can slide within the gear **414**, allowing rotation of the ball **406** about the first axis of rotation **320** independently of angulation of the driven element **406**. When the gear **414** is rotated, the joint **424** in the arm mechanism **402** can pivot as the ball **406** is rotated about the second axis of rotation **326**, allowing angulation of the driven element **406** independently of rotation of the driven element **406**.

[0054] In some embodiments, the gear **414** and arm mechanism **402** can be repositioned relative to the ball **406** so as to be in contact with the ball **406** in a first position as shown in FIG. 4, and to be out of contact with the ball **406** in a second position. For example, in some embodiments, the gear **414** and arm mechanism **402** can be moved in and out of contact with the ball **406**. When the gear **414** and arm mechanism **402** are in contact with the ball **406**, the gear **414** and arm mechanism **402** act as a break to prevent movement of the ball **406** unless one or both of the gear **414** and arm mechanism **402** are driving rotation of the ball **306**. Thus, when the gear **414** and arm mechanism **402** are in contact with the ball **406**, the gear **414** and arm mechanism **402** act to effectively lock the joint **400**. However, once the gear **414** and arm mechanism **402** are moved out of contact with the ball **406** such that the arm mechanism **402** is no longer mated with the slot **422** and the gear **414** is no longer mated with the set of gear teeth **410**, the ball **406** can freely move, thus allowing for acute adjustments of the position of the driven element **406**.

[0055] FIGS. 5A through 5C show a third embodiment of a multiple-axis joint, generally designated as multiple-axis joint **500**. FIG. 5A shows a perspective view of the joint **500**. The joint **500** can be similar to joint **300**, but incorporates an internal joint **502** placed at the center of a ball joint **506** to perform rotation in place of one of the gears and sets of gear

teeth of joint 300. FIG. 5B shows a view of the internal joint 502, and FIG. 5C shows a partially-sectioned view of the internal joint 502.

[0056] The joint 500 includes a housing 504, and a ball joint 506 captured within the housing 504. The ball joint 506 includes a ball 508, which serves as an example of a spherically-shaped element. The ball 508 includes a set of gear teeth 510. The gear teeth 510 are cut into the ball 508, for example in a radial or circumferential configuration. A gear 514 is mated with the set of gear teeth 510. The joint 500 incorporates the use of the gear 514 to angulate the ball 508 and the internal joint 502 to rotate the ball 508.

[0057] The internal joint 502 can be controlled by a control arm 520 that connects to a universal joint, a ball and socket joint, a torque shaft/wire, or other mechanism suitable for rotating the driven element 526. For example, as shown in FIGS. 5B and 5C, the internal joint 502 can include an inner ball 530 and an outer ball 532, which serve as examples of spherically-shaped elements. Note that the ball 508 is not shown in FIG. 5C so that the internal joint 502 can be more clearly shown. The outer ball 532 is rigidly connected to the control arm 520, and the inner ball 530 is rigidly connected to the driven element 526. The outer ball 532 includes a pin 534 that extends through the inner ball 530. The pin 534 acts on the inner ball 532 such that the inner ball 532 rotates about the longitudinal axis of the driven element 526, corresponding to the first axis 320 shown in FIG. 3D, when the control arm 520 is rotated. In some embodiments, the inner ball 532 can be fixed relative to the ball 508 such that the ball 508 also rotates as the control arm 520, inner ball 530, and driven element 526 are rotated. In such embodiments, the driven element 526 can be attached to the ball 508 instead of to the inner ball 530 as shown in FIG. 5C, and the inner ball 530 can be fixed to the ball 508. In other embodiments, the inner ball 530 and driven element 526 can be free to rotate relative to the ball 508. In such embodiments, the driven element 526 can be fixed to the inner ball 530 as shown in FIG. 5C and pass through a hole through the ball 508.

[0058] The ball 506 can include the same first and second axes of rotation 320 and 326 as shown in FIG. 3D in connection with ball 306. When the control arm 520 is rotated, the gear teeth 510 in the bottom of the ball 506 can slide within the teeth of gear 514, allowing rotation of the ball 508 about the first axis of rotation 320 independently of angulation of the driven element 526. When the gear 514 is rotated, the gear 514 drives the ball 506 to rotate about the second axis of rotation 326, allowing angulation of the driven element 526 independently of rotation of the driven element 526. When the gear 514 is rotated, the internal joint 502 can pivot about pin 534, allowing angulation independently of rotation.

[0059] FIGS. 6A, 6B, and 7 show a fourth embodiment of a multiple-axis joint, generally designated as multiple-axis joint 600. FIG. 6A shows a perspective view of the joint 600. The joint 600 incorporates a ball joint 602 that includes an outer ball 604 and a driven element 606. Outer ball 604 serves as an example of a spherically-shaped element. FIG. 6B shows a top view of the outer ball 604, illustrating the axes of rotation 620 and 626 about which joint 600 can drive the driven element 606. The driven element 606 extends in a more generally vertical direction compared to the driven elements 316, 426, and 526 of the first through third embodiment joints 300, 400, and 500, respectively, which extend in a generally horizontal direction in a manner similar to the driven element 128 used with fixators 100 and 200 shown in FIGS. 1 and 2,

respectively. This generally vertical orientation provides increased strength in tension and compression as compared to the more horizontal arrangement of the first through third embodiment joints 300, 400, and 500.

[0060] In the fourth embodiment, rotation of the ball joint 602 causes angulations of the driven element 606 in two degrees of freedom. Thus, unlike the first through third embodiments that include a first axis of rotation 320 that is coaxial with the driven element, the fourth embodiment joint 600 includes first and second axes of rotation 620 and 626 that are perpendicular to each other and to the longitudinal axis of the driven element 612. The first and second axes of rotation 620 and 626 intersect at a common rotation point about which the driven element 606 can be driven in two directions or degrees of freedom. The common rotation point is preferably at, or substantially near, the center of the outer ball 604, thus allowing the driven element 606 to be intuitively adjusted in two degrees of freedom that intersect at a common point of rotation that is preferably at or substantially near the center of the outer ball 604.

[0061] The ball joint 602 is captured within a housing 608. FIG. 7 shows the ball joint 602 without the housing 608 and other elements of the joint 600, and also shows portions of the ball joint 602 located within the outer ball 604. The ball joint 602 includes an inner ball 610 disposed concentrically within, and free to move relative to, the outer ball 604. The inner ball 610 serves as an example of a spherically-shaped element. The outer ball 604 can be driven to rotate in order to angulate the driven element 606 about the first rotational axis 620, while the inner ball 610 can be driven to rotate independently of the outer ball 604 for angulating the driven element 606 about the second rotational axis 626.

[0062] A first drive arm 612 is attached to the inner ball 610 such that the inner ball 610 rotates as the first drive arm 612 rotates about the longitudinal axis of the first drive arm 612, which corresponds to the second rotational axis 626. The driven element 606 is attached to the inner ball 610 and extends through the outer ball 604 through a slot 604a in the outer ball 604. The slot 604a defines a range of motion of the driven element 606 when driven by the first drive arm 612. The first drive arm 612 is pivotally attached to the inner ball 610, such that the first drive arm 612 is free to pivot relative to the inner ball 610 as indicated by arrow 614. As shown in FIG. 6, the first drive arm 612 can be driven by a first gear assembly 616. In alternative embodiments, the first gear assembly 616 can be replaced by a belt drive, a chain and sprocket drive, a torque shaft, a cable drive, or other such mechanisms.

[0063] A second drive arm 620 is rigidly attached to the outer ball 604 such that the outer ball 604 rotates as the second drive arm 620 rotates about the longitudinal axis of the second drive arm 612, which corresponds to the first rotational axis 620. The outer ball 604 can be driven by a second gear assembly 618. As shown in FIG. 6, the second drive arm 620 can be driven by a second gear assembly 616. In alternative embodiments, the second gear assembly 618 can be replaced by a belt drive, a chain and sprocket drive, a torque shaft, a cable drive, or other such mechanisms.

[0064] FIGS. 8 and 9 show a fifth embodiment of a multiple-axis joint, generally designated as multiple-axis joint 700. FIG. 8 shows a perspective view of the joint 700. The joint 700 includes a cylinder 702 captured within a housing 704. FIG. 9 shows a partially sectioned view of the cylinder 702, illustrating a ball joint 706 disposed within the cylinder 702.

[0065] The ball joint 706 includes a ball 708, which serves as an example of a spherically-shaped element, rigidly attached to a driven element 710. The joint 700 incorporates the ball joint 706 such that the driven element 710 extends in a generally vertical direction, similar to the fourth embodiment joint 600. The ball joint 706 also includes a first drive arm 712. The first drive arm 712 is attached to the ball 708 such that the ball 708 rotates as the first drive arm 712 rotates about the longitudinal axis of the first drive arm 712. The first drive arm 712 is pivotally attached to the ball 708, such that the first drive arm 712 is free to pivot relative to the ball 708 as indicated by arrow 714. The driven element 710 is attached to the ball 708 and extends through the cylinder 702 through a slot 702a in the cylinder 702. The slot 702a defines a range of motion of the driven element 710 when driven by the first drive arm 712.

[0066] The rotational axis of joint 700 are like those of the fourth embodiment joint 600 shown in FIG. 6B. Thus, the joint 700 includes first and second axes of rotation 620 and 626 that are perpendicular to each other and to the longitudinal axis of the driven element 710. The first and second axes of rotation 620 and 626 intersect at, or substantially near, the center of the cylinder 702, thus allowing the driven element 710 to be intuitively adjusted in two degrees of freedom that intersect at or substantially near the center of the cylinder 702. The ball 708 is disposed within, and free to move relative to, the cylinder 702. The cylinder 702 can be driven to rotate in order to angulate the driven element 710 about the first axis of rotation 620, while the ball 708 can be driven to rotate independently of the cylinder 702 for angulating the driven element 710 about the second axis of rotation 626.

[0067] The first drive arm 712 is rigidly attached to the ball 708 and can be driven by a first gear assembly 716. The first gear assembly 716 includes a first gear 718 that is rigidly attached to the first drive arm 712 such that the first drive arm 712 rotates with the first gear 718. The first gear assembly 716 also includes a first rack member 720. The first rack member 720 is a cylindrically cut rack having at least one threaded end 722. In addition, or alternatively, the first rack member 720 can have a second threaded end (not shown). The threaded end 722 mates with similar threads within the housing 704 such that rotation of the first rack member 720 about its longitudinal axis causes the first rack member 720 to move translationally along its longitudinal axis. The first rack member 720 can travel translationally and be rotated at the same time, allowing gear teeth of the first gear 718 to slide along the cylindrical cuts of the first rack member 720 as the first rack member 720 travels, thereby causing the first gear 718 to rotate. Rotation of the first gear 718 rotates the first drive arm 712, which in turn rotates the ball 708, which results in angulation of the driven element 710 about the second axis of rotation 626. In alternative embodiments, the first gear assembly 716 can be replaced by a belt drive, a chain and sprocket drive, a torque shaft, a cable drive, or other such mechanisms. When the first rack member 720 is not being rotated, the threaded end 722 acts as a braking/holding mechanism with the threads providing the braking force in the direction parallel to the longitudinal axis of the first rack member 720. Thus, when the first rack member 720 is not being rotated, the first rack member 720 acts to lock the first gear 718 so that the first gear 718 cannot rotate, thereby preventing the ball 708 from angulating the driven element 710. In alternative embodiments, the rack member 720 can be cut at an angle rather than cut cylindrically, for example the rack member

720 can be a worm or include a worm portion, and in such embodiments the gear 718 can be a worm gear.

[0068] A second drive arm 732 is rigidly attached to the cylinder 702 can be driven by a second gear assembly 736. The second gear assembly 736 includes a second gear 738 that is rigidly attached to the second drive arm 732 such that the second drive arm 732 rotates with the second gear 738. The second gear assembly 736 also includes a second rack member 740. The second rack member 740 is a cylindrically cut rack having at least one threaded end 742. In addition, or alternatively, the second rack member 740 can have a second threaded end 744. The threaded end 742 and/or 744 mates with similar threads within the housing 704 such that rotation of the second rack member 740 about its longitudinal axis causes the second rack member 740 to move translationally along its longitudinal axis. The second rack member 740 can travel translationally and be rotated at the same time, allowing gear teeth of the second gear 738 to slide along the cylindrical cuts of the second rack member 740 as the second rack member 740 travels, thereby causing the second gear 738 to rotate. Rotation of the second gear 738 rotates the second drive arm 732, which in turn rotates the cylinder 702, which results in angulation of the driven element 710 about the first axis of rotation 620. In alternative embodiments, the second gear assembly 736 can be replaced by a belt drive, a chain and sprocket drive, a torque shaft, a cable drive, or other such mechanisms. When the second rack member 740 is not being rotated, the threaded end 742 acts as a braking/holding mechanism with the threads providing the braking force in the direction parallel to the longitudinal axis of the second rack member 740. Thus, when the second rack member 740 is not being rotated, the second rack member 740 acts to lock the second gear 738 so that the second gear 738 cannot rotate, thereby preventing the cylinder 702 from angulating the driven element 710. In alternative embodiments, the rack member 740 can be cut at an angle rather than cut cylindrically, for example the rack member 740 can be a worm or include a worm portion, and in such embodiments the gear 738 can be a worm gear.

[0069] FIGS. 10A and 10B show a sixth embodiment of a multiple-axis joint, generally designated as multiple-axis joint 800. FIG. 10A shows a perspective view of the joint 800. The joint 800 can be substantially the same as joint 700, except for differences in the gear assemblies discussed below. The joint 800 includes a housing 704 as shown in FIG. 8. The joint 800 also includes a cylinder 702 and a ball joint 706 as shown in FIG. 9 and described in connection with joint 700. Elements of the joint 800 that can be the same or substantially the same as corresponding elements of joint 700 have retained the same element numbers, and the description of those like-numbered elements in connection with joint 700 applies equally to joint 800.

[0070] The joint 800 includes a first drive arm 712 rigidly attached to the ball 708 and a second drive arm 732 rigidly attached to the cylinder 702 as shown in FIGS. 8 and 9. A first gear assembly 802 includes a first gear 718 that is rigidly attached to the first drive arm 712. A second gear assembly 804 and a second gear 738 is rigidly attached to the second drive arm 732. The first and second gears 718 and 738 can angulate the driven element 710 as described above in connection with joint 700 about first and second rotational axes 620 and 626.

[0071] FIG. 10B shows an enlarged block diagram of the second gear assembly 804, as well as a portion of first gear

assembly **802**. The first and second gear assemblies **802** and **804** both allow for acute and finer or more gradual adjustments. The first and second gear assemblies **802** and **804** can be substantially the same; thus, the following description of the second gear assembly **804** applies equally to the first gear assembly **802**.

[0072] The second gear assembly **804** includes a rack member **806** supported by a lead screw **808**. The lead screw **808** can be rotated for fine/gradual adjustment of the driven element **710**. Rotation of the lead screw **808** as indicated by arrow **810** causes the rack member **806** to translate along the lead screw **808** as indicated by arrow **812**. The direction in which the rack member **806** travels relative to the rotation direction of the lead screw **808** will depend on the selected threading direction of the lead screw **808**, which can vary for different embodiments. As the rack member **806** travels translationally along the lead screw **808**, the rack member **806** engages with gear teeth of the second gear **738** causing the second gear **738** to rotate as indicated by arrow **814**.

[0073] The second gear assembly **804** also includes a first acute adjustment block **816**. The block **816** is part of an acute adjustment assembly **818** that also includes an acute adjustment block **820** of the first gear assembly **802**. The acute adjustment assembly **818** includes a lock member **822**. As shown in FIG. 10A, the adjustment blocks **816** and **820** include teeth that can mate with teeth of the lock member **822**. As indicated in FIG. 10B, the lock member **822** can be pulled away from the adjustment blocks **816** and **820** in order to unlock the acute adjustment assembly **818**. The lock member **822** can be pushed against the adjustment blocks **816** and **820** (position shown in FIG. 10A) in order to lock the acute adjustment assembly **818**. Thus, the lock member **822** can be pulled away from the adjustment blocks **816** and **820** in order to unlock the acute adjustment assembly **818** and make acute adjustments to the driven element **710**. While the lock member **822** is pulled away from the adjustment blocks **816** and **820**, the adjustment blocks **816** and **820** can travel translationally, and independently of each other, in the directions indicated by arrows **824** and **826**. The lead screw **808** is fixed relative to the adjustment block **816** such that the lead screw **808** translates with the adjustment block **816**. The threads of the lead screw **808** carry the rack member **806** such that, if the lead screw is not rotating, the rack member **806** translates in directions **812** with the lead screw **808** and the adjustment block **816**. As the rack member **806** travels translationally with the lead screw **808** and adjustment block **816**, the rack member **806** engages with gear teeth of the second gear **738** causing the second gear **738** to rotate as indicated by arrow **814**. This allows for a more acute adjustment of the driven element **710** about the first rotational axis **620** as compared to more gradual adjustments that can be made as described above by rotating the lead screw **810**.

[0074] As mentioned above, the first gear assembly **802** can be identical or substantially the same as the second gear assembly **804**. Thus, the driven element **710** can be acutely and gradually adjusted about the second rotational axis **626** via the first gear **718**, first drive arm **712**, and ball joint **706** using the first gear assembly **802** and acute adjustment assembly **818** in the same manner as describe above in connection with the second gear assembly **804**.

[0075] The locking member **822** simultaneously engages and locks both of the adjustment blocks **816** and **820** when pushed in (direction into the page as indicated by direction **830** in FIG. 10B), and simultaneously disengages and

unlocks both of the adjustment blocks **816** and **820** when pulled out (direction into the page as indicated by direction **832** in FIG. 10B). Thus, when the locking member **822** is moved to the unlocking position, the driven element **710** can be acutely adjusted along both the first and second rotational axes **620** and **626**. In alternative embodiments, separate locking members **822** can be provided for each of the adjustment blocks **816** and **820**. Such an embodiment allows for acute adjustment of only one of the rotational axes **620** and **626** at a time by unlocking only a selected one of the two locking members **822**, or simultaneous acute adjustments by unlocking both of the locking members **822**.

[0076] FIG. 11 shows an alternative second gear assembly **804a** that can be used with the joint **800**. The first gear assembly **802** can be similarly modified. The gear assembly **804a** also allows for acute and finer or more gradual adjustments.

[0077] The second gear assembly **804a** includes the rack member **806** supported by an alternative lead screw **808a**. The lead screw **808a** includes a helically threaded portion **850** that supports the rack member **806**. The lead screw **808a** also includes a cylindrically cut portion **852**. The lead screw **808a** can be rotated for fine/gradual adjustment of the driven element **710**. Rotation of the lead screw **808a** as indicated by arrow **810** in FIG. 10B causes the rack member **806** to translate along the lead screw **808a** as indicated by arrow **812** in FIG. 10B. The direction in which the rack member **806** travels relative to the rotation direction of the lead screw **808a** will depend on the selected threading direction of the threaded portion **850** of the lead screw **808a**, which can vary for different embodiments. As the rack member **806** travels translationally along the lead screw **808a**, the rack member **806** engages with gear teeth of the second gear **738** causing the second gear **738** to rotate as indicated by arrow **814** in FIG. 10B.

[0078] The second gear assembly **804a** also includes an alternative acute adjustment assembly **818a** that includes a lock member **854** and the cylindrically cut portion **852** of the lead screw **808a**. The lock member **854** can be controlled to engage or disengage the cylindrical cuts of the cylindrically cut portion **852** of the lead screw **808a**. The lock member **854** includes teeth that can mate with the cylindrically cuts of the cylindrically cut portion **852** of the lead screw **808a**. The lock member **854** can be pulled away from the cylindrically cut portion **852** of the lead screw **808a** in order to unlock the acute adjustment assembly **818a** and thereby allow for acute adjustments of the second gear assembly **804a**. The lock member **854** can be moved to engage the cylindrically cut portion **852** of the lead screw **808a** (position shown in FIG. 11) in order to lock the acute adjustment assembly **818a**. Thus, the lock member **854** can be pulled away from the cylindrically cut portion **852** of the lead screw **808a** in order to unlock the acute adjustment assembly **818a** and make acute adjustments to the driven element **710**. While the lock member **854** is pulled away from the cylindrically cut portion **852** of the lead screw **808a**, the lead screw **808a** can travel translationally in the directions indicated by arrow **856**. The threaded portion **850** of the lead screw **808a** carry the rack member **806** such that, if the lead screw **808a** is not rotating, the rack member **806** translates in directions **856** with the lead screw **808a**. As the rack member **806** travels translationally with the lead screw **808a**, the rack member **806** engages with gear teeth of the second gear **738** causing the second gear **738** to rotate as indicated by arrow **814** in FIG. 10B. This allows for a more

acute adjustment of the driven element **710** about the first rotational axis **620** as compared to more gradual adjustments that can be made as described above by rotating the lead screw **810**.

[0079] As mentioned above, an alternative first gear assembly **802** can be identical or substantially the same as the alternative second gear assembly **804a**. Thus, the driven element **710** can be acutely and gradually adjusted about the second rotational axis **626** via the first gear **718**, first drive arm **712**, and ball joint **706** using the first gear assembly **802** and acute adjustment assembly **818a** in the same manner as describe above in connection with the second gear assembly **804a**.

[0080] Still further embodiments of multiple-axis joints include embodiments that combine various elements of the first through sixth embodiment joints **300**, **400**, **500**, **600**, **700**, and **800**. For example, the joints **300**, **400**, and **500** can be modified to include one or more gear assemblies, such as gear assemblies **616**, **618**, **716**, **736**, **802**, and **804**, and/or acute adjustment assemblies, such as acute adjustment assembly **818**. More specifically, any of the gear assemblies **616**, **618**, **716**, **736**, **802**, and **804** can be used to drive any of the gears **312**, **314**, **414**, and **514**. The gear assemblies **616**, **618**, **716**, **736**, **802**, and **804** constitute examples of drive systems that can be driven manually, by way of a handle, knob, removable tool, key, or any other implement suitable for allowing a person to make manual adjustments for driving the driven element (such as driven element **316**, **426**, **526**, **606**, or **710**) in a desired direction.

[0081] Any of the multiple-axis joints **300**, **400**, **500**, **600**, **700**, and **800** and variations thereof can be used as the first joint **122** and/or the second joint **124** of the fixator ring system **100** or the fixator assembly **200**. Still further embodiments of fixator ring systems that can include any of the multiple-axis joints described herein are described below in connection with FIGS. **12-14**.

[0082] FIG. **12** shows a perspective view of a first alternative embodiment of an external fixator ring system, generally designated as external fixator ring system **900**. The fixator ring system **900** includes a first fixator ring **902a** and a second fixator ring **902b**, which serve as examples of fixator base elements. The fixator rings **902a** and **902b** both include a plurality of strut mounting positions **904**. The fixator rings **902a** and **902b** are connected by a pair of connection struts **906** and **908**. In this embodiment, both of the struts **906** and **908** are active struts. While two active struts **906** and **908** are shown, alternative embodiments can include more or fewer active struts.

[0083] The first fixator ring **902a** includes a top surface **912** and an opposing bottom surface (not shown). The top surface **912** includes numerous holes **916** that extend through the top surface **912** to the bottom surface (not shown). The holes **916** may be used for attachment of wire and half pin fixation elements (bolts), threaded or telescopic connection rods, plates, posts or other device connection elements to the first fixator ring **902a**. The outer side surface **920** of the first fixator ring **902a** can include numerous threaded apertures (not shown) that provide additional attachment points for struts or other connection elements (not shown). The second fixator ring **902b** can be identical or similar to the first fixator ring **902a**.

[0084] Although the shape of the fixator rings **902a** and **902b** as shown FIG. **12** is substantially circular, the shape of the fixator rings **902a** and **902b** can vary to accommodate the

physical contour of various body parts to which the fixation system **900** would be attached. For example, the fixator rings **902a** and **902b** can be fixator base elements configured to have an oval shape, D-shape, U-shape, C-shape, a polygon, or other irregular shapes. In some exemplary embodiments, an elliptical fixator ring (not shown) may be particularly advantageous. The insertion of pins or wires into a patient's limb can cause the surrounding tissue to swell unevenly, and in such a case, an elliptical fixator ring can accommodate the uneven swelling better than a circular ring can. The fixator rings **902a** and **902b** may be fixator base elements that form a complete ring (full ring) or a segment or portion of a ring (e.g., half ring, $\frac{1}{3}$ ring, $\frac{1}{4}$ ring, $\frac{3}{8}$ ring, $\frac{3}{8}$ ring, $\frac{2}{3}$ ring, $\frac{3}{4}$ ring, and other) that is either used alone or joined with other segments or portions of the ring to form a fixator ring (not shown). The fixator rings **902a** and **902b** may be fixator base elements constructed of any material that provides the structural rigidity necessary for fixation such as metal, alloy, carbon fiber, plastic, ceramic and so forth.

[0085] The strut **906** includes a first joint **922** and a second joint **924** connected by a center portion **926**. The first joint **922** and second joint **924** are embodiments of multiple axis joints, such as the fourth, fifth, or sixth embodiment joints **600**, **700**, and **800**, that include a generally vertical driven element. The first joint **922** includes a first driven element **928** that connects to one of the strut mounting positions **904** of the first fixator ring **902a**. As discussed herein, the driven element **928** can be angularly and/or rotationally repositioned relative to the center portion **926** of the strut **906**. The second joint **924** includes a second driven element **930** that connects to one of the strut mounting positions **904** of the second fixator ring **902b**. As discussed herein, the driven element **930** can be angularly and/or rotationally repositioned relative to the center portion **926** of the strut **906**. The connection strut **908** also includes first and second joints **922** and **924** and can be identical to the first connection strut **906**.

[0086] The joints **922** and **924** of the struts **906** and **908** can be manipulated, for example by hand or using a tool such as a wrench, to angulate and/or rotate (depending on the joint) the driven elements **928** and **930**. For example, the joints **922** and **924** can include set screws or the like on the housings thereof for allowing insertion of a wrench, screwdriver, or other such tool so that the user can drive the gears/gear assemblies (such as gears **312**, **314**, **414**, and **514** and/or gear assemblies **616**, **618**, **716**, **736**, **802**, and **804**) and thereby reposition the driven elements **928** and **930**.

[0087] The center portion **926** can be a strut body such as center portion **126** of the fixator assembly **200** shown in FIG. **2**, which includes various adjustable elements in order to allow for six degrees of freedom. Combining two of the multiple-axis joints described herein with such a strut body can allow for effectively moving two bone segments, fixator base elements, or other elements through all six degrees of freedom.

[0088] Two struts such as struts **906** and **908** can thus be used with rings **902a** and **902b** in order to move two bone segments relative to one another. First, the rings **902a** would be attached to bone segments with fixation elements such as half pins or k-wires. Second, the struts **906** and **908** would be unlocked and attached to the rings **902a** and **902b** with an angular separation preferably of greater than 90 degrees and an acute adjustment would be made, if necessary. Third, the struts **906** and **908** would be locked into an active-locked state so as to hold the bone segments in place. Next, gradual adjust-

ment could be made over time by adjusting the driven elements **928** and **930** of the struts **906** and **908** while the struts **906** and **908** are in active-locked states. This gradual adjustment over time could move two bone segments relative to each other in all six degrees of freedom.

[0089] FIG. 13 shows a perspective view of a second alternative embodiment of an external fixator ring system, generally designated as external fixator ring system **1100**. The fixator ring system **1100** includes a first fixator ring **1102a** and a second fixator ring **1102b**, which serve as examples of fixator base elements. The fixator rings **1102a** and **1102b** both include a plurality of strut mounting positions **1104**. The fixator rings **1102a** and **1102b** are connected by a pair of active struts **906** and **908**, which can be identical to the active struts **906** and **908** described above, wherein like elements of active struts **906** and **908** have retained like element numbers. The fixator rings **1102a** and **1102b** are also connected by a pair of passive struts **1130** and **1132**, which can be the same as, or similar to, passive struts **108** and **110**.

[0090] The first fixator ring **1102a** includes an outer side surface **1112a** and an opposing inner side surface **1112b**. Numerous holes **1116** that extend through the outer side surface **1112a** to the inner side surface **1112b**. The holes **1116** may be used for attachment of threaded or telescopic connection rods **1130** and **1132** between the first and second fixator rings **1102a** and **1102b**. The holes **1116** may also be used for attachment of wire and half pin fixation elements (bolts), additional threaded or telescopic connection rods, plates, posts or other device connection elements to the first fixator ring **1102a**. The second fixator ring **1102b** can be identical or similar to the first fixator ring **1102a**.

[0091] Although the shape of the fixator rings **1102a** and **1102b** as shown FIG. 13 is substantially circular, the shape of the fixator rings **1102a** and **1102b** can vary to accommodate the physical contour of various body parts to which the fixation system **1100** would be attached. For example, the fixator rings **1102a** and **1102b** can be fixator base elements configured to have an oval shape, D-shape, U-shape, C-shape, a polygon, or other irregular shapes. In some exemplary embodiments, an elliptical fixator ring (not shown) may be particularly advantageous. The insertion of pins or wires into a patient's limb can cause the surrounding tissue to swell unevenly, and in such a case, an elliptical fixator ring can accommodate the uneven swelling better than a circular ring can. The fixator rings **1102a** and **1102b** may be fixator base elements that form a complete ring (full ring) or a segment or portion of a ring (e.g., half ring, $\frac{1}{3}$ ring, $\frac{1}{4}$ ring, $\frac{3}{8}$ ring, $\frac{5}{8}$ ring, $\frac{2}{3}$ ring, $\frac{3}{4}$ ring, and other) that is either used alone or joined with other segments or portions of the ring to form a fixator ring (not shown). The fixator rings **1102a** and **1102b** may be fixator base elements constructed of any material that provides the structural rigidity necessary for fixation such as metal, alloy, carbon fiber, plastic, ceramic and so forth.

[0092] The strut **906** includes a first joint **922** and a second joint **924** connected by a center portion **926**. The first joint **922** and second joint **924** are embodiments of multiple axis joints, such as the fourth, fifth, or sixth embodiment joints **600**, **700**, and **800**, that include a generally vertical driven element. The first joint **922** includes a first driven element **928** that connects to one of the holes **916** of the first fixator ring **902a**. As discussed herein, the driven element **928** can be angularly and/or rotationally repositioned relative to the center portion **926** of the strut **906**. The second joint **924** includes a second driven element **930** that connects to one of the holes **916** of the

second fixator ring **902b**. As discussed herein, the driven element **930** can be angularly and/or rotationally repositioned relative to the center portion **926** of the strut **906**. The connection strut **908** also includes first and second joints **922** and **924** and can be identical to the first connection strut **906**.

[0093] The joints **922** and **924** of the struts **906** and **908** can be manipulated, for example by hand or using a tool such as a wrench, to angulate and/or rotate (depending on the joint) the driven elements **928** and **930**. For example, the joints **922** and **924** can include set screws or the like on the housings thereof for allowing insertion of a wrench, screwdriver, or other such tool so that the user can drive the gears/gear assemblies (such as gears **312**, **314**, **414**, and **514** and/or gear assemblies **616**, **618**, **716**, **736**, **802**, and **804**) and thereby reposition the driven elements **928** and **930**.

[0094] The center portion **926** can be a strut body such as center portion **126** of the fixator assembly **200** shown in FIG. 2, which includes various adjustable elements in order to allow for six degrees of freedom. Combining two of the multiple-axis joints described herein with such a strut body can allow for effectively moving two bone segments, fixator base elements, or other elements through all six degrees of freedom.

[0095] The two struts **906** and **908** can thus be used with a set of rings **1102a** and **1102b** in order to move two bone segments relative to one another. First, the rings **1102a** and **1102b** would be attached to the bone segments with fixation elements such as half pins or k-wires. Second, the two struts **906** and **908** would be unlocked and attached to the rings **1102a** and **1102b** with an angular separation preferably greater than 90 degrees and an acute adjustment would be made, if necessary. Third, the struts **906** and **908** would be locked to hold the bone segments in place. Fourth, the passive struts **1130** and **1132** would be attached between the two rings **1102a** and **1102b** for additional support against tissue and other forces. Next, gradual adjustments could be made by unlocking the passive struts **1130** and **1132**, adjusting the driven elements **928** and **930** of the active struts **906** and **908**, and then once again locking the passive struts **1130** and **1132**. This gradual adjustment over time could move two bone segments relative to each other in all six degrees of freedom. The passive struts **1130** and **1132** are removable such that during x-rays or other scenarios when increased access or visibility is necessary the passive struts **1130** and **1132** can be removed, and the active struts **906** and **908** are sufficient for rigidly maintaining the relative positions of the rings **1102a** and **1102b**.

[0096] FIGS. 14A through 14C show an embodiment of a passive support strut **1200** that can be used as passive struts **108** and **110** in FIG. 1, and passive struts **1132** and/or **1130** in FIG. 13. The passive support strut **1200** includes multiple joint members **1202** that are nested within one another, as shown in FIG. 14C, between a pair of attachment studs **1208a** and **1208b**. The attachment studs **1208a** and **1208b** can be used to attach the passive support strut **1200** to fixator base elements or other devices. For example, the attachment studs can be threaded studs that can pass through a hole in a fixator ring and secured in place using a threaded nut. Alternatively, the attachment studs can be configured pass through a hole in a fixator ring and secured in place using a cotter pin. Still further embodiments can use any desirable type of attachment configuration.

[0097] The joint members **1202** can rotate in all three orthogonal degrees of freedom relative to each other in order

to change length and direction and to follow fixator base elements as they are driven in all six degrees of freedom by one or more active struts. The passive support strut **1200** can be locked into a rigid state such that the rings **102a** and **102b** are fixed relative to each other, and unlocked into a free state such that acute adjustments can be made to the relative positions of the rings **102a** and **102b**. As shown in FIGS. **14B**, the attachment studs **1208a** and **1208b** are each connected to a central locking element **1206** by a connection element **1210** that passes through channels **1212** of the joint members **1202**. The connection element **1210** can be a cable, cord, string, wire, or the like. The central locking element **1206** is disposed within a central support member **1204**. Rotation of the central locking element **1206** can wind or unwind the connection element **1210**, thereby increasing or decreasing the compression on the joint members **1202** between the central support member **1204** and the attachment studs **1208a** and **1208b**. The locking element **1206** can be a spool, cam, or other suitable device. The joint members **1202** can be compressed together by operation of the locking element **1206** on the connection element **1210** such that friction between the joint elements **1202** prohibits relative movement between the joint elements **1202**. The passive stud **1200** can thus be locked. The passive stud **1200** can be unlocked by operating the locking element **1206** in order to reduce the compression between the attachment studs **1208a**, **1208b** and the central support member **1204**. In some embodiments, the central locking element **1206** can include slots, grooves, detents, or the like for preventing the central locking element **1206** from rotating due to the compressive forces of the connection element **1210** while the passive support strut **1200** is locked. In some embodiments, the central locking element **1206** can include a handle, lever, or other such element for allowing a technician to lock/unlock the passive support strut **1200**. In some embodiments, the central locking element **1210** can include a slot, key, or otherwise be configured to be operated by a removable tool.

[0098] FIG. **15** shows an alternative embodiment of a support strut **1300** that can be used in place of passive struts **108** and **110** in FIG. **1**, and passive struts **1132** and/or **1130** in FIG. **13**. The support strut **1300** includes first and second joints **1302a** and **1302b** attached to opposing ends of a central portion **1304**. In some embodiments, the central portion **1304** can be lengthwise adjustable. The first and second joints **1302a** and **1302b** can be attached to a hole in a fixator ring and secured in place using a threaded screw, bolt, combination of a nut and bolt, or any other desired attachment means. The first and second joints **1302a** and **1302b** can include any desired type of joint that allows for rotation in three degrees of freedom, including heim joints, universal joints, ball joints, or other joints.

[0099] All of the compositions and/or methods disclosed and claimed herein can be made and executed without undue experimentation in light of the present disclosure. While the compositions and methods of this invention have been described in terms of preferred embodiments, it will be apparent to those of skill in the art that variations may be applied to the compositions and/or methods and in the steps or in the sequence of steps of the method described herein without departing from the concept, spirit and scope of the invention. All such similar substitutes and modifications apparent to those skilled in the art are deemed to be within the spirit, scope and concept of the invention as defined by the appended claims.

What is claimed is:

1. A fixator system, comprising:
 - a first fixator base element;
 - a second fixator base element;
 - a first active strut connected between the first fixator base element and the second fixator base element; and
 - a first passive strut connected between the first fixator base element and the second fixator base element;
 wherein the first passive strut is configured to be placed into a passive locked state such that the first passive strut is non-adjustable and resists relative positional changes between the first and second fixator base elements, and placed into an unlocked state such that the first passive strut freely allows relative positional changes between the first and second fixator base elements;
 - wherein the first active strut is configured to be placed into an active locked state such that the first active strut resists relative positional changes between the first and second fixator base elements, and placed into an unlocked state such that the first active strut freely allows relative positional changes between the first and second fixator base elements;
 - wherein the first active strut is configured to allow relative positional changes between the first and second fixator base elements while maintaining rigidity while the first active strut is in the active locked state; and
 - wherein the first active strut is configured to allow adjustment of an overall length of the first active strut when the first active strut is in the active locked state.
2. The fixator system of claim 1, further comprising a second active strut connected between the first fixator base element and the second fixator base element;
 - wherein the second active strut is configured to be placed into an active locked state such that the second active strut resists relative positional changes between the first and second fixator base elements, and placed into an unlocked state such that the second active strut freely allows relative positional changes between the first and second fixator base elements;
 - wherein the second active strut is configured to allow relative positional changes between the first and second fixator base elements while maintaining rigidity while the second active strut is in the active locked state; and
 - wherein the second active strut is configured to allow adjustment of an overall length of the second active strut when the second active strut is in the active locked state.
3. The fixator system of claim 1, further comprising a second passive strut connected between the first fixator base element and the second fixator base element;
 - wherein the second passive strut is configured to be placed into a passive locked state such that the second passive strut is non-adjustable and resists relative positional changes between the first and second fixator base elements, and placed into an unlocked state such that the second passive strut freely allows relative positional changes between the first and second fixator base elements.
4. The fixator system of claim 1, wherein the first active strut includes a joint comprising a driven element attached to the first fixator base element, a first drive system that rotates the driven element about a first axis of rotation, and a second drive system that rotates the driven element about a second axis of rotation, wherein the first and second axes intersect at a common point of rotation of the driven element.

5. The fixator system of claim 1, wherein the first active strut is configured to be placed into a passive locked state such that the first active strut is non-adjustable and resists relative positional changes between the first and second fixator base elements.

6. A strut for a fixator system, the strut comprising:

a first joint;

a second joint; and

a central portion connected between the first and second joints, the central portion being adjustable in at least two degrees of freedom;

wherein the strut is configured to be placed into an active locked state such that the strut resists relative positional changes between the first and second joints, and placed into an unlocked state such that the strut freely allows relative positional changes between the first and second joints;

wherein the strut is configured to allow for relative positional changes between the first joint and the second joint while maintaining rigidity while the strut is in the active locked state; and

wherein the strut is configured to allow for adjustment of an overall length of the strut when the strut is in the active locked state.

7. The strut of claim 6, wherein the first joint further comprises:

a first drive system that rotates a first driven element of the first joint about a first axis of the first joint; and

a second drive system that rotates the first driven element about a second axis of the first joint;

wherein the first and second axes intersect about a first common point of rotation of the first driven element.

8. The strut of claim 6, wherein the central portion is lengthwise adjustable.

9. The strut of claim 6, wherein the strut is configured to be placed into a passive locked state such that the strut is non-adjustable and resists relative positional changes between the first and second joints.

10. A fixator system, comprising:

a first fixator base element;

a second fixator base element;

a first active strut connected between the first fixator base element and the second fixator base element; and

a first passive strut connected between the first fixator base element and the second fixator base element;

wherein the first passive strut is configured to be placed into a passive locked state such that the first passive strut is non-adjustable and resists relative positional changes between the first and second fixator base elements, and placed into an unlocked state such that the first passive strut freely allows relative positional changes between the first and second fixator base elements;

wherein the first active strut is configured to be placed into an active locked state such that the first active strut resists relative positional changes between the first and second fixator base elements,

placed into a passive locked state such that the first active strut is non-adjustable and resists relative positional changes between the first and second fixator base elements, and

placed into an unlocked state such that the first active strut freely allows relative positional changes between the first and second fixator base elements; and

wherein the first active strut is configured to allow relative positional changes between the first and second fixator

base elements while maintaining rigidity while the first active strut is in the active locked state.

11. The fixator system of claim 10, further comprising a second active strut connected between the first fixator base element and the second fixator base element;

wherein the second active strut is configured to be

placed into an active locked state such that the second active strut resists relative positional changes between the first and second fixator base elements,

placed into a passive locked state such that the second active strut is non-adjustable and resists relative positional changes between the first and second fixator base elements, and

placed into an unlocked state such that the second active strut freely allows relative positional changes between the first and second fixator base elements; and

wherein the second active strut is configured to allow relative positional changes between the first and second fixator base elements while maintaining rigidity while the second active strut is in the active locked state.

12. The fixator system of claim 10, further comprising a second passive strut connected between the first fixator base element and the second fixator base element;

wherein the second passive strut is configured to be placed into a passive locked state such that the second passive strut is non-adjustable and resists relative positional changes between the first and second fixator base elements, and placed into an unlocked state such that the second passive strut freely allows relative positional changes between the first and second fixator base elements.

13. The fixator system of claim 10, wherein the first active strut includes a joint comprising a driven element attached to the first fixator base element, a first drive system that rotates the driven element about a first axis of rotation, and a second drive system that rotates the driven element about a second axis of rotation, wherein the first and second axes intersect at a common point of rotation of the driven element.

14. The fixator system of claim 10, wherein the first active strut is configured to allow adjustment of an overall length of the first active strut when the first active strut is in the active locked state.

15. A strut for a fixator system, the strut comprising:

a first joint;

a second joint; and

a central portion connected between the first and second joints, the central portion being adjustable in at least two degrees of freedom;

wherein the strut is configured to be

placed into an active locked state such that the strut resists relative positional changes between the first and second joints,

placed into a passive locked state such that the strut is non-adjustable and resists relative positional changes between the first and second joints, and

placed into an unlocked state such that the strut freely allows relative positional changes between the first and second joints; and

wherein the strut is configured to allow for relative positional changes between the first joint and the second joint while maintaining rigidity while the strut is in the active locked state.

16. The strut of claim **15**, wherein the first joint further comprises:

a first drive system that rotates a first driven element of the first joint about a first axis of the first joint; and
a second drive system that rotates the first driven element about a second axis of the first joint;
wherein the first and second axes intersect about a first common point of rotation of the first driven element.

17. The strut of claim **15**, wherein the central portion is lengthwise adjustable.

18. The strut of claim **15**, wherein the strut is configured to allow for adjustment of an overall length of the strut when the strut is in the active locked state.

* * * * *